



भारत सरकार / Government of India
विद्युत मंत्रालय./ Ministry of Power
केंद्रीय विद्युत प्राधिकरण / Central Electricity Authority
प्रणाली योजना एवं परियोजना मूल्यांकन विभाग /
System Planning & Project Appraisal Division
सेवा भवन, आर के पुरम / Sewa Bhawan, R.K. Puram
नई दिल्ली / New Delhi – 110 066
वेबसाइट / Website : www.cea.nic.in



[ISO : 9001 : 2008]

No.200/10/2012-SP&PA/ 1667-1531

Dated : 19th December 2012

To

As per list attached

Sub : Combined meeting of Standing Committee on Power System Planning –
uploading of Report on Static VAR Compensators (SVC) requirement

Sir,

In continuation to our earlier letter of even no. dated 11.12.2012, where it was mentioned that the meeting schedule was revised to give constituents adequate time to study supplementary agenda on Dynamic compensation Devices.

In this regard, a joint study has been carried out by CEA and POWERGRID. The study report on Static VAR Compensators (SVC) requirement on All India basis is uploaded at CEA website (www.cea.nic.in) at the following link : Home Page – Wing Specific Document-Power Systems-Standing Committee on Power System Planning.

Yours faithfully,

(K.K. Arya)

Chief Engineer (I/C)(SP&PA)

Report on Static VAR Compensators (SVC) requirements

1.0 Background

In the recent past, two major grid disturbances had been experienced in NEW grid on 30-07-2012 and 31-07-2012. An Enquiry Committee under the chairmanship of Chairperson, CEA was constituted by Ministry of Power to analyze the causes of these disturbances and to suggest measures to avoid recurrence of such disturbances in future. Based on the analysis of these grid disturbances, the committee inter-alia recommended:

“In order to avoid frequent outages / opening of lines under over voltages and also providing voltage support under steady state and dynamic conditions, installation of adequate static and dynamic reactive power compensators should be planned”.

Based on the observations and recommendations of the Expert Committee on these grid disturbances, studies have been carried out to assess the requirement of dynamic reactive power compensators on all-India basis. The studies were carried out jointly by CEA and POWERGRID at POWERGRID office. The details of the studies are given below:

2.0 Static Var Compensator (SVC)

A Static Var Compensator (SVC) is a parallel combination of controlled shunt reactor and capacitor to regulate the voltage at a bus, where it is installed. The arrangement shown in Figure–1 below, is that of a controlled shunt reactor in which thyristors are in series with a reactor that directly control the current flow through the reactor. The effect of controlled firing of the thyristors is to control the effective fundamental frequency admittance of the thyristor-reactor unit as seen from its high-voltage terminals.

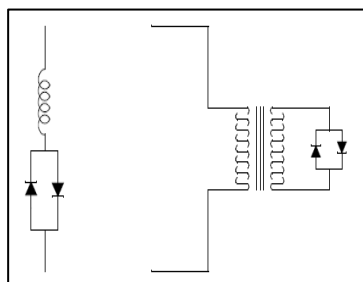

Figure-1

Figure-2 below shows the arrangement of combination of controlled reactor in parallel to shunt capacitor.

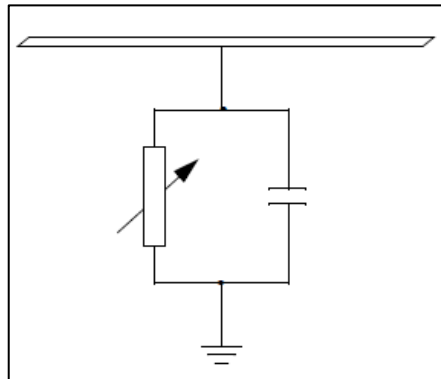

Figure-2

- With the reactor turned “off” through thyristor switching, the installation is a shunt capacitor that will supply reactive power to the system.
- The reactor may be turned “on” in controlled fashion to absorb reactive power of varying quantum, thereby the effective value of reactive VARs absorbed from the system or supplied to the system can be controlled.

The characteristics of the combined controlled shunt reactor and capacitor is as shown below, wherein, it may be seen that in the normal operating range of voltages, the SVC provides a near flat characteristics for the reactive power generated/absorbed.

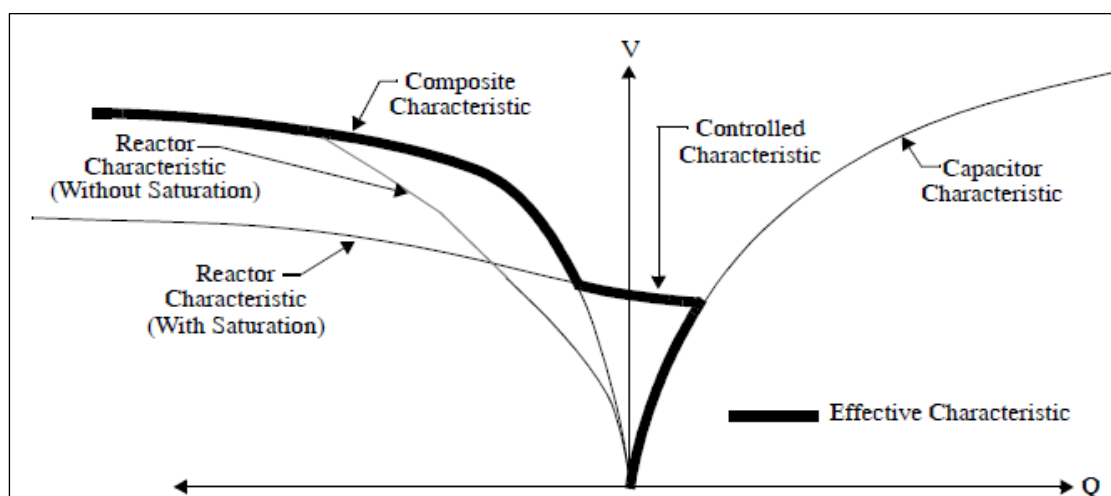

Figure-3

The Static VAR Compensator (SVC) facilitates enhanced voltage stability by providing reactive power support to the power system. **Voltage stability** is the ability of a system to maintain steady acceptable voltages at all the buses in the system at all conditions. The ability to transfer reactive power from production source to consumption areas during steady-state operating conditions is a major problem of voltage stability. A system mainly enters a state of voltage instability when a disturbance, increase in load demand, or change in system condition cause a progressive and uncontrollable decline in voltage.

This situation of Voltage instability can be avoided by: (a) appropriate load shedding on the consumer network; (b) on load tap changers; (c) adequate reactive compensation (series and/or shunt). Therefore, the key contributing factor in voltage collapse is the rapid and progressive loss of voltage controllability due to reactive limit violations.

Besides above, SVC also helps in Steady State voltage control, Dynamic voltage control during disturbance, reduction of temporary & dynamic overvoltage, improving transient stability and damping of power oscillations.

3.0 System Studies for Static Var Compensator (SVC)

3.1 Assumptions for base case :

The system studies were performed considering all India network corresponding to 2016-17 time frame peak load condition to evaluate the dynamic support requirements and the load flow study results for the same are enclosed at Exhibit-1-A to 1-D. This was done to get an understanding of the severity of the contingencies and identify the critical contingencies from a dynamic standpoint. The worst case scenario was identified to be a three phase fault and tripping of critically loaded transmission line. Summary of the base Load flow case depicting Load Generation Balance and inter-regional transfers are given in following tables.

Table -1: Load Generation Balance

(All in MW)	Self Generation	Load	Net Inter Change	Losses
North	47764.2	59482.2	-13316.2	1714.4
North East	3834.4	2865.7	857	111.8
West	69270.1	60263.8	6649.9	2356.5
East	38765.4	23724.5	14105.8	935
South	48157.1	55858.8	-8296.4	1594.7
Wind Gen	0	-1000	0	0
Total	207791	201195	0	6712.3

Table-2: inter-regional transfers

To Area →	North	North East	West	East	South
From Area					
North			-4536	-8780	
North East				857	
West	4536			-1775	3889
East	8780	-857	1775		4407
South			-3889	-4407	
Net Export (+) /Import(-)	13316	-857	-6650	-14105	8296

3.2 SVC model considered in the Study:

Following SVC model was taken in the dynamic study:

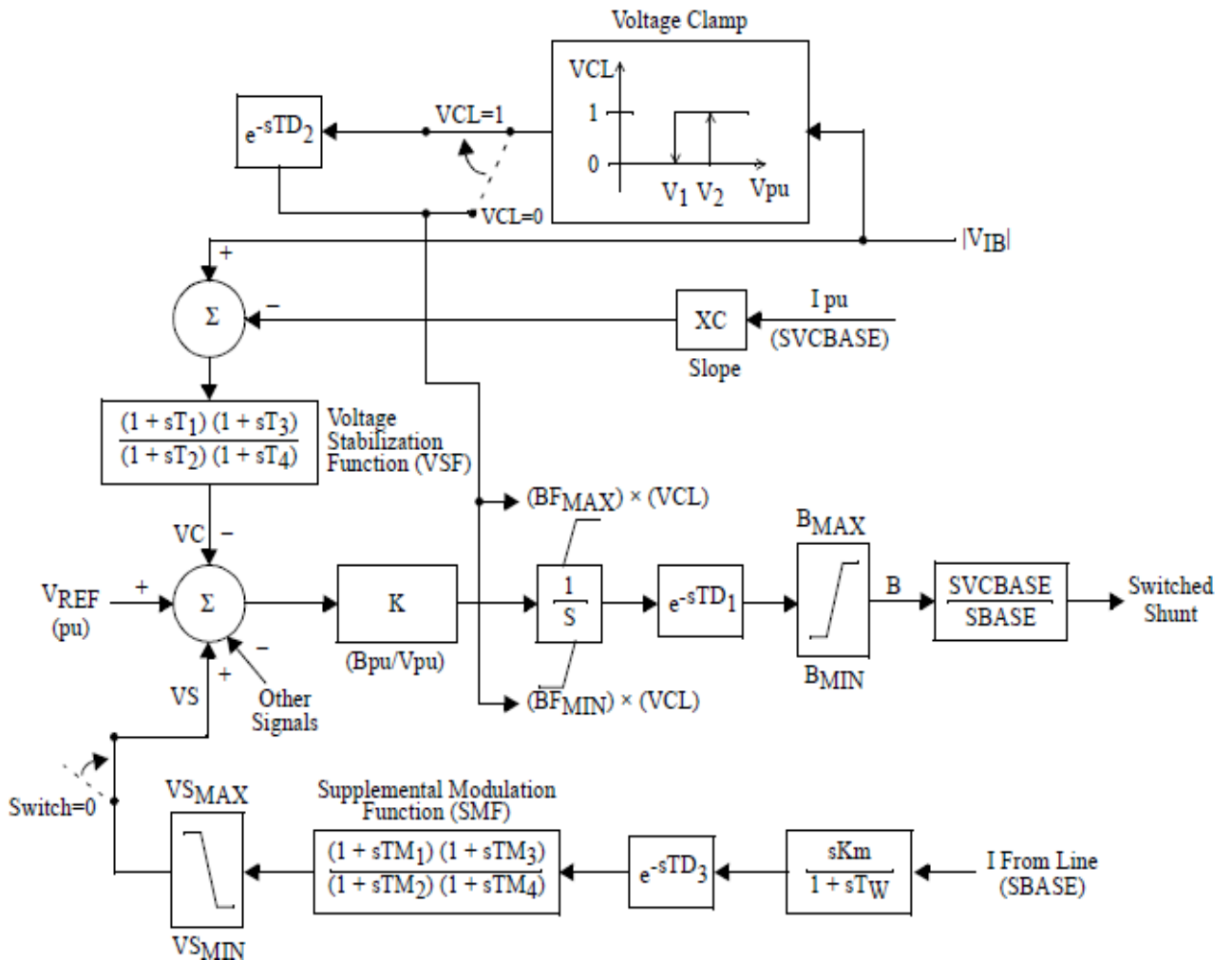

3.3 Voltage Profile Analysis for Selecting Candidate Locations:

The voltage profiles of all the existing 400kV inter-state transmission system (ISTS) buses in Northern, Western, Southern and Eastern Region were analysed. Candidate locations were identified based on voltage profile, short circuit level, interconnection with the grid, interconnection with generating station, location of existing / planned FACTS devices, space availability etc. It was observed that voltage variation at the following location were very high typically in the range of 40-60 kV and therefore, they were considered as suitable location for carrying out detailed system studies to test the requirement of SVC at these buses.

a) Northern Region:

- | | |
|-------------|-----------------|
| i) Nalagarh | ii) Fatehpur |
| iii) Hissar | iv) New Lucknow |

b) Western Region:

- | | |
|----------------------|-------------------|
| i) Solapur | ii) Seoni |
| iii) Indore (PG) | iv) Kolhapur (PG) |
| v) Gwalior | vi) Satna |
| vii) Aurangabad (PG) | viii) Bina |

c) Southern Region:

- | | |
|-----------------------------|---------------|
| i) Hyderabad (PG) | ii) Cuddapah |
| iii) Gooty | iv) Udumalpet |
| v) Hosur | vi) Trichy |
| vii) Somanhally (Bangalore) | |

d) Eastern Region:

- | | |
|-------------------|-----------------|
| i) Rourkela | ii) Muzaffarpur |
| iii) Ranchi (New) | iv) Gaya |
| v) Kishenganj | vi) Patna |

In addition to above candidate locations, following existing / approved SVCs in Northern Region were also modelled while carrying out the studies.

Existing : Kanpur (2 x ±140 MVAR)

Already Approved :

- i) New Wanpoh (+300 / - 200 MVAR)
- ii) Ludhiana (+600 / - 400 MVAR)
- iii) Kankroli (+400 / - 300 MVAR)

The voltages observed during past one year or so (based on data received from POSOCO) at the candidate locations as indicated above are tabulated below:

a) Northern Region:

Substation	Jul'11	Aug'11	Sep'11	Oct'11	Nov'11	Dec'11	Jan'12	Feb'12	Mar'12	Yearly Max.
Maximum Voltage (kV)										
Hissar	415	416	418	431	417	424	416	430	424	431.4
Nalagarh	424	438	423	436	433	431	432	429	431	438.2
Substation	Mar'12	Apr'12	May'12	Jun'12	Jul'12	Aug'12	Sep'12	Oct'12	Nov'12	Yearly Max.
Lucknow	428	429	429	427	430	429	431	429	429	431
Fathepur	424	425	424	428	429	431	433	429	430	432.5
Substation	Jul'11	Aug'11	Sep'11	Oct'11	Nov'11	Dec'11	Jan'12	Feb'12	Mar'12	Yearly Min.
Maximum Voltage (kV)										
Hissar	381	383	383	371	362	359	355	362	376	351.2
Nalagarh	377	388	388	402	402	401	401	401	401	377.2
Substation	Mar'12	Apr'12	May'12	Jun'12	Jul'12	Aug'12	Sep'12	Oct'12	Nov'12	Yearly Min.
Lucknow	419	418	418	416	417	421	418	420	421	416
Fathepur	386	393	391	390	390	405	405	402	404	386

b) Western Region:

Substation	Oct'11	Nov'11	Dec'11	Jan'12	Feb'12	Mar'12	Apr'12	Jun'12	Jul'12	Average
Maximum Voltage (kV)										
Solapur	438	440	435	438	436	440	436	435	440	438
Seoni	424	425	420	431	424	435	402	432	430	425
Indore	424	423	421	429	424	426	426	426	423	425
Kolhapur	431	431	432	432	429	430	428	429	432	430
Gwalior	422	426	425	425	423	425	427	413	416	422
Satna	417	422	417	424	414	424	422	417	421	420
Aurangabad	424	424	423	433	427	429	429	422	438	428
Bina (PG)	424	426	423	430	422	430	432	420	424	426

Minimum Voltage(kV)										
Solapur	380	404	387	387	398	399	391	385	400	392
Seoni	411	403	403	404	408	414	402	425	419	410
Indore	404	392	393	399	407	405	407	406	410	403
Kolhapur	404	407	406	406	401	406	402	401	402	404
Gwalior	401	403	404	402	388	391	401	394	391	397
Satna	396	405	401	402	399	401	398	404	400	401
Aurangabad	396	384	387	400	399	400	399	399	409	397
Bina (PG)	399	401	403	403	397	402	403	403	402	401

c) Southern Region:

Substation	Dec'11	Jan'12	Feb'12	Mar'12	Apr'12	May'12	Jun'12	Jul'12	Aug'12	Sep'12	Average
Maximum Voltage (kV)											
Cudappah	428.0	425.0	426.0	420.0	423.3	420.4	422.7	425.6	431.5	433.2	426.3
Gooty	427.0	430.0	432.0	422.0	428.7	426.4	430.5	430.5	434.0	436.3	429.8
Hosur	425.5	415.0	429.0	413.0	414.4	415.6	409.1	413.8	418.5	421.4	419.7
Hyderabad	437.0	437.0	435.0	430.0	430.9	426.8	436.8	436.8	436.8	437.9	434.6
Somanhalli	420.0	419.0	421.0	416.0	418.5	420.3	417.9	422.4	426.8	427.3	421.2
Trichy	416.7	411.5	416.1	412.0	411.5	412.6	410.9	407.9	412.0	416.7	413.4
Udumalpeth	416.4	415.8	421.1	415.0	417.6	417.0	417.0	416.4	418.8	425.2	418
Minimum Voltage (kV)											
Cudappah	397.0	395.0	393.0	386.0	384.0	386.4	384.6	388.7	394.6	394.5	391.4
Gooty	403.0	398.0	401.0	396.0	394.8	400.6	401.2	403.0	407.1	401.1	401.2
Hosur	388.0	388.0	384.5	378.0	378.6	374.5	374.0	381.6	383.3	383.3	384.1
Hyderabad	413.0	405.0	405.0	399.0	396.9	397.5	406.3	409.8	408.0	411.6	406
Somanhalli	367.0	374.0	372.0	368.0	366.8	367.4	373.1	374.9	382.8	386.3	374.4
Trichy	366.3	390.4	391.5	383.0	374.0	373.4	370.4	367.5	372.2	373.4	377.6
Udumalpeth	352.6	384.2	383.0	384.0	376.0	376.0	369.0	366.1	370.2	373.7	374.6

d) Eastern Region:

Substation	Aug'11	Sep'11	Dec'11	Jan'12	Feb'12	Apl'12	May'12	Jun'12	Jul'12	Average
Maximum Voltage (kV)										
Biharsharif	429	429	431	434	431	431	427	426	429	429.57
Rourkela	427	428	434	430	432	428	427	428	429	429.07
Ranchi	426	429	431	431	432	428	431	431	432	430.09
Muzaffarpur	431	433	431	436	431	430	424	426	426	429.90
Jamshedpur	429	430	428	430	431	432	429	429	433	430.10
Durgapur	426	425	429	429	429	426	423	424	427	426.25
Minimum Voltage(kV)										
Biharsharif	391	397	398	405	400	396	392	386	392	395.20
Rourkela	407	408	412	415	412	408	412	410	406	409.96
Ranchi	408	408	414	418	416	411	416	415	400	411.71
Muzaffarpur	394	395	399	401	401	392	388	381	386	393.00
Jamshedpur	408	403	411	411	410	412	413	412	407	409.67
Durgapur	406	403	414	411	411	410	410	409	405	408.61

3.4 Fault Level Analysis for Selecting Candidate Locations:

The short circuit level and pre-fault voltage at the above selected candidate locations are given below:

S. No.	Bus Name	Voltage (kV)	Short Circuit (GVA/kA)	Stability Study Plots (Exhibit no.)
Northern Region:				
1	Nalagarh	403.6	19.3 / 27.8	Exhibit-1
2	Fatehpur	401.2	28.6 / 41.3	Exhibit-2
3	Hissar	402.6	30.8 / 44.5	Exhibit-3
4	New Lucknow	407.3	34.6 / 50.0	Exhibit-4
Western Region:				
1	Solapur	401.0	24.0 / 34.6	Exhibit-5
2	Seoni	401.0	23.6 / 34.0	Exhibit-6
3	Indore (PG)	403.0	19.7 / 28.5	Exhibit-7
4	Kolhapur (PG)	403.5	12.0 / 17.3	Exhibit-8
5	Gwalior	403.3	16.6 / 24.0	Exhibit-9
6	Satna	405.1	27.2 / 39.3	Exhibit-10
7	Aurangabad (PG)	406.2	30.0 / 43.3	Exhibit-11
8	Bina	401.9	29.0 / 41.8	Exhibit-12
Southern Region:				
1	Hyderabad (PG)	386.9	18.4 / 26.5	Exhibit-13
2	Cuddapah	392.6	9.8 / 14.2	Exhibit-14
3	Gooty	400.0	20.4 / 29.5	Exhibit-15
4	Udumalpet	403.2	19.4 / 28.0	Exhibit-16
5	Hosur	401.7	18.6 / 26.8	Exhibit-17
6	Trichy	403.7	12.5 / 18.0	Exhibit-18
7	Somanhally	399.6	19.3 / 27.9	Exhibit-19
Eastern Region:				
1	Rourkela	404.3	25.5 / 36.8	Exhibit-20
2	Muzaffarpur	401.0	16.1 / 23.3	Exhibit-21
3	Ranchi (New)	403.8	32.2 / 46.5	Exhibit-22
4	Gaya	403.0	36.0 / 52.0	Exhibit-23
5	Kishanganj	405.1	20.2 / 29.2	Exhibit-24

4.0 Analysis of Dynamic Simulation Studies

The dynamic simulation studies have been carried out in order to examine the effect of dynamic compensation under system disturbances at the above mentioned substations. The results of the studies are shown at exhibits as indicated against the each substation above. Analysing the effect of SVCs in stabilizing the voltage and damping of the oscillations, following SVCs are proposed to be implemented in the first phase. For the initial studies ± 600 MVAR size was considered at all the candidate

location taking one SVC at a time. The study plots indicate that though the SVCs try to use its maximum range / rating in first swing, the actual MVAR usage of SVC in subsequent swings is generally in the range of ± 200 to ± 250 MVAR. Considering this, a size of ± 400 MVAR may be an optimum size, which would also give additional benefit of ± 150 to ± 200 MVAR in steady state operation in improving the voltage profile. Next set of studies were carried out considering all the SVCs simultaneously at proposed locations including 4 no. existing / approved SVCs in Northern Region. In this set of studies, the size of SVC was taken as ± 400 MVAR at the new proposed locations. Plots of stability studies at these locations are depicted in the exhibits as per following table:

S. No.	Bus Name	Study Plots (Exhibit no.)
Northern Region:		
1	Kanpur (existing)	Exhibit-25
2	New Wanpoh (approved)	Exhibit-26
3	Ludhiana (approved)	Exhibit-27
4	Kankroli (approved)	Exhibit-28
5	Fatehpur	Exhibit-29
Western Region:		
1	Solapur	Exhibit-30
2	Gwalior	Exhibit-31
3	Aurangabad (PG)	Exhibit-32
4	Satna	Exhibit-33
Southern Region:		
1	Hyderabad (PG)	Exhibit-34
2	Udumalpet	Exhibit-35
3	Trichy	Exhibit-36
Eastern Region:		
1	Rourkela	Exhibit-37
2	Ranchi(New)	Exhibit-38
3	Kishenganj	Exhibit-39

5.0 Conclusion

Based on the above considerations and studies, it is proposed that following eleven (11) nos. of SVCs may be considered in the first phase to meet the dynamic reactive power requirement at following sub-stations:

Sl.	Location	Rating
Northern Region:		
1.	Fatehpur	+ 400 MVAR, - 400 MVAR
Western Region:		

1.	Gwalior	+ 400 MVAR, - 400 MVAR
2.	Aurangabad	+ 400 MVAR, - 400 MVAR
3.	Solapur	+ 400 MVAR, - 400 MVAR
4.	Satna	+ 400 MVAR, - 400 MVAR
Southern Region:		
1.	Hyderabad	+ 400 MVAR, - 400 MVAR
2.	Udumalpet	+ 400 MVAR, - 400 MVAR
3.	Trichy	+ 400 MVAR, - 400 MVAR
Eastern Region:		
1.	Rourkela	+ 400 MVAR, - 400 MVAR
2.	Ranchi (New)	+ 400 MVAR, - 400 MVAR
3.	Kishenganj	+ 400 MVAR, - 400 MVAR

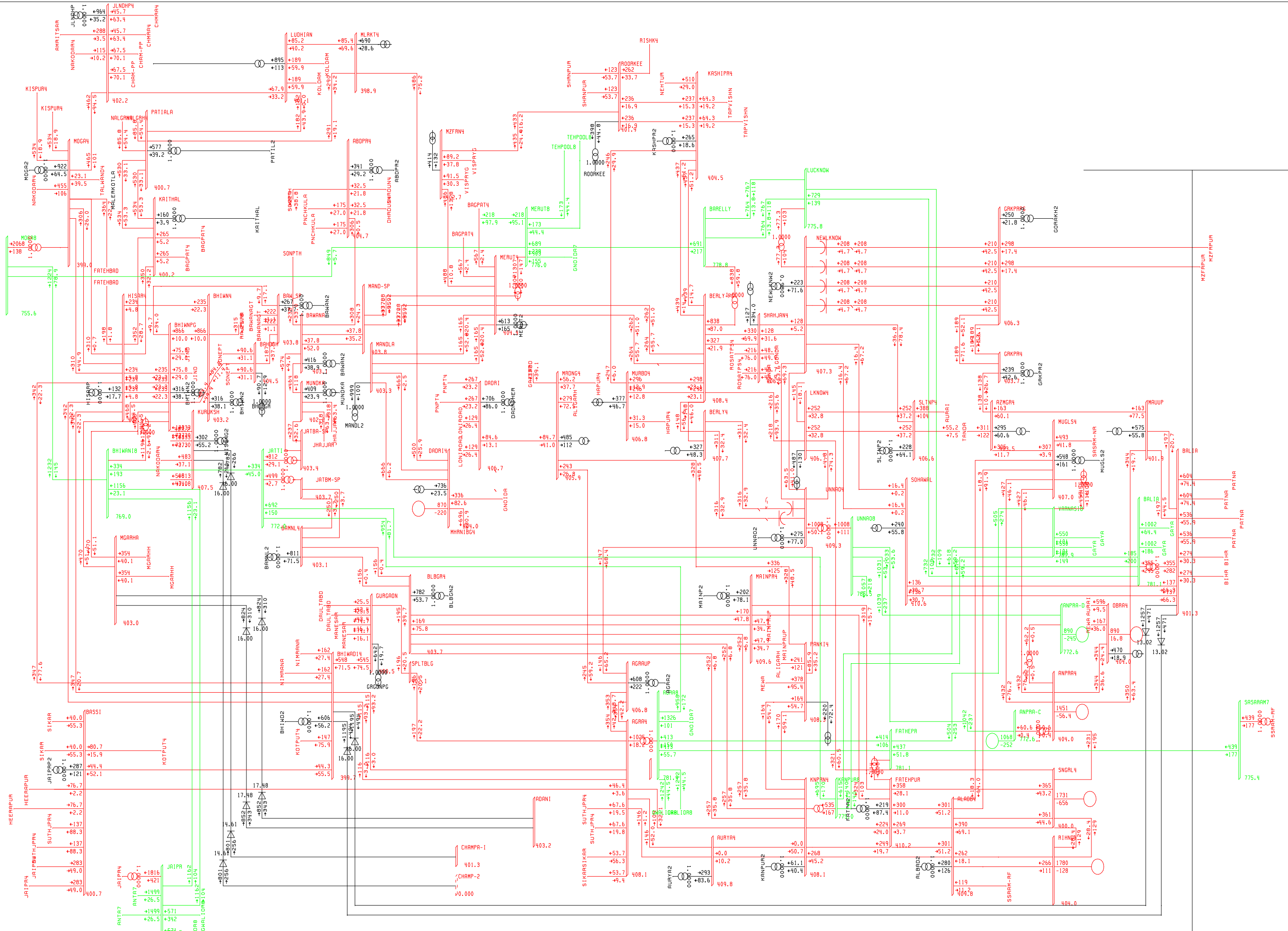

BUS - VOLTAGE (KV)
 BRANCH - MW/MVAR
 EQUIPMENT - MW/MVAR

KV: <220 , <400 , <765

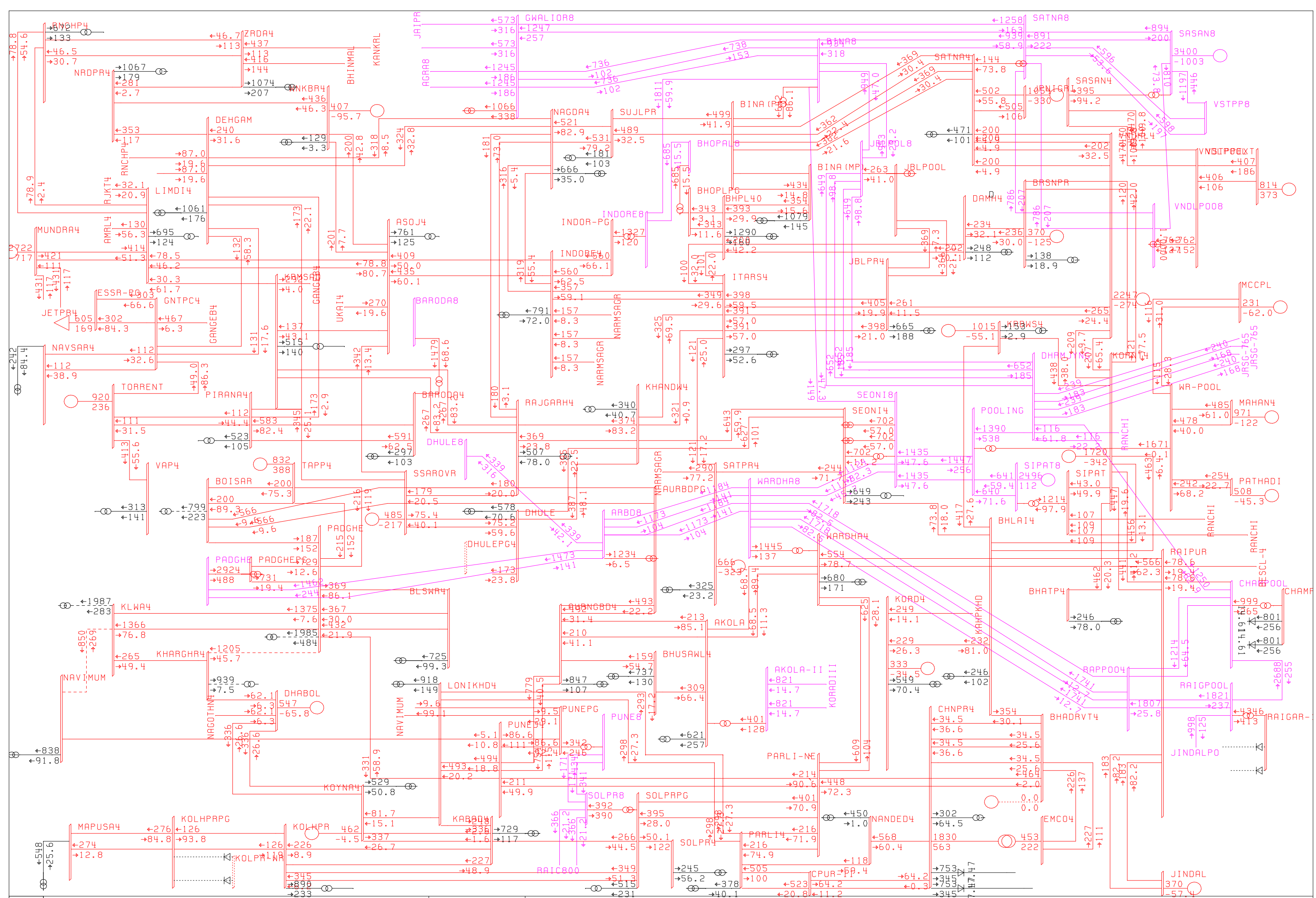

150% RATED
 0.900UV 1.050UV
 KV: $\leq 220, \leq 400, \leq 765$
 BUS - NONE
 BRANCH - MW/MVAR
 EQUIPMENT - MW/MVAR

SYSTEM STUDIES : Southern Region 2016-17

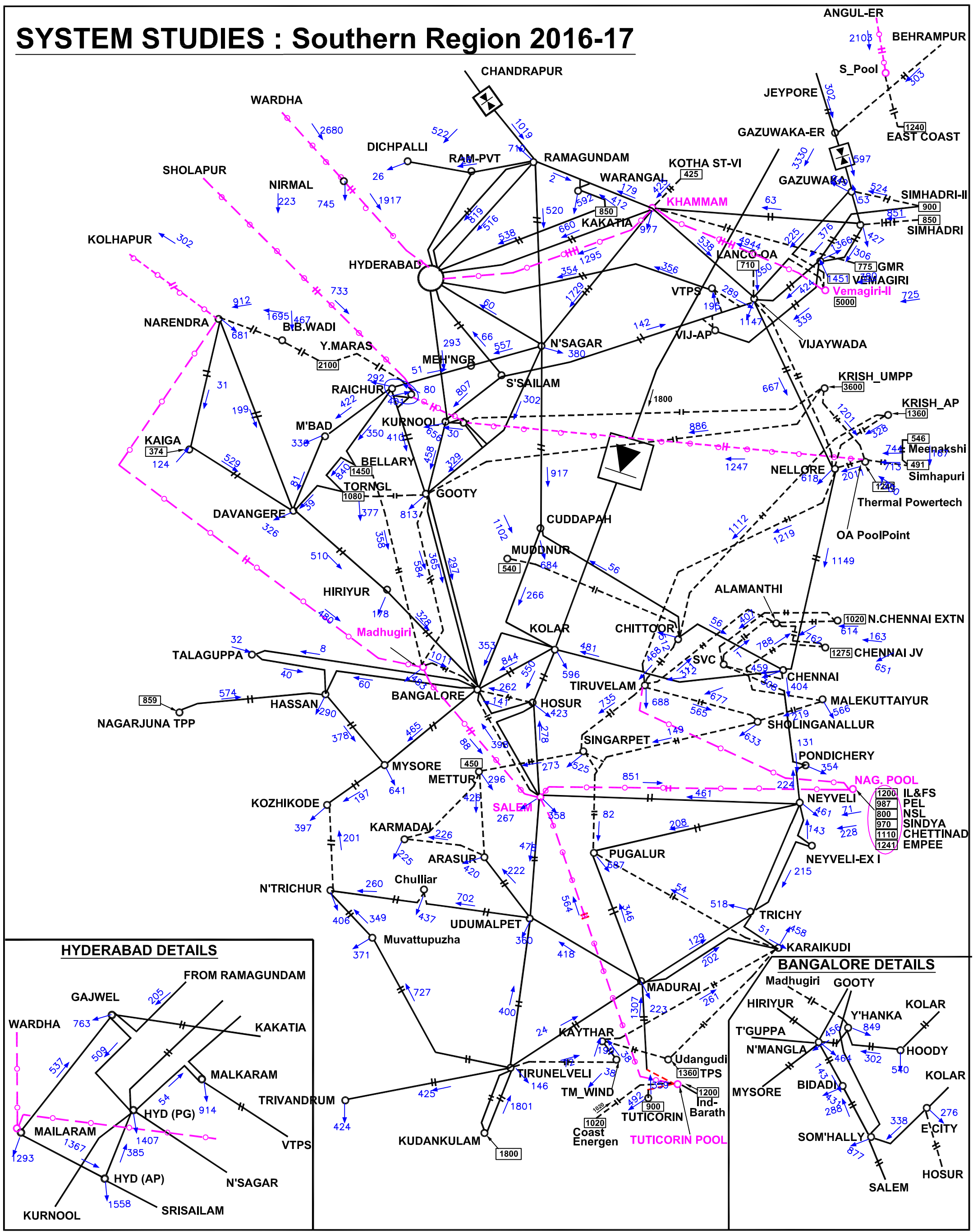

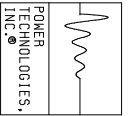

FAULT @ NALGRRH TRIP NALGRRH-KOLDAM

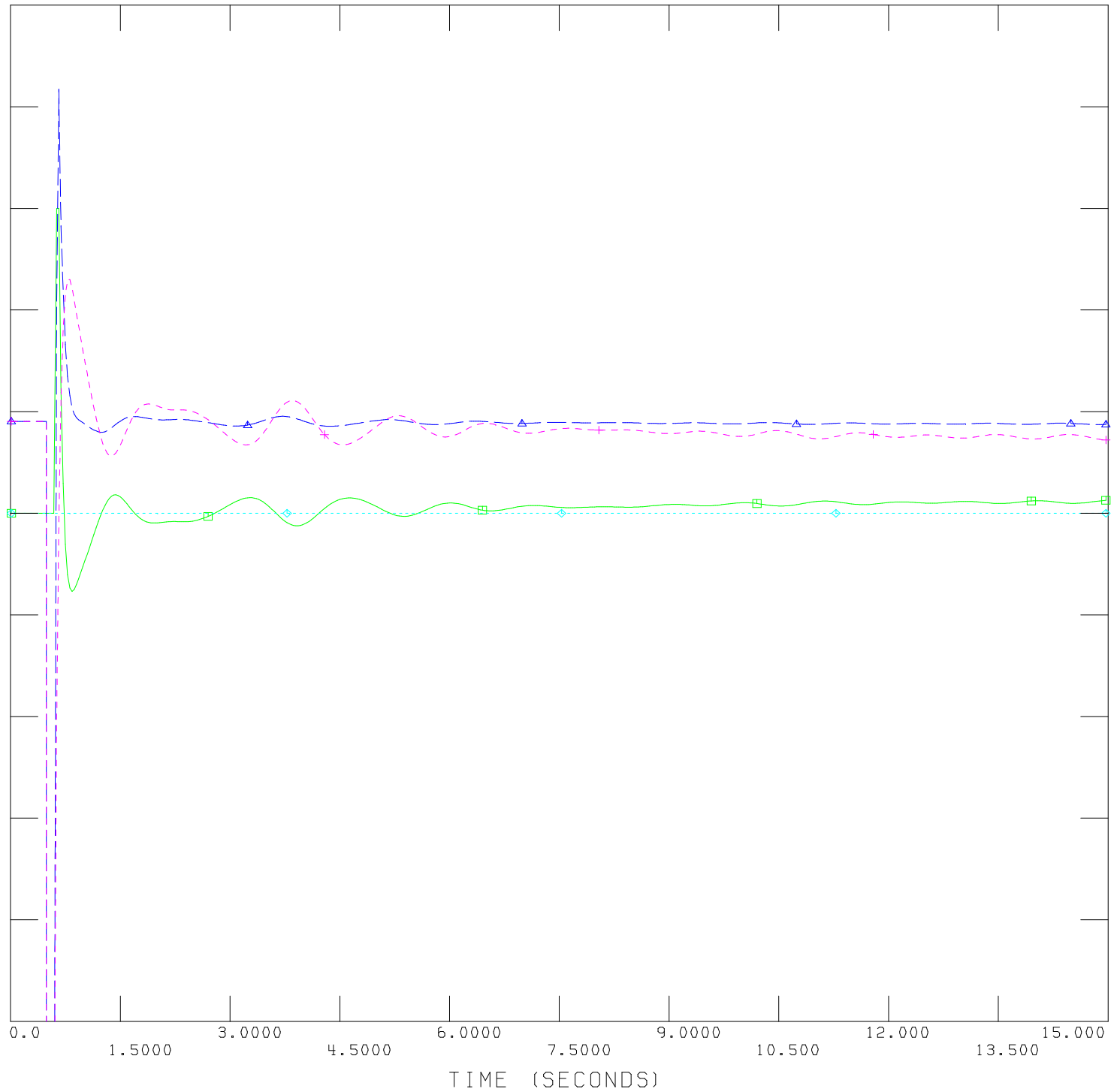

1.0500 FILE: NALR-W0-SVC.out CHNL# 307: CVLTG NALGRH4 -NORTHJ + 0.950000
10.000 FILE: NALR-W0-SVC.out CHNL# 892: [SVC_NALGRRHJ] -10.00
1.0500 FILE: NALR-W-SVC.out CHNL# 307: CVLTG NALGRH4 -NORTHJ -> 0.950000
10.000 FILE: NALR-W-SVC.out CHNL# 892: [SVC_NALGRRHJ] -10.00

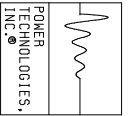

FAULT @ HISAR TRIP HISAR-KAITHAL

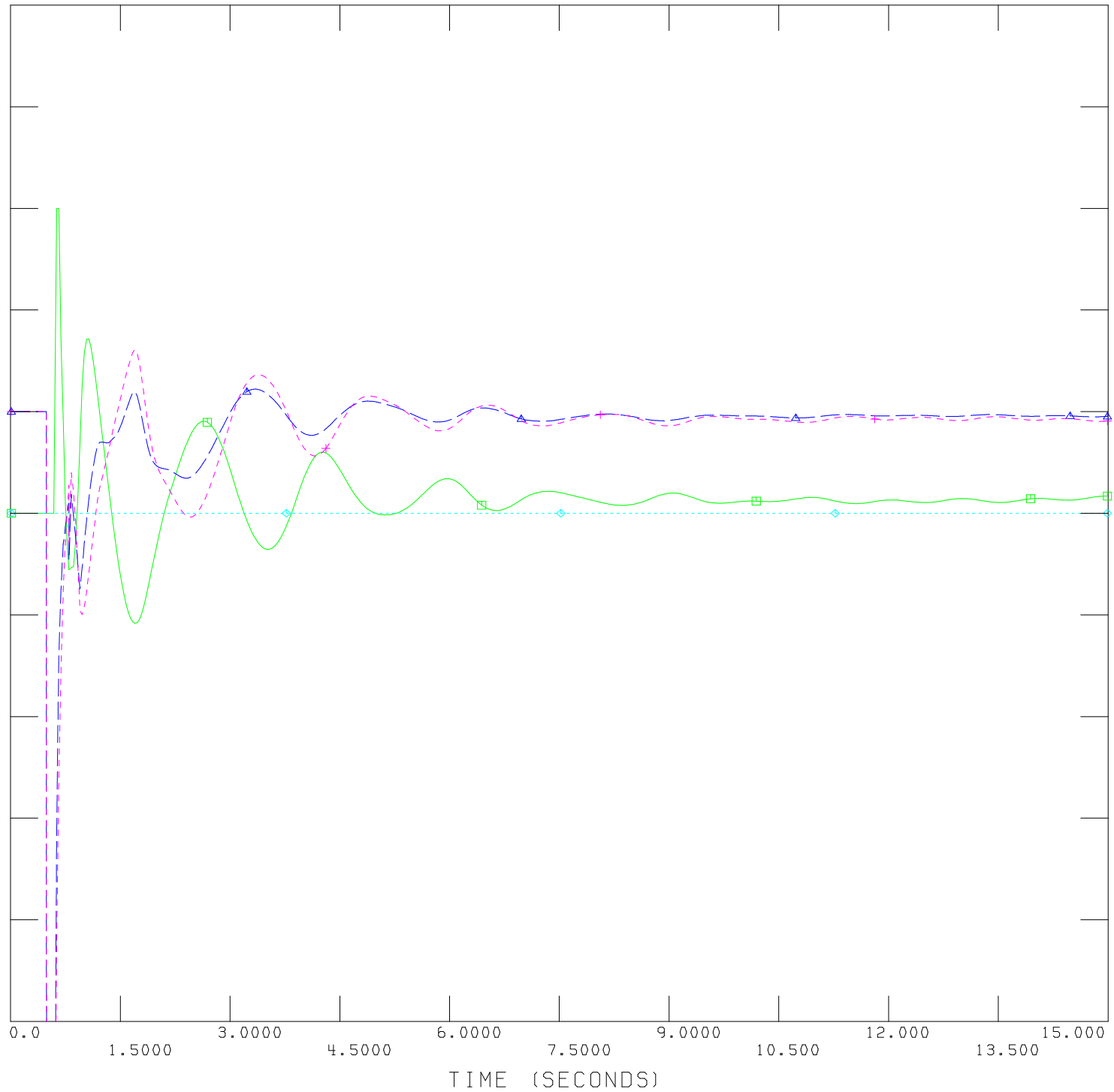

1.0500 FILE: HISR-W0-SVC.out CHNL# 338: CVLTG HISRTP -NORTH] +-----+ 0.950000
10.000 FILE: HISR-W0-SVC.out CHNL# 895: [SVC_HISAR]]
1.0500 FILE: HISR-W-SVC.out CHNL# 338: CVLTG HISRTP -NORTH] <-----< 0.950000
10.000 FILE: HISR-W-SVC.out CHNL# 895: [SVC_HISAR]] -10.00

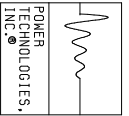

FAULT @ LUCKNOW TRIP LUCKNOW-SHAHJAHANPUR

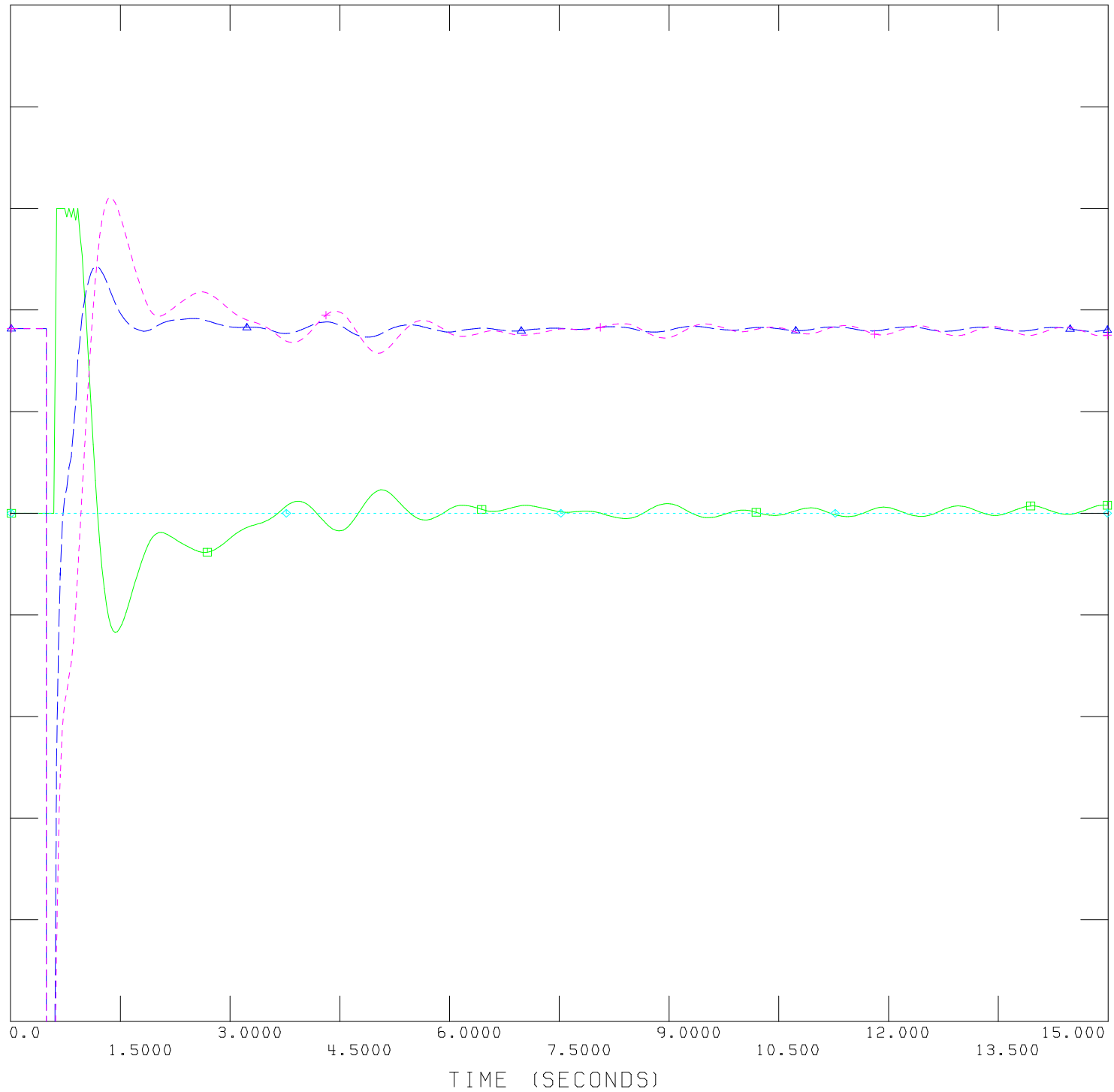

MON, DEC 17 2012 17:59

EXHIBIT-4

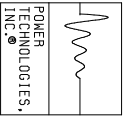

FAULT @ SOLAPUR TRIP SOLAPUR-RAICHUR #2

MON, DEC 17 2012 18:08
EXHIBIT-5

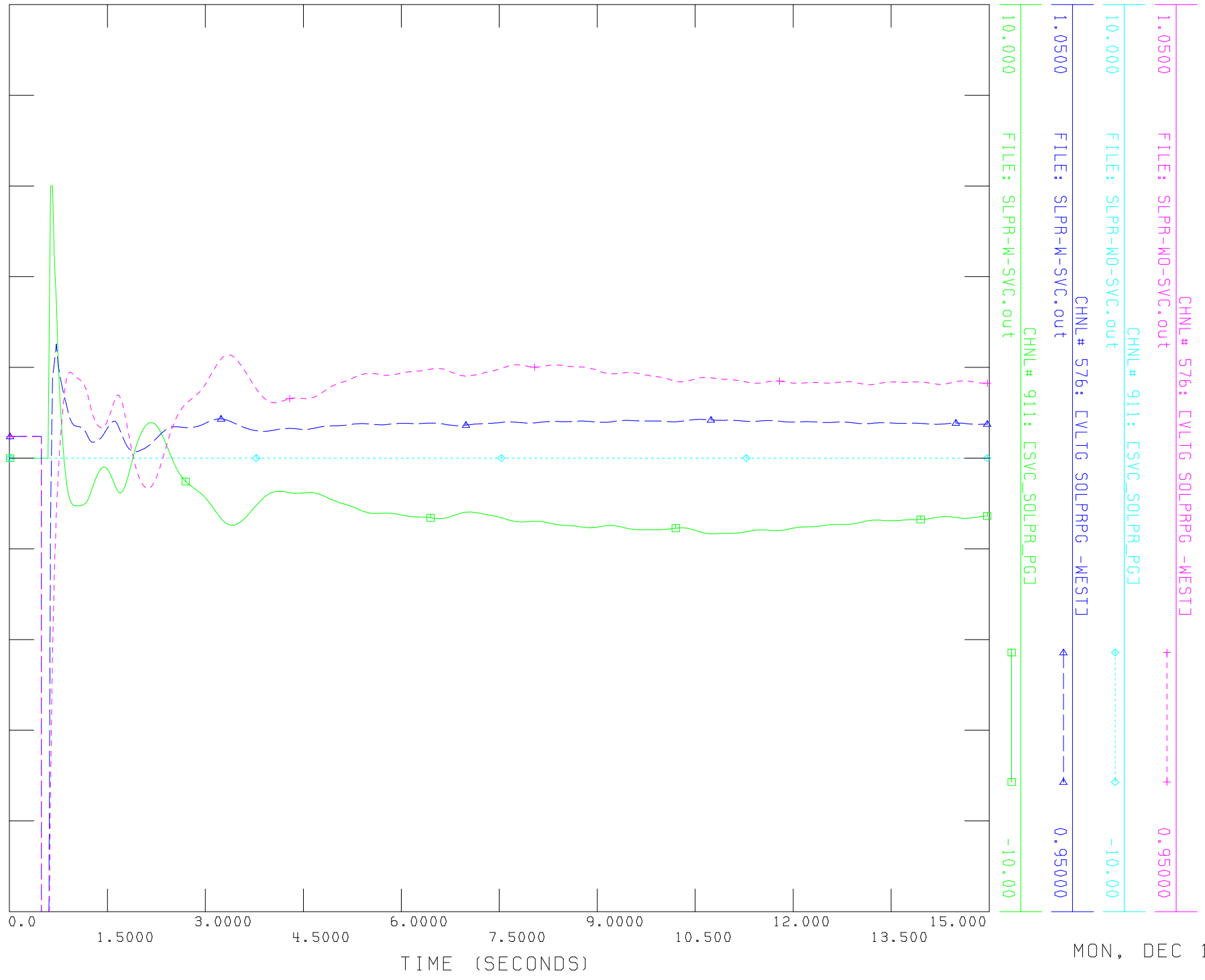

1.0500 CHNL# 576: CVLTG SOLPRPG -WESTJ +-----+ 0.95000
FILE: SLPR-W0-SVC.out
10.000 CHNL# 911: [SVC_SOLPR_PG] -10.00
FILE: SLPR-W0-SVC.out
1.0500 CHNL# 576: CVLTG SOLPRPG -WESTJ 0.95000
FILE: SLPR-W-SVC.out
10.000 CHNL# 911: [SVC_SOLPR_PG] -10.00
FILE: SLPR-W-SVC.out

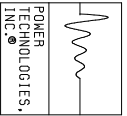

FAULT @ SEONI TRIP 765KV SEONI-BILASPUR 2

MON, DEC 17 2012 18:05

EXHIBIT-6

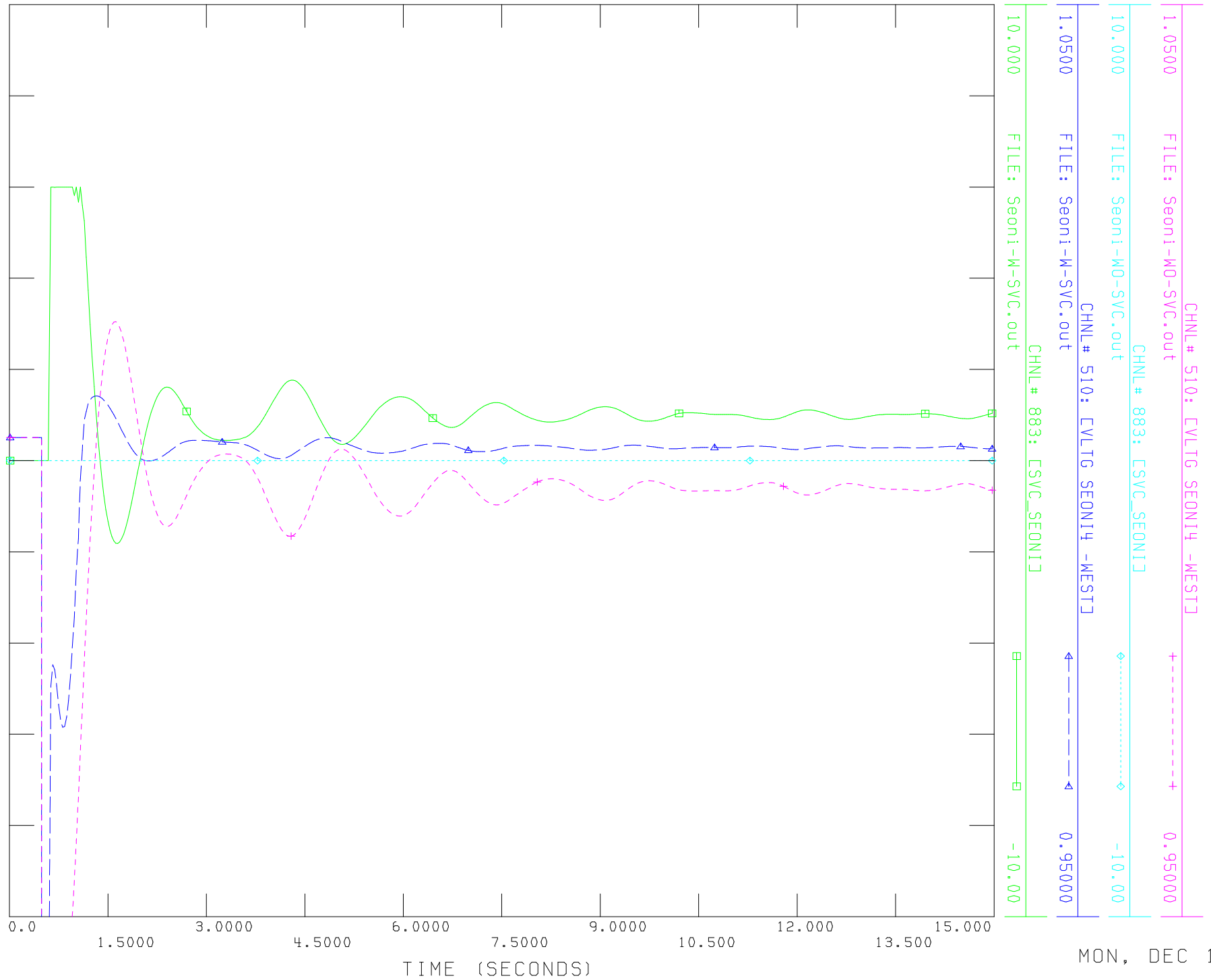

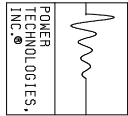

FAULT @ IND (PG) TRIP 765KV INDORE-BINN 1

MON, DEC 17 2012 18:09

EXHBIT-7

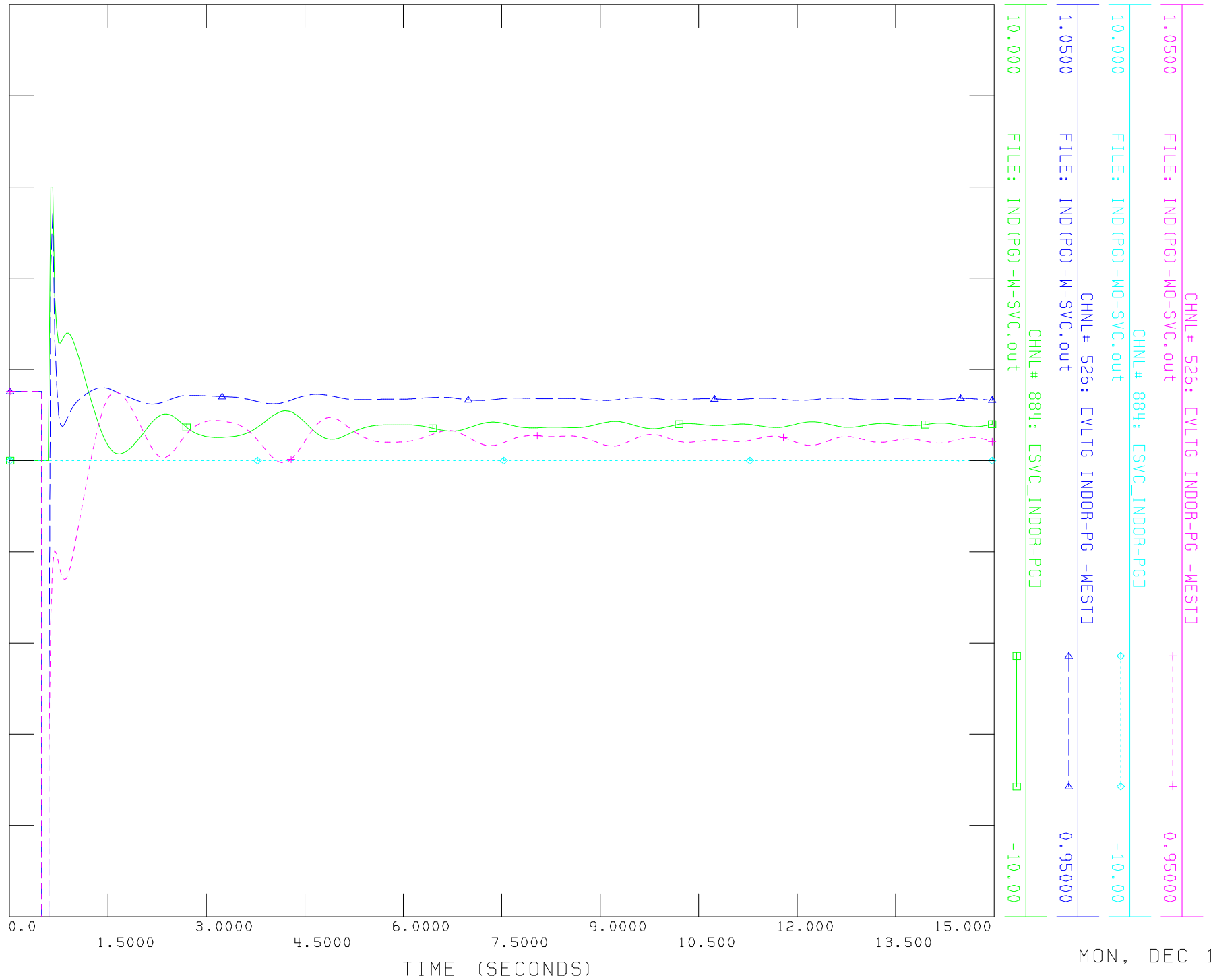

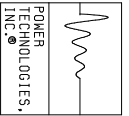

FAULT @ KOLHPR (PG) TRIP 400KV KOLHPR (PG) -MAPUSA 1

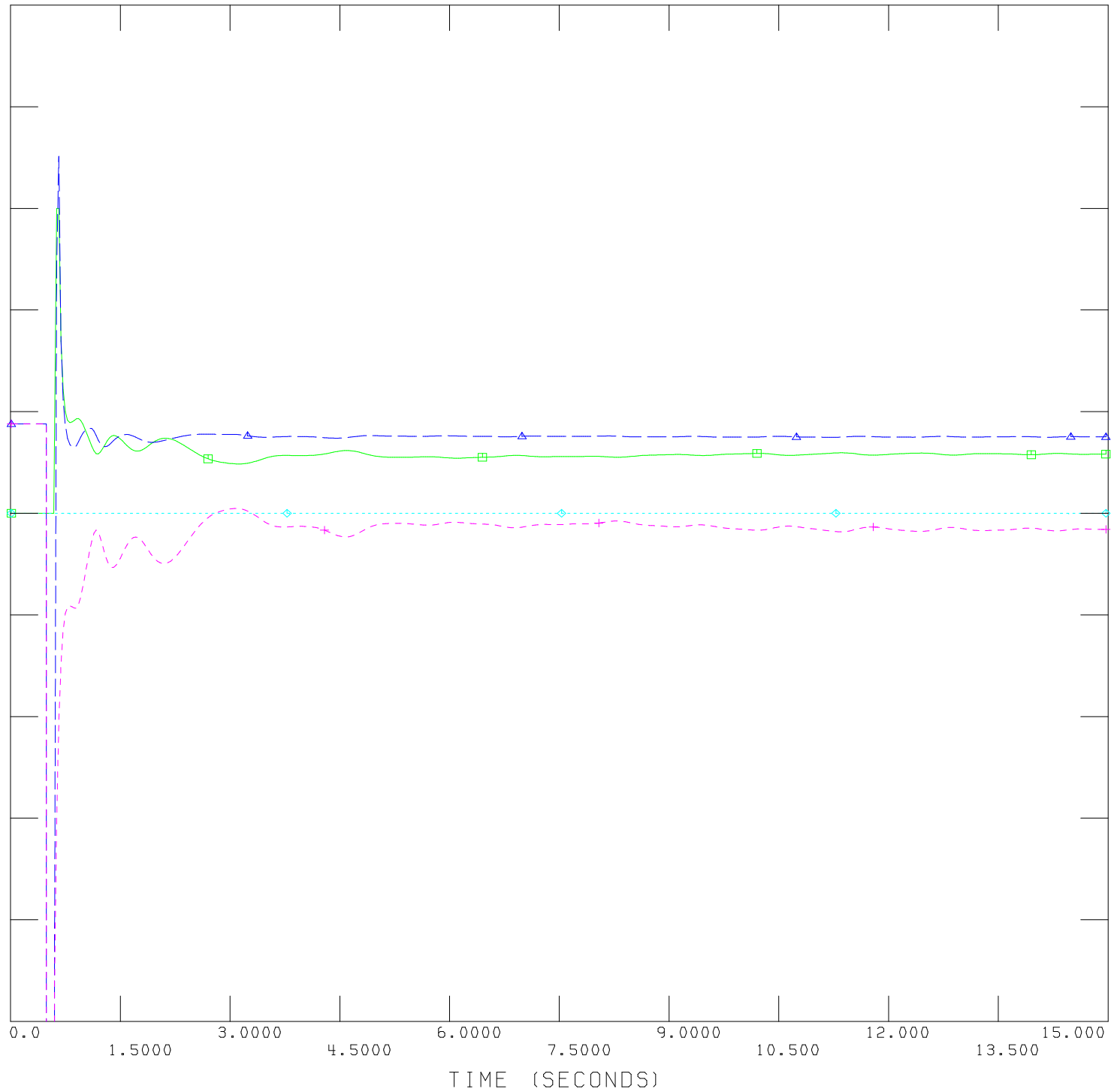

CHNL # 573: CVLTG KOLHPRPG -WESTJ +-----+ 0.95000
FILE: KOLHPR (PG) -M0-SVC.out
CHNL # 885: [SVC_KOLHR-PG] ◇-----◇ -10.00
FILE: KOLHPR (PG) -M0-SVC.out
CHNL # 573: CVLTG KOLHPRPG -WESTJ ▲-----▲ 0.95000
FILE: KOLHPR (PG) -M-SVC.out
CHNL # 885: [SVC_KOLHR-PG] ■-----■ -10.00
FILE: KOLHPR (PG) -M-SVC.out

MON, DEC 17 2012 18:12

EXHIBIT-8

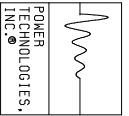

FAULT @ GWMLIOR TRIP 765KV GWMLIOR-ACRR 1

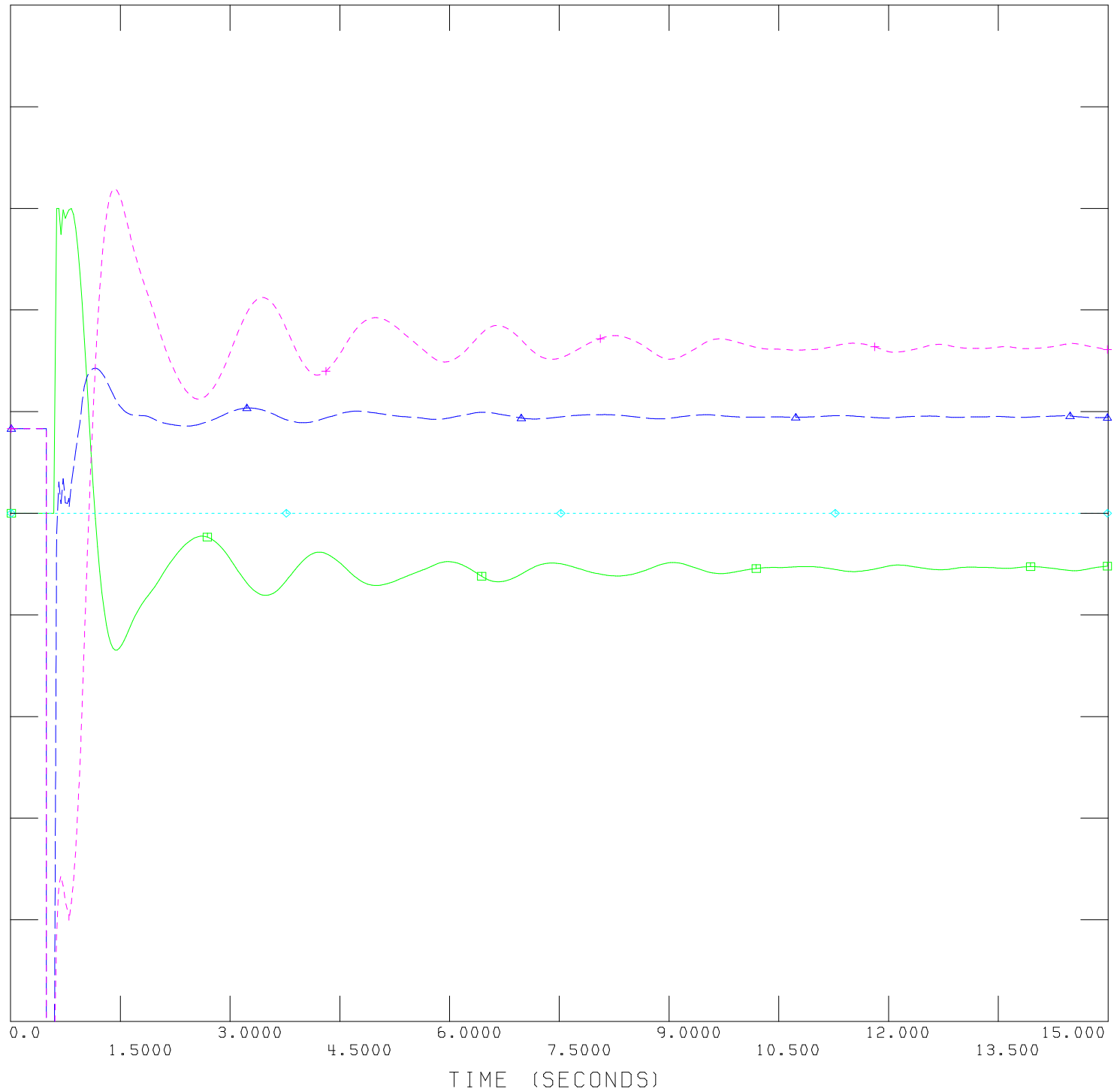

MON, DEC 17 2012 18:15

EXHIBIT-9

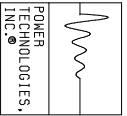

FAULT @ SATNA TRIP 765KV SATNA-GWALLIOR 1

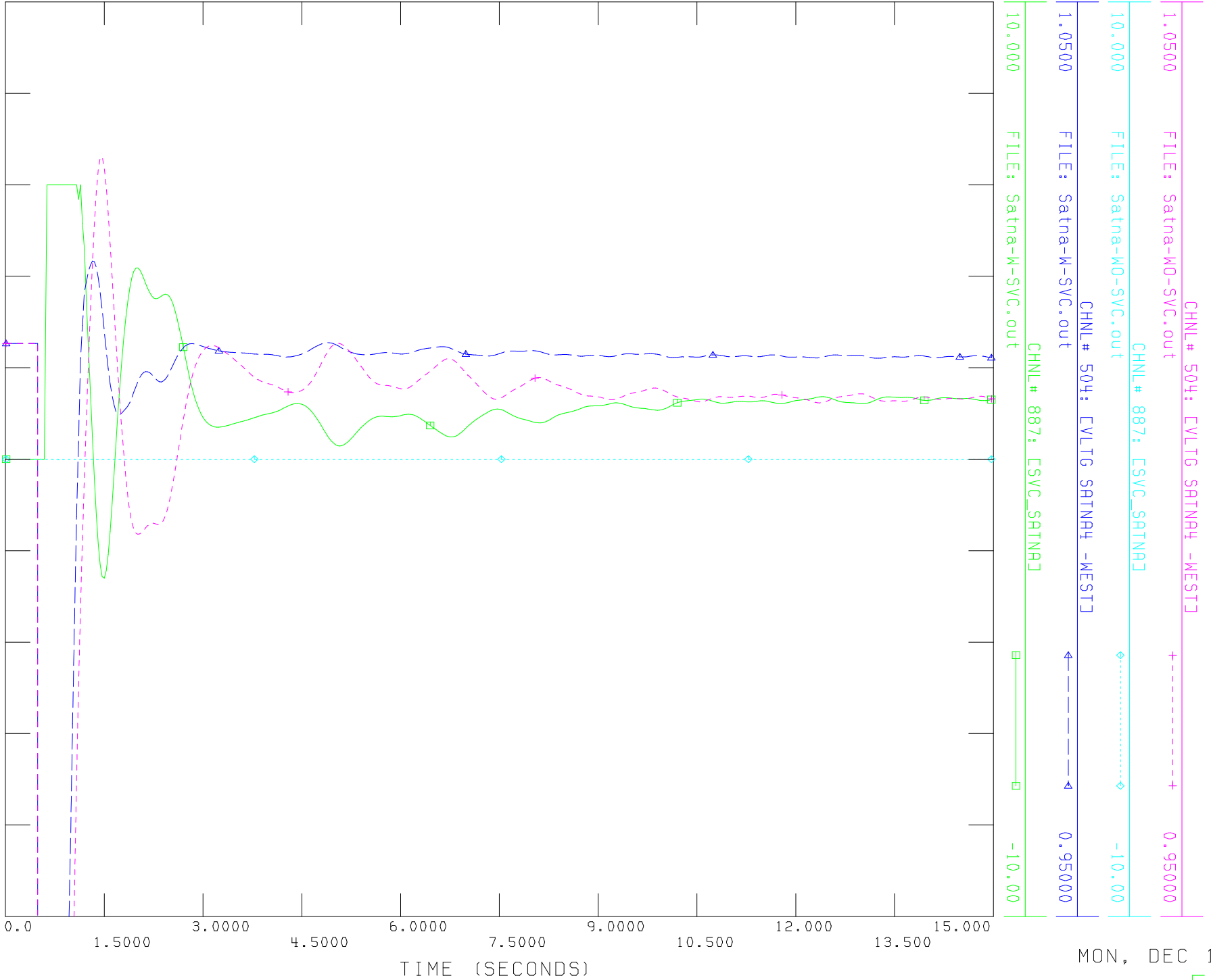
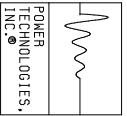
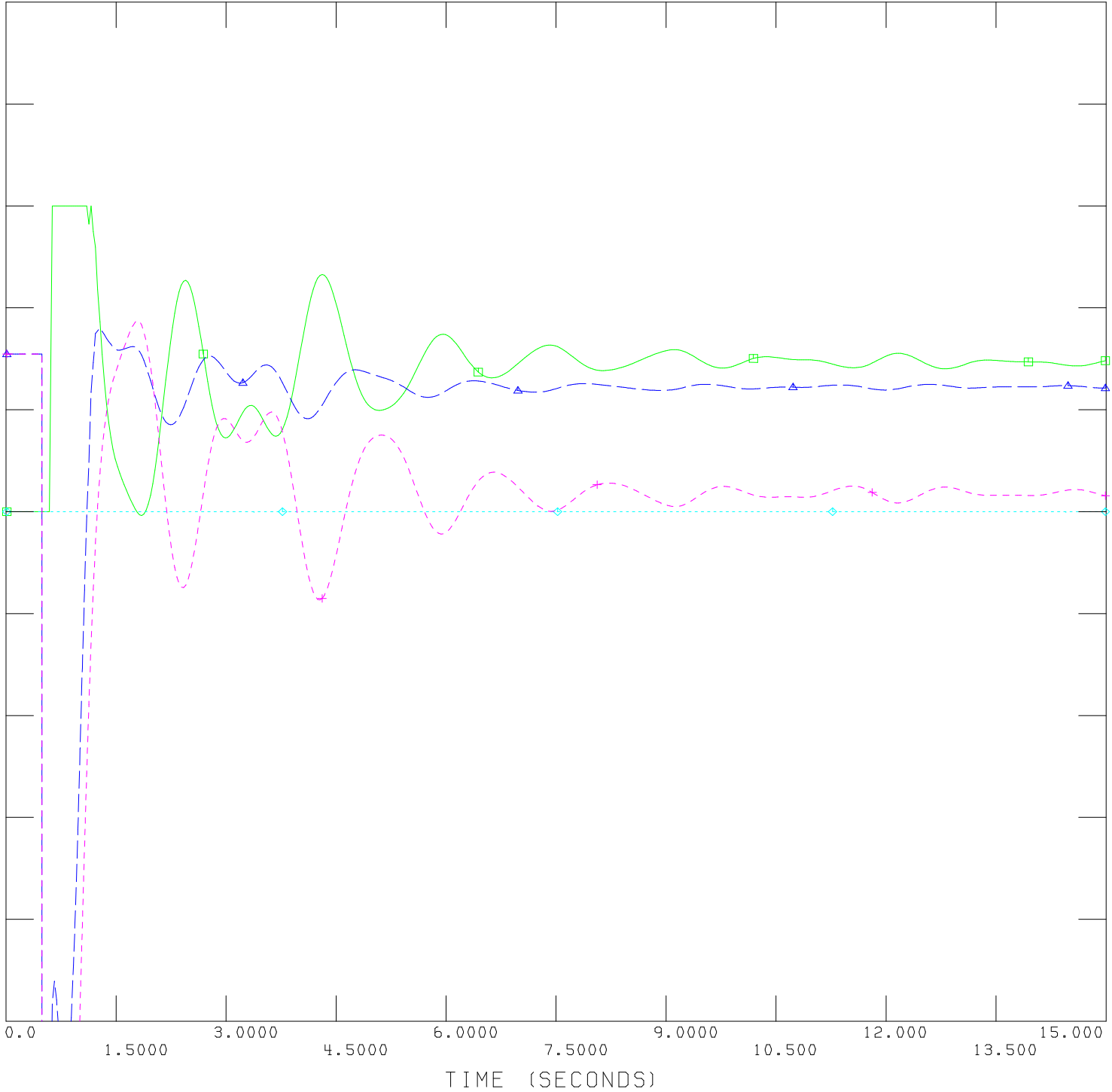

EXHIBIT-10



FAULT @ ARBD (PG) TRIP 765KV ARBD-PADGHE 1



1.0500 FILE: ARBD (PG) -M0-SVC.out CHNL# 595: CVLTG AURBDPG -WESTJ +-----+ 0.950000
10.000 FILE: ARBD (PG) -M0-SVC.out CHNL# 882: [SVC_AURNBD-PG]◇ -10.00
1.0500 FILE: ARBD (PG) -M-SVC.out CHNL# 595: CVLTG AURBDPG -WESTJ ◇-----◇ 0.950000
10.000 FILE: ARBD (PG) -M-SVC.out CHNL# 882: [SVC_AURNBD-PG] -----◇ -10.00

MON, DEC 17 2012 18:22

EXHIBIT-11

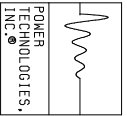

FAULT @ BINN TRIP 765KV BINN-INDORE 1

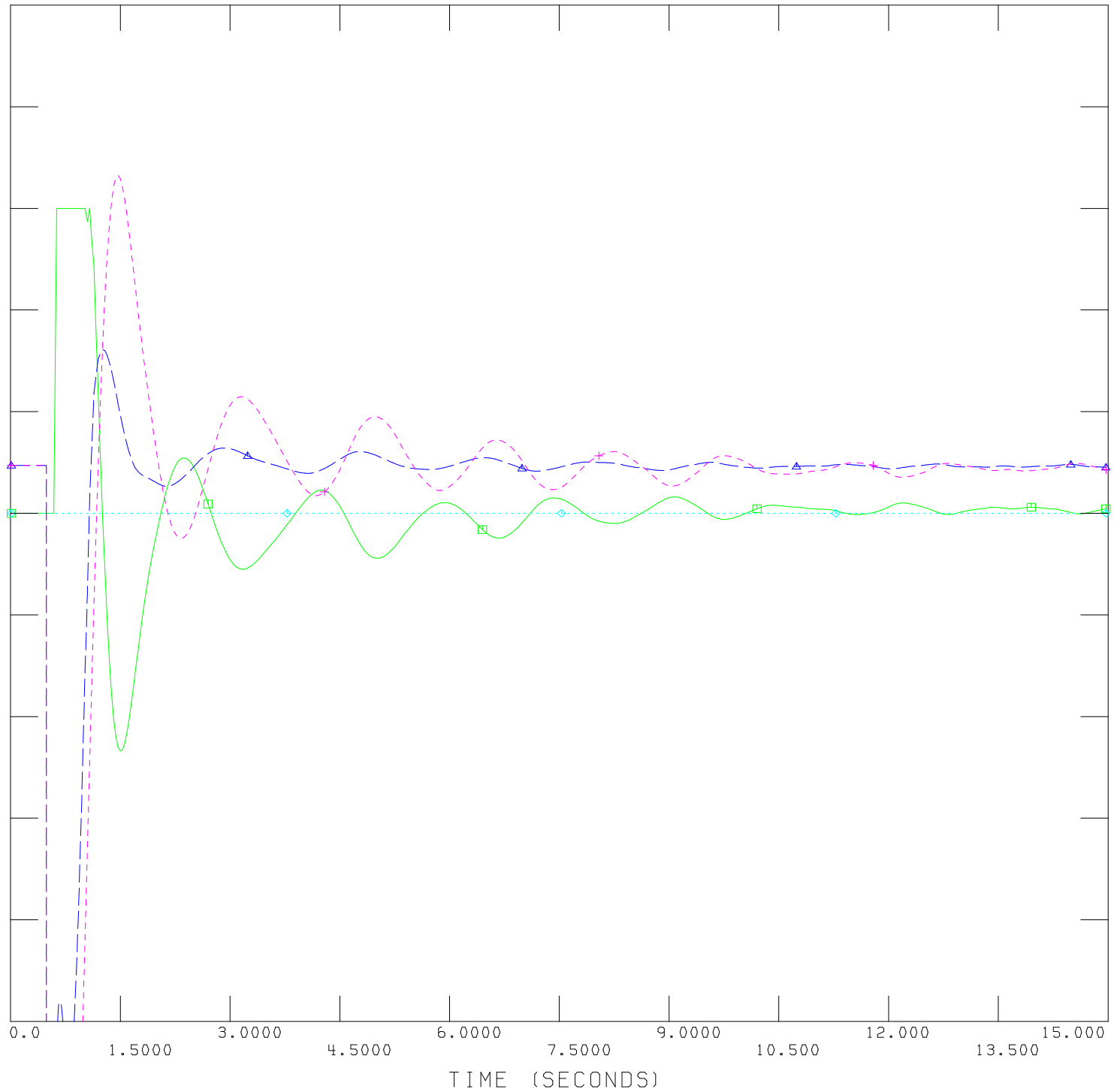

MON, DEC 17 2012 18:22

EXHIBIT-12

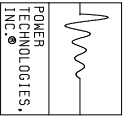

FAULT @ HYDR TRIP HYDR-HYDR_PP4

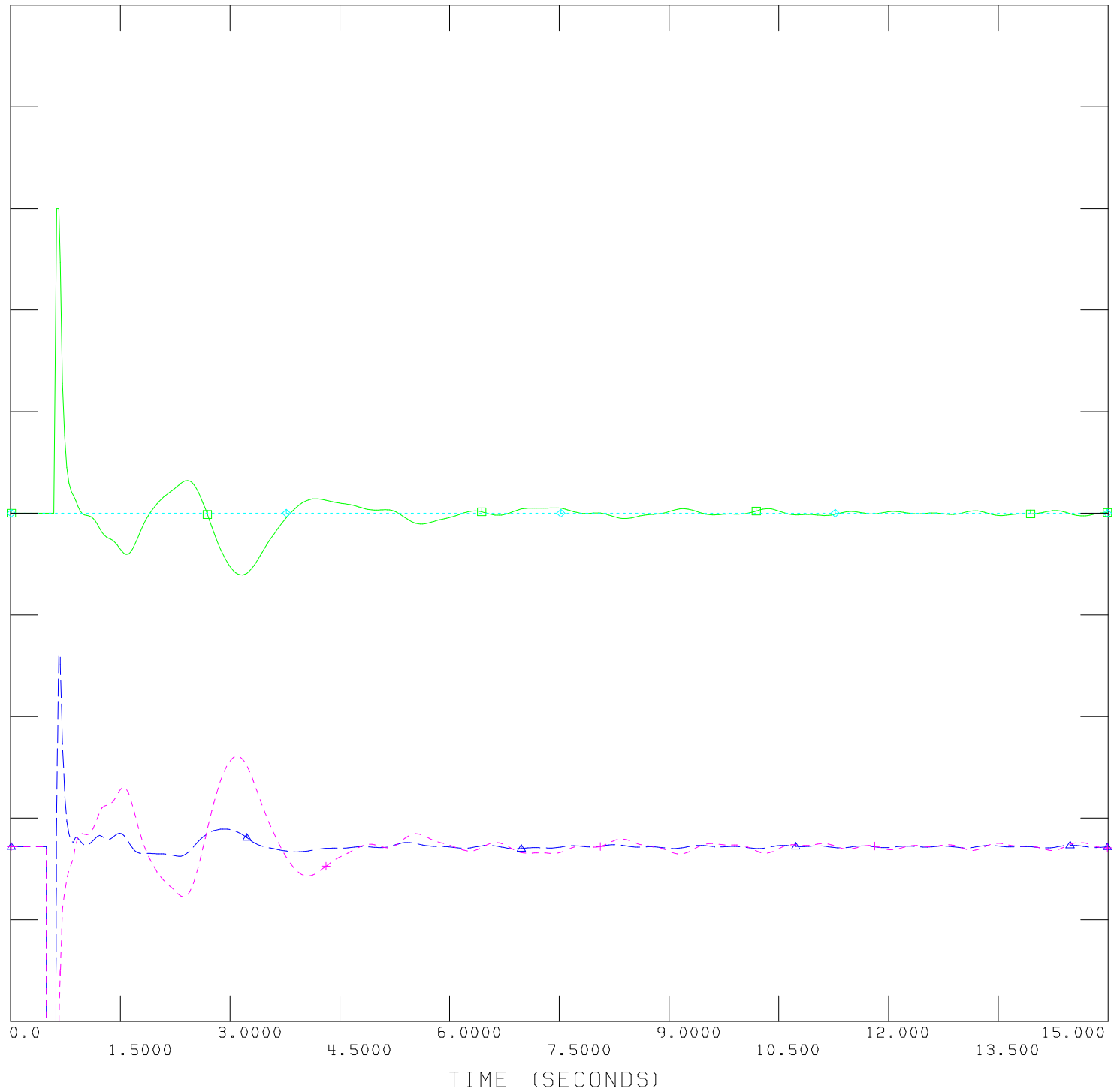

MON, DEC 17 2012 18:24

EXHIBIT-13

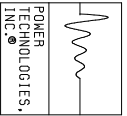

FAULT @ CUDP TRIP CUDP-CHTR

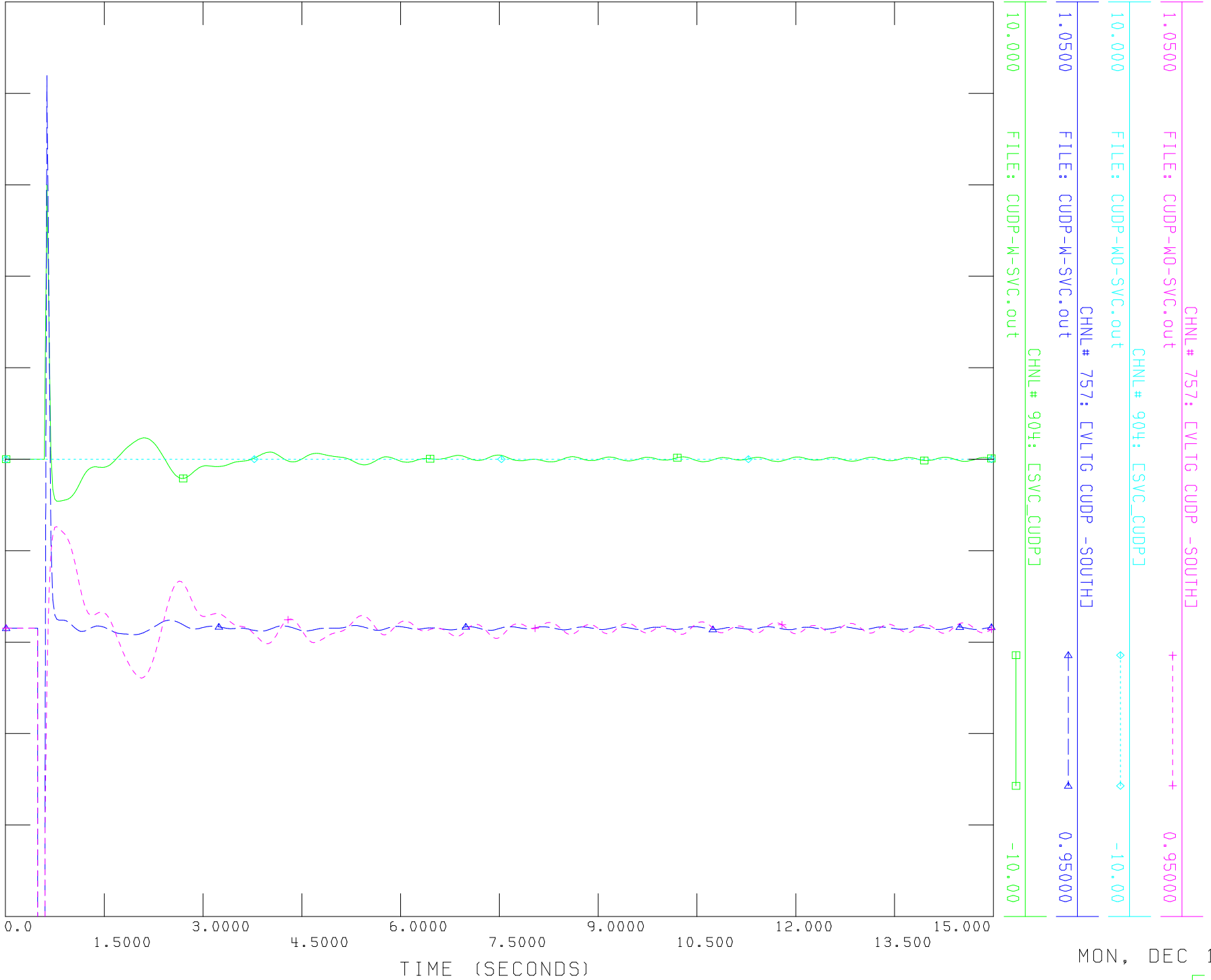

MON, DEC 17 2012 18:25

EXHIBIT-14

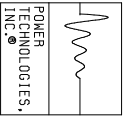

FAULT @ GOOTY TRIP GOOTY-SMNH

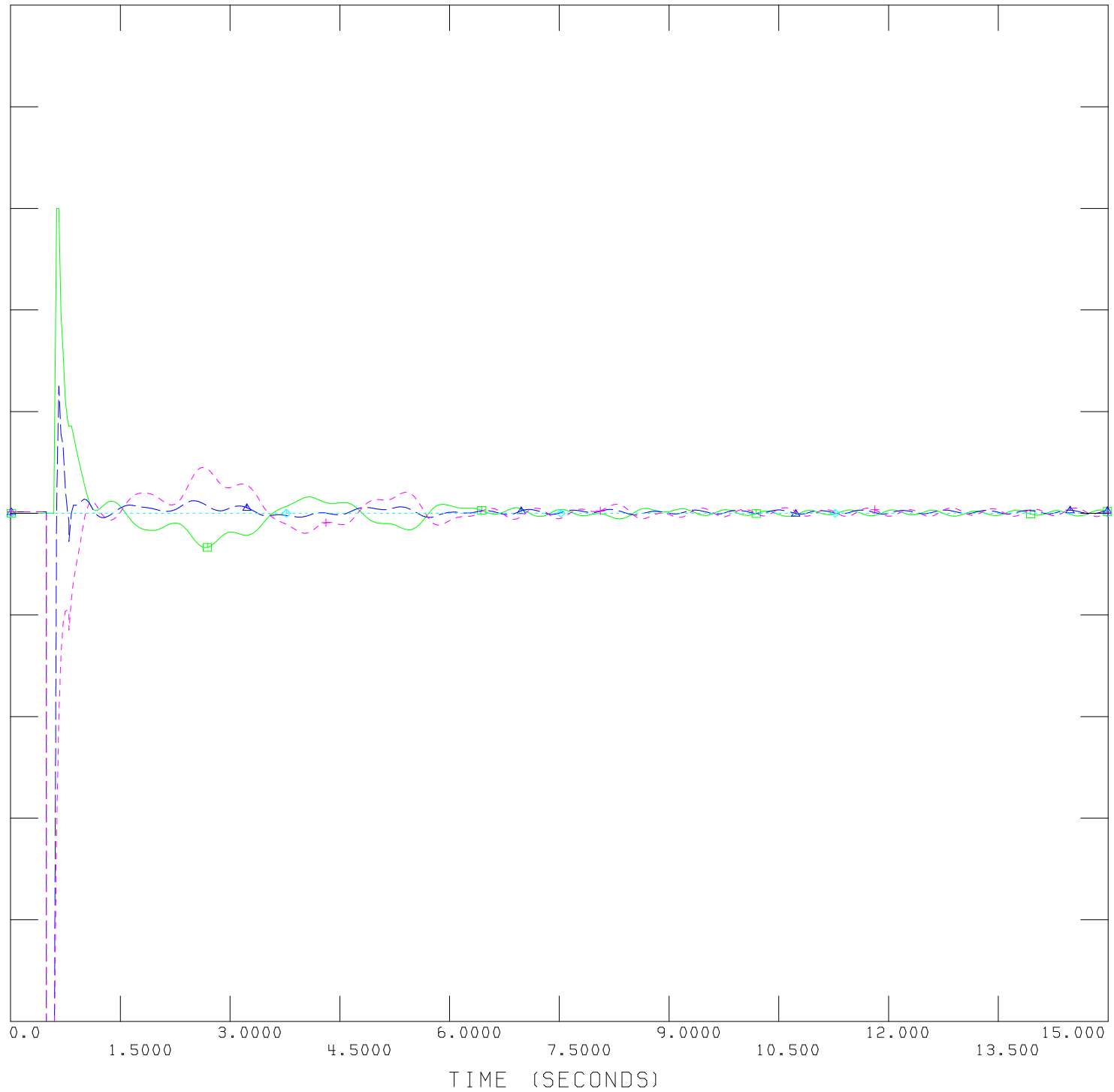

1.0500 CHNL# 758: [VLTG GOOT -SOUTH] +-----+ 0.950000
FILE: GOOTY-MO-SVC.out
10.000 CHNL# 905: [SVC_GOOT] △-----△ 0.950000
FILE: GOOTY-MO-SVC.out
1.0500 CHNL# 758: [VLTG GOOT -SOUTH] □-----□ -10.00
FILE: GOOTY-M-SVC.out
10.000 CHNL# 905: [SVC_GOOT] □-----□ -10.00
FILE: GOOTY-M-SVC.out



FAULT @ HOSUR TRIP HOSUR-SALEM

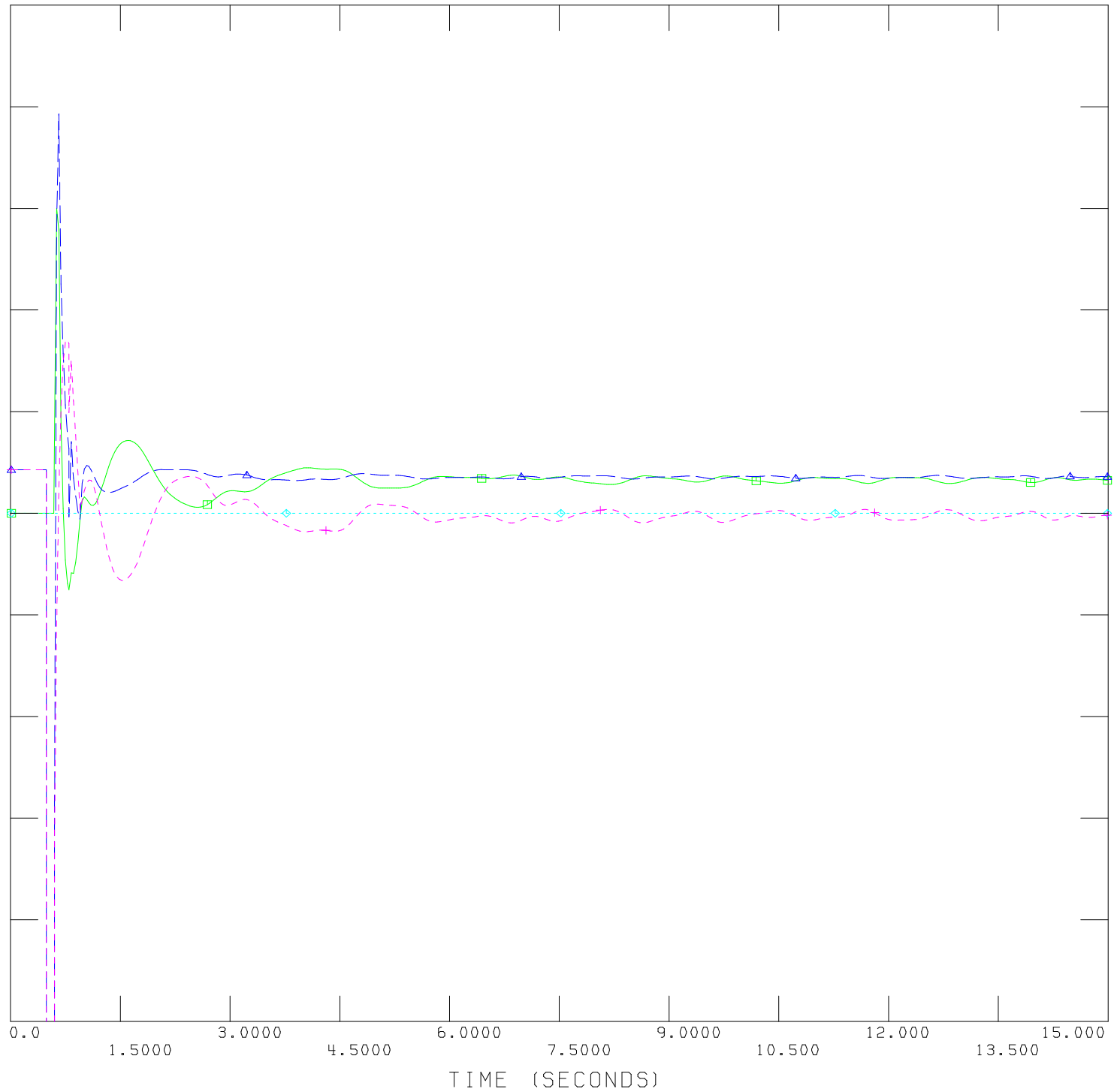

1.0500 CHNL# 838: CVLTG HOSUR4 -SOUTH] +-----+ 0.950000
FILE: HOSR-W0-SVC.out
10.000 CHNL# 910: [SVC_HYOSUR]
FILE: HOSR-W0-SVC.out
1.0500 CHNL# 838: CVLTG HOSUR4 -SOUTH] <-----< 0.950000
FILE: HOSR-W-SVC.out
10.000 CHNL# 910: [SVC_HYOSUR] <-----< -10.00
FILE: HOSR-W-SVC.out

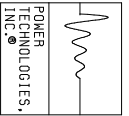

FAULT @ TRIC TRIP TRIC-NEYV

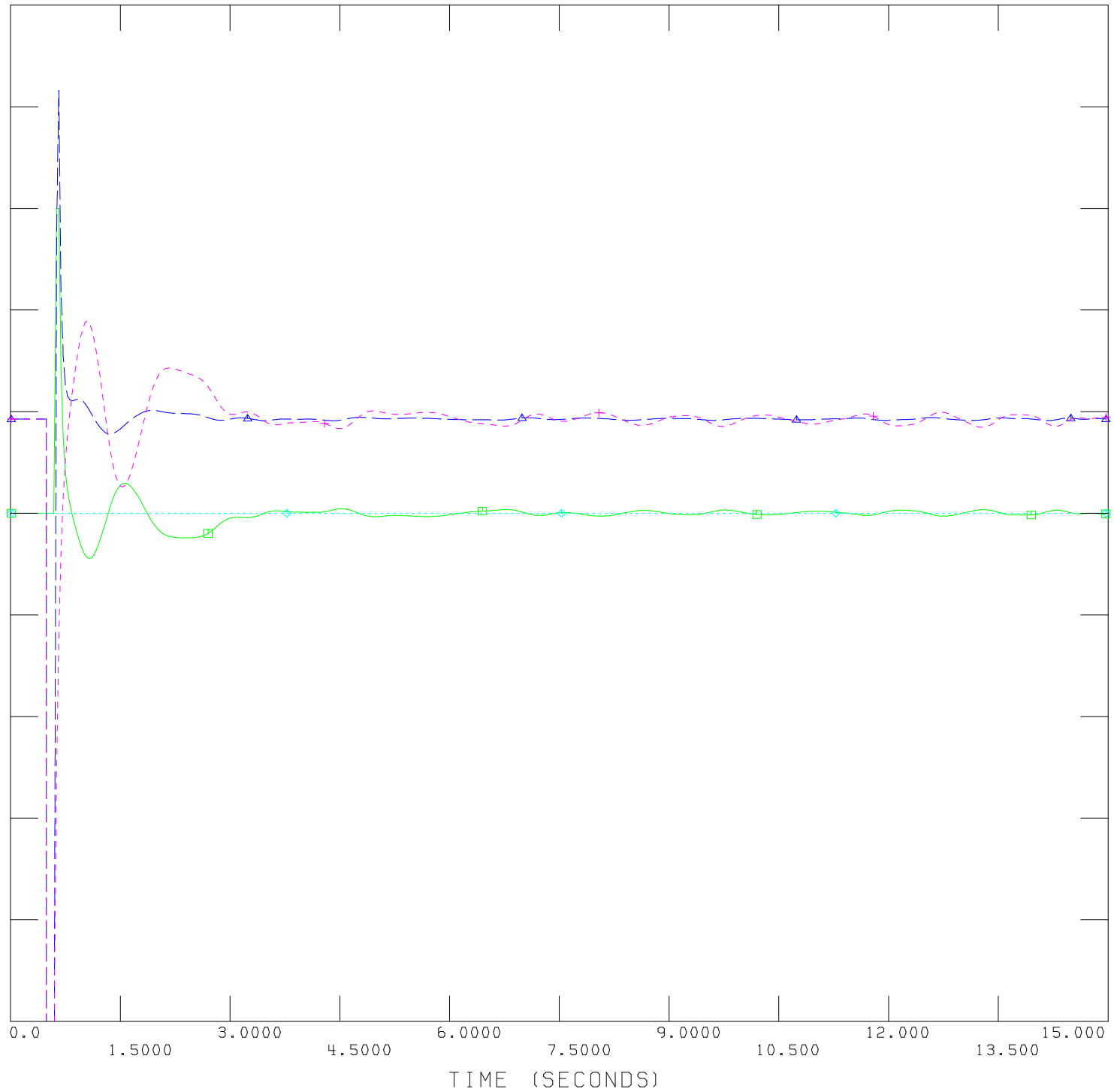

MON, DEC 17 2012 18:36

EXHIBIT-18

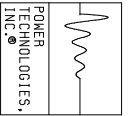

FAULT @ SMNH TRIP SMNH-HOSUR

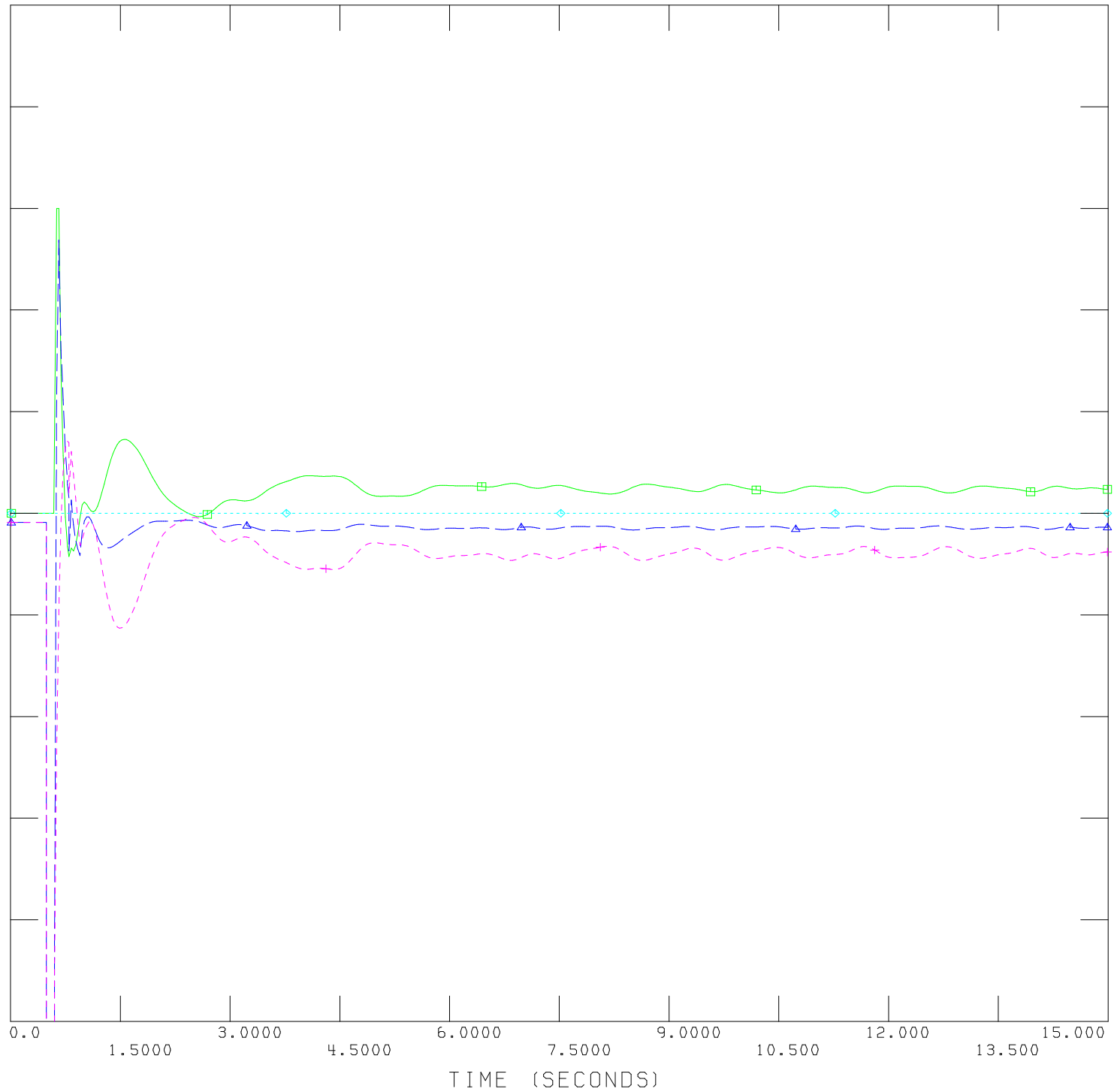

1.0500 FILE: SMNH-W0-SVC.out CHNL # 801: [CVLTG SMNH -SOUTH] +-----+ 0.950000
10.000 FILE: SMNH-W0-SVC.out CHNL # 906: [SVC_SMNH]◇ -10.00
1.0500 FILE: SMNH-W-SVC.out CHNL # 801: [CVLTG SMNH -SOUTH] -----△ 0.950000
10.000 FILE: SMNH-W-SVC.out CHNL # 906: [SVC_SMNH] -----□ -10.00

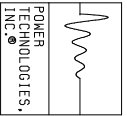

FAULT @ ROURKELA TRIP 400KV ROURKELA-RAIGARH 1

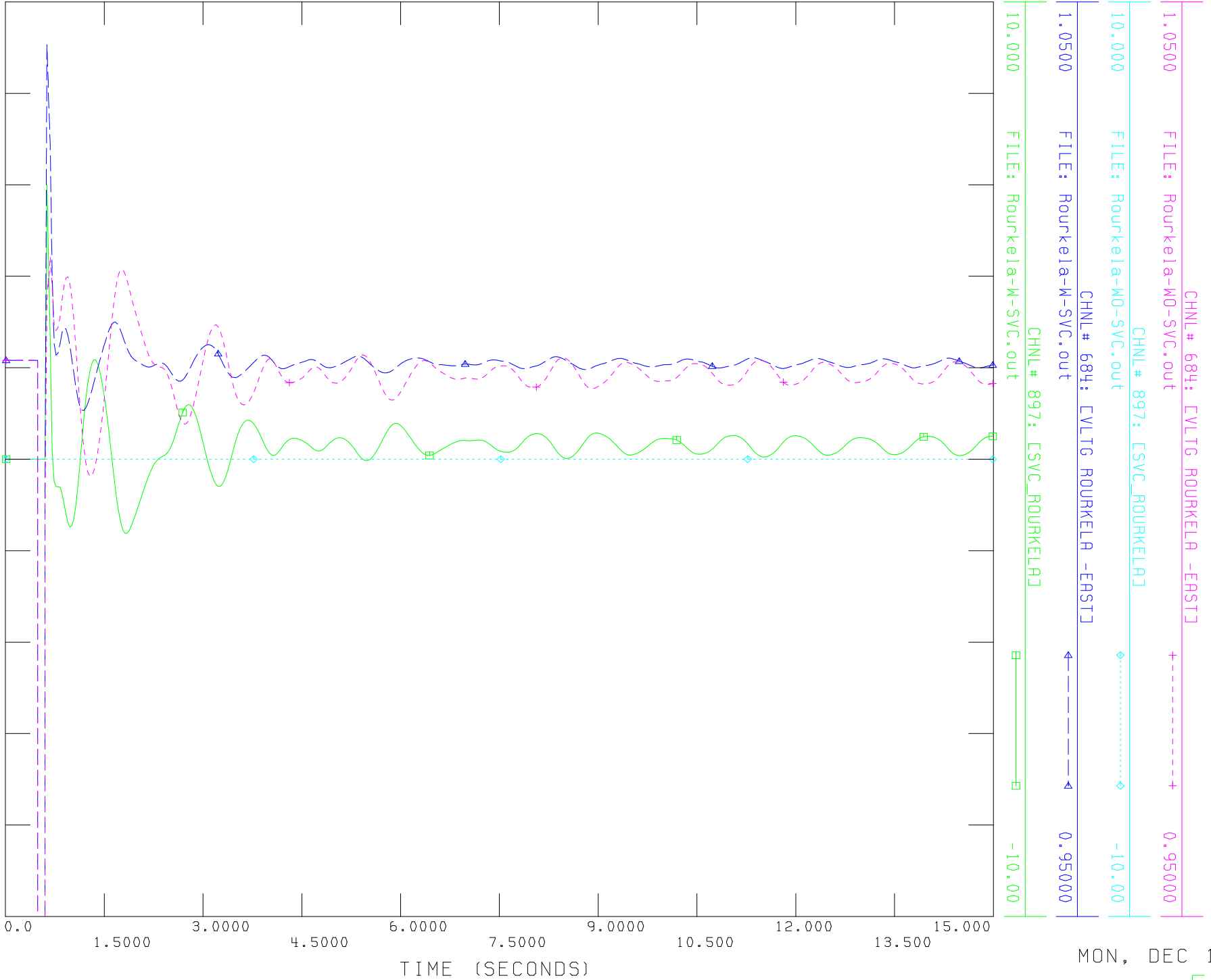

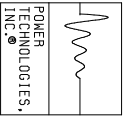

FAULT @ MUZAFFARPUR TRIP MUZAFFARPUR-CORAKHPUR 1

MON, DEC 17 2012 18:39
EXHIBIT-21

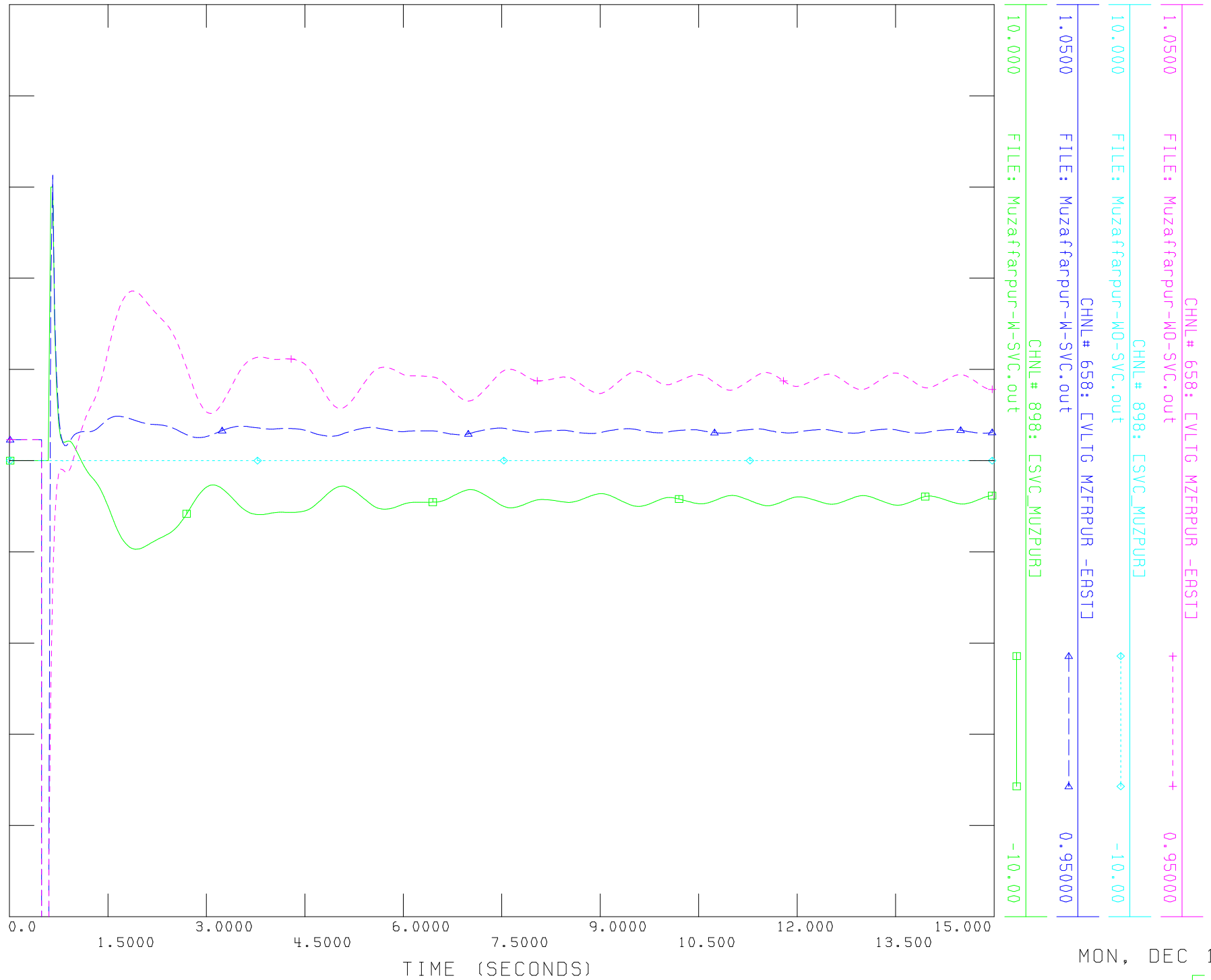

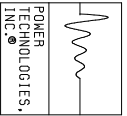

FAULT @ RANCHI (NEW) TRIP 400KV RANCHI-DHARAM JAYGARH 1

MON, DEC 17 2012 18:59
EXHBIT-22

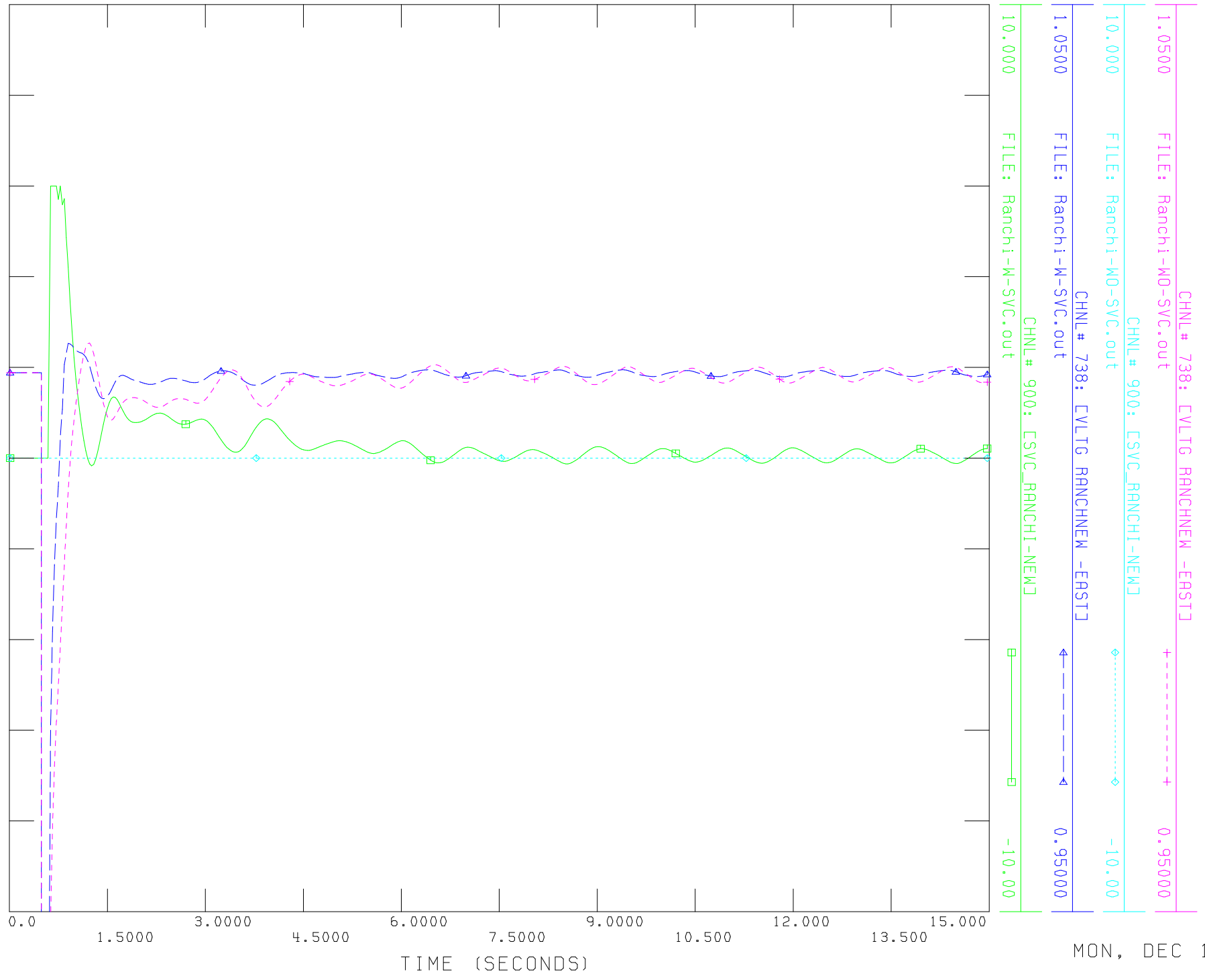

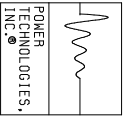

FAULT @ GARYA TRIP GARYA-BALLIA 1

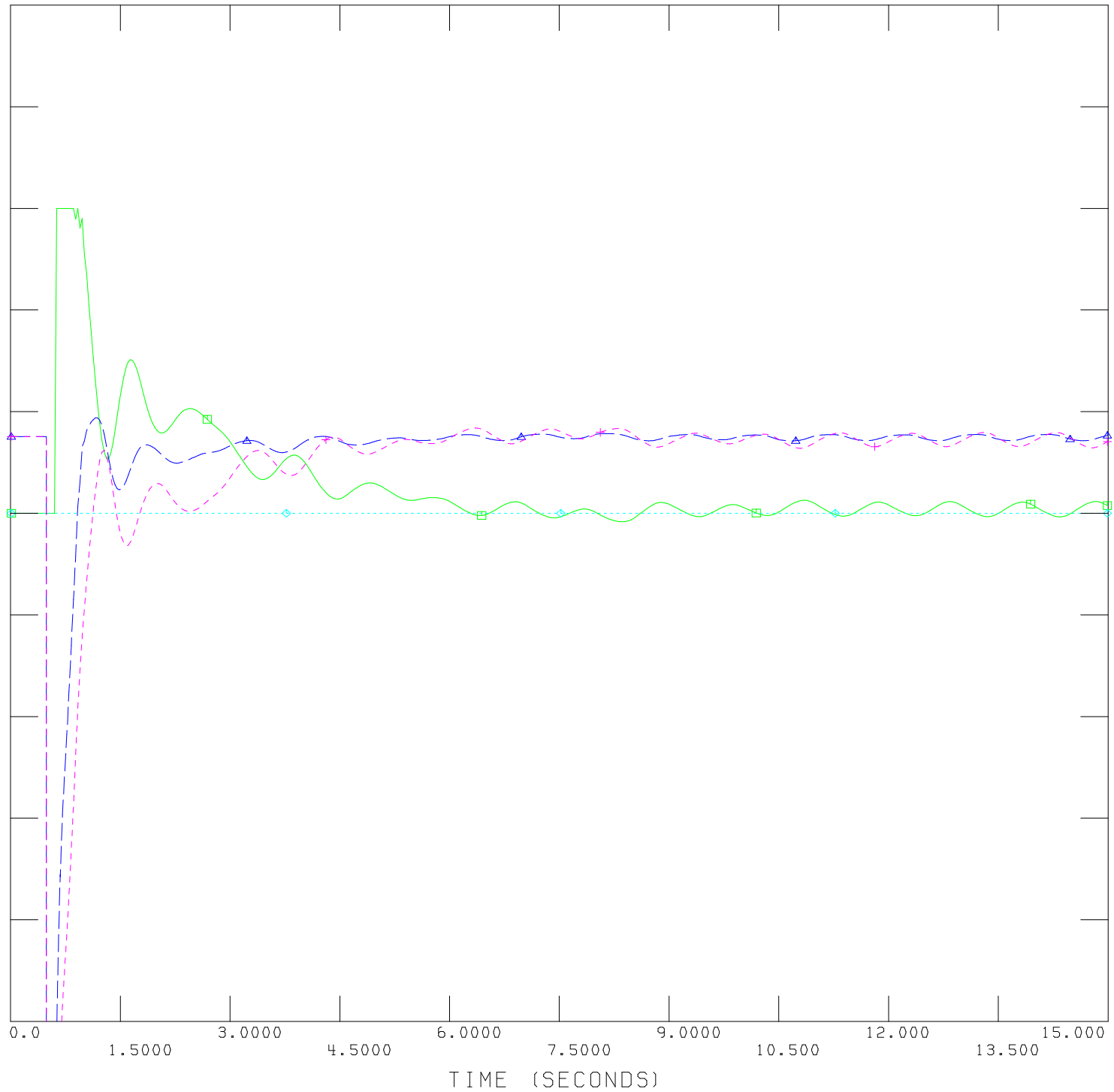

MON, DEC 17 2012 19:16

EXHIBIT-23

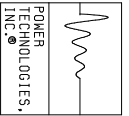

FAULT @ KISHENGANJ TRIP KISHENGANJ-SILIGURI 1

MON, DEC 17 2012 18:42
EXHIBIT-24

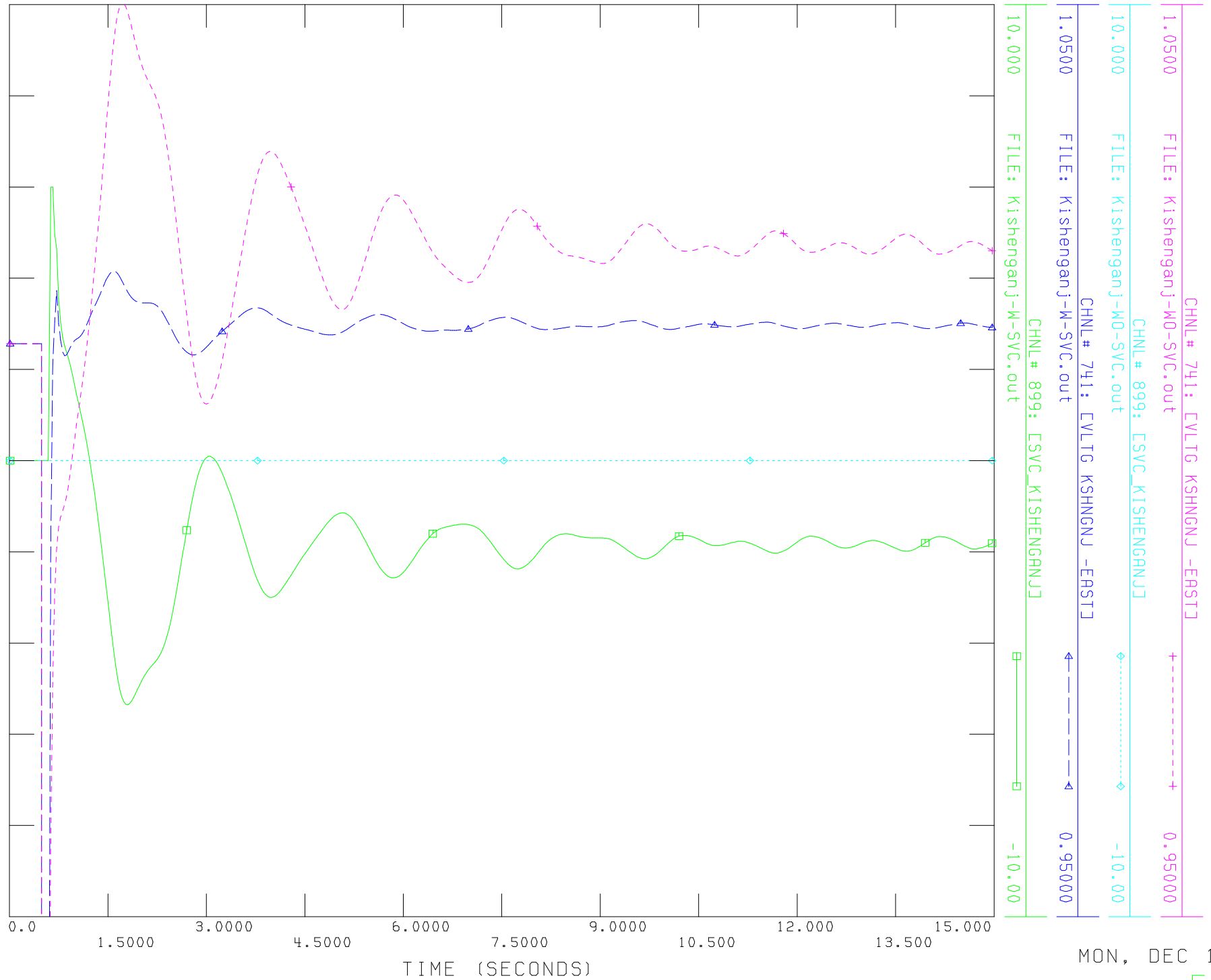

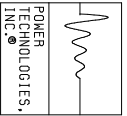

FILE: V:\Ani1\svc\India\KANP_svc.out
CHNL # 890: [SVC_NMANPOH]

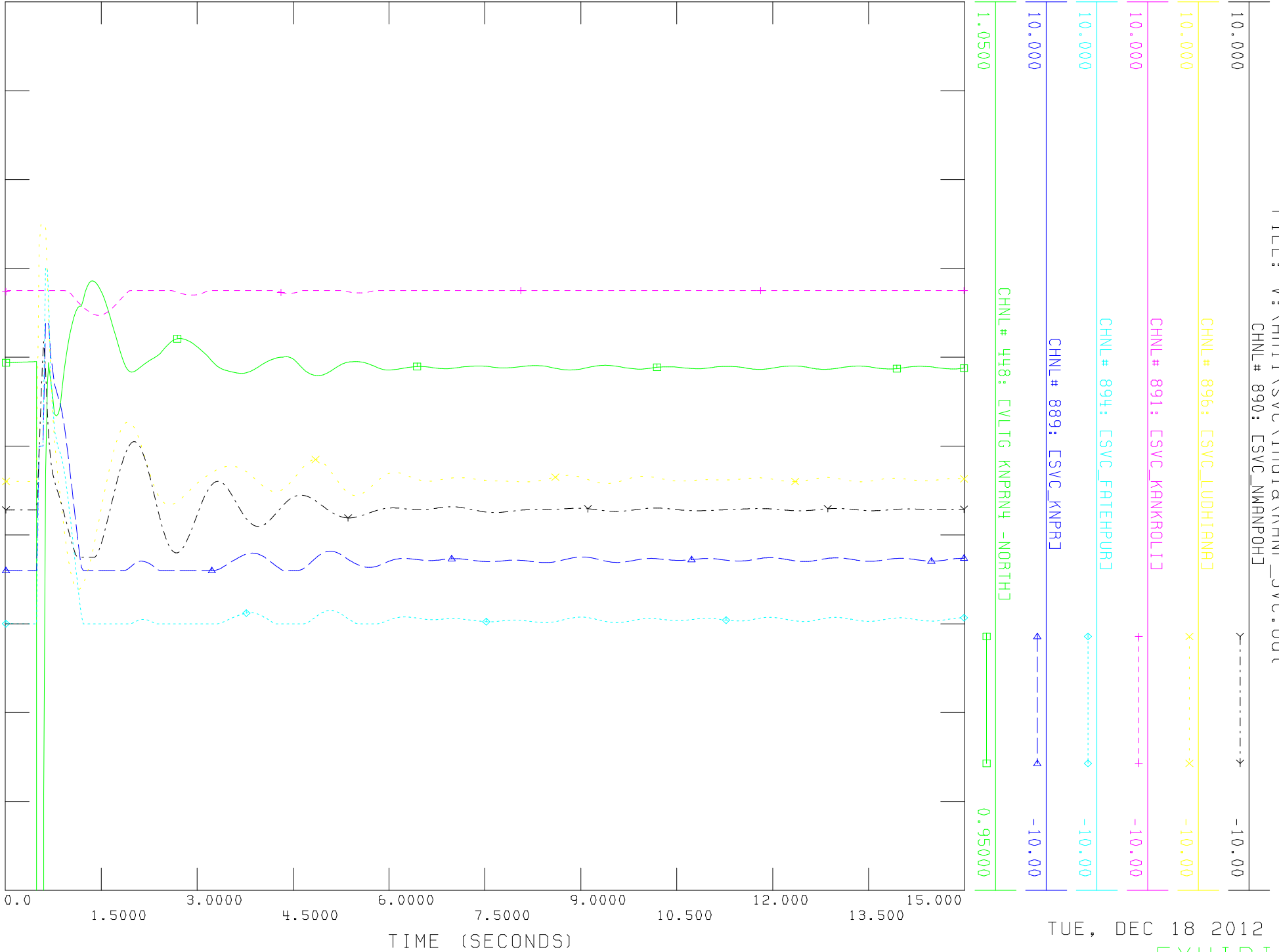

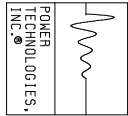

FILE: V:\Ani1\svc\India\MNP_SVC.out

CHNL # 894: [SVC_FATEHPUR]

10.000 -10.00

10.000 -10.00

10.000 -10.00

10.000 -10.00

10.000 -10.00

1.0500 0.95000

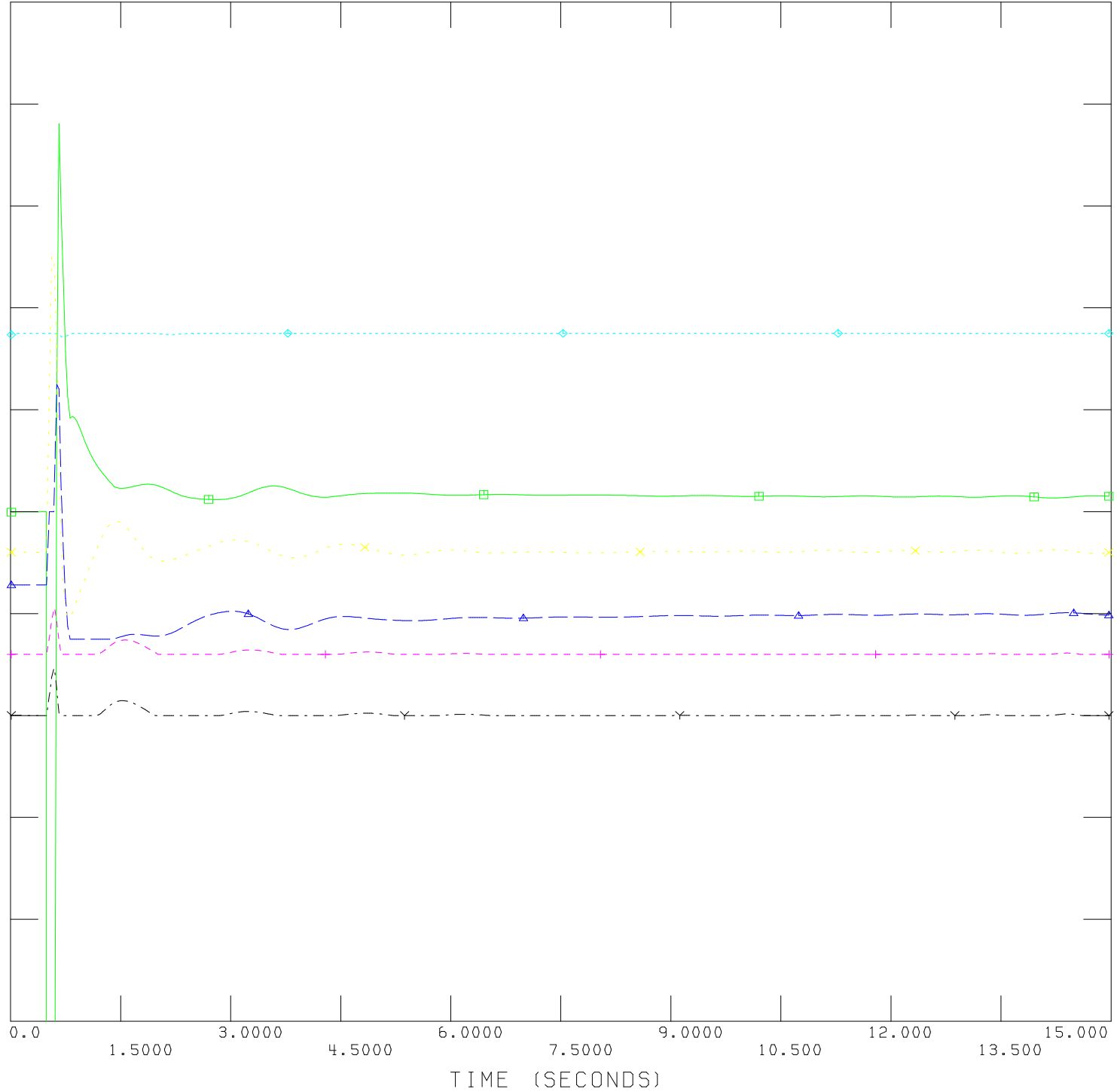

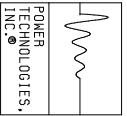

FAULT @ LUDHIANA TRIP LUDHIANA-PATIALA

FILE: V:\Ani1\svc\India\LUDH_SVC.out
CHNL# 894: [SVC_FATEHPUR]

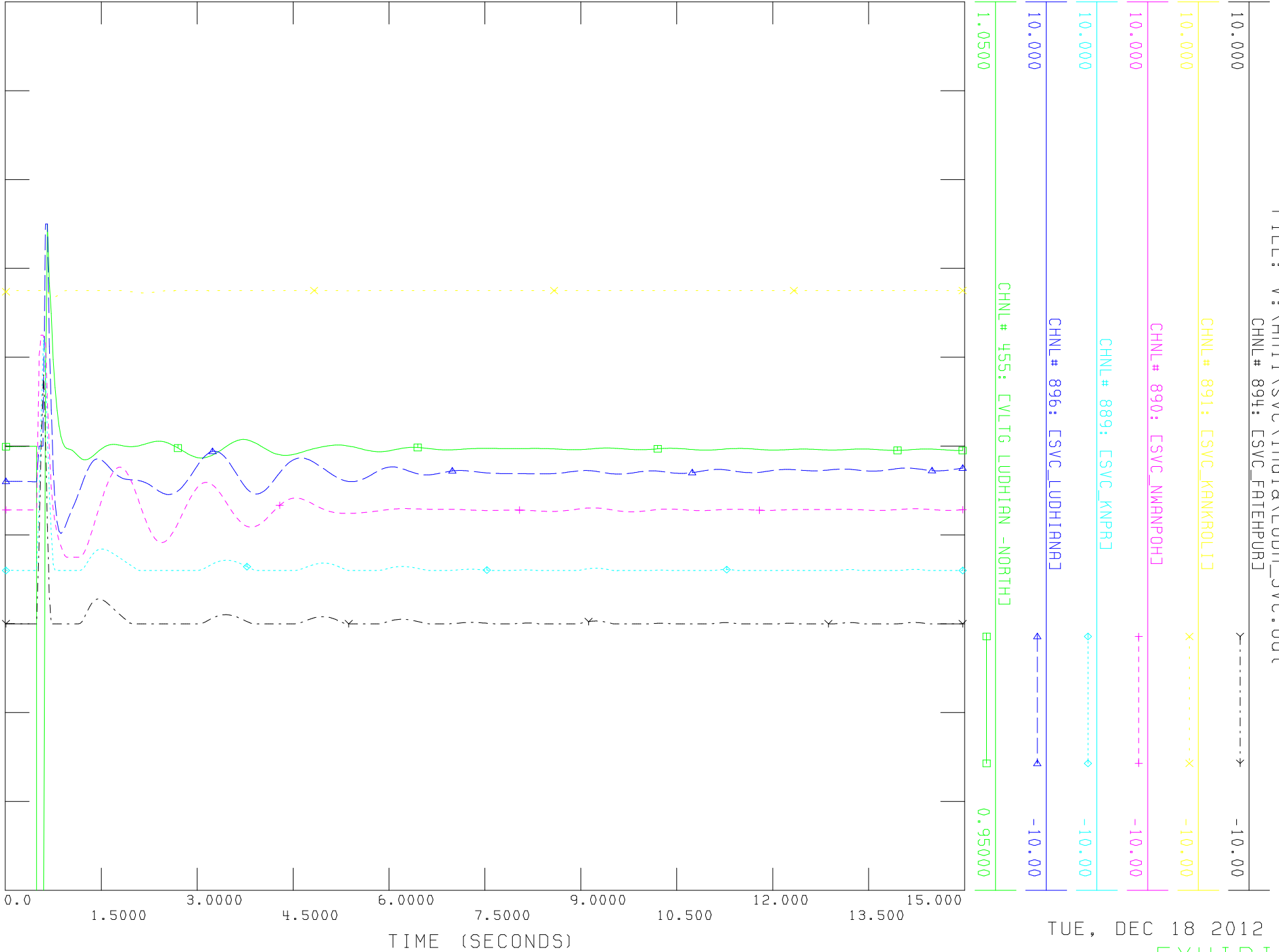

TUE, DEC 18 2012 19:07

EXHIBIT-27

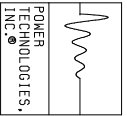

FILE: V:\Ani1\svc\India\KANK_svc.out
CHNL# 894: [SVC_FATEHPUR]

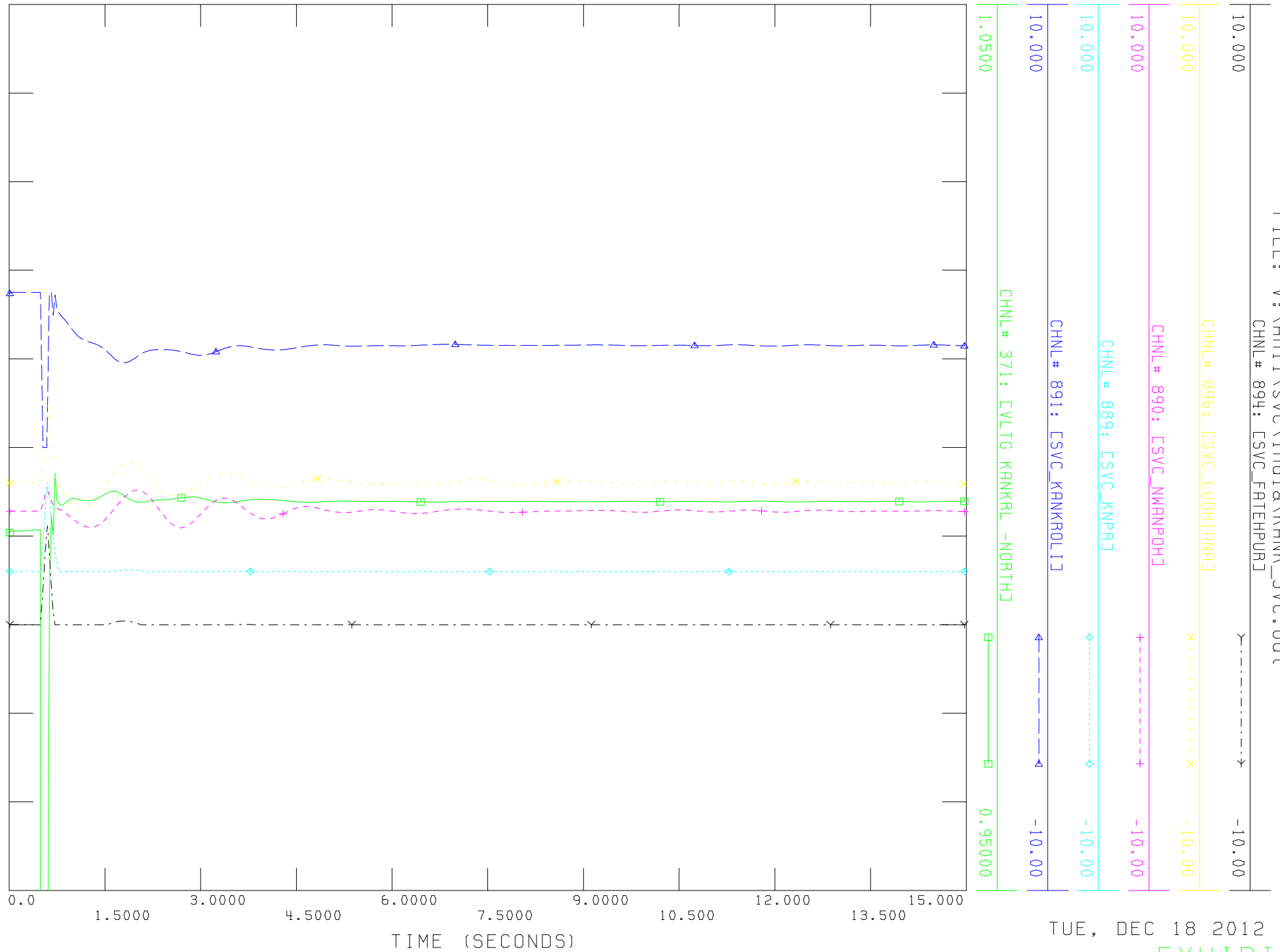

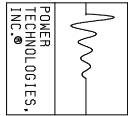

FAULT @ FATEHPUR TRIP FATEHPUR-MAINPURI

FILE: V:\Ani1\svc\India\FATE_SVC.out

CHNL# 900: [SVC_RANCHI-NEWJ]

15.000

15.000

0.0

15.000

10.000

1.0500

-10.00

-10.00

-5.000

-10.00

-10.00

0.95000

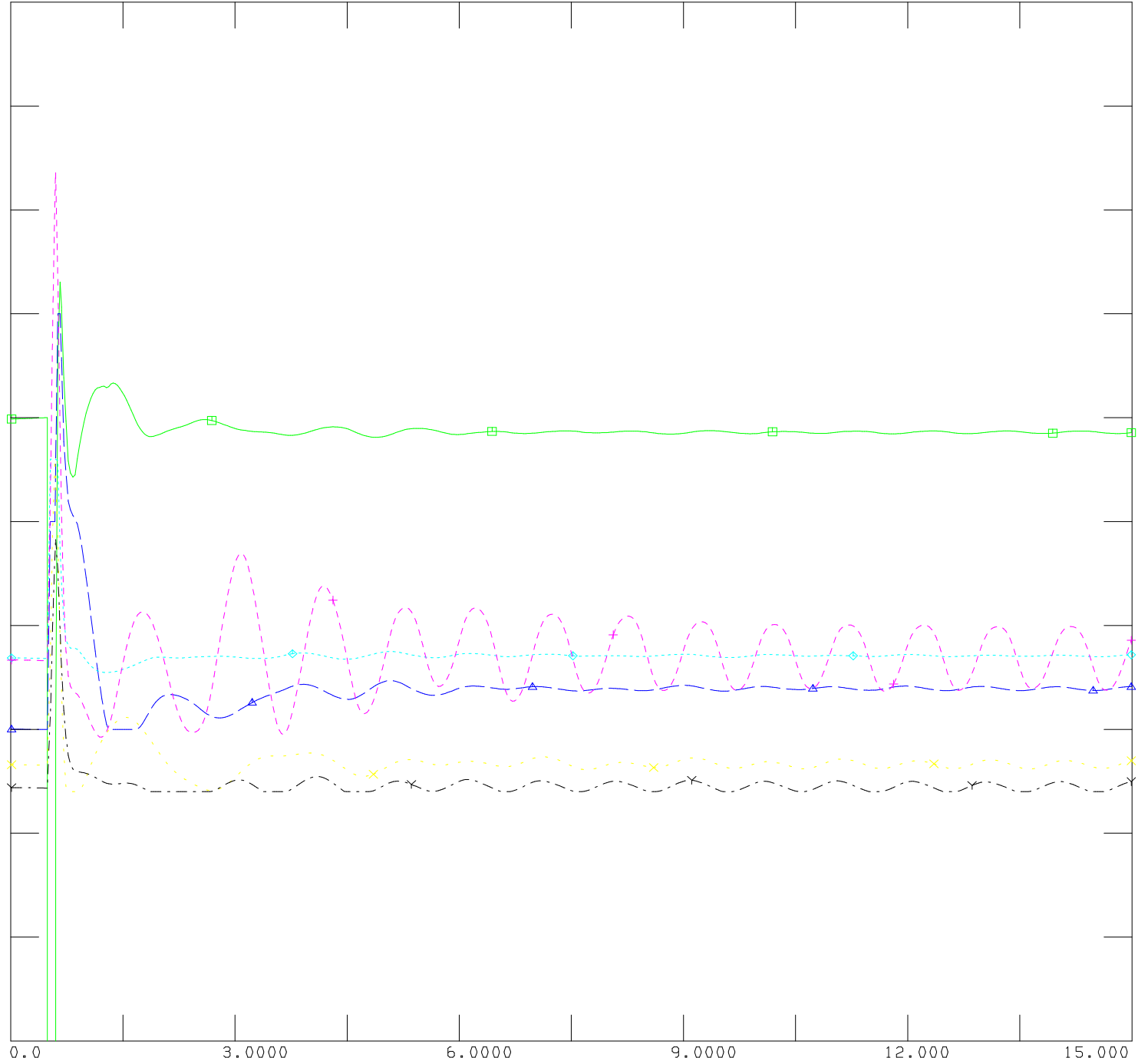

0.0 1.5000 3.0000 4.5000 6.0000 7.5000 9.0000 10.500 12.000 13.500 15.000

TIME (SECONDS)

TUE, DEC 18 2012 11:05

EXHIBIT-29

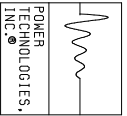

FAULT @ SOLAPUR TRIP SOLAPUR-RAICHUR #2

FILE: V:\Ani1\svc\India\SLPR_svc.out
CHNL # 886: [SVC_GMLR]

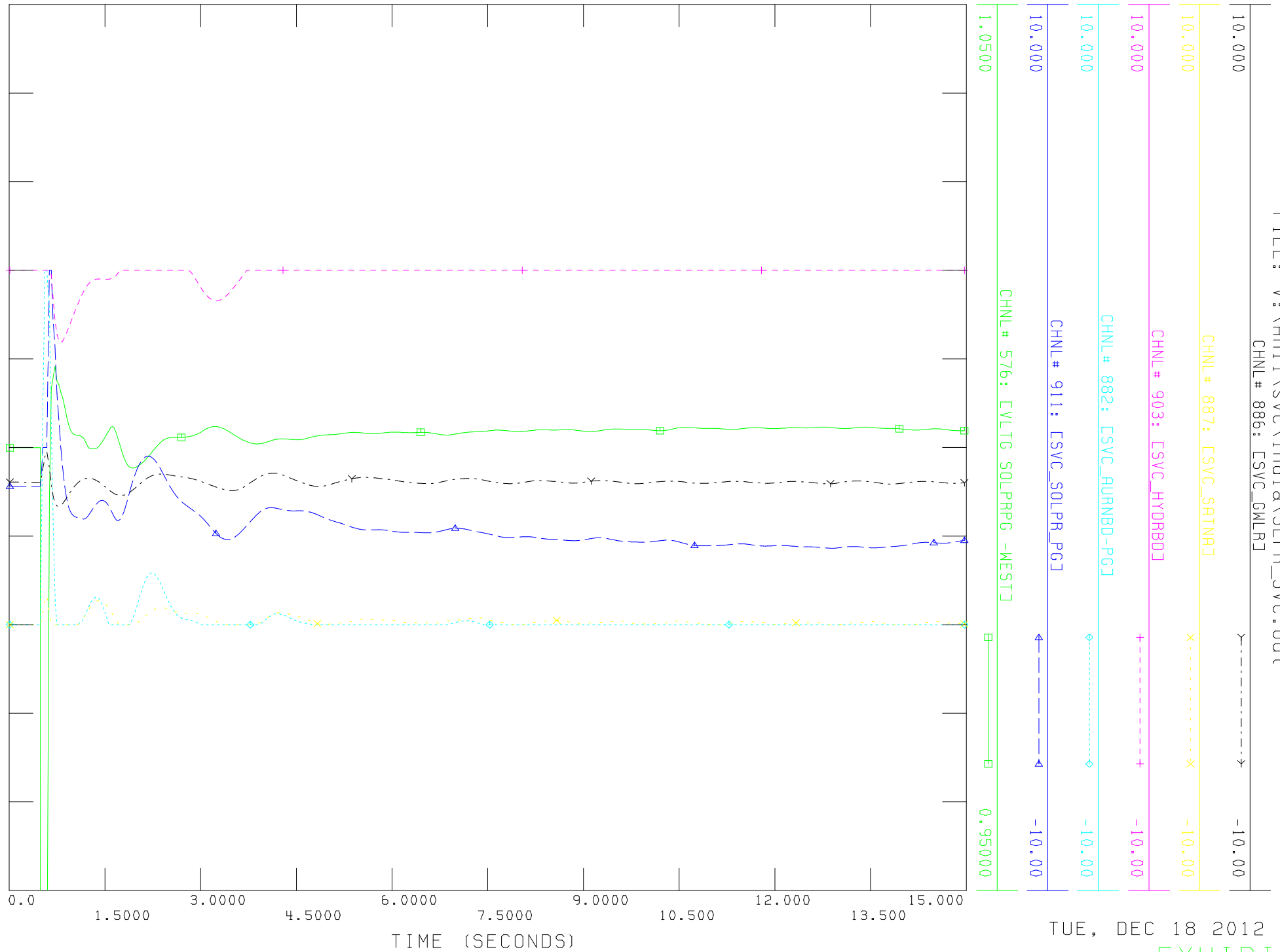

TUE, DEC 18 2012 12:22

EXHIBIT-30

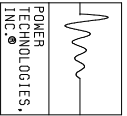

FILE: V:\An11\svc\India\Gwalior_svc.out
CHNL# 897: [SVC_ROURKELA1]

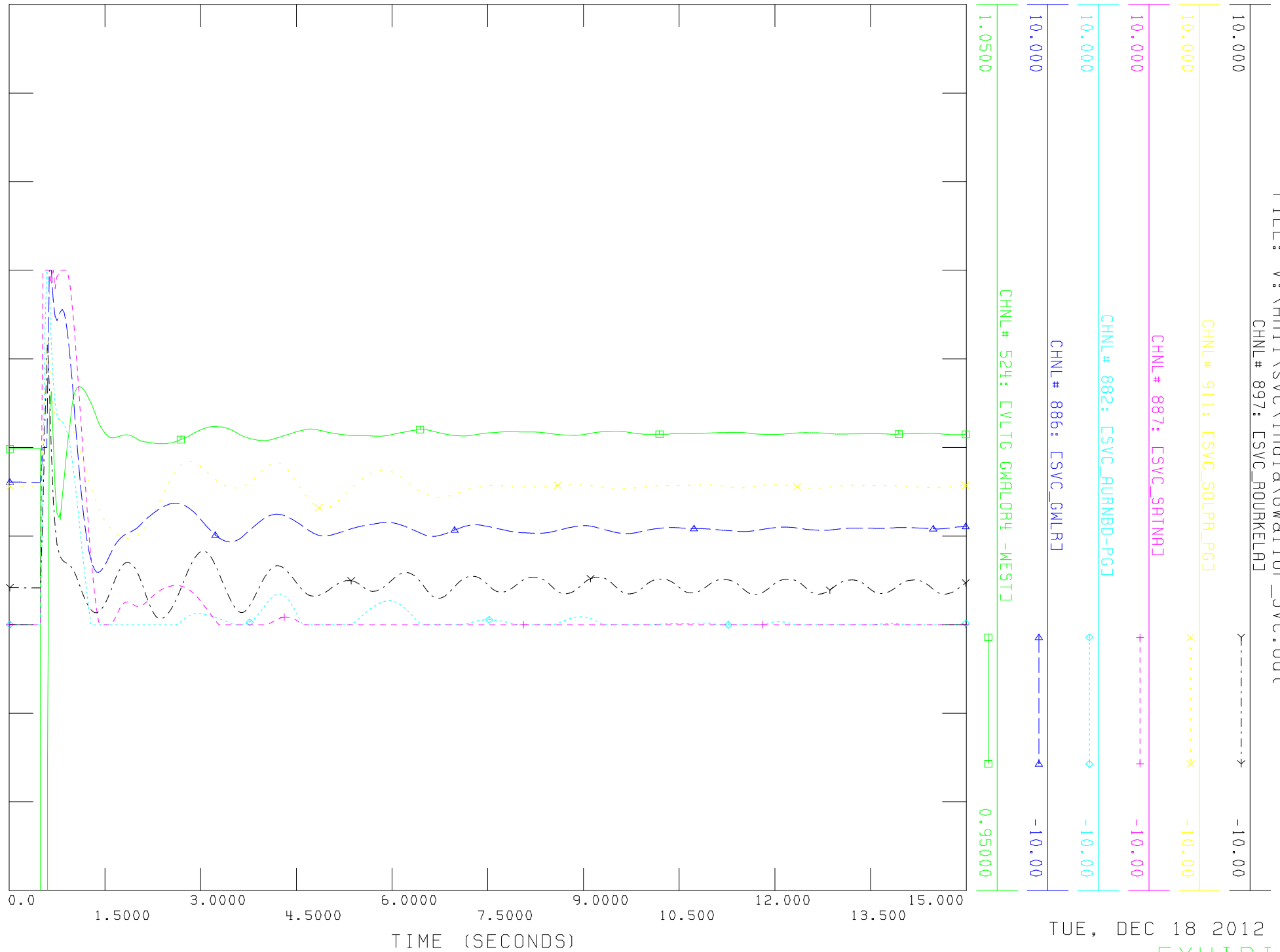

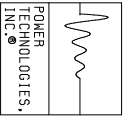

FILE: V:\Ani1\svc\India\ARBD_svc.out
CHNL# 903: [SVC_HYDRBD]

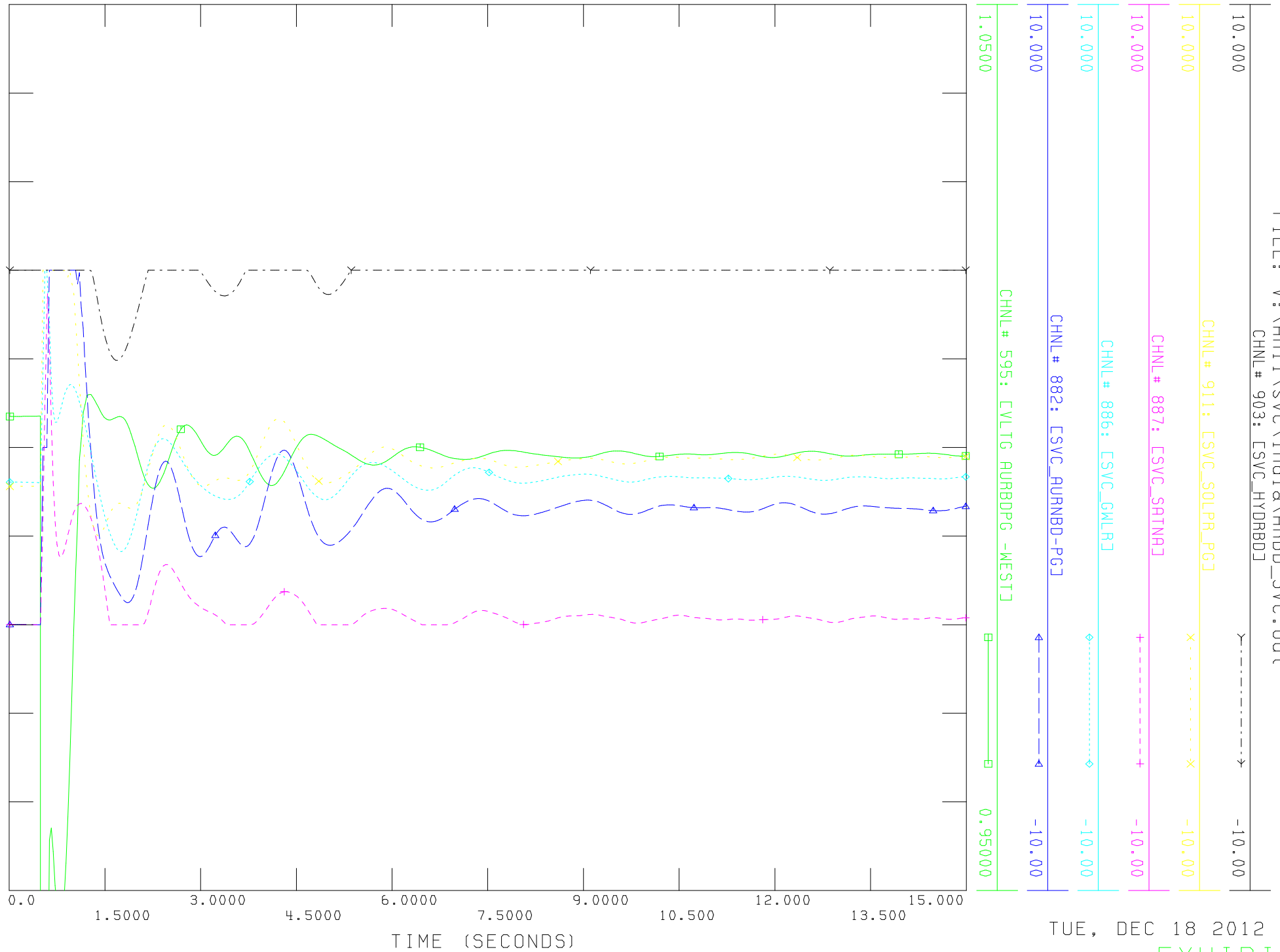

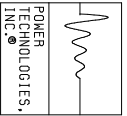

FILE: V:\Ani1\svc\India\Satna_svc.out
CHNL # 882: [SV_C_AURNBD-F6J]

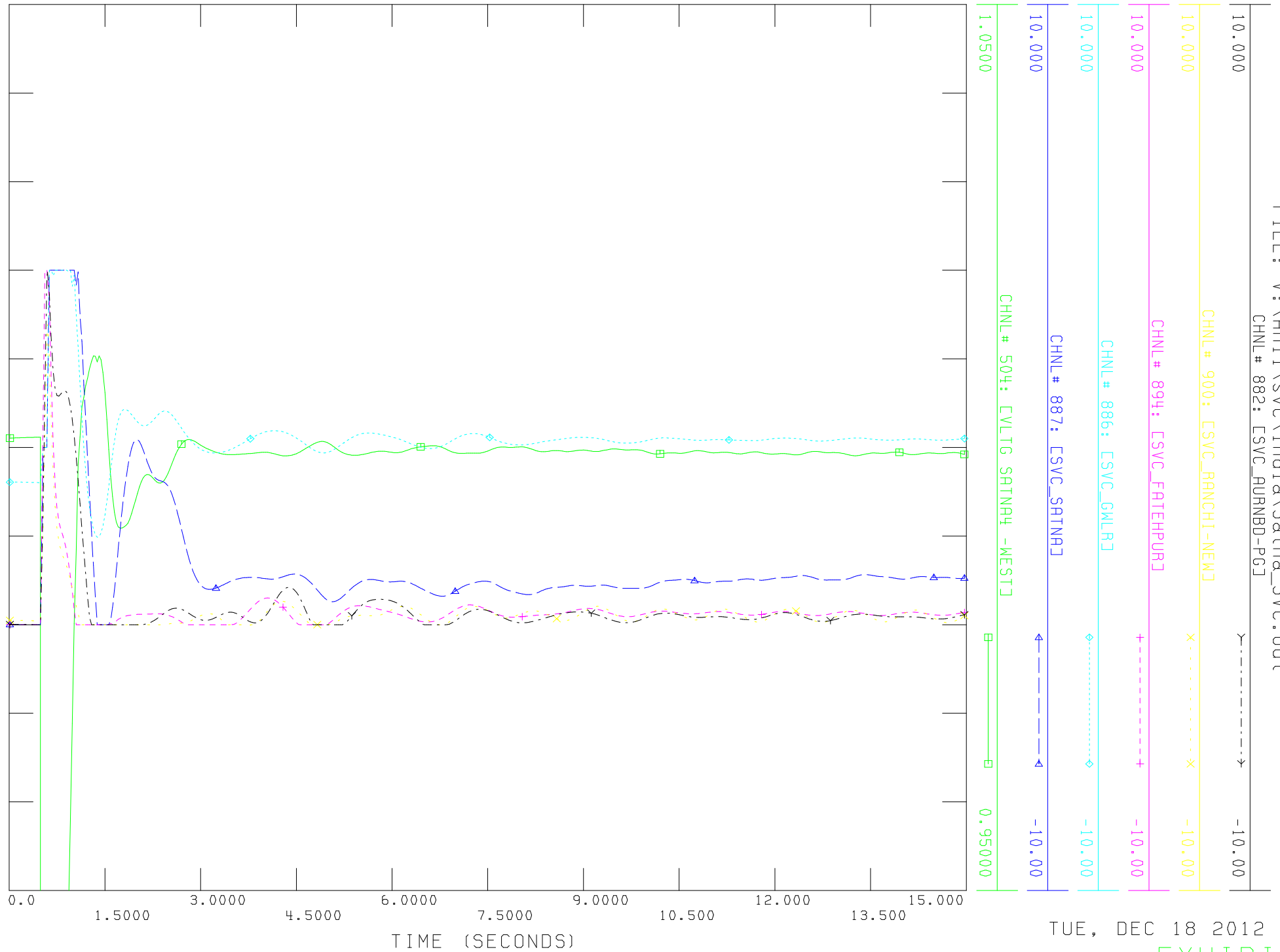

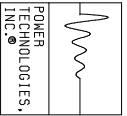

FILE: V:\An11\svc\India\HYDR_svc.out

CHNL# 900: [SVCT_RANCHI-NEWJ]

-10.00

CHNL# 911: [SVCT_SOLPR_PGJ]

-10.00

CHNL# 908: [SVCT_TRICJ]

-10.00

CHNL# 907: [SVCT_UDMPJ]

-10.00

CHNL# 903: [SVCT_HYDRBDJ]

-10.00

CHNL# 752: [VLTG HYDR -SOUTHJ]

0.95000

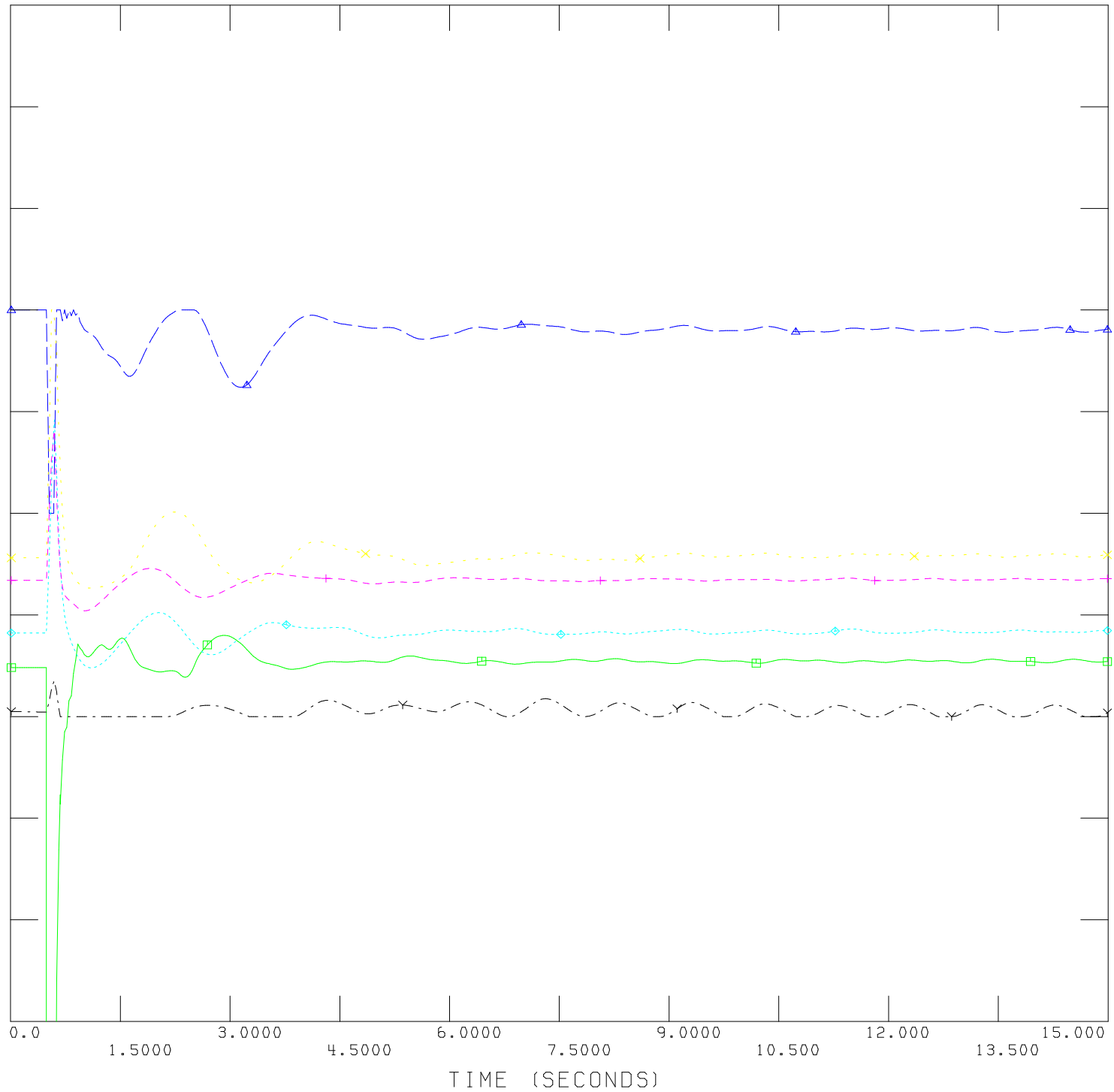

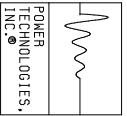

FILE: V:\An11\svc\India\UDMP_svc.out

CHNL# 900: [SVCT_RANCHI-NEW]

-10.00

CHNL# 911: [SVCT_SOLPR_PG]

-10.00

CHNL# 903: [SVCT_HYDRBD]

-10.00

CHNL# 908: [SVCT_TRIC]

-10.00

CHNL# 907: [SVCT_UDMP]

-10.00

CHNL# 837: [VLTG_UDMP -SOUTH]

0.95000

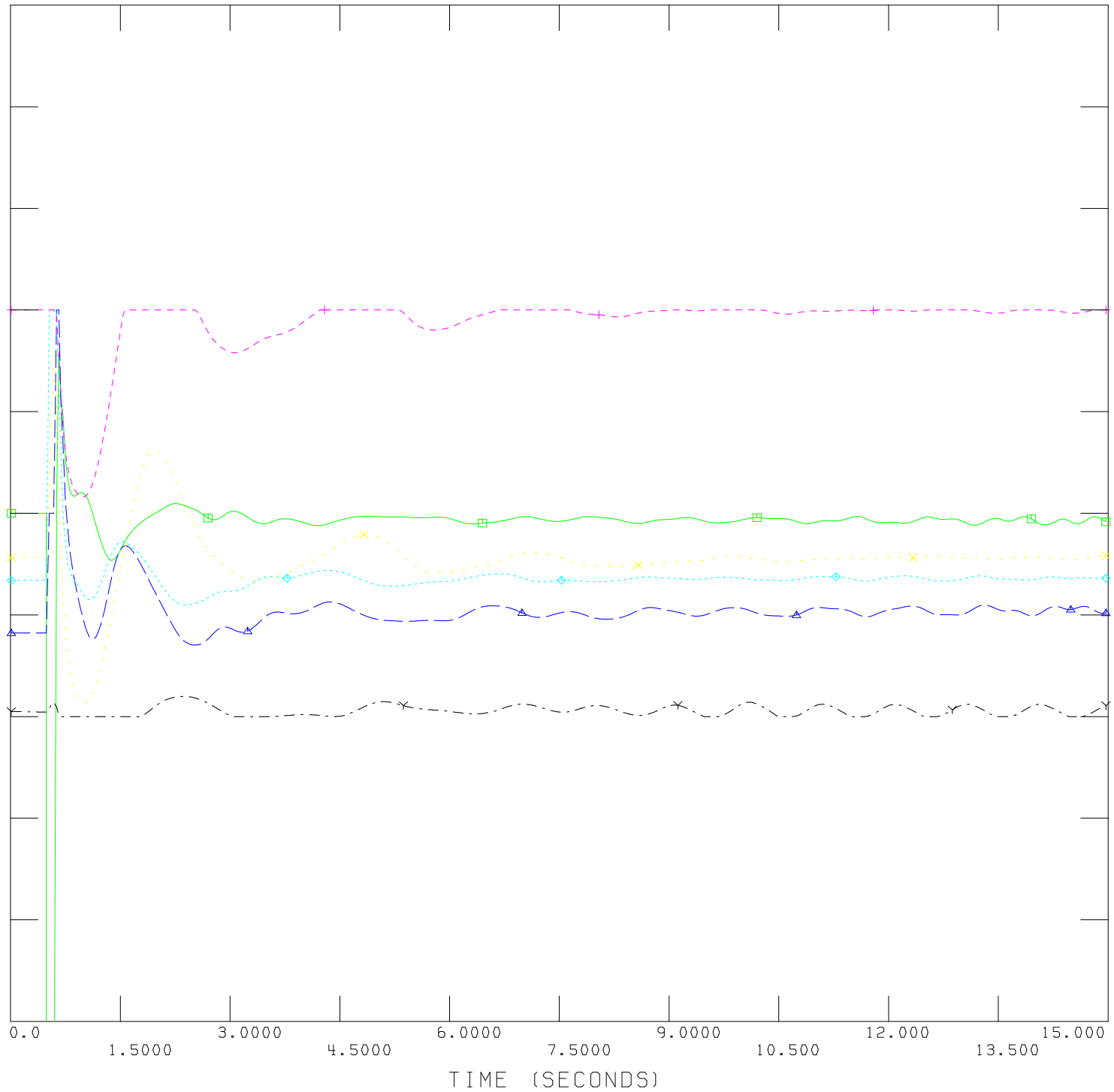

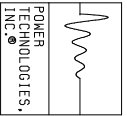

FAULT @ TRIC TRIP TRIC-NEYV

FILE: V:\An1\svc\India\TRIC_SVC.out
CHNL # 886: [SVC_GMLR]

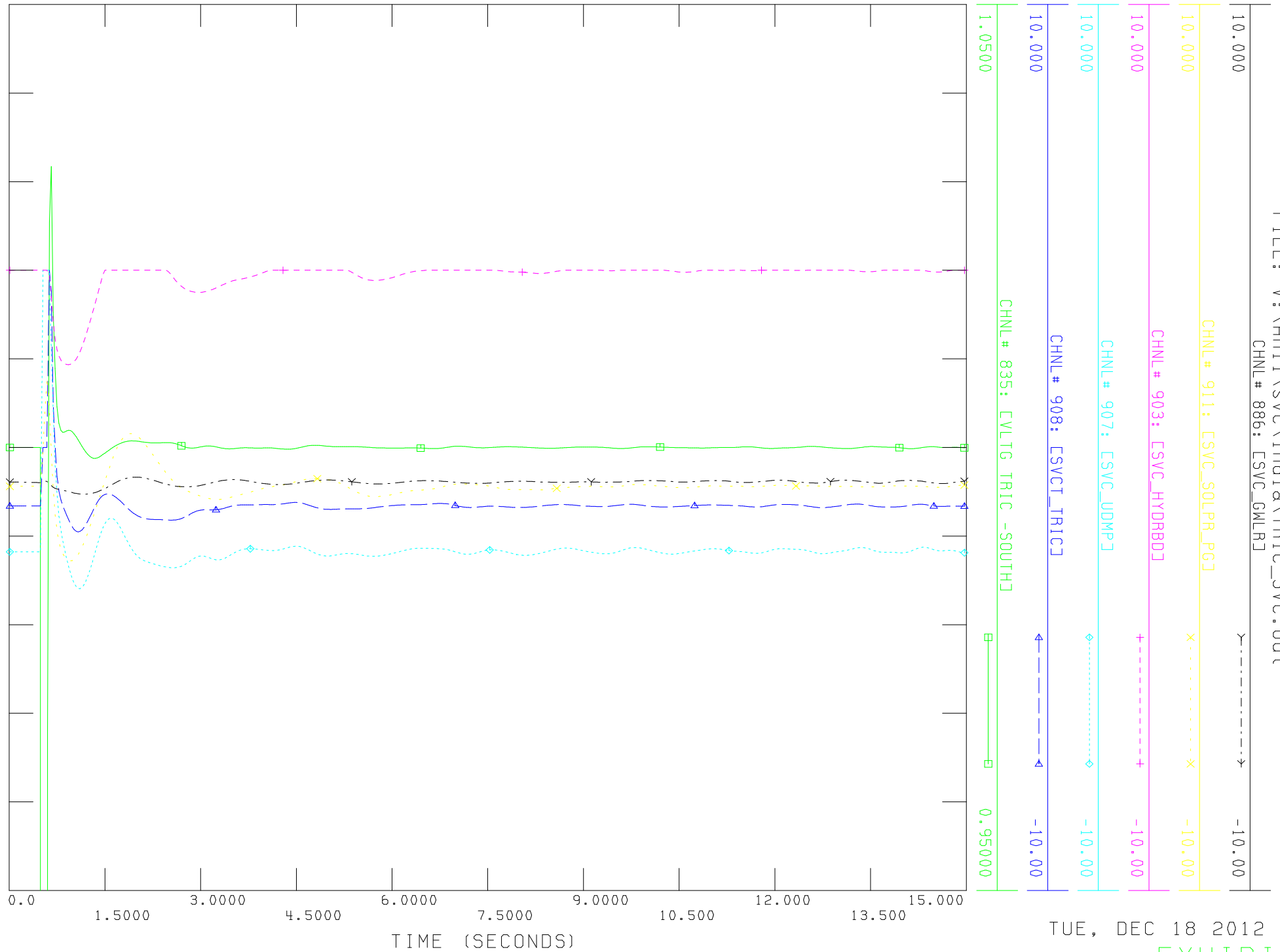

TUE, DEC 18 2012 12:51

EXHIBIT-36

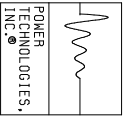

FAULT @ ROURKELA TRIP 400KV ROURKELA-RAIGARH 1

FILE: V:\An11\svc\India\Rourkela_SVC.out
CHNL # 894: [SVC_FATEHPUR]

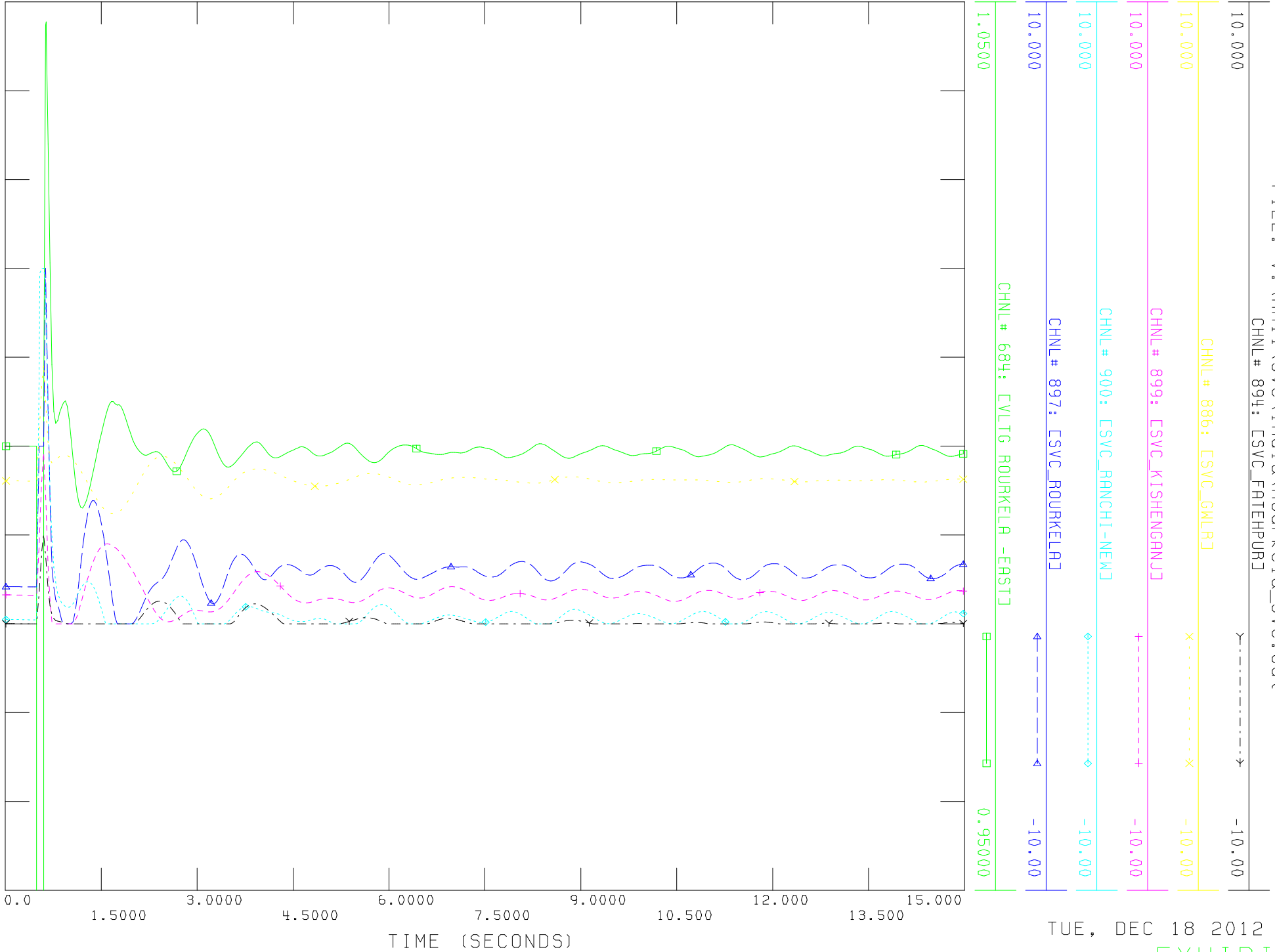

TUE, DEC 18 2012 13:10

EXHIBIT-37

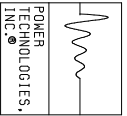

FAULT @ RANCHI (NEW) TRIP 400KV RANCHI-DHARAM JAYGARH 1

FILE: V:\Ani1\svc\India\Ranchi-Ranchi_svc.out
CHNL # 894: [SVC_FATEHPURJ]

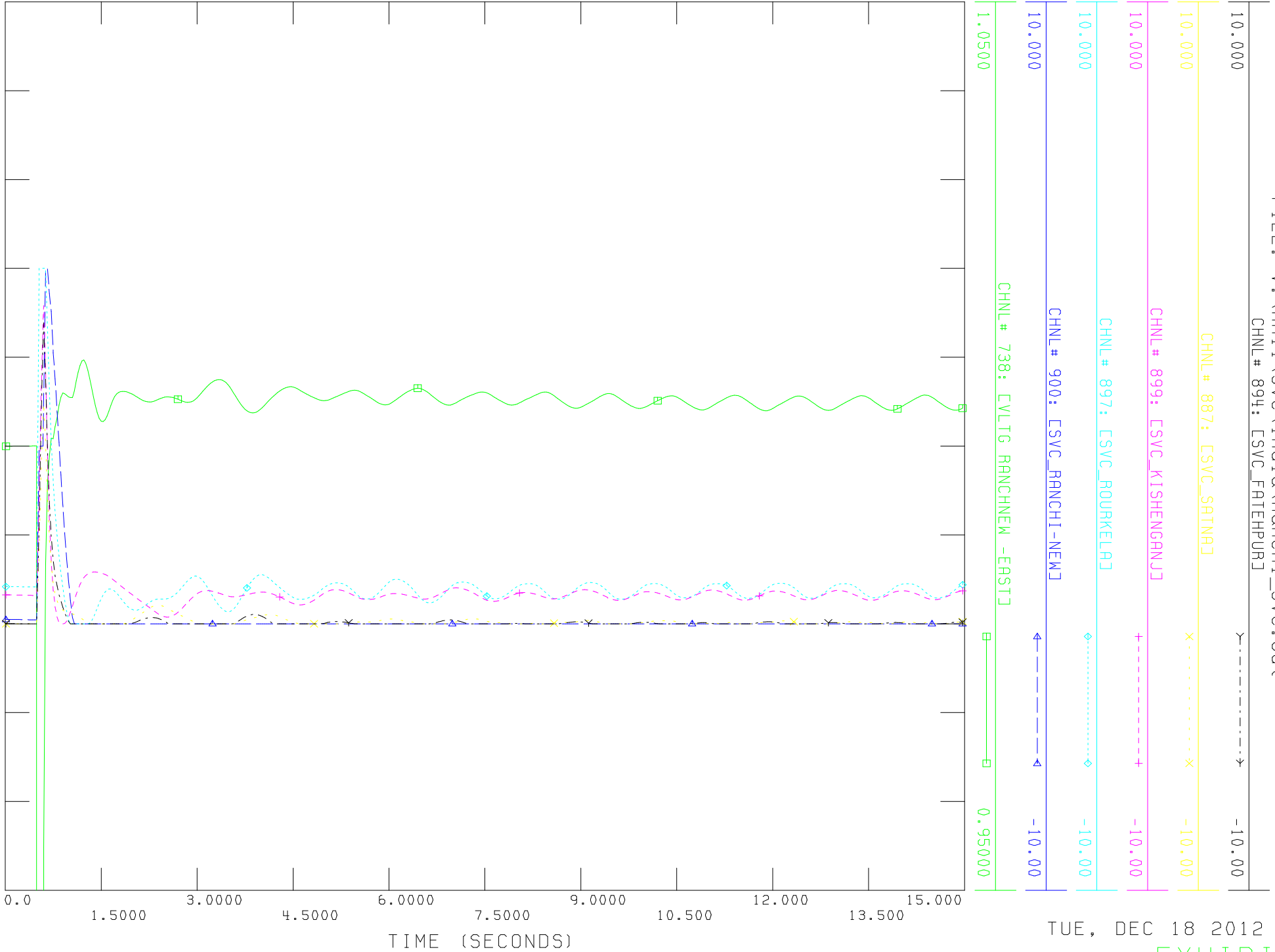

TUE, DEC 18 2012 13:20

EXHIBIT-38

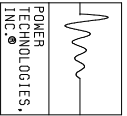

FILE: V:\Ani1\svc\India\Kishenganj_SVC.out
CHNL# 894: [SVC_FATEHPUR]

