

Annexure for Kerala Grid Strengthening

(Refer Agenda item no 28)

KERALA STATE ELECTRICITY BOARD LTD. MAJOR TRANSMISSION NETWORK OF KERALA FOR 2015-2022 (EXISTING & PROPOSED)

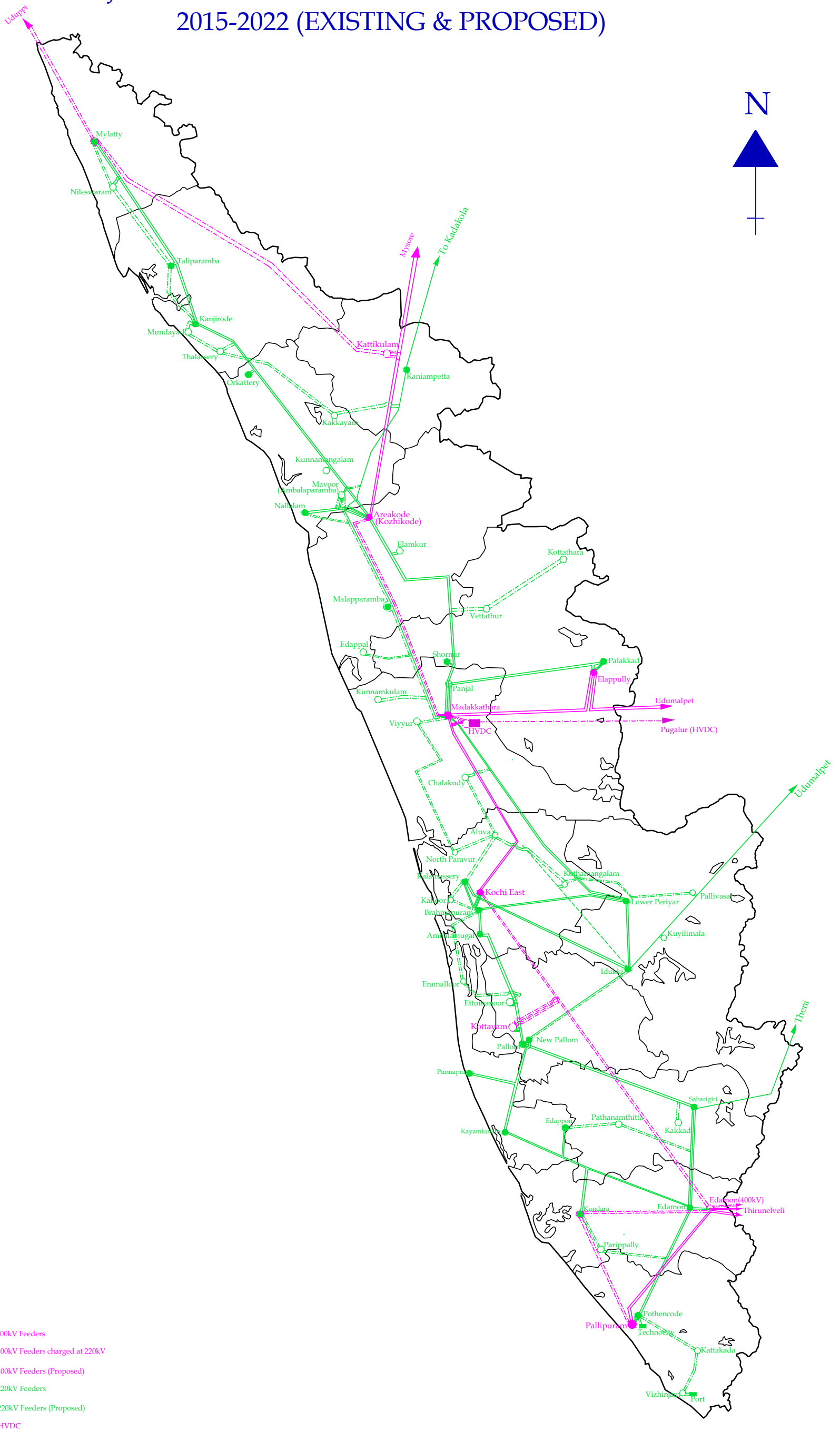

Legend

- 400kV Feeders
- 400kV Feeders charged at 220kV
- - - - - 400kV Feeders (Proposed)
- 220kV Feeders
- - - - - 220kV Feeders (Proposed)
- - - - - HVDC

TRANSMISSION PLAN STUDIES FOR THE PERIOD 2018-19
BASE CASE (WITH HVDC, TNVLI-COEST, UDML-PLKGD & MYSORE-KZKD)
THU, NOV 12 2015 16:23
PROPOSED 400kV NETWORK FOR THE STUDY PERIOD

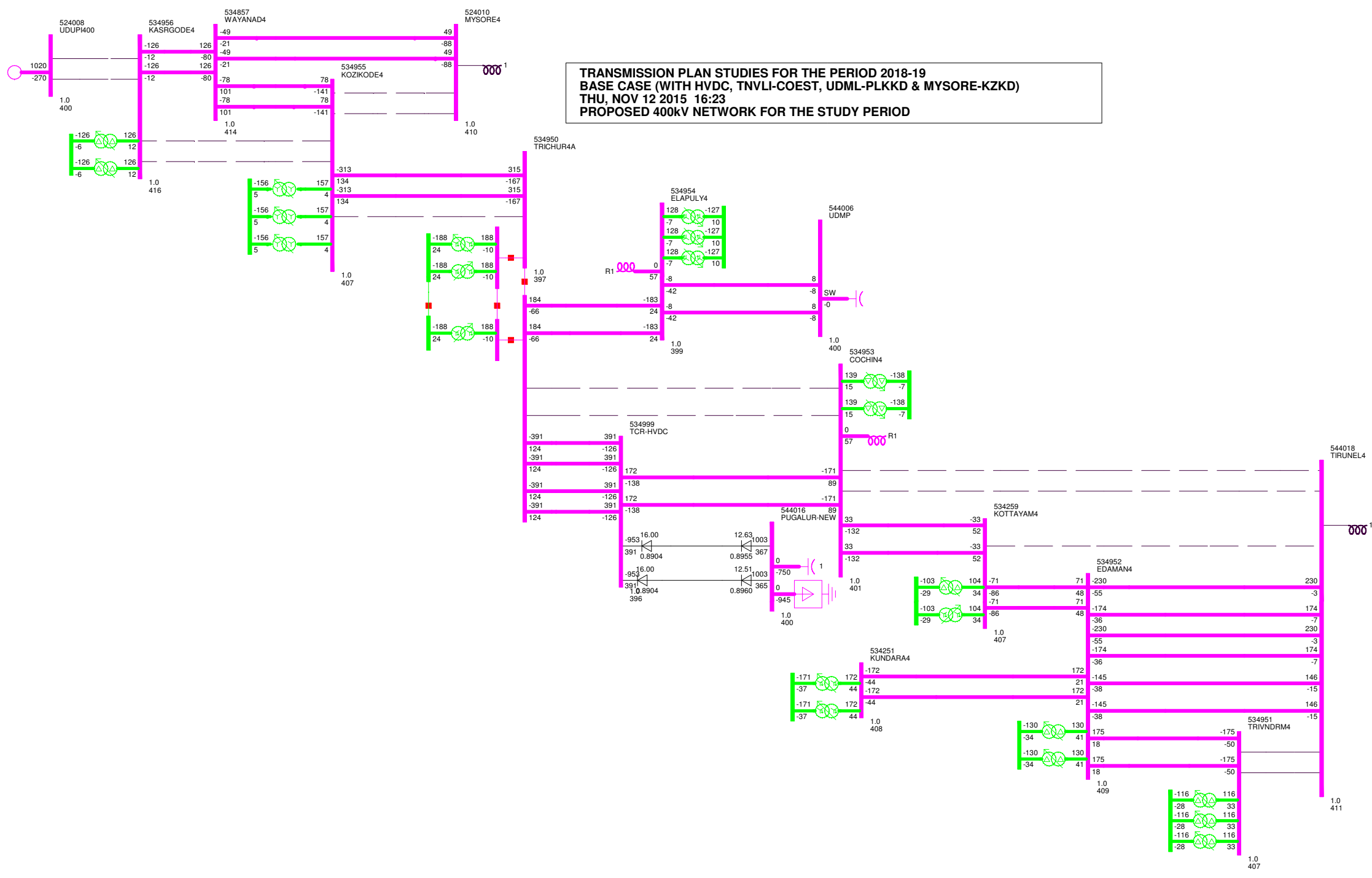

TRANSMISSION PLAN STUDIES FOR THE PERIOD 2018-19
CASE A - (WITH OUT 400KV UDML-PKGD)
THU, NOV 12 2015 16:29
PROPOSED 400KV NETWORK FOR THE STUDY PERIOD

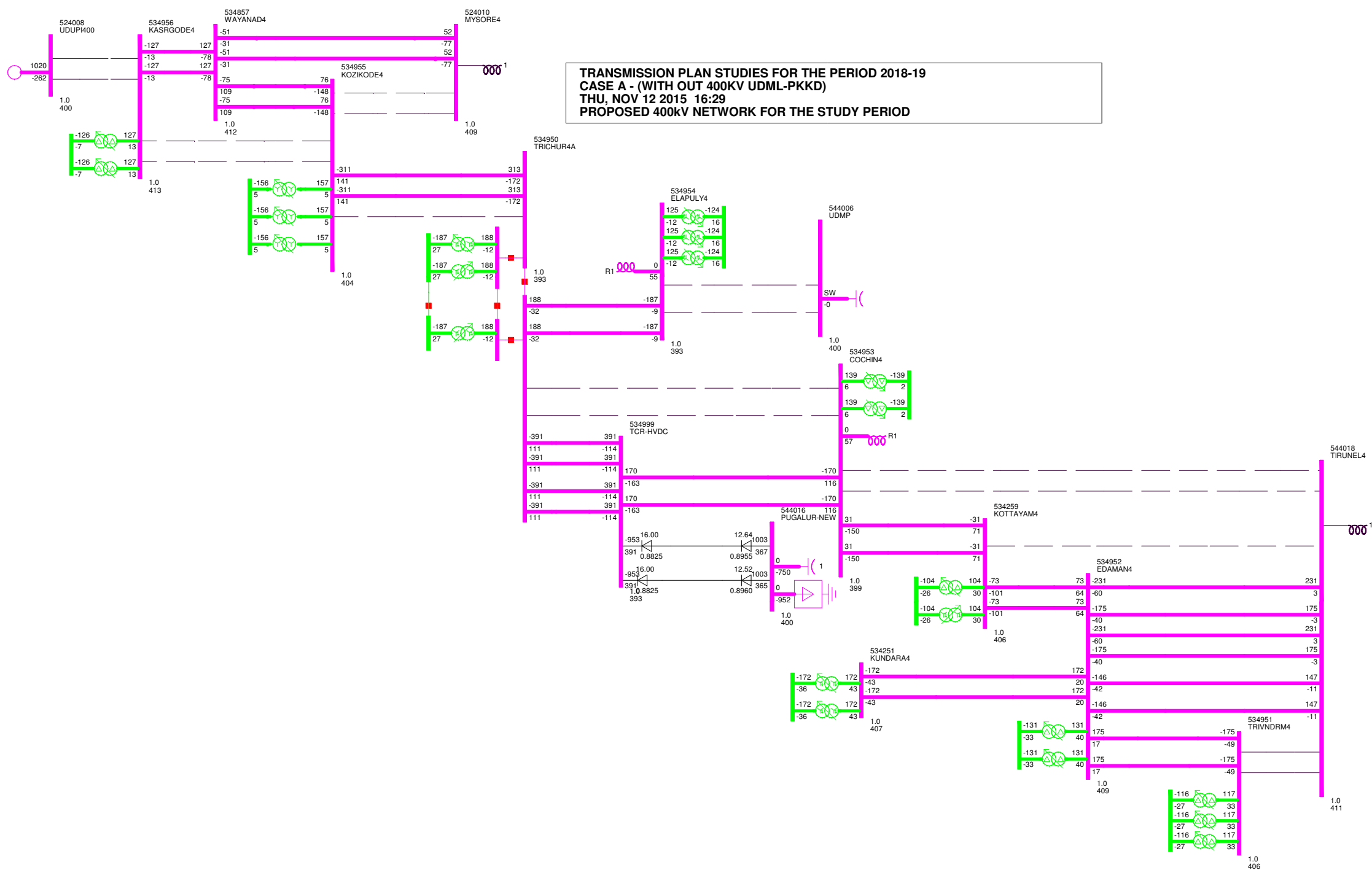

TRANSMISSION PLAN STUDIES FOR THE PERIOD 2018-19
CASE B - (WITH OUT TRICHUR HVDC)
THU, NOV 12 2015 16:26
PROPOSED 400kV NETWORK FOR THE STUDY PERIOD

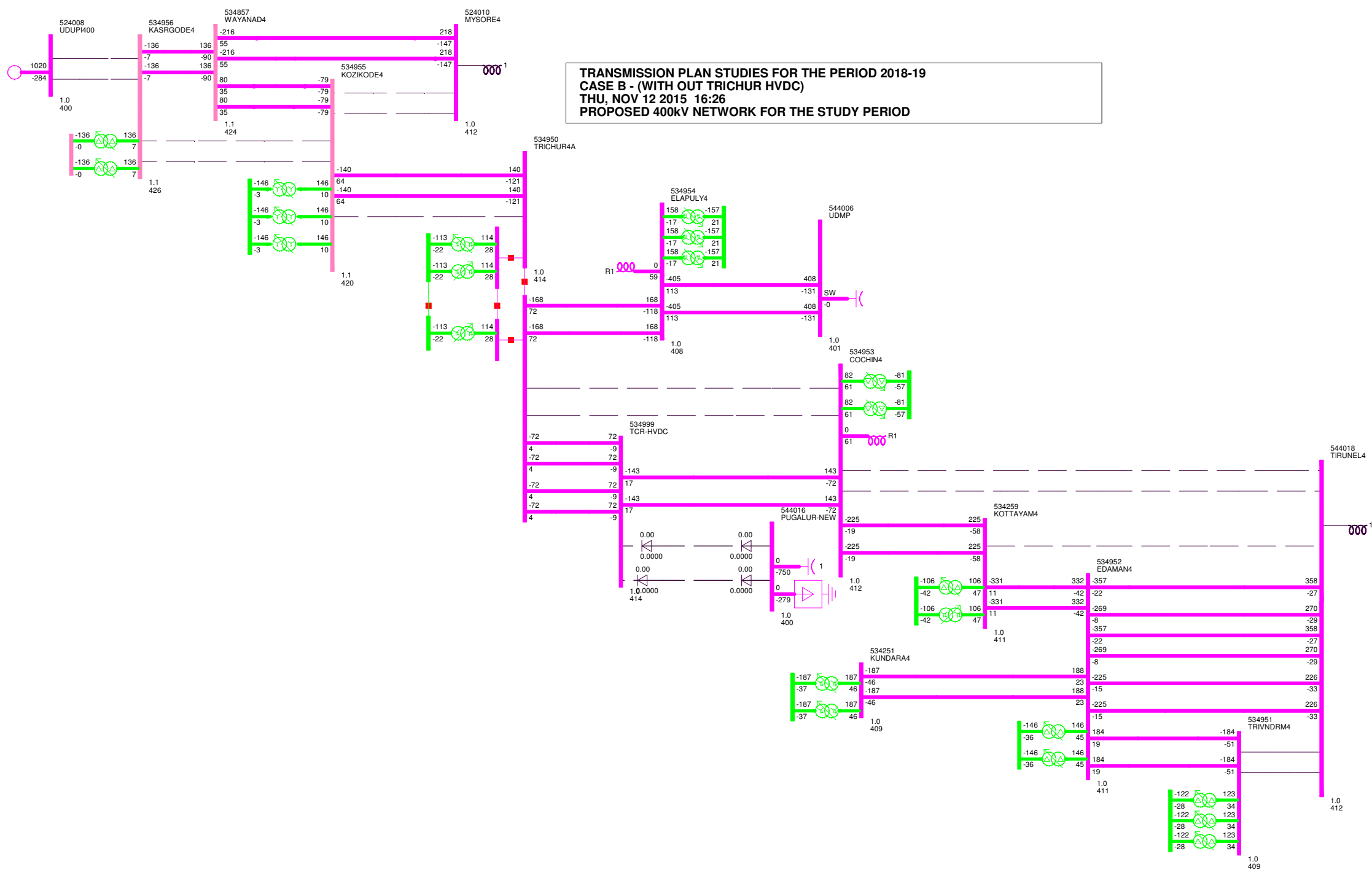

TRANSMISSION PLAN STUDIES FOR THE PERIOD 2018-19
CASE C - (WITH OUT 400KV TNVLI-EDMN)
THU, NOV 12 2015 16:34
PROPOSED 400KV NETWORK FOR THE STUDY PERIOD

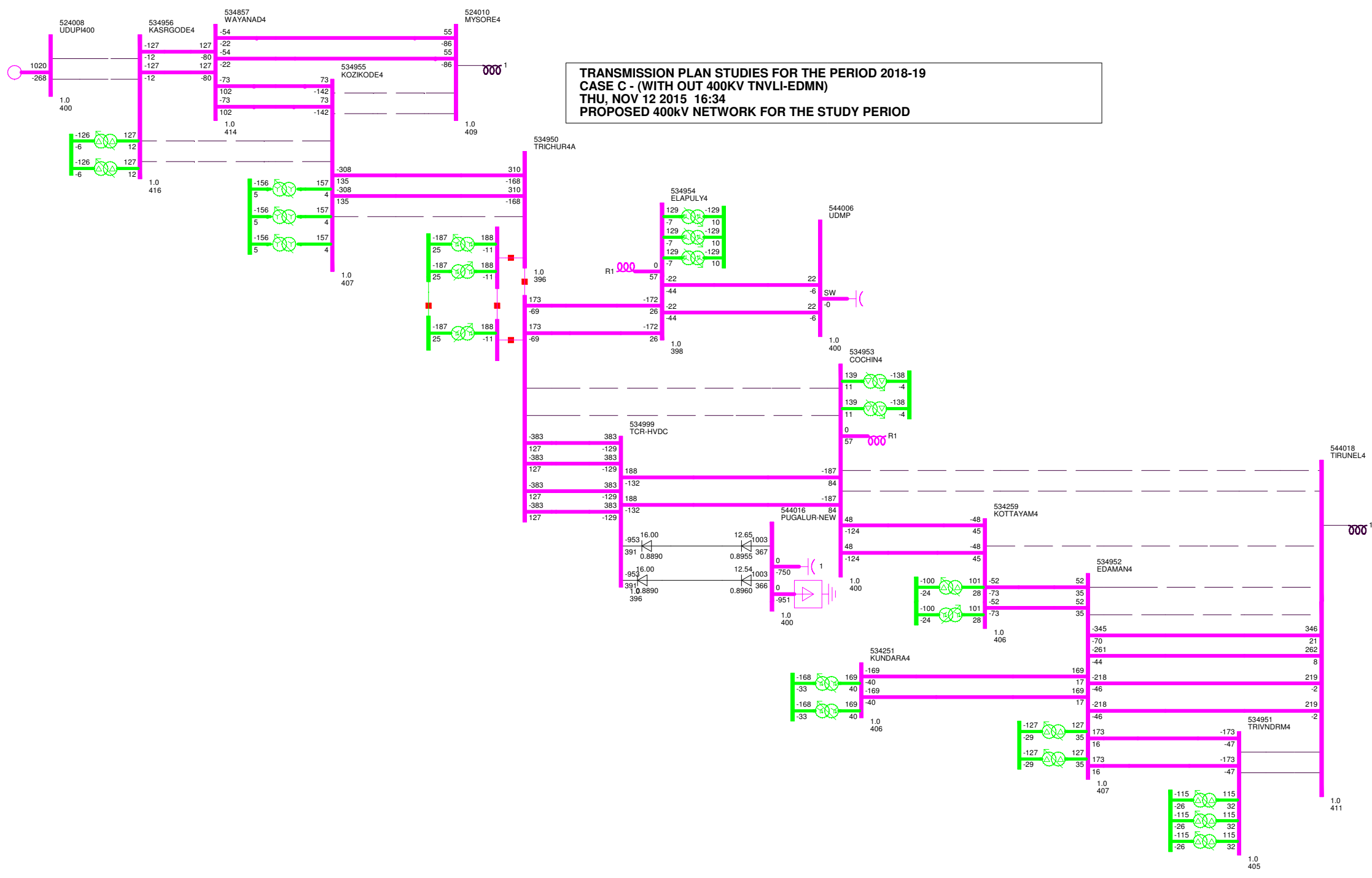

TRANSMISSION PLAN STUDIES FOR THE PERIOD 2018-19
CASE D - (WITH OUT 400KV MYSR-ARKD)
THU, NOV 12 2015 16:37
PROPOSED 400KV NETWORK FOR THE STUDY PERIOD

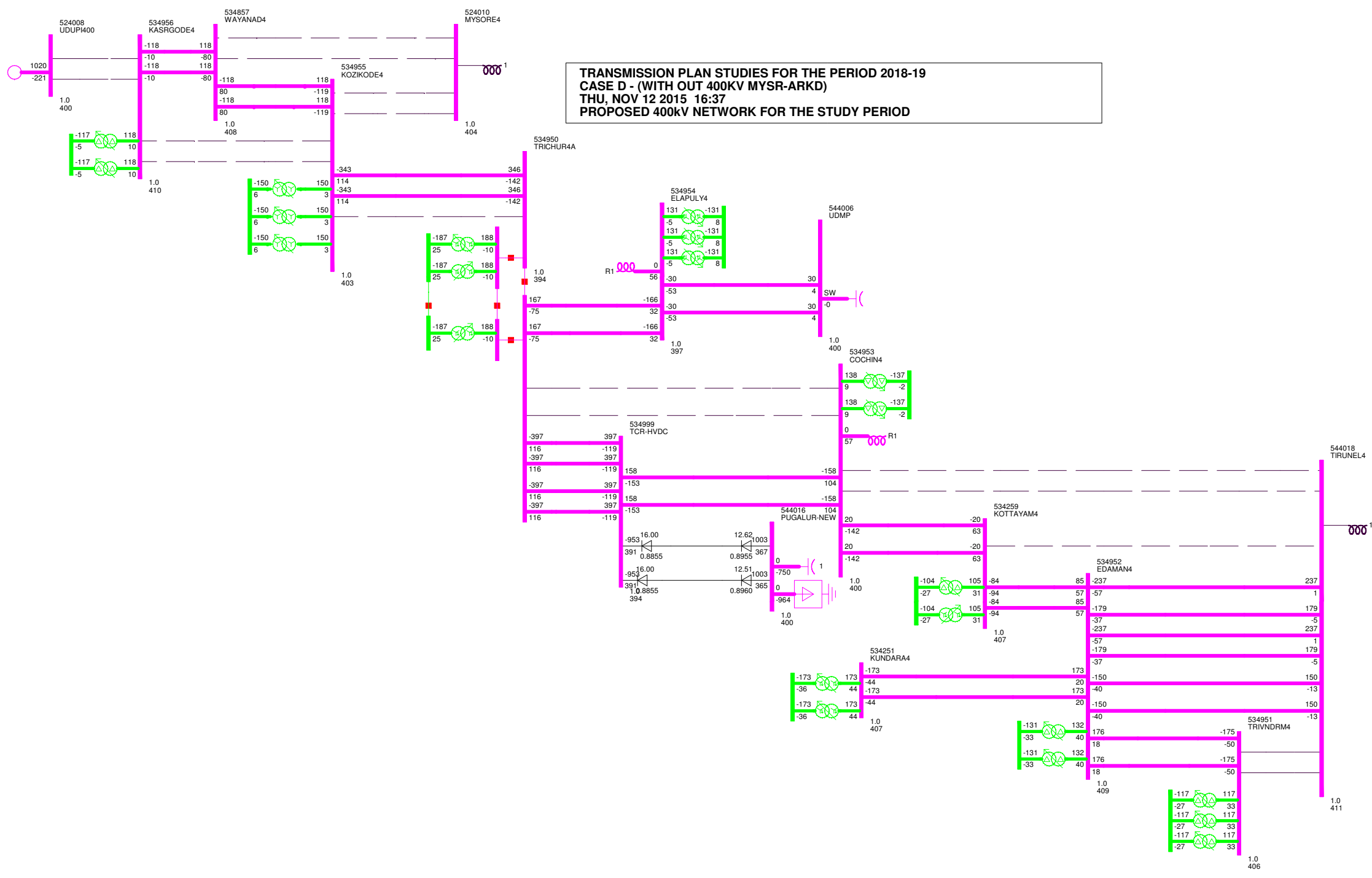

TRANSMISSION PLAN STUDIES FOR THE PERIOD 2018-19
CASE E - (WITH OUT EDMN-KTYM)
THU, NOV 12 2015 16:50
PROPOSED 400kV NETWORK FOR THE STUDY PERIOD

