



भारत सरकार  
Government of India  
विद्युत मंत्रालय  
Ministry of Power  
केंद्रीय विद्युत प्राधिकरण  
Central Electricity Authority  
विद्युत प्रणाली योजना एवं मूल्यांकन प्रभाग-II  
Power System Planning & Appraisal Division-II

संख्या : 66/5/2017/PSPA-2/1430-1444

Dated: 09.11.2017

To  
As per List Enclosed

**विषय :** पूर्वी क्षेत्र के लिए विद्युत प्रणाली योजना पर स्थायी समिति की 19 वीं बैठक का कार्यवृत्त ।  
**Subject:** Minutes of 19<sup>th</sup> Meeting of Standing Committee on Power System Planning for Eastern Region.

Sir/Madam,

Minutes of 19<sup>th</sup> Meeting of Standing Committee on Power System Planning for Eastern Region held on 01<sup>st</sup> September, 2017 at Kolkata is uploaded on the CEA website: ([www.cea.nic.in/Wings/Power Systems/PAP&A-II/Standing Committee on Power System Planning/Eastern Region](http://www.cea.nic.in/Wings/Power%20Systems/PAP&A-II/Standing%20Committee%20on%20Power%20System%20Planning/Eastern%20Region)).

Yours faithfully,

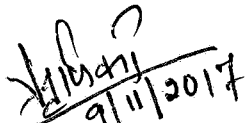
  
9/11/2017  
(रिषिका शरण /Rishika Sharan)  
निदेशक/ Director

Copy for kind information to:

- 1) PPS to Member PS, CEA

**List of addressee:**

1. Member Secretary, Eastern Regional Power Committee, 14, Golf Club Road, Tollygange, <b>Kolkata-700033.</b> <b>Tel. No. 033-24235199</b> <b>Fax No.033-24171358</b>	2. Managing Director, Bihar State Power Transmission Company, Vidyut Bhavan, Baily Road, Patna-800021. Tel. 0612-2504442 Fax No. 0612-2504557
3. Managing Director, Jharkhand Urja Sancharan Nigam Limited Engineering Building, H.E.C., Dhurwa, Ranchi-834004. <b>Fax-0651-2400799</b>	4. Director (Commercial), Grid Corporation of Orissa Ltd, Jan path, <b>Bhubaneswar-751022.</b> <b>Tel. No. 0674-2541127</b> <b>Fax No. 0674-2541904</b>
5. Director (Transmission), Orissa Power Transmission Corporation Ltd, Jan path, <b>Bhubaneswar-751022.</b> <b>Tel. No. 0674-2540098</b> <b>Fax No.0674-2541904</b>	6. Director (Operations), West Bengal State Electricity Transmission Company Ltd, Vidyut Bhavan(8 <sup>th</sup> Floor), Salt Lake City, <b>Kolkata-700091.</b> <b>Tel. No. 033-23370206</b> <b>Fax No.033-23345962</b>
7. Principal Chief Engineer cum Secretary, Power Department Government of Sikkim, Sikkim. Tel. No. 03592-2022440 Fax No.03592-202927	8. Director (System), Damodar Valley Corporation DVC Towers, VIP Road, Kolkata-700054. Tel. 033-23557934 Fax No. 23554841
9. CEO, POSOCO B-9, Qutub Institutional Area, Katwaria Sarai, New Delhi-110016 Tel. No. 26852843 Fax No. 2626524525, 26536901	10. Director (Projects), Power Grid Corporation of India "Saudamini" Plot No. 2, Sector-29, <b>Gurgaon-122001</b> <b>Tel. No. 0124-2571816</b> <b>Fax No.0124-2571932</b>
11. Director (Technical), NTPC Limited, Engineering Office Complex, A-8, Sector 24, <b>Noida.</b> <b>Tel. No. 24362050</b> <b>Fax No. 24362421</b>	12. Executive Director (T&RE), NHPC Ltd, NHPC Office complex, Sector 33, <b>Faridabad-121003.</b> <b>Tel. No. 0129-2255805</b> <b>Fax No. 0129-2277523</b>

**Copy to:**

13. General Manager, Eastern Regional Load  
Dispatch Center, 14, Golf Club Road,  
Tollygange,  
**Kolkata-700033. Fax No. 033-24235809**

15. Chairman-cum-Managing Director(CMD),  
Orissa Power Transmission Corporation  
Ltd(OPTCL),  
Jan path, **Bhubaneswar-751022.**  
**Tel. No. 0674-2540098**

14. Executive Director(EEM),  
Railway Board,  
Room No. 102-A, Rail Bhawan,  
New Delhi- 110001

## **Minutes of 19<sup>th</sup> Standing Committee Meeting on Power System Planning of Eastern Region**

Member (PS) welcomed the participants and thanked POWERGRID for hosting the meeting in Kolkata, “City of Joy”. He stated that the transmission system is planned for meeting future load growth, evacuation of power from upcoming generating projects and improving the reliability and availability of transmission system with the objective to deliver uninterrupted and quality power to the consumer. He requested the partner states to actively participate in discussion and to be specific on the issues so as to resolve all the issues amicably through healthy and result oriented discussions. He requested Chief Engineer, CEA to start the proceedings.

Chief Engineer (PSPA-2) also welcomed the participants and stated that transmission system planning is being carried out for meeting the future load growth of Eastern Region and for improving reliability of power supply. He stated that various issues relating to transmission, system strengthening, reactive compensation and measures to reduce fault level at various sub-stations of ER would be discussed in this meeting. He also raised the issue of Right of Way problems, and payment of compensation in constructing transmission lines. He stated that MoP has issued guidelines vide letter No. 3/7/2015-Trans dated 15.10.2015 for determining the compensation towards “damages”, in addition to the compensation towards normal crop & tree damages ( 66kV & above). After a brief introduction of participants, he requested Director (PSPA-2), CEA to take up the agenda items.

List of the participants is enclosed at **Annexure-I**.

### **1. Confirmation of the minutes of 18<sup>th</sup> Standing Committee Meeting on Power System planning of Eastern Region.**

- 1.1 Director (PSPA-2),CEA informed that the minutes of the 18<sup>th</sup> meeting of the Standing Committee on Power System Planning held on 13<sup>th</sup>June, 2016 at Kolkata were circulated vide CEA’s letter no. 66/5/SP7PA-2016/139-150 dated 19<sup>th</sup> August, 2016. ERPC vide their letter no. ERPC/MS/2016/767 dated 06.09.2016 and POWERGRID, vide their letter no. C/CTU-Plg/E/SCM dated 23-09-2016 had submitted their comments and a corrigendum was issued by CEA, vide letter No. CEA/PSPA-2/66/5/2016/265-275 dated 26.09.2016. Also, 2<sup>nd</sup> Corrigendum was circulated vide CEA’s letter No. 66/5/PSPA-II/2016/344-355 dated 20.10.2016. WBSETCL had also requested some modifications to the minutes vide their letter No. CE/CPD/CEA/1136 dated 05.10.2016 and accordingly, 3<sup>rd</sup> corrigendum was circulated vide CEA’s letter no. 66/5/PSPA-2/2016/413-423 dated 15.11.2016. She requested members to approve the minutes of 18<sup>th</sup> Standing Committee Meeting and the three corrigenda of the minutes.
- 1.2 The members approved minutes of 18<sup>th</sup> Standing Committee Meeting and the three corrigenda of the minutes.

**2. Termination of 400kV lines at Jeerat (WBSETCL) S/s under the ERSS-XV and ERSS-XVIII schemes**

2.1 Director (PSPA-2), CEA informed that Ministry of Power had appointed PFC Consulting Ltd (PFCCL) as BPC for ERSS-XVIII scheme. PFCCL intimated CEA that there was a RoW constraint for termination/interconnection of Jeerat(New) - Jeerat(WBSETCL) 400kV D/c (Quad) line to be executed under TBCB at the proposed GIS location at existing Jeerat(WBSETCL) substation. In order to address the RoW constraint, a joint team of officers of WBSETCL, CEA, CTU, PFCCL, POWERGRID (ER-II) visited the Jeerat substation of WBSETCL on 09<sup>th</sup> September, 2016. This was followed by a joint meeting of the above officers on 10<sup>th</sup> September, 2016 at WBSETCL's office at Kolkata. Further, she stated that following 400kV lines are existing / under construction / planned at 400/220kV substation of Jeerat (WBSETCL):

**Existing:**

- (i) Jeerat(WBSETCL) – Baharampur/Farakka 400kV S/c line of POWERGRID
- (ii) Jeerat(WBSETCL) – Rajarhat/Subhashgram 400kV S/c line of POWERGRID
- (iii) Jeerat(WBSETCL) – Barkeshwar(WBSETCL) 400kV S/c line of WBSETCL
- (iv) Jeerat(WBSETCL) – Kolaghat(WBSETCL) 400kV S/c line of WBSETCL

**Under Construction:**

- (v) LILO of Sagardighi – Subhashgram 400kV S/c line at Jeerat (WBSETCL) as a part of ERSS-XV – by POWERGRID

**Planned:**

- (vi) Jeerat (New) – Jeerat (WBSETCL) 400kV D/c line (quad) as a part of ERSS-XVIII – to be implemented as ISTS under TBCB by POWERGRID Medinipur-Jeerat Transmission Ltd.

2.2 Director (PSPA-2), CEA informed that during the above meeting, WBSETCL was requested to submit the detailed survey report regarding feasibility of overhead crossing of existing lines mentioned at 2.1(i) to 2.1(iv) by two D/c lines mentioned at 2.1(v) & 2.1(vi) for termination at GIS extension of Jeerat S/s of WBSETCL. WBSETCL vide its letter dated 05.10.2016 has submitted the detailed survey report, wherein WBSETCL mentioned that overhead crossing of the existing lines is not feasible as it requires long extensions for crossing towers as well as considerable space for maintaining required tower falling height.

2.3 Director (PSPA-2), CEA informed that a meeting was held on 14.12.2016 at CEA regarding the above issue. Copy of minutes of meeting issued vide letter dated 27.01.2017 is at **Annexure-2.1**. In the meeting, it was agreed that dismantling the crossing portion of the existing lines (ISTS and State lines) and termination of the existing lines through GIS bus duct might be the appropriate option, as the new lines mentioned at 2.1(v) and 2.1(vi) can be directly terminated on separate double ckt towers at normal height (around 45 meters) to new GIS extension area. In the meeting, it was agreed that following additional works may be

implemented at Jeerat S/s by POWERGRID under already approved ERSS-XV scheme:

- (i) Dismantling of dead end towers and termination of existing lines mentioned at 2.1 (i) to 2.1 (iv) through GIS duct to the existing 400kV Jeerat AIS S/s (WBSETCL).
- (ii) It was also agreed that the termination of the WBSETCL's lines mentioned at 2.1 (iii) & 2.1 (iv) shall be done through GIS duct at the existing 400kV Jeerat AIS S/s (WBSETCL). The work shall be implemented as ISTS and shall be included in the approved scope of ERSS-XV being executed by POWERGRID. The cost shall be recovered by POWERGRID as ISTS transmission tariff .
- (iii) Further, it was also acknowledged that implementation of LILO of Sagardighi-Subhasgram 400kV S/c line at Jeerat along with associated line bays shall get delayed by about one year due to addition of above mentioned GIS duct arrangement.
- (iv) The new lines mentioned at 2.1 (v) and 2.1 (vi) can be directly terminated on separate double ckt towers at normal height (around 45 meters) to new GIS extension area.

- 2.4 Director (PSPA-2), CEA informed that WBSETCL, vide letter dated 04.04.2017, informed that WBSETCL has considered and accepted the above mentioned additional work (Dismantling of dead end towers and termination through GIS Bus duct by POWERGRID under ISTS) decided in the meeting held on 14.12.2016 at CEA.
- 2.5 Chief Engineer (PSPA-II), CEA expressed that the portion of existing lines which are to be converted as GIS bus duct is around 600 meters and for the 4 existing S/c lines about 7.2km GIS bus duct would be required, which is a costly option. Instead of opting for GIS bus duct, low level gantry structure arrangement may be considered for crossing of the proposed new lines. He added that such arrangement would be cheaper compared to GIS bus duct option.
- 2.6 Representative of WBSETCL stated that the space at Jeerat substation is not sufficient to accommodate the gantry arrangement and procuring land in nearby areas of substation is also not possible.
- 2.7 In regard to query raised by Chief Engineer (PSPA-II) to change the orientation of proposed line to accommodate within the available space, representative of WBSETCL stated that the even after changing orientation, the available space would not be sufficient.
- 2.8 Representative of POWERGRID stated that estimated cost of the GIS bus duct proposal would be around ₹ 27 crores.
- 2.9 MS, ERPC asked whether the delayed implementation of the scheme would affect the export of additional 500MW power to Bangladesh as per the schedule. CTU informed that a study in this regard has been carried out and it has been observed that there would not be any constraint in exporting additional 500MW

power export to Bangladesh because of delay in implementation of LILO of Sagardighi – Subhashgram 400kV S/c line at Jeerat (WBSETCL) under ERSS-XV.

2.10 In view of the above, members agreed for the following:

- (i) Dismantling of dead end towers and termination of existing lines mentioned at 2.1 (i), 2.1 (ii) of POWERGRID & 2.1 (iii), 2.1 (iv) of WBSETCL through GIS duct, at the existing 400kV Jeerat AIS S/s (WBSETCL) as ISTS.
- (ii) The new lines mentioned at 2.1 (v) and 2.1 (vi) can be directly terminated on separate double circuit towers at normal height (around 45 meters) to new GIS extension area.
- (iii) Further, it was also acknowledged that implementation of LILO of Sagardighi-Subhasgram 400kV S/c line at Jeerat along with associated line bays shall get delayed due to addition of above mentioned GIS duct arrangement.

### **3. Creation of 220kV level at the under construction 400/132kV Motihari (TBCB) – Proposal of BSPTCL**

3.1 Director, BSPTCL stated that 400/132kV (2x200MVA) Motihari GIS substation is under construction through TBCB by M/s Essel Infra. BSPTCL had requested to create 220kV level in the 400/132kV Motihari GIS substation to avoid additional expenditure and time in creating a new 220/132kV Motihari (New) substation planned under intra-state strengthening scheme in 13<sup>th</sup> Plan.

3.2 Director (PSPA-2), CEA informed that a meeting was held at CEA on 18.01.2017 with the representatives of CTU and BSPTCL to discuss above issue. In the meeting, it was decided that shifting of the new 220/132kV S/s from Motihari (New) to Raxaul (New) with the following scope of works would be a better option.

#### **Raxaul (New) S/s: 220/132kV, 2x200MVA (to be implemented by BSPTCL)**

- (a) Sitamarhi (New) – Raxaul (New) 220kV D/c line (Twin Moose)
- (b) Raxaul (New) – Gopalganj 220kV D/c line (Twin Moose/ Single Zebra)
- (c) LILO of Bettiah – Raxaul 132kV D/c line at Raxaul (New)

3.3 Director (PSPA-2), CEA informed that following was agreed in the meeting:

- (i) The available space in the Motihari 400/132kV substation is not adequate to accommodate the proposed 220kV extension of BSPTCL. Creation of 220kV level would restrict any future expansion plans at Motihari S/s. Load flow results also shows that Motihari (TBCB) – Raxaul and Motihari (TBCB) – Bettiah 132kV D/c lines are critically loaded, when 220kV level is created at Motihari (TBCB) S/s.
- (ii) Earlier new 220/132kV substation at Motihari was planned primarily to feed the loads of Gopalganj, Bettiah and Raxaul. It was decided to shift the

planned substation towards Bettiah/Raxaul keeping the same connectivity. Based on the above observations and load flow studies, the new 220/132kV (2x200MVA) S/s may be created near Raxaul with Sitamarhi(New) – Raxaul(New) 220kV D/c (twin Moose) line and LILO of Bettiah – Raxaul 132kV D/c line.

- (iii) Considering the lower projected load growth of Bihar in 19<sup>th</sup> EPS, it was suggested that the implementation of Raxaul (New) – Gopalganj 220kV D/c may be taken up at a later date.
- (iv) BSPTCL may send their proposal on the basis of above discussion to CEA for taking up the matter in the forthcoming meeting of the Standing Committee (SCMPSPER) for finalization.

3.4 Director, BSPTCL stated that BSPTCL proposed to construct a new 220/132 kV (2x200 MVA) GSS near Raxaul with the following scope of works (to be implemented by BSPTCL).

- i) Raxaul (New) S/s: 220/132kV, 2x200MVA
- ii) Sitamarhi (New) – Raxaul (New) 220kV D/c line (Twin Moose)
- iii) \* Raxaul (New) – Gopalganj 220kV D/c line (Twin Moose/ Single Zebra)
- iv) LILO of Bettiah – Raxaul 132kV D/c line at Raxaul (New)

**Note:** \* this line may be implemented at later date.

The above substation is in place of Motihari new 220/132 kV, as proposed under 13<sup>th</sup> plan with the following scope of works.

- i) Sitamarhi (New) – Motihari (New) 220kV D/c line (Twin Moose)
- ii) Motihari (New) – Gopalganj 220kV D/c line (Twin Moose)
- iii) Motihari (New) – Raxaul 132kV D/c line
- iv) Motihari (New) – Bettiah 132kV D/c line (Single Moose)

3.5 Chief Engineer (PSPA-II), CEA stated that the conductor for Raxaul (New) – Gopalganj 220kV D/c is mentioned as twin moose or single zebra which are not having equal current carrying capacity.

3.6 Representative of CTU stated that loading on the Raxaul (New) – Gopalganj 220kV D/c line is around 70-90MW in the time frame of 2021-22. There are also other feeds at Gopalganj and hence it is possible that the loading of the line would not increase much in next 10 years. Therefore the type of conductor would be chosen as per the expected loading of the line at the time of implementation. In the case of Sitamarhi (New) – Raxaul (New) 220kV D/c line, it was informed that line is expected to carry about 235MW in the time frame of 2021-22 and hence it is recommended that the type of conductor may be either twin moose or equivalent HTLS.

3.7 Director, BSPTCL expressed that the tower weight of twin moose line would increase and therefore, overall cost would be more. He further stated that initially when the loading of Raxaul (New) – Gopalganj 220kV D/c line is less, zebra

conductor would be used. In case load increases, the conductor would be changed with HTLS conductor. He added that Sitamarhi (New) – Raxaul (New) 220kV D/c line may be implemented with either twin moose or equivalent HTLS conductor.

- 3.8 Chief Engineer (PSPA-II), CEA expressed that single HTLS conductor (instead of twin moose conductor) would result in reduction of tower weight and hence saving in cost. He stated that choosing of right conductor at planning stage would have advantage over changing the conductor at later stage.
- 3.9 The Motihari new 220/132kV sub station , as proposed was for 2021-22 time frame with the following scope of works.
2. Sitamarhi (New) – Motihari (New) 220kV D/c (Twin Moose)
  3. Motihari (New) – Gopalganj 220kV D/c (Twin Moose)
  4. Motihari (New) – Raxaul 132kV D/c
  5. Motihari (New) – Bettiah 132kV D/c ( Single Moose)

Based on discussions, members agreed to construct a new 2x200 MVA 220/132 kV GSS near Raxaul in place of Motihari new 220/132kV substation with the following scope of works (to be implemented by BSPTCL).

- i) Raxaul (New) S/s: 220/132kV, 2x200MVA
- ii) Sitamarhi (New) – Raxaul (New) 220kV D/c line (Twin Moose or equivalent HTLS)
- iii) \* Raxaul (New) – Gopalganj 220kV D/c line (#Twin Moose/Single Zebra or equivalent HTLS)
- iv) LILO of Bettiah – Raxaul 132kV D/c line at Raxaul (New)
- v) LILO of Bettiah – Raxaul 132kV D/c line at Raxaul (New)

**Note:** \*1. *this line may be implemented at later date.*

*#2. BSPTCL may choose right type of conductor at the planning/ implementation stage depending on system requirement/load growth and techno economic benefits.*

#### **4. Modifications/ additions in bay equipment of Maithon 400/220 kV sub-station of POWERGRID and generation switchyard of Maithon-RB**

- 4.1 Director (PSPA-2), CEA informed that reconductoring of Maithon RB- Maithon 400kV D/c line with HTLS conductor was approved in 18<sup>th</sup> Standing Committee Meeting held on 13.06.2016. It was agreed that along with line reconductoring, necessary modifications/ additions in bay equipment at Maithon 400/220kV sub-station of POWERGRID and at the generation switchyard of Maithon-RB would be carried out by POWERGRID. It was informed that approval under section-68 of Electricity Act-2003 has already been issued to POWERGRID on 07.02.2017 along with requisite modifications/ additions in bay equipment at Maithon 400/220kV sub-station of POWERGRID and at generation switchyard of Maithon-RB.



- 4.2 Members approved modifications/additions in bay equipment at Maithon 400/220kV sub-station of POWERGRID and at generation switchyard of Maithon-RB along with reconductoring of Maithon RB-Maithon 400kV D/c line.
- 5. Revised dedicated transmission system for Lanco Babandh Power Pvt. Ltd.(2x660 MW)**
- 5.1 Director (PSPA-2), CEA informed that Lanco Babandh generation project (4x660MW) was granted LTOA of 1600MW (NR-650MW & WR-950MW) by CTU vide its letter C/ENG/E/00/SEF/OA dated 14.05.2009 with the following dedicated transmission system.
- 400kV Lanco Babandh TPS - 765/400 kV Angul Pooling station (PGCIL) 2xD/c lines with associated bays to be developed as a dedicated lines by the generation developer.
  - 3X1500 MVA, 765/400 kV ICTs at Angul with associated bays to be developed by the generation developer.
- 5.2 Director (PSPA-2), CEA informed that MoP vide its letter no. 11/2/2011-PG(LBPL) dated 09.06.2011 has granted prior approval of the Government under section 68 of the Electricity Act 2003 based on minutes of 11<sup>th</sup> meeting of Standing Committee Meeting on Power System Planning in Eastern Region held on 20.09.2010 with the above scope of work. This approval expired on 08.06.2014 because the implementing agency did not start the construction works within 3 years from date of grant of Sec-68 approval.
- 5.3 CTU informed that Lanco Babandh Power Pvt. Ltd. (LBPPL) has relinquished its long term access to the tune of 800MW in line with CERC order dated 08.06.2013 in petition No: 118/MP/2012 due to non-implementation of Phase-II(2x660MW). Revision of LTOA from 1600MW to 800MW was issued to LBPL with allocation of NR-650MW & WR-150MW based on the minutes of 11<sup>th</sup> Connectivity and LTA meeting of ER held on 13.06.2016. The following revised dedicated transmission system was proposed by CTU vide its letter No. C/CTU-Plg/E/LTA/Lanco Babandh dated 19.10.2016 based on the revised LTOA quantum of 800MW.
- Lanco Babandh Gen Switchyard - Angul 400kV D/c line (with conductor Equivalent to triple ACSR snow bird or higher size)
  - 2X1500 MVA, 765/400 kV ICT (7x500MVA single phase units) at Angul along with associated bays
- 5.4 Director (PSPA-2), CEA informed that Lanco vide letter dated 15-11-2016 requested for review of requirement of above mentioned revised dedicated system on mutually agreed terms in view of non-commissioning/non-implementation of certain generation projects at Angul. The revision of Lanco's dedicated system is being considered at its own request and also on its own risk and cost. Further, as Lanco has relinquished LTA for 800 MW under Petition No. 118/MP/2012 and is also presently contesting a petition (38/MP/2016) before CERC *inter alia* seeking abeyance of LTA, the revision discussed hereunder

shall be without prejudice to the proceedings before CERC and to Lanco's liability(ies) towards payment of relinquishment/transmission charges as the case may be.

- 5.5 Representative of CTU stated that total common system required for evacuation of phase-I generation projects in Odisha including Lanco Babandh Power Private Limited (LBPPL) had commissioned in January 2016. LBPPL would be liable to pay LTA charges for 800MW from January 2016. He stated that LBPPL have not yet opened Letter of Credit (LC) for paying transmission charges. Representative of CTU further added that LBPPL had applied for LTOA for 1600MW originally. The 3x1500MVA, 765/400kV ICT (7x500MVA single phase units) at Angul along with associated bays were proposed as a part of its dedicated transmission system. The ICTs were proposed to be installed at Angul, as there was space constraint at generation switchyard of LBPPL.
- 5.6 Representative of OPTCL stated that the allocation of power from LBPPL for Odisha is 25%. Therefore, 400kV level connectivity to Khuntuni (Odisha) may also be considered. Representative of CTU stated that even if Odisha intends to draw its share through Khuntuni, LBPPL or Odisha will have to pay PoC charges for drawl of Odisha's share.
- 5.7 Further, Representative of OPTCL informed that LBPPL, in 13<sup>th</sup> JCC, had intimated the commissioning schedule of their first unit as September 2018 and that of the second unit as January 2019. The project is facing financial constraints. LBPPL has neither awarded construction of its dedicated line nor the ICTs or line bays at Angul.
- 5.8 Chief Engineer (PSPA-II), CEA expressed that as the project is delayed and uncertain, it is prudent that the dedicated scheme to be implemented by LBPPL, may not be changed.
- 5.9 In view of the above presented facts members decided that as the generation project is now being developed by project developer in two phase (each phase of 2x660MW), the originally identified dedicated system (mentioned at para 5.1 above) may also be built by project developer in two phases as mentioned below without any modification to the originally identified dedicated system:

**Phase-1: With Unit 1 & 2 of generation project**

- a) Lanco Babandh Gen Switchyard – Angul 400kV D/c line ( with conductor equivalent to triple ACSR snow bird or higher)
- b) 2X1500 MVA, 765/400kV ICT (7x500MVA single phase units) at Angul along with associated bays

**Phase-2: With Unit 3 & 4 of generation project**

- a) Lanco Babandh Gen Switchyard – Angul 400kV 2<sup>nd</sup> D/c line ( with conductor equivalent to triple ACSR snow bird or higher size)
- b) 1X1500 MVA, 765/400kV 3<sup>rd</sup> ICT (3x500MVA single phase units) at Angul along with associated bays

**Note:** The above phasing of Lanco's dedicated system is being considered at its own request and also on its own risk and cost. Further, as Lanco had relinquished LTA for 800MW under Petition No. 118/MP/2012 and is also presently contesting a petition (38/MP/2016) before CERC inter alia seeking abeyance of LTA, this phasing of dedicated system shall be without prejudice to the proceedings before CERC and to Lanco's liability(ies) towards payment of relinquishment/transmission charges as the case may be.

5.10 Representative of POWERGRID stated that for reliable communication system, OPGW may be provided instead of normal earth wire.

5.11 Members agreed for above.

## **6. Evacuation of power from Patratu (3x800MW) TPS**

6.1 Director (PSPA-2), CEA informed that Patratu Vidyut Utpadan Nigam Limited (PVUNL) (3X800+2X800MW) is a joint venture of NTPC Ltd. and the Jharkhand state government owned Patratu Thermal Power Station (PTPS). A meeting regarding evacuation of power from Patratu (3x800MW) TPS was held on 20.01.2017 at CEA. In the meeting, CTU representative informed that Patratu Vidyut Utpadan Nigam Ltd. (PVUNL) has applied for connectivity of 2400MW (Phase-I), to the ISTS system, from Dec, 2020 for their planned Patratu (3x800MW) TPS situated in Ramgarh District of Jharkhand.

6.2 In the meeting PVUNL informed that 85% of power is allocated to Jharkhand state and 15% is kept as unallocated power. This matter was discussed in meeting at CEA and it was agreed that as majority of power of Patratu TPS is allocated to Jharkhand, it would be prudent that Patratu TPS is directly connected with JUSNL (Jharkhand STU) system and not ISTS system. If remaining share (15%) of power of Patratu TPS is to be transferred outside Jharkhand, for such quantum PVUNL may apply for ISTS Long Term Access to CTU (POWERGRID), as per CERC Connectivity Regulations, 2009.

6.3 Director (PSPA-2), CEA informed that joint studies were carried out to evolve immediate evacuation system for Patratu (3x800MW) TPS. Accordingly following power evacuation system from Patratu (3x800MW) TPS was evolved:

- (a) Patratu gen. switchyard – Patratu (JUSNL) S/s 400kV (Quad) D/c line
- (b) Patratu gen. switchyard – Koderma (JUSNL) S/s 400kV (Quad) D/c line
- (c) Patratu gen. switchyard – New Chandil (JUSNL) S/s 400kV (Quad) D/c line
- (d) 420kV, 2x125MVAR bus reactors at Patratu gen. switchyard and 420kV, 1x125MVAR bus reactor at Patratu 400kV bus
- (e) From Patratu 400/220/132kV substation:
  - (i) Patratu (JUSNL) S/s to Latehar 400kV D/c line (already under construction)
  - (ii) Patratu (JUSNL) to Ranchi (POWERGRID) 765/400kV S/s 400kV D/c line (already under construction) along with LILO of both circuits at Mandar 400/220kV S/s

- 6.4 In this way, Patratu generation would also get connected to strong ISTS pooling stations viz. (i) Ranchi (POWERGRID) 765/400kV through Patratu (JUSNL) and (ii) Chandwa Pool (POWERGRID) through Patratu (JUSNL) & Latehar (JUSNL) substations of JUSNL.
- 6.5 Further, she informed that the connectivity of Patratu (3x800MW) TPS to Koderma (northern part of Jharkhand) and New Chandil (south-eastern part of Jharkhand) through 400kV high capacity (Quad Moose) double circuit lines would facilitate the transfer of power from Patratu TPS to different load centers in Jharkhand. These interconnections would complete the 400kV high-capacity ring viz. **Patratu TPS – Koderma – Jasidih – Dhanbad (ISTS) – New Chandil – Patratu TPS** in Jharkhand, which shall improve reliability of power transfer within the state.
- 6.6 Director (PSPA-2), CEA informed that it was also observed from the joint studies that three-phase fault level at 400kV level at both Patratu (3x800MW) TPS and Patratu (400/220kV) substation is about 50kA. Accordingly, it was decided that 400kV bus at Patratu generation switchyard as well as Patratu (400/220kV) substation (JUSNL) would be designed for short circuit level of 63kA (for 1sec).
- 6.7 In the meeting PVUNL had informed that construction is yet to start at Patratu (400/220kV) substation. Therefore, it was suggested that JUSNL would explore possibility of construction of 400kV and 220kV level at Patratu (400/220kV) substation with short circuit level of 63kA and 50kA respectively.
- 6.8 Representative of PVUNL stated that they are facing difficulty in filing application for connectivity to JUSNL as there is no formal procedure for application connectivity/ LTA. Further, he informed that NIT and price bid have already been opened for the project.
- 6.9 Member (Power system), CEA stated that PVUNL may pursue with Government of Jharkhand.
- 6.10 Chief Engineer (PSPA-II), CEA expressed that PVUNL is planning for evacuation of power generation in two phases and many 400kV connections are planned in the first phase and therefore, evacuation of power in second phase generation may be difficult because of RoW constraints. He suggested that use of multi circuit towers ( more than 2 circuit) at 400kV level may be considered for evacuation of power.
- 6.11 He stated that PVUNL should apply for LTA and connectivity to JUSNL and therefore ISTS Connectivity application of PVUNL may be closed.
- 6.12 Members agreed for power evacuation system from Patratu (3x800MW) TPS as mentioned at para 6.3 as intra state system of Jharkhand. Members also agreed that ISTS Connectivity application of PVUNL for Patratu TPS to CTU may be closed and PVUNL may apply for connectivity of its Patratu (3x800MW) TPS to JUSNL. Jharkhand may consider to use 400kV multi circuit towers ( more than 2 circuit) for optimum utilization of available corridor.

**7. Perspective transmission plan of JUSNL up to 2021-22**

7.1 Director (PSPA-2), CEA informed that total load projected for Jharkhand for the year 2021-22 is around 5613MW (4193MW for JUSNL area + 1420MW for DVC area) as stated by JUSNL. Load flow studies were carried out for projected peak load of Jharkhand as 4193MW for the year 2021-22. JUSNL had submitted draft report on perspective transmission plan of JUSNL up to 2021-22. In the meetings held on 26.10.2017 and 20.01.2017, some modifications were proposed by CEA and CTU to incorporate in the study. JUSNL incorporated these changes and submitted the compliance report vide their email dated 01.02.2017.

7.2 Director (PSPA-2), CEA informed that the following 400/220kV intra-state substations along with downstream connectivity mentioned at **Annexure-7.1** were agreed under perspective transmission plan of JUSNL up to 2021-22:

- (i) Jasidih (400/220kV, 2x500MVA)
- (ii) New Chandil (400/220kV, 2x500MVA)
- (iii) Koderma (400/220kV, 2x500MVA)
- (iv) Mandar (400/220kV, 2x500MVA)
- (v) Dumka (400/220 kV , 2x500 MVA) (with commissioning of Tenughat Ph-2 (1320 MW))

*Note: 420kV, 2x125MVAR bus reactors may be installed at all of the above new 400kV substations of JUSNL for voltage control.*

7.3 Further, she informed that the transmission system planned for JUSNL network along with evacuation system of PVUNL would create a high capacity 400kV ring **Patratu TPS – Koderma – Jasidih – Dhanbad (ISTS) – New Chandil – Patratu TPS** in Jharkhand, which would improve reliability of power transfer within the state. The intra-state system of Jharkhand would also get well interconnected at various ISTS points for smooth power exchange.

7.4 Representative of CTU stated that 220kV D/c line considered from Chaibasa (JUSNL) to Ramchandrapur 220/132kV substation was earlier envisaged as Chaibasa (POWERGRID) to Ramchandrapur 220/132kV substation. In the 18<sup>th</sup> SCM of ER, JUSNL had informed following outlets for utilization of 4 no. 220kV line bays at Chaibasa (POWERGRID) substation:

- (i) Chaibasa (POWERGRID) – Chaibasa (JUSNL) 220kV D/c
- (ii) Chaibasa (POWERGRID) – Ramchandrapur (JUSNL) 220kV D/c line

However, as per detailed scope of work submitted by JUSNL, the line at (ii) above is proposed to be terminated at Chaibasa (JUSNL) substation and hence connectivity considered in revised draft report studies i.e. Chaibasa (JUSNL) – Ramchandrapur 220kV D/c line is retained. Accordingly, it is imperative that JUSNL may plan a new outlet from Chaibasa (POWERGRID) to utilize the

remaining 2 no. 220kV line bays already constructed. As no representative from JUSNL attended the meeting, the matter could not be discussed.

- 7.5 Representative of DVC stated that it has been observed that some connectivity proposed in the perspective transmission plan of JUSNL have been planned with DVC system like Koderma (DVC), CTPS (DVC) without consultation with DVC. He added that JUSNL have even requested for land availability at some of the DVC substations without any prior discussion with DVC. He requested for revised load flow study of perspective transmission plan of JUSNL up to 2021-22 with the involvement of DVC.
- 7.6 Members decided that a separate meeting at CEA would be held to discuss the perspective transmission plan of JUSNL up to 2021-22 with the involvement of DVC.

**8. Transmission system for evacuation of power from Buxar Thermal Power Project (1320 MW) – Agenda of BSPTCL**

- 8.1 Director, BSPTCL informed that evacuation system for Buxar Thermal Power Project was earlier planned under 12<sup>th</sup> plan. Due to unavailability of land and other issues the evacuation system of the project was revised. He stated that initially at 400kV level the evacuation was planned through Buxar TPS- Bihta 400kV D/c line. Instead of Bihta, the line is proposed to be terminated at Naubatpur, as the new substation is being implemented at Naubatpur in place of Bihta. He informed that generation is proposed to be stepped up to 400kV level and accordingly joint system studies were conducted with POWERGRID and following revised evacuation system for the project have been evolved :

**400kV**

- Buxar TPS- Naubatpur 400kV D/C

**220kV**

- Buxar TPS- Dumraon new 220kV D/C (Twin Moose)
- Buxar TPS-Pusauli (BSPTCL) 220kV D/C (Twin Moose)
- Buxar TPS-Dehri 220kV D/C
- 2X500MVA 400/220kV ICT at Buxar generation switchyard-under the scope of respective generation project.

- 8.2 Representative of CTU stated that in case of outage of 400kV transmission line, the entire power would be evacuated through 220kV level. It is therefore prudent to plan 3<sup>rd</sup> 500MVA, 400/220kV ICT as this would increase the reliability of the system. In case, BSPTCL decides to install only two ICTs initially then space for third ICT should definitely be kept.
- 8.3 It was opined in the meeting that BSPTCL may use twin moose or equivalent HTLS conductor for 400kV line as per system requirement at the time of implementation.
- 8.4 Director, BSPTCL agreed for the above mentioned recommendations at para 8.2 and 8.3.

- 8.5 Members agreed for the evacuation system for Buxar Thermal Power Project (1320MW) mentioned below, which is to be implemented as intra-state system by BSPTCL.

**400kV**

- Buxar TPS- Naubatpur 400kV D/C (with twin moose or equivalent HTLS conductor)

**220kV**

- Buxar TPS- Dumraon new 220kV D/C line (Twin Moose)
- Buxar TPS-Pusauli (BSPTCL) 220kV D/C line(Twin Moose)
- Buxar TPS-Dehri 220kV D/C line
- 2x500MVA, 400/220kV ICT at Buxar generation switchyard-under the scope of respective generation project and space for third ICT may be kept.

**9. Connectivity of Railway TSS with ISTS network for Mughal Sarai – Howrah route**

- 9.1 Director (PSPA-2), CEA informed that Railway Board vide its letter dated 09.09.2016 had requested for connectivity to Railways from various ISTS points to feed their TSS (Traction Sub Station) for Mughal Sarai(NR) – Howrah(ER) route. A meeting was held on 07.10.2016 in CEA to discuss the connectivity of Railways' TSS with ISTS network for two routes of Railways i.e. (i) Delhi (NR) – Bharuch (WR) route (ii) MughalSarai (NR) – Howrah (ER) route. In the meeting, following ISTS substations were preliminarily identified for giving connectivity to the Railways TSS for its Mughalsarai (NR) – Howrah (ER) route:

- (i) Arrah or Patna
- (ii) Gaya or Chandauti
- (iii) Maithon
- (iv) Durgapur
- (v) Lakhisarai
- (vi) Subhashgram

- 9.2 Further, she stated that a meeting was held on 20.04.2017 at CEA with STUs regarding connectivity of Railways with ISTS network for the Mughalsarai – Howrah (MoM is enclosed at **Annexure-9.1**). In the meeting DVC stated that Railways load of DVC is about 320MW and is supplying power at average cost of Rs. 4.80 per unit, which is quite competitive price. Railways agreed with DVC and stated that Mughalsarai - Howrah route has been planned in holistic way, therefore, Railways would be disconnect from DVC system also in this route.

- 9.3 Representative of Railways stated that basis for planning of ISTS connectivity instead of STU connectivity are economics, reliability and increase in load with Dedicated Freight Corridor. He stated that Railways had requested for ISTS connectivity for Mughalsarai – Howrah route at certain points. After finalizing

these ISTS connection points for the above route, Railways would plan in detail for the transmission system in this route.

- 9.4 Director, (PSPA-II) stated that CEA had requested for submission of economic analysis of shifting of Railway load from STUs/DVC to ISTS in this route. Railways have not submitted the same.
- 9.5 Member Secretary, ERPC stated that in the State Sector Standing Committee Meeting for Eastern Region held on 03.08.2017, following concerns were raised by the ER constituent states.
- (i) States have developed many transmission networks and sub-stations dedicated to Railways for reliable supply to them. If railways connect directly to ISTS through their dedicated lines, the corresponding STU system will become defunct and there would be a huge wastage of public money. The usage of STUs stranded assets need to be explained.
  - (ii) In the ISTS substations, space is kept for 220kV or 400kV bays for states to meet their future load demand. In case railways uses the existing space at ISTS substations for their 220kV lines, how the future power requirement of states would be addressed.
  - (iii) The transmission corridor which will be developed to connect Railways directly to ISTS substations would be redundant for Railways only and other constituents cannot utilize these lines. However, in present scenario getting another transmission corridor is a difficult task and corridors of railways will be underutilized which would also be a national wastage of public money.
  - (iv) States of eastern region felt that the issue should not be discussed in SCM without resolving the STU issues in lower forums of the ERPC.
- 9.6 Representative of Railways stated that, in case railways is connected to ISTS substations, existing network of STU with railways would be kept free and states may utilise this network for whatever purposes they require. He added that Railways has done economic analysis for some other routes and the report indicates that ISTS connectivity for railways would be economical and reliable. He informed that for Mughalsarai - Howrah route, feasibility study would be submitted to CEA and Niti Aayog..
- 9.7 In regard to query raised by ERLDC regarding source of power through ISTS connectivity, Director, Railways stated that they have 1000MW power plant of BRBCL (Nabinagar-I: 4x250MW) at Nabinagar in Bihar. The first unit of BRBCL is under operation and second unit would be commissioned shortly. He further added that Railways is also planning to tie up with some other generators.
- 9.8 Director, Railways stated that there are two types of proposal from railways:
- (i) Disconnection from existing STU network and connection with ISTS network and



- (j) Dedicated Freight Corridor, which is a new route where ISTS connectivity is required.
- 9.9 Representative of Odisha stated that at present Railways are getting power from 29 different Sub-stations of Odisha. Further, Railways requested for another 21 no. of substations, some of them are under execution and remaining are under process. He added that if railways would be connected to ISTS, utilization of these substations are questionable. He further added that in some areas Railways are requesting for early commission of these substations.
- 9.10 Director, Railways stated that presently entire routes of railways are not planned to be connected with ISTS. Presently, Railways are planning for ISTS connectivity in major trunk routes (6 routes) including golden quadrilateral routes.
- 9.11 Representative of Odisha stated that after these major trunk routes, Railways may plan for other routes also. He added that Railways are constructing lines as a transmission licensee and in some cases they are treated as bulk consumers. This creates confusion for the state utilities whether railways has to be considered as distribution licensee or transmission licensee or bulk consumer. Railways may explain these issues. He requested that Railways has to discuss their plan with individual states and then only they can approach in Standing Committee Meeting.
- 9.12 Representative of BSPTCL stated that states are paying for the ISTS network. In case Railways utilizes this ISTS network, railways would only utilize the space, bays and transmission lines at those points and there would be no further space to meet the load growth of states. In case, Railways utilizes space for 220 kV bays at Arah, Patna, Gaya etc. then there would be no space to meet the load growth of Bihar. He stated that load of Railways TSS would be around 80-100MW at each 220kV point and this would lead to underutilization of bays/lines/space at each ISTS point and thus it is not an optimal planning as per Electricity Act. He added that there is also a confusion whether Railways is to be considered as distribution licensee or transmission licensee or bulk consumer.
- 9.13 Member (Power System), CEA stated that similar observations were made by the states in the Standing Committee Meeting of Northern Region. He suggested that a separate meeting may be planned with all states of ER to discuss the issues of Railways. In that meeting, Railways need to make a presentation on their proposal including economic analysis of the same. The presentation may be shared with all the constituents (CEA, RPCs, CTU, RLDCs, STUs etc.) before the meeting. Additionally, STUs need to send their observations and comments on Railways proposal so that a consolidated list of issues could be prepared and deliberated upon in the meeting.
- 9.14 Members agreed for a separate meeting in regard to railways issues with all constituents.
- 10. Modification in - Common Transmission System for Phase-II generation project in Odisha**
-

- 10.1** Representative of CTU informed that it was suggested to review the installation of 765/400kV, 2x1500MVA ICTs at Angul S/s in view of non-materialisation of some of the IPPs envisaged to be connected at Angul substation in the 18<sup>th</sup> ER SCM.
- 10.2 Accordingly, the matter has been reviewed by CTU (POWERGRID) and the following has been observed:
- i) *In view of uncertainty in commissioning of NSL (connectivity cancelled) and Talcher-III (connectivity and LTA applications closed) generation projects and non-materialisation of Navbharat (applicant has filed for relinquishment in CERC) generation project, the installation of 765/400kV, 2x1500MVA ICTS at Angul is not required.*
  - ii) *Accordingly, the spare 765/400kV, 500MVA ICT (single phase unit) at Angul S/s is also not required.*
  - iii) *The bus splitting at Angul at both 400kV and 765kV levels is not required at present as the fault level at Angul is found to be within rated limits.*
  - iv) *The split bus arrangement may be implemented in future under a different scheme after firming of generation projects near Angul.*
  - v) *The spare 765/400kV, 500MVA ICT (single phase unit) at Sundargarh (Jharsuguda) S/s is not required.*
- 10.3 In view of the above, following elements are proposed to be deleted from POWERGRID's scope under the scheme – “Common Transmission System for Phase-2 Generation Projects in Odisha”:
- (i) 2x1500MVA, 765/400kV ICTs at Angul S/s along with associated bays
  - (ii) Split Bus Arrangement at Angul S/s at 765kV & 400kV buses
  - (iii) 500MVA, 765/400kV single phase spare ICT unit each at Angul and Sundargarh (Jharsuguda) substations
- 10.4 Members agreed to delete elements mentioned at 10.3 from POWERGRID's scope under the scheme – “Common Transmission System for Phase-2 Generation Projects in Odisha”.
- 11. Termination of 220kV side of 400/220kV, 500MVA ICT-4 at Biharsharif (POWERGRID) substation under ERSS-XX**
- 11.1 Representative of CTU informed that installation of 400/220kV, 500MVA ICT-4 at Biharsharif (POWERGRID) substation by POWERGRID under ERSS-XX scheme was approved in the 18<sup>th</sup> ER SCM. In this regard, it is to mention that there is no 220kV bus at Biharsharif (POWERGRID) S/s. Accordingly, 220kV side of the existing three ICTs are terminated at 3 220kV bays available at Biharsharif (BSPTCL) S/s which is adjacent to Biharsharif (POWERGRID) S/s. Similarly, for installation of 4<sup>th</sup> 400/220kV ICT, 220kV ICT bay needs to be constructed at Biharsharif (BSPTCL) S/s along with small 220kV interconnecting line section from 220kV ICT bushing to 220kV ICT bay.

- 11.2 Further, he stated that termination of 220kV side of the 400/220kV, 500MVA ICT-4 at 220kV bus of Biharsharif (BSPTCL) S/s and laying of small 220kV interconnecting line section from 220kV ICT bushing to 220kV ICT bay under ERSS-XX is proposed by POWERGRID. This proposal has already been granted in principle approval by CEA.
- 11.3 MS, ERPC stated that BSPTCL had raised the issue of space constraint at control room of 220kV Biharshariff (BSPTCL) S/s for accommodating relay panels of ICT.
- 11.4 Director, BSPTCL stated that officers of POWERGRID visited the site and it has been observed that relay panels could be arranged with slight orientation change.
- 11.5 Members gave post fact approval for the termination of 220kV side of the 400/220kV, 500MVA ICT-4 at 220kV bus of Biharsharif (BSPTCL) S/s and laying of small 220kV interconnecting line section from 220kV ICT bushing to 220kV ICT bay under ERSS-XX as proposed by POWERGRID.
12. **Baharampur (India) – Bheramara (Bangladesh) 2<sup>nd</sup> 400kVD/c line**
- 12.1 Representative of CTU informed that cross border interconnection between India and Bangladesh through Baharampur (India) - Bheramara (Bangladesh) 400kV D/c line along with 500MW HVDC Back-to-Back terminal at Bheramara, was commissioned in Sept 2013. About 500MW of power is being transferred from India to Bangladesh through this link.
- 12.2 Further, he informed that the capacity of Bheramara (Bangladesh) HVDC station is being upgraded from 500MW to 1000MW by Bangladesh. The system strengthening required in the Indian and Bangladesh side for transfer of about 1000MW from India to Bangladesh is already under implementation. In regard to N-1 reliability criteria for 1000MW export to Bangladesh, it was decided that during single circuit outage of Baharampur – Bheramara 400kV D/c line, Bangladesh would restrict/reduce the loading on the operating circuit to the permissible extent with the help of runback control /ramping down facility on the HVDC system.
- 12.3 Therefore, in order to ensure reliable supply of 1000MW power to Bangladesh from Baharampur, it was decided in the 12<sup>th</sup> India-Bangladesh Joint Steering Committee (JSC) meeting ( held on 11<sup>th</sup> Dec 2016), to construct a 2<sup>nd</sup> 400kV D/c transmission line from Baharampur (POWERGRID) to Bheramara (Bangladesh) in matching time frame of 2<sup>nd</sup> 500MW HVDC terminal at Bheramara. Further, in the 12<sup>th</sup> JSC meeting, it was also decided that, the Indian portion of the line may be implemented by POWERGRID and the mechanism of sharing of transmission charges by Bangladesh for Indian portion of this link would be on same principles as for the first Baharampur – Bheramara link. Accordingly, MoP vide letter no. 9/5/2016-Trans-Vol-2 dated 01-03-2017 had granted approval for implementation of Indian portion of Baharampur (India) – Bheramara (Bangladesh) 2<sup>nd</sup> 400kV D/c line along with 2 no. 400kV line bays for termination

of this line at Baharampur S/s (India) through Regulated Tariff Mechanism by POWERGRID.

12.4 Members agreed and noted that Baharampur (India) – Bheramara (Bangladesh) 2<sup>nd</sup> 400kV D/c line (within Indian territory) along with 2 no. 400kV line bays for termination of this line at Baharampur S/s would be executed by POWERGRID through Regulated Tariff Mechanism.

13. **High Capacity India-Bangladesh AC Corridor and Formation of 400kV nodes in NER-ER Corridor**

13.1 Representative of CTU informed that during 6<sup>th</sup> SCM of NER, it was stated that at present ER is connected to NER primarily through 400/220kV Bongaigaon S/s in NER. In case of any eventuality at Bongaigaon S/s, there is no second AC connectivity with NER from NEW grid. Therefore, it was agreed that there is need for 2<sup>nd</sup> 400kV AC node for interconnection with national grid. The same was taken into account while planning new interconnection between India and Bangladesh. The new interconnection between India and Bangladesh has been planned with high capacity AC link (765kV line to be initially operated at 400kV) to interconnect Bangladesh with Eastern Region (ER) and North Eastern Region (NER) of Indian grid. The scheme was discussed in the 11<sup>th</sup> India-Bangladesh JSC/JWG meeting held on 13<sup>th</sup> July 2016. The scheme consists of establishment and interconnection of following substations in NER, ER and Bangladesh.

- **In NER:** In view of space constraint at Bongaigaon S/s and to provide a reliable take off point in NER, it was proposed to establish new 400kV substation (to be upgraded to 765kV level in future) at Bornagar in Assam, about 50km away from Bongaigaon, through LILO of Bongaigaon – Balipara 400kV D/c (quad) line at Bornagar and extension of Alipurduar-Bongaigaon 400kV D/c line to Bornagar substation. Bornagar substation would also act as alternative in-feed to NER in addition to Bongaigaon.
- **In ER:** A new 400kV substation (to be upgraded to 765kV level in future) was proposed as a probable take-off point at Katihar (near Purnea) in ER through LILO of both circuits of Rajarhat-Purnea 400kV D/c line (one circuit via Gokarna and other circuit via Farakka).
- **In Bangladesh:** A new 400/230kV substation at Parbotipur (to be upgraded to 765kV level in future) was proposed for the drawl of power by Bangladesh. The proposed interconnection has been planned to connect Parbotipur in Bangladesh to Katihar in Eastern Region and Bornagar in North Eastern Region through 765kV D/c line (to be initially operated at 400kV) for supply of 500MW power to Bangladesh in Phase-I.

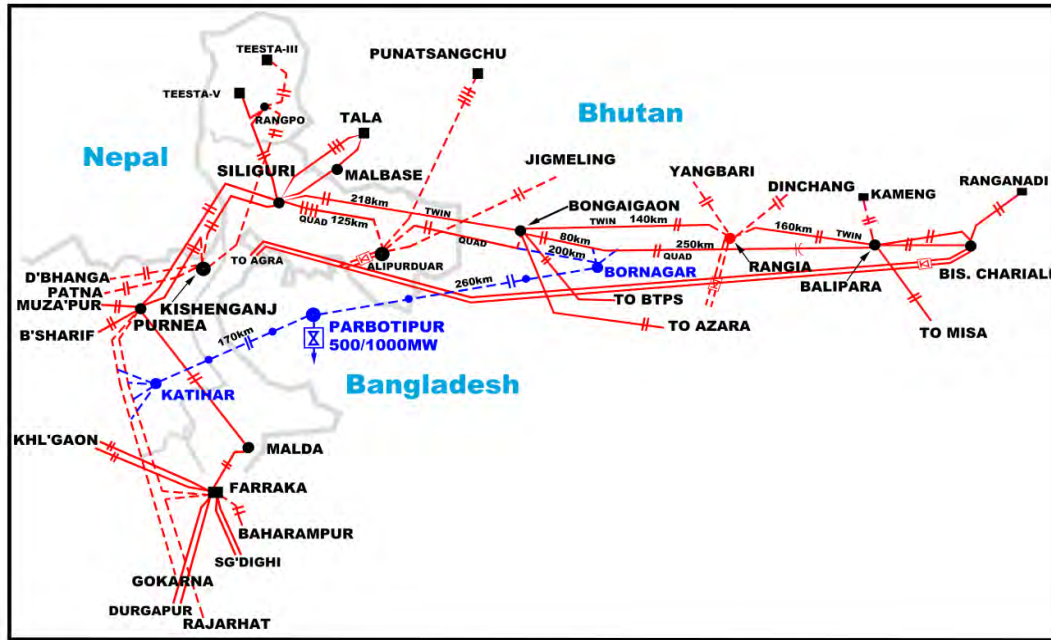

- Bangladesh will draw the power at Parbotipur through HVDC back-to-back.
- In Phase-II, this interconnection would be upgraded to 765kV for transfer of about 1000MW power to Bangladesh along with upgradation of associated AC substations and augmentation of HVDC terminal at Parbotipur with another block of 500MW.
- In the process, Bangladesh would be connected both ER & NER of Indian grid ensuring reliable power supply at Parbotipur.

13.2 Accordingly, the following scope of work is proposed:

#### Phase-I

##### **Indian Side:**

- New 400kV substation (upgradable to 765kV at a later date) at Bornagar (Assam) with LILO of Balipara - Bongaigaon 400kV D/c (quad) line at Bornagar.
- Disconnection of Alipurduar-Bongaigaon 400kV D/c (quad) line from Bongaigaon and extension of the same to Bornagar with 400kV D/C (quad) line so as to form Alipurduar-Bornagar 400kV D/c (quad) line.
- New 400kV substation (upgradable to 765kV at a later date) at Katihar (Bihar) with LILO of both circuits of Purnea - Rajarhat 400kV D/c (triple snowbird) line (one circuit via Gokarna and other circuit via Farakka).

##### **Common:**

- Katihar (ER) - Parbotipur (Bangladesh) - Bornagar (NER) 765kV D/c line to be initially operated at 400KV

##### **Bangladesh Side:**

- 1x500MW, HVDC Back-to-back converter station at Parbotipur

#### Phase-II

##### **Indian Side:**

- Upgradation of Katihar and Bornagar substations from 400kV to 765kV
- Operation of Katihar - Parbotipur - Bornagar 765kV D/c line at its rated voltage
- Other system strengthening in ER and NER (to be identified at alter date)

**Bangladesh Side:**

- Augmentation of HVDC back-to-back substation at Parbotipur (Bangladesh) by another 1x500MW (total 2x500 MW) block
- Upgradation of Parbotipur substation from 400kV to 765kV

13.3 Further, PGCIL stated that detailed scope of works is at **Annexure-13.1**. This scheme has already been discussed and agreed in the 6<sup>th</sup> NER SCM held on 03<sup>rd</sup> Oct 2016 at Imphal. The project report of the above scheme was discussed in the 12<sup>th</sup> India-Bangladesh JWG/JSC meetings held on 10<sup>th</sup>-11<sup>th</sup> Dec 2016, wherein it has been agreed that the modalities of implementation and commercial arrangement etc. need to be worked out by Joint Technical Team (JTT) of India and Bangladesh.

13.4 Director, BSPTCL expressed that, in case new 765/400kV substation established at Katihar with Katihar - Parbotipur – Bornagar 765kV link, 220kV level at Katihar S/s may be created as ISTS to interconnect intra-state network of BSPTCL for improving reliability.

13.5 Chief Engineer(PSPA-2) stated that a separate meeting at CEA may be held regarding creation of 220kV level at proposed 765/400kV Katihar sub-station based on load growth at Katihar. He further added that ,in case 220kV level at Katihar sub-station is required, the same may be created in the matching time frame of Katihar - Parbotipur - Bornagar 765kV link.

13.6 With regard to requirement of OPGW, POWERGRID representative mentioned following points:

- **LILO of 400kV D/c Bongaigaon-Balipara (Quad) at 400kV Bornagar:** To provide OPGW connectivity to Bornagar, 330km of OPGW(24 Fibre) along with communication equipment is proposed to be laid on main line i.e. 400kV D/C Bongaigaon-Balipara (Quad) along with STM-16 communication equipments at 400kV Bongaigaon and Balipara S/s by POWERGRID.
- **LILO of both ckts of 400 KV Purnea – Rajarhat at 400 KV Katihar S/s:** To provide OPGW connectivity to 400kV Katihar S/s, 172km of OPGW(24 Fibre) along with associated communication equipment to be installed on Farakka - Purnea section by POWERGRID. OPGW is being laid on Rajarhat-Farakka (347km) section including LILO at Gokarna.

13.7 Members agreed for followings:

- (a) High Capacity India-Bangladesh AC Corridor through Katihar - Parbotipur - Bornagar 765kV D/c line (scope mentioned at para 13.2).
- (b) A separate meeting at CEA regarding creation of 220kV level at proposed 765/400kV Katihar sub-station based on load growth at Katihar. Members

agreed further that, in case 220kV level at Katihar sub-station as ISTS is required, the same may be created in the matching time frame of Katihar - Parbotipur - Bornagar 765kV link.

**14. Additional power supply to Nepal through Muzaffarpur-Dhalkebar transmission line**

14.1 Director (PSPA-2), CEA informed that Muzaffarpur-Dhalkebar 400kV D/c line is being operated at 132kV in view of non-readiness of 220kV level at Dhalkebar by Nepal. For 132kV operation of the line and supply of about 80MW power to Nepal, one 100MVA, 220/132kV ICT was installed at Muzaffarpur by POWERGRID as an interim arrangement. In view of low hydro scenario in Nepal in winters, Govt. of Nepal requested for installation of 2<sup>nd</sup> 220/132kV, 100MVA ICT at Muzaffarpur for additional power supply.

14.2 Further, she stated that a meeting was held at CEA on 02-12-2016, wherein installation of 2<sup>nd</sup> 220/132kV, 100MVA ICT at Muzaffarpur (spare ICT obtained after replacement of ICT at Purnea) by POWERGRID as a goodwill gesture for supply of about 145MW power to Nepal was agreed with following SPS settings at Muzaffarpur S/s:

- *The power supply to Nepal would be disconnected by opening Muzaffarpur – Dhalkebar 132kV line in case,*

*(a) The power flow through any of the 400/220kV transformers (2x315 + 1x500MVA) at Muzaffarpur exceeds more than 310MW (for 315MVA) and 490MW (for 500MVA).*

**Or**

*(b) If power flow through Muzaffarpur – Dhalkebar 132kV line is more than 140MW.*

- *There is no disruption of power supply to Bihar through the Muzaffarpur S/s.*

14.3 Representative of CTU informed that ICT has already been installed by POWERGRID and upto 145MW (170MVA) power is being supplied to Nepal through the cross-border link. Loading beyond 140MW (160MVA) upto 145MW (170MVA) would be allowed only for five minutes. Beyond 145MW (170MW), the cross-border link would be instantaneously tripped.

14.4 Representative of CTU stated that 220kV operation of the link is expected in the end of January 2018 subject to readiness of 220kV level at Dhalkebar by Nepal. After this the spare 220/132kV, 2x100MVA ICTs at Muzaffarpur could be released.

14.5 Members agreed for post facto approval for utilisation of 220/132kV, 100MVA ICT released from Purnea for installation at Muzaffarpur (for supply of additional power to Nepal), till operation of Muzaffarpur – Dhalkebar line at 220kV.

**15. Modification in - Transmission System for Transfer of power from generation projects in Sikkim to NR/WR (Part-B1)**

- 15.1 Representative of CTU informed that it was decided to delink the LILO of 2<sup>nd</sup> circuit of Teesta-III – Kishanganj 400kV D/c (Quad) line at Rangpo from Part-B of the scheme “Transmission System for Transfer of power from generation projects in Sikkim to NR/WR (Part-B)” and take it up as a separate part (Part-B1) of the same scheme as “Transmission System for Transfer of power from generation projects in Sikkim to NR/WR (Part-B1)” in the 18<sup>th</sup> ER SCM. LILO of first circuit of Teesta-III – Kishanganj 400kV D/c (Quad) line at Rangpo has been made using HTLS conductor. Accordingly, keeping in view the anticipated problems in construction due to hilly terrain as well as requirement of land for foundation, construction of 2<sup>nd</sup> LILO line with HTLS would be a better techno-commercial solution.
- 15.2 Further, he stated that the two 400kV LILO lines are being constructed on two separate D/c towers, however, in view of RoW constraints near Rangpo the two LILO lines are proposed to be terminated on a Multi Circuit tower at Rangpo end. Multi circuit has been considered along with LILO of first circuit. In view of the above, members may approve the following:
- (i) LILO of 2<sup>nd</sup> circuit of Teesta III – Kishanganj 400kV D/c (Quad) line at Rangpo with Twin HTLS conductor
  - (ii) 400kV multi circuit tower/line at Rangpo end for termination of LILO of both circuits of Teesta III – Kishanganj 400kV D/c (Quad) line at Rangpo.
- 15.3 Members agreed to the proposal mentioned at 15.2 by POWERGRID.
16. **Interim connectivity to generation projects through LILO arrangement**
- 16.1 Director, CEA informed that numbers of generation projects in different regions were granted Connectivity / Long Term Access (LTA) with strengthening of transmission system. In few cases generation projects were to be commissioned ahead of the anticipated commissioning of the associated transmission system. In such cases, generation projects were given temporary connectivity through loop-in & loop-out (LILO) of nearby transmission lines so as to facilitate connection with the grid and commissioning of their generation projects. The temporary connectivity through LILO was to be withdrawn after commissioning of the associated transmission system. Associated transmission system of some of such generation projects have been commissioned and their temporary connectivity through LILO has been disconnected; however, some are still connected through LILO arrangement.
- 16.2 Further, she stated that after hearing the tariff petition for one such case viz. transmission system associated phase-1 IPPs in Odisha (Petition No.112/TT/13), where two generation projects were connected through temporary LILO arrangement, the Hon'ble CERC had passed the order dated 07.10.15 wherein the following direction was given in para 65 of the order:
- "The associated transmission lines were to be constructed by the generation developer matching with the transmission system to be developed by the petitioner and the LILOs constructed by generation developers which were temporary arrangement were to be*



replaced by the associated transmission system. It is noticed that some of the generation developers have not commissioned the dedicated lines and are continuing to evacuate power through the temporary LILO arrangements. We direct the petitioner to discuss the issue in the Standing Committee Meeting on Transmission and finalize the timeline for replacement of the LILOs of generation developer by dedicated transmission lines within a period of six months from the date of connection of LILO of the petitioner."

- 16.3** Further, CERC in its order dated 28-09-2016 in Petition no. 30/MP/2014 has directed that:

*"CTU shall take up all the existing cases of connectivity on interim LILO with the RPC of respective regions within a period of one month from the date of issue of this order for review and decision on disconnection of the interim arrangements through LILO. All such interim arrangements through LILO shall be disconnected within a period of three months of the issue of this order unless the RPC grants extension for continuation of LILO keeping in view of all relevant factors."*

- 16.4** Further, representative of CTU informed that the progress of dedicated transmission lines of IPPs in Eastern Region, which were connected through interim arrangement, was reviewed in the 18<sup>th</sup> SCM of ER on 13-06-2016 and subsequently in the 34<sup>th</sup> and 35<sup>th</sup> TCC/ERPC meetings held on 19-11-2016 and 25-02-2017 respectively. The latest status of the dedicated transmission lines as reported by IPPs in recent meetings is summarized below:

Generation Project in ER connected through temporary LILO arrangement					
Sl. No.	Generation Project	Installed Capacity (in MW)	Present Connectivity through LILO	Final Connectivity Arrangement (not commissioned)	Anticipated Completion Schedule
1	Vedanta Ltd. (Sterlite Energy Ltd.)	4x600	LILO of one circuit of Rourkela - Raigarh 400kV D/c line (granted in Sept'09)	Sterlite - Jharsuguda 400kV 2xD/c	15-04-2017 (as per 35 <sup>th</sup> TCC/ERPC)
2	Ind Barath Energy (Utkal) Ltd.	2x350	LILO of one circuit of Jharsuguda - Raigarh 400kV D/c line (granted in Sept'09)	Ind Barath - Jharsuguda 400kV D/c	LILO opened on 11-03-2017. The project is currently not connected to the Grid and IBEUL has placed order to increase the tower heights at 4 locations which shall be completed by Jun'17.
3	Gati Infrastructure Ltd. (Chuzachen)	2X49.5	LILO of Rangpo - Melli 132kV S/c line (granted in Nov'07)	Chuzachen - Rangpo 132kV D/c (with Zebra conductor)	Line completed. Commissioned on interim arrangement. Line bays by Govt. of Sikkim at Rangpo end are expected by Dec 2017 (as per 35 <sup>th</sup> TCC/ERPC)
4	Sneha Kinetic Power Projects Pvt. Ltd. (Dikchu)	2x48	LILO of one circuit of Teesta-III - Rangpo 400kV D/c line at Dikchu (granted in Dec'14 by CERC)	Dikchu - Dikchu Pool 132kV D/c	( <sup>8</sup> )To be informed by Sikkim and project developer

(<sup>8</sup>) Dikchu Pool S/s is being implemented under Sikkim Comprehensive Scheme of Govt. of Sikkim (being implemented by POWERGRID on consultancy). The expected commissioning schedule of Dikchu Pool S/s and Dikchu - Dikchu Pool 132kV D/c line needs to be informed by Govt. of Sikkim and project developer respectively.

- 16.5 MS, ERPC stated that Vedanta Ltd. had informed that only 0.8 km line is left for completion. In last OCC meeting of ERPC, Vedanta had requested for additional 10-15 days to complete the work. This line may be commissioned at the end of this September 2017.
- 16.6 Regarding Ind-Bharat – Jharsuguda 400kV line, MS, ERPC informed that conditional approval has been granted to Ind-Bharat by Electrical Inspectorate, because of not having sufficient clearance at Railway crossing. He stated that Chief Electrical Inspector to Gol informed that this conditional approval has been extended for two more months.
- 16.7 Regarding Chuzachen of Gati Infrastructure Ltd., representative of Sikkim Government stated that line bays would be completed by the end of March 2018.
- 16.8 Regarding Dikchu of Sneha Kinetic Power Projects Private Ltd., CTU intimated that POWERGRID is working as a consultant for Sikkim Comprehensive Scheme which inter alia includes construction of Dikchu Pool S/s and Dikchu Pool – Samardong/Rangpo line. Dikchu HEP final connectivity has been planned as Dikchu generation switchyard to Dikchu pool line to be constructed by generation project developer. Dikchu pool to Samardong/Rangpo line might be commissioned by Sept 2018 and Dikchu pool substation might be commissioned by May 2019. Sneha Kinetic Power Projects Private Ltd. needs to construct Dikchu generation switchyard - Dikchu pool 132kV D/c line along with associated bays at both ends in matching time-frame.
- 16.9 Updated status of above mentioned LILOs are noted by the members.
- 17. Status of downstream 220kV or 132kV network by STUs from the various commissioned and under-construction ISTS substations**
- 17.1 Representative of CTU informed that various ISTS sub-stations have been commissioned/expected to be commissioned shortly (under construction) for which the down stream linking system is being implemented by STUs. Following downstream network along with expected commissioning schedule was informed by STUs in the meeting(s):

**A. Existing substations**

**(a) Chaibasa 400/220kV S/s**

- (i) Chaibasa (POWERGRID) – Chaibasa (JUSNL) 220kV D/c – **Commissioned**
- (ii) Chaibasa (POWERGRID) – Ramchandrapur 220kV D/c – **status could not be updated due to absence of representative from JUSNL**

**(b) Bolangir 400/220kV S/s**

- (i) LILO of one ckt of Sadeipalli – Kesinga 220kV D/c at Bolangir – **Dec'17**
- (ii) LILO of one ckt of Katapalli – Sadeipalli 220kV D/c at Bolangir – **Commissioned**

**(c) Keonjhar 400/220kV S/s**

- (i) Keonjhar (POWERGRID) – Keonjhar (OPTCL) 220kV D/c – **Dec'17**
- (ii) Keonjhar (POWERGRID) – Turumunga (OPTCL) 220kV D/c – **Mar'19**

**(d) Pandiabil 400/220kV S/s**

- (i) Pratapsasan (OPTCL) – Pandiabil (POWERGRID) 220kV D/c – **Dec'17**
- (ii) LILO of both circuits of Atri – Puri (Samangara) 220kV D/c line at Pandiabil (POWERGRID) – **Commissioned**

**(e) Alipurduar 400/220kV S/s**

- (i) Alipurduar (POWERGRID) – Alipurduar (State) 220kV D/c – **Sep'17**

**(f) Subashgram 400/220kV S/s**

- (i) Subashgram – Baraipur 220kV D/c line – **Dec'18**

**(g) Darbhanga 400/220kV S/s**

- (i) Darbhanga (ISTS) – Darbhanga (BSPTCL) 220kV D/c – **Dec'17**
- (ii) Darbhanga (ISTS) – Motipur 220kV D/c – **Commissioned**
- (iii) Darbhanga (ISTS) – Samastipur New 220kV D/c (S/c strung) – **Commissioned**
- (iv) Darbhanga (ISTS) – Laukhi (earlier Supaul New) 220kV D/c – **Dec'17**

**B. Under Construction substations**

**(h) Daltonganj 400/220/132kV S/s: Expected by Dec'17**

***Status of following lines could not be updated due to absence of representative from JUSNL***

- (i) Daltonganj (POWERGRID) – Latehar 220kV D/c
- (ii) Daltonganj (POWERGRID) – Garhwa 220kV D/c
- (iii) Daltonganj (POWERGRID) – Daltonganj (JUSNL) 132kV D/c
- (iv) Daltonganj (POWERGRID) – Chatarpur/Lesliganj 132kV D/c

**(i) Rajarhat 400/220kV S/s: Expected by Sept'17**

- (i) Rajarhat – New Town AA3 220kV D/c – **Sept'17**
- (ii) Rajarhat – New Town AA2 220kV D/c – **Oct'18**
- (iii) Rajarhat – Barasat 220kV D/c – **Jun'18**

**(j) Motihari 400/132kV S/s: Expected by 15<sup>th</sup> July 2017**

- (i) Motihari (ISTS) – Motihari (BSPTCL) 132kV D/c – **Completed.**
- (ii) Motihari (ISTS) – Betiah 132kV D/c – **Completed.**
- (iii) Motihari (ISTS) – Raxaul 132kV D/c – **Oct'17**

**(k) Dhanbad 400/220kV S/s: May'19**

- (i) Dhanbad – Jainamore 220 kV D/c – ***status could not be updated due to absence of representative from JUSNL***
- (i)
- (ii) Dhanbad – Govindpur 220 kV D/c – ***status could not be updated due to absence of representative from JUSNL***

17.2 No representative from JUSNL was present in the meeting. Accordingly, it was decided that JUSNL may communicate CEA updating on the status of downstream network being implemented by state.

**18. Connectivity and LTA application of Odisha Integrated Power Ltd. (Odisha UMPP) and transmission system for power evacuation**

18.1 Representative of CTU stated that the 4000MW Connectivity and LTA applications for Odisha UMPP submitted by Odisha Integrated Power Ltd.(OIPL), wholly owned subsidiary of PFCL, are pending since long (June'14) on account of non-firming of generation project implementation. In this regard, it is to mention that CERC vide Amendment dated 17-02-2016 has directed CTU not to hold any application in abeyance and process them within the timeline prescribed in Regulation 7 of the Connectivity Regulations.

18.2 He (CTU) further added that the transmission system for Odisha UMPP was discussed in the 17<sup>th</sup> ER-SCM held on 25-05-2015, wherein it was decided to discuss the transmission system when the implementation of the generation project is firmed up. The said applications were also discussed in the 11<sup>th</sup> Connectivity and LTA meeting of ER held on 13.06.2016 wherein OIPL informed the commissioning schedule of Odisha UMPP as 2021-22 and it was decided that CEA shall convene a meeting to finalise the transmission system for Odisha UMPP. Subsequently, in association with CEA, various transmission system alternatives have been studied by CTU and a study report in this regard is enclosed at **Annexure-18.1**. As per the study report, following transmission system is proposed for Odisha UMPP:

- Split bus arrangement at Odisha UMPP (3x660MW in Section-A and 3x660MW in Section-B)
- LILO of Sundargarh-A – Dharamjaygarh 765kV D/c line at Odisha UMPP-A

**Or**

- LILO of Sundargarh-A – Raipur Pool 765kV D/c line at Odisha UMPP-A
- Odisha UMPP-B - Sundargarh-B 765kV D/c line
- Ranchi (New) – Gaya 765kV D/c line

18.3 CTU stated that OIPL is required to submit MoP letter regarding allocation of power to various beneficiaries from Odisha UMPP. He further added that OIPL may also confirm the unit size of generation project and commissioning schedule.

18.4 CTU proposed to grant Connectivity and LTA to OIPL for Odisha UMPP project (4000MW) with following transmission system:

**Transmission System for Connectivity:**

- Split bus arrangement at Odisha UMPP with 3x660MW in Section-A and 3x660MW in Section-B. For connectivity of 6X660 MW, bus sectionaliser should be kept closed.

- Odisha UMPP-B – Sundargarh-B 765kV D/c line

### **Transmission System for LTA**

- Split bus arrangement at Odisha UMPP with 3x660MW in Section-A and 3x660MW in Section-B. The bus sectionaliser should be kept normally open.
  - LILO of Sundargarh-A – Dharamjaygarh 765kV D/c line at Odisha UMPP-A
  - Ranchi (New) – Gaya 765kV D/c line
- 18.5 With regard to requirement of OPGW, POWERGRID representative stated that to provide OPGW connectivity to Odisha UMPP-A, 150km of OPGW (24 fibre) and associated communication equipment is to be installed on 765kV D/C Sundargarh-A – Dharamjaygarh line and respective terminal substations respectively by POWERGRID.
- 18.6 Representative of CTU stated that OIPL/beneficiaries need to sign requisite agreements for grant of Connectivity and LTA for taking up the evacuation system for implementation, failing which the Connectivity and LTA intimations shall be liable for closure/cancellation.
- 18.7 Members agreed for following system proposed for evacuation of Odisha UMPP generation(4000MW) :
- a. Split bus arrangement at Odisha UMPP (3x660MW in Section-A and 3x660MW in Section-B)
  - b. LILO of Sundargarh-A – Dharamjaygarh 765kV D/c line at Odisha UMPP-A
  - c. Odisha UMPP-B - Sundargarh-B 765kV D/c line
  - d. Ranchi (New) – Gaya 765kV D/c line
19. **Additional feed to southern Odisha to improve power supply reliability and enable maximum utilisation of Guzuwaka Back-to-Back HVDC**
- 19.1 Representative of CTU informed that, in the 18<sup>th</sup> SCM of ER it was noted that in absence of Talcher – Behrampur – Gazuwaka 400kV D/c line by M/s Reliance under TBCB, power flow though Gazuwaka 2x500MW HVDC is restricted under Low Hydro scenario in southern Odisha. Accordingly, it was decided that an additional scheme independent of Talcher – Behrampur – Gazuwaka may be planned and if in future Talcher – Behrampur – Gazuwaka 400kV D/c line is implemented, it would give additional strength to the southern Odisha transmission system and would also improve the low voltage problem in the area.
- 19.2 Accordingly, a meeting was held at CEA on 30-06-2016 with CTU (POWERGRID) and OPTCL wherein following ISTS scheme was identified as an additional transmission system to improve reliability of power supply to southern Odisha and also to enable maximum utilisation of Guzuwaka Back-to-Back HVDC:
- (a) Angul – Narendrapur (New) 400kV D/c (Triple Snowbird) line

(b) Narendrapur (New) – Gazuwaka 400kV D/c (Triple Snowbird) line

19.3 The deliberation on this issue is available at item No. 36 of this minutes.

20. **Proposal for stepwise completion of Rajarhat – New Purnea 400kV D/c line under ERSS-V scheme**

20.1 Representative of POWERGRID has informed that major transmission system under ERSS-V scheme is Rajarhat – New Purnea 400kV D/c (Triple Snowbird) line with LILo of one circuit at Gokarna (WBSETCL) and other circuit at Farakka (NTPC). The construction work of 400/220kV GIS substation and 400kV transmission lines at Rajarhat end has been completely brought to a standstill condition due to agitation by local villagers. The West Bengal state administration has advised POWERGRID to stop construction activities at and near Rajarhat substation till further instructions.

20.2 Further, he informed that it is likely that Rajarhat – Farakka transmission line at Rajarhat end may not be completed within FY 2016-17 due to volatile political situation. However, Farakka – Gokarna portion of the said line along with associated bays at Farakka has been completed. Further, substation works at Gokarna viz. ICT (under scope of WBSETCL) and 400kV line bays including 80MVAR bus reactor (under scope of POWERGRID) have also been commissioned. Accordingly, after approval from ERPC the Farakka – Gokarna portion of Rajarhat – New Purnea line has been commissioned. Commissioning of Farakka – Gokarna portion has established connection of Gokarna substation at 400kV level with ISTS enabling improvement of power situation in and around Gokarna and Baharampur area.

20.3 In view of the above facts, the Rajarhat – New Purnea line is further proposed to be commissioned in steps as detailed below:

Sl. No.	Charging of elements
1	Farakka – Gokarna 400kV D/c portion of the Rajarhat – New Purnea line (including sections of LILo of one circuit of Rajarhat – New Purnea line at Farakka & other circuit at Gokarna) along with 80MVA <sub>r</sub> bus reactor at Gokarna and 80MVA <sub>r</sub> switchable line reactor at Farakka end: <b>Commissioned</b>
2	Rajarhat – Gokarna 400kV D/c portion of the Rajarhat – New Purnea line (resulting in formation of Farakka – Rajarhat and Farakka – Gokarna – Rajarhat 400kV S/c lines)
3	Farakka – New Purnea 400kV D/c portion of the Rajarhat – New Purnea line (resulting in formation of planned lines viz. New Purnea – Farakka – Rajarhat and New Purnea – Gokarna – Rajarhat 400kV S/c lines)

The schematic of Rajarhat – New Purnea line is shown below:

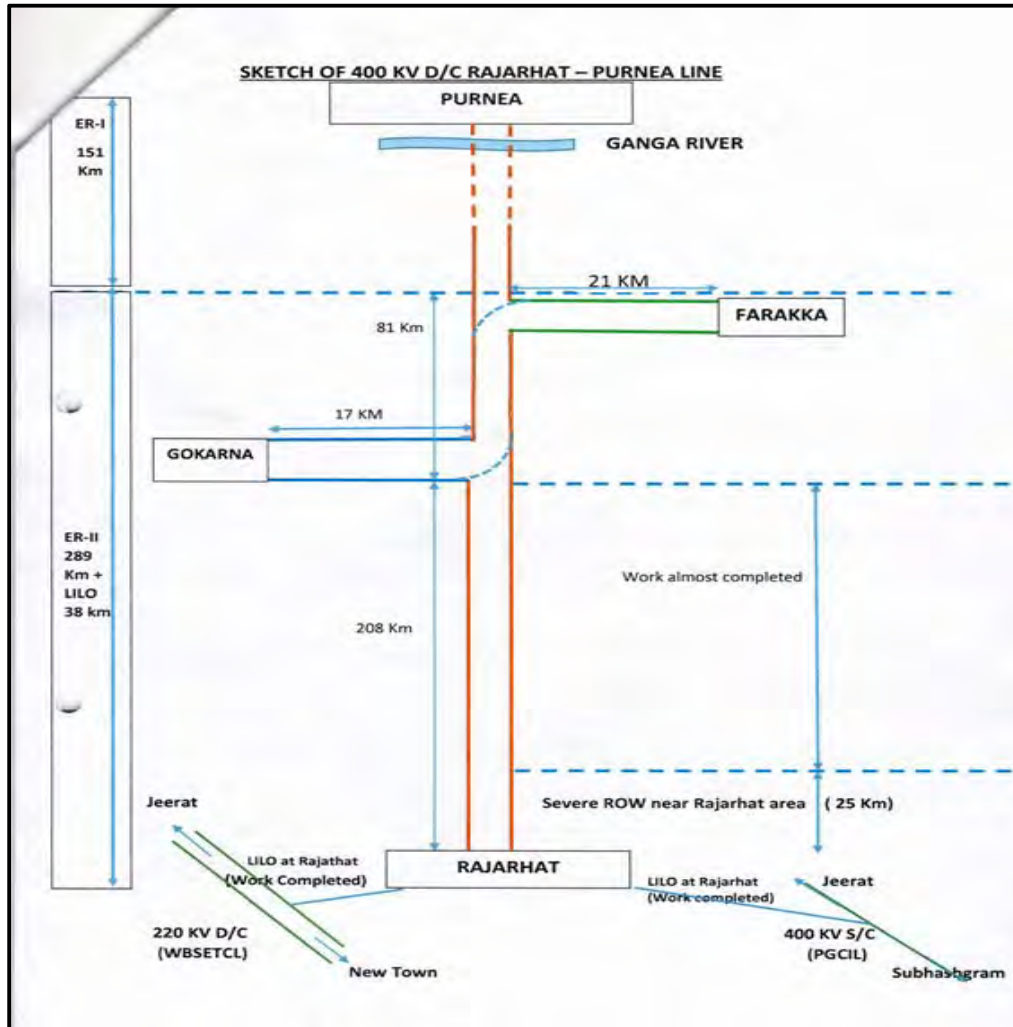

- 20.4 Farakka – Gokarna 400kV D/c section of the line has already been charged.
- 20.5 Members agreed for the step wise commissioning of elements mentioned at para 20.3.
- 21. Programme for 11<sup>th</sup>/12<sup>th</sup> Plan augmentation of DVC System- Submission of revised plan for approval**
- 21.1 Representative of DVC informed that a 220kV new substation was approved at Gola in Jharkhand with 220kV D/c lines connecting the new Gola S/s to Ramgarh (DVC), MTPS (DVC) and Ranchi (POWERGRID) substations in 11<sup>th</sup>/12<sup>th</sup> Plan for network augmentation of DVC system. Due to financial crunch and restriction imposed by MoP on investment in respect of DVC transmission system, the construction of new 220kV substation at Gola has been dropped by DVC. The above mentioned 220kV lines (proposed connecting Gola S/s with Ramgarh & MTPS substations of DVC and Ranchi-POWERGRID S/s) are complete/nearing completion. To utilize the upcoming 220kV lines to the best extent possible, a revised plan is proposed bypassing the Gola S/s.

- 21.2 DVC also informed vide its e-mail dated 10.04.2017 that load growth at Gola would be met by installation of third 31.5 MVA, 132/33kV power transformer in 132/33kV Gola substation.
- 21.3 Members agreed to drop 220kV substation of DVC at Gola(New) and approved the revised plan of 220kV D/c connectivity of Ramgarh (DVC) — Ranchi (POWERGRID)– MTPS (DVC)- Ramgarh (DVC) lines as shown below:

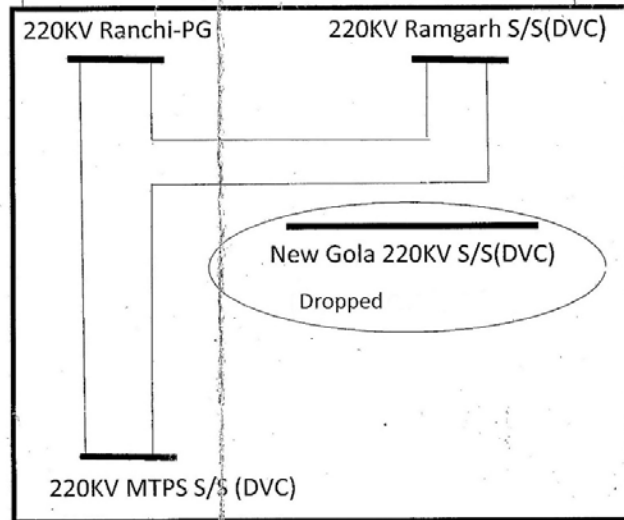

## 22. Installation of bus reactors at 400kV level at substations of STU

- 22.1 Representative of CTU informed that following 400kV intra-state substations were approved for implementation by respective STUs of Bihar and Odisha in the 18<sup>th</sup> ER Standing Committee Meeting:

### 22.1.1.1 Bihar (to be implemented by BSPTCL)

- (i) 400/220/132/33kV GIS S/s at Naubatpur (2x500MVA 400/220kV +2x160MVA 220/132kV +2x80MVA 132/33Kv)
- (ii) 400/220/132kV GIS S/S at Bakhtiyarpur (2x500MVA 400/220kV+2x160MVA 220/132Kv)
- (iii) 400/220/132/33kV GIS S/s at Jakkanpur (2x500MVA 400/220kV +3x160MVA 220/132kV +4x80MVA 132/33Kv)

### 22.1.1.2 Odisha (to be implemented by OPTCL)

- (i) 400/220kV sub-station at Meramundali-B (2x500MVA)
- (ii) 400/220kV sub-station at Narendrapur (New) (2x500MVA)
- (iii) 400/220kV sub-station at Khuntuni (2x500MVA)

- 22.2 Further, he informed that at the above mentioned 400kV intra-state substations no bus reactors have been planned by BSPTCL and OPTCL. In order to keep operational flexibility/control over voltages, it was suggested to install suitable bus reactors at 400kV levels in STU system in line with ISTS system. Accordingly OPTCL and BSPTCL may install 420kV, 2x125MVAr bus reactors at above



planned substations except Narendrapur (New) where 420kV, 2x80MVA<sub>r</sub> may be installed.

- 22.3 OPTCL in principle agreed to the proposal and informed that keeping two reactors at each substation to meet N-1 criterion will not be economical.
- 22.4 OPTCL added that based on detailed study, they are installing one reactor at each 400kV substations. OPTCL placed the details as follows:
- One 420kV, 125MVA<sub>r</sub> bus reactor each at Meramundali, Mendhasal and New Duburi
  - One 420kV, 80MVA<sub>r</sub> bus reactor each at Meramundali-B, Khuntuni and Narendrapur
- 22.5 BSPTCL agreed to the proposal of installation of 420kV, 2x125MVA<sub>r</sub> bus reactors under intra-state scheme at their Naubatpur, Bakhtiyarpur and Jakkanpur substations.
- 22.6 Members agreed for the proposal of BSPTCL & OPTCL.

**23. Constraint in transportation of ICT to Farakka (NTPC) under ERSS-XII**

- 23.1 Representative of POWERGRID informed that replacement of 400/220kV, 2x315MVA ICTs with 400/220kV, 2x500MVA ICTs was approved at Patna, New Purnea and Sasaram (Pusauli) substations in the 15<sup>th</sup> ER Standing Committee Meeting held on 27-08-2013. Therein, it was also decided to install one of the 315MVA ICT released from Patna/New Purnea/Sasaram at Farakka generation switchyard as 2<sup>nd</sup> ICT by POWERGRID. The said scopes are being implemented by POWERGRID as part of ERSS-XII scheme. One 400/220kV, 315MVA ICT released from Sasaram (Pusauli) was identified for installation at Farakka.
- 23.2 Further, he informed that the 400kV & 220kV switchyard equipment and Control & Relay equipment associated with installation of 400/220kV ICT are in place at Farakka. While in transit the main ICT tank was stopped by CISF at Farakka Barrage Project (under Ministry of Water Resources). POWERGRID vide letter dated 19-08-2016 requested permission from Farakka Barrage Project for transportation of the ICT. However, the Barrage Authority vide letter dated 05-09-2016 denied permission for the same. Subsequently, POWERGRID approached the Secretary, Ministry of Water Resources (apex body for Farakka Barrage Project) on 08-09-2016. However, the Ministry of Water Resources declined permission vide their letter dated 23-09-2016 and requested POWERGRID to explore for alternate routes. Previously, all other consignments were transported to Farakka generation project through this route only.
- 23.3 Accordingly, POWERGRID explored following alternate routes for transportation of the ICT:

(a) *Via **NEW FARAKKA: A railway underpass (14 ft.) physically prevented the consignment of 17.5 ft. height.***

- (b) Via **DHULIAN-SHANKARPUR**: One intermediate bridge on feeder canal of nearly 500 mtr length is **unfit for movement of even LMV** and is very risky as the condition of the bridge is dilapidated.
- (c) Via **PAKUR – BARHARWA – NTPC FARAKKA**: explored and physically surveyed by POWERGRID & transporter, but found not feasible as **Major civil work are required for construction of road/bypass over bridges/culverts; en-route, for Trailer with such dimension and weight.**
- 23.4 From above it emerges that the ICT can be transported to Farakka only through the road of Farakka Barrage Project, which has been denied by the apex body (Ministry of Water Resources).
- 23.5 Thus with no possible transportation options, the ICT has been diverted and stationed at Durgapur S/s of POWERGRID. In the 18<sup>th</sup> ER Standing Committee Meeting held on 13-06-2016, installation of 3<sup>rd</sup> 400/220kV, 315MVA ICT at Durgapur (ICT-2 released after replacement at New Purnea S/s) was approved. This is being implemented by POWERGRID under ERSS-XVII (Part-B) scheme.
- 23.6 In view of the above mentioned transportation constraints it is proposed that ICT diverted from Sasaram S/s (identified for installation at Farakka under ERSS-XII) may be installed at Durgapur S/s as 3<sup>rd</sup> ICT (under ERSS-XVII Part-B).
- 23.7 Further, he stated that the following modifications in the scope of ERSS-XII and ERSS-XVII (Part-B) schemes are proposed:
- (a) Deletion of scope of installation of Sasaram (Pusauli) 400/220kV, 315MVA ICT-2 as 2<sup>nd</sup> 400/220kV, 315MVA ICT at Farakka generation switchyard from ERSS-XII scheme.
- (b) Modification in ERSS-XVII (Part-B) scheme: Installation of above mentioned Pusauli 400/220kV, 315MVA ICT-2 as 3<sup>rd</sup> 400/220kV, 315MVA ICT at Durgapur instead of earlier approved New Purnea 400/220kV, 315MVA ICT-2.
- (c) Shifting of New Purnea (ICT-2) to Durgapur under ERSS-XVII (Part-B) scheme is not required; hence the same may be kept as spare ICT at New Purnea itself.
- 23.8 Representative of ERLDC stated that there is only one ICT at Farakka NTPC, in case of any maintenance or repair of transformer, the power supply would be interrupted
- 23.9 Member (Power System), CEA stated that additional ICT requirement at Farakka is based on the load flow study and for fulfilling N-1 criteria. He queried regarding alternative routes to transport the ICT to Farakka.
- 23.10 Representative of POWERGRID stated that the option left for transportation of ICT to Farakka is through water ways only, i.e. through Farakka feeder canal. Transportation of the ICT through this option may incur an additional cost of about ₹ 4 Cr.

- 23.11 Representative of ERPC stated that the constituents are ready to bear the transportation cost as this is a technical requirement.
- 23.12 In view of the above, members agreed to the following modifications in the already under implementation ERSS-XII and ERSS-XVII (Part-B) schemes of POWERGRID:
- (a) Deletion of scope of installation of Sasaram (Pusauli) 400/220kV, 315MVA ICT-1 (released after replacement) as 2nd 400/220kV, 315MVA ICT at Farakka generation switchyard from ERSS-XII scheme.
  - (b) Installation of above mentioned Sasaram (Pusauli) 400/220kV, 315MVA ICT-1 (released after replacement) as 3rd 400/220kV, 315MVA ICT at Durgapur under ERSS-XVII (Part-B) instead of earlier approved New Purnea 400/220kV, 315MVA ICT-2 (released after replacement).
  - (c) Installation of New Purnea 400/220kV, 315MVA ICT-2 (released after replacement) as 2nd 400/220kV, 315MVA ICT at Farakka generation switchyard under ERSS-XII instead of earlier approved Sasaram (Pusauli) 400/220kV, 315MVA ICT-1. In case of transportation constraints to Farakka switchyard, the ICT may be transported through Farakka feeder canal waterways at additional cost under ERSS-XII scheme.
24. **Conversion of 50MVAR (3x16.67MVAR) bus reactor at Farakka to switchable line reactor under the ERSS-XV due to space constraints in termination of Farakka – Baharampur 400kV D/c (Twin HTLS) line**
- 24.1 Representative of POWERGRID has informed that ERSS-XV scheme inter alia includes construction of Farakka – Baharampur 400kV D/c (Twin HTLS) line. One spare future bay has been selected for termination of one circuit of Farakka – Baharampur D/c line at 400kV bus at Farakka generation switchyard, however, due to non-availability of adjacent bay for termination of the other circuit it is proposed to terminate the second circuit in the existing 50MVAR bus reactor bay along with conversion of this reactor to switchable line reactor. This arrangement would result in connection of 50MVAR switchable line reactor in one circuit of Farakka – Baharampur 400kV D/c line at Farakka end to be utilised as bus reactor.
- 24.2 Representative of ERLDC stated that Farakka is having high voltage problem therefore, the reactor is required.
- 24.3 Members agreed for conversion of 50MVAR (3x16.67 MVAR) bus reactor at Farakka to switchable line reactor to be installed in one circuit of Farakka – Baharampur 400kV D/c line as ISTS.
25. **Modification in transmission system required for power evacuation from Sikkim IPPs and Operationalization of LTA**
- 25.1 Representative of CTU informed that for following seven IPPs envisaged under Phase-1 in Sikkim, the High Capacity Power Transmission Corridor-III was planned:

Sl. No.	Name of the Developer/ Open Access Applicant	Commissioning Schedule (as per 13 <sup>th</sup> JCC)	Installed Capacity (MW)	LTOA Quantum (MW)
1	Teesta Urja Ltd. / PTC (Teesta-III)	Commissioned	1200 (6x200)	1200
2	Lanco Energy Pvt. Ltd. (Teesta-VI)	U-1: Jul'20, U-2: Aug'20 U-3 & 4: Sept'20	500 (4x125)	500
3	DANS Energy Pvt. Ltd. (Jorethang)	Commissioned	96 (2x48)	96
4	JAL Power Corporation (Rangit-IV)	U-1: Feb'21 U-2 & 3: Mar'21	120 (3x40)	120
5	Madhya Bharat Power Corporation Ltd. (Rongnichu)	U-1: Nov'18 U-2: Dec'18	96 (2x48)	96
6	Gati Infrastructure Ltd (Chuzachen)	Commissioned	99 (2x49.5)	99
7	Gati Infrastructure Bhasmey Power Pvt. Ltd. (Bhasmey)	Uncertain	51 (2x25.5)	51
		<b>Total</b>	<b>2162</b>	<b>2162</b>

Based on the decisions of various Standing Committee Meetings of ER and Connectivity & LTA meetings of ER, following common transmission system is being implemented under the High Capacity Power Transmission Corridor-III:

• **Substation**

- (A) Establishment of new 400/220kV, 2x500MVA GIS S/s at Kishanganj
- (B) Establishment of 400/220/132kV (400/220kV, 16x105 MVA, Single Phase transformers and 220/132kV, 3x100MVA) GIS S/s at Rangpo
- (C) Establishment of 220kV GIS switching station at New Melli

• **Transmission Line**

- (D) LILO of Gangtok – Melli 132kV S/c line at Rangpo
- (E) LILO of Gangtok – Rangit 132kV S/c line at Rangpo
- (F) Rangpo – New Melli 220kV D/c line (with single HTLS conductor)
- (G) LILO of Siliguri – Dalkhola 220kV D/c line at Kishanganj
- (H) LILO of New Siliguri – New Purnea 400kV D/c line (quad) at Kishanganj
- (I) LILO of Teesta V – Siliguri 400kV D/c line at Rangpo
- (J) Kishanganj – Patna 400kV D/c (quad) line
- (K) Teesta III – Kishanganj 400kV D/c line (quad)
- (L) LILO of both circuits of Teesta III – Kishanganj 400kV D/c line at Rangpo with Twin HTLS conductor

**Note:**

- (i) Elements at (A) to (J): Commissioned by POWERGRID.
- (ii) Element at (K): Being implemented by TPTL (JV of POWERGRID and Teesta Urja Ltd.). Teesta-III – Rangpo 400kV D/c (one circuit via Dikchu) has been commissioned except Dikchu-Rangpo section. Rangpo to Kishanganj section is expected by Mar 2018 (as informed in 12<sup>th</sup> JCC of Eastern Region held on 27-03-2017).
- (iii) Element (L): LILO of one circuit has been commissioned by POWERGRID.

25.2 The dedicated and above mentioned common transmission system associated with Phase-I generation projects in Sikkim (except Chuzchen which was granted LTA separately) were intimated by CTU vide letter dated 07-10-2015. Therein, the dedicated transmission system of Bhasmey HEP was modified from “LILO of one ckt of Chuzachen – Rangpo 132kV D/c line with Zebra conductor at

Bhasmey along with associated line bays” to “Bhasmey – Rangpo 132kV D/c line along with associated line bays”.

- 25.3 In the 18<sup>th</sup> Standing Committee Meeting of ER held on 13-06-2016, it was decided to delink the LILO of 2<sup>nd</sup> circuit of Teesta-III – Kishanganj 400kV D/c line at Rangpo from the scheme “Transmission System for Transfer of power from generation projects in Sikkim to NR/WR (Part-B)” for Phase-1 IPPs in Sikkim and take it up as a separate part (Part-B1) as “Transmission System for Transfer of power from generation projects in Sikkim to NR/WR (Part-B1)”. From system studies, it has been observed that power from the above mentioned Phase-I IPPs can be evacuated with LILO of one circuit of Teesta-III – Kishanganj line at Rangpo with N-1 security criteria (the original transmission system was planned keeping in view N-1 criteria). The 2<sup>nd</sup> LILO at Rangpo is required for meeting the N-1-1 reliability criteria. From system studies, it has also been observed that common transmission system identified for Phase-1 IPPs is also capable of evacuating power from Tashiding HEP (of Shiga Energy Pvt. Ltd.).
- 25.4 All the elements of the above mentioned Common Transmission System for Phase-I IPPs except Teesta-III – Kishanganj 400kV D/c (Quad) line (part commissioned) has been commissioned. This line (under construction by TPTL) is expected by Mar 2018. With the completion of this line, the LTA of Sikkim Phase-I IPPs and Tashiding HEP may be operationalized. The 2<sup>nd</sup> LILO at Rangpo, which is under award stage, would be commissioned at later stage.
- 25.5 In view of the above, members agreed that the following common transmission system is capable of power evacuation from Phase-I IPPs and Tashiding generation projects in Sikkim:

**Common Transmission System (under scope of ISTS)**

- (a) Establishment of 2x500MVA, 400/220kV GIS sub-station at Kishanganj
  - (b) Establishment of 16x105MVA (single phase), 400/220kV and 3x100MVA, 220/132kV GIS substation at Rangpo
  - (c) Establishment of 220kV GIS switching station at New Melli
  - (d) Teesta-III – Kishanganj 400kV D/c line (quad)
  - (e) Kishanganj – Patna 400kV D/c (quad) line
  - (f) LILO of New Siliguri – New Purnea 400kV D/c line (quad) at Kishanganj
  - (g) LILO of Siliguri – Dalkhola 220kV D/c line at Kishanganj
  - (h) LILO of Teesta-V – New Siliguri 400kV D/c line at Rangpo
  - (i) LILO of one circuit of Teesta-III – Kishanganj 400kV D/c line (quad) at Rangpo (with Twin HTLS)
  - (j) Rangpo – New Melli 220kV D/c line (with Single HTLS)
  - (k) LILO of Rangit – Gangtok 132kV S/c line at Rangpo
  - (l) LILO of Gangtok – Melli 132kV S/c line at Rangpo
- 25.6 Moreover, the dedicated transmission system was finalised as mentioned below:

**Dedicated Transmission System**

---

<b>under scope of generation developer</b>		
(a)	Teesta-VI	Teesta-VI – Rangpo 220kV D/c line with Twin Moose conductor along with associated line bays.
(b)	Jorethang	Jorethang – New Melli 220kV D/c line with Zebra Conductor along with associated line bays.
(c)	Rangit-IV	Rangit-IV – New Melli 220kV D/c line with Zebra Conductor along with associated line bays
(d)	Rongnichu	Rongnichu – Rangpo 220kV D/c line with Zebra conductor along with associated line bays
<b>under scope of generation developer / Govt. of Sikkim</b>		
(e)	Chuzachen	Chuzachen – Rangpo 132kV D/c with Zebra conductor along with associated line bays
(f)	Bhasmey	Bhasmey – Rangpo 132kV D/c line along with associated line bays

- 25.7 Further, CTU requested Govt. of Sikkim representative to clarify regarding ownership of dedicated transmission lines (viz. Chuzachen – Rangpo and Bhasmey – Rangpo 132kV D/c lines) of the Chuzachen and Bhasmey HEPs and the associated line bays at Rangpo. Govt. of Sikkim representative stated that they would inform the same later.
- 25.8 Representative of NLDC expressed that Rangpo – Silliguri line reconductoring with HTLS may be expedited. This will increase the reliability otherwise there could be reliability constraint. Representative of POWERGRID stated that Teesta – Kishanganj line of TPTL is delayed, when this line is commissioned the evacuation constraints of Sikkim HEPs would be resolve.
- 25.9 After discussion, members agreed to the following:
- (a) Modification of the common and dedicated transmission system required for LTOA/LTA of Sikkim Phase-I IPPs and Tashiding HEP to the system mentioned at para 25.5 of above. It was decided to issue modification to already issued LTOA/LTA intimations incorporating the approved transmission system. Upon revision, the applicant/generation developer/transmission licensee/Govt. of Sikkim etc. shall sign the revised annexures of already signed BPTA.
  - (b) Modification of dedicated transmission system of Bhasmey HEP to Bhasmey – Rangpo 132kV D/c line along with associated line bays at both ends: **ownership of the dedicated line needs to be confirmed by Govt. of Sikkim**
  - (c) With completion of the common transmission system mentioned at para 25.5, LTOA/LTA of Sikkim Phase-I IPPs and Tashiding HEP would be operationalized and the applicants / generation developers / long term

beneficiaries, as the case may be, shall be liable for payment of applicable transmission charges as per their contracted capacities. In case of default by beneficiaries, LTA customer shall be liable for payment of transmission charges. The 2<sup>nd</sup> LILO at Rangpo, which is under award stage, would be commissioned at later stage.

- (d) Reconductoring of Rangpo – Silliguri line with HTLS may be expedited. This will increase the reliability of evacuation of power beyond Rangpo.

**26. Connectivity granted to Vedanta Ltd. (erstwhile Sterlite Energy Ltd.)**

26.1 Representative of CTU informed that Vedanta Ltd. (4x600MW) was granted LTA of 400MW in Phase-I along with other IPPs in Odisha and LTA of 1000MW along with other IPPs in Odisha in Phase-2. For connectivity, Vedanta was to construct two 400kV D/c lines (one for 400MW LTA and another for 1000MW LTA) from the generation switchyard to Sundargarh (Jharsuguda) S/s of POWERGRID. Subsequently, Vedanta Ltd. has relinquished its entire LTA quantum of 1400MW(Phase-I: 400MW & Phase-II: 1000MW). The first dedicated line is still under construction, whereas the second dedicated line has not been taken up for implementation. Connection agreements have been signed between CTU (POWERGRID) and Vedanta Ltd. for both the dedicated transmission lines.

26.2 Vedanta had connected Unit-1, 3 & 4 of the generation project to ISTS system and Unit-2 to Odisha grid. In the 125<sup>th</sup> OCC meeting of ERPC held on 20-09-2016 under the agenda item no. B.7 – “Persistent under generation and inappropriate operational methodologies vis-à-vis grid requirements in operation of Vedanta, Jharsuguda”, it has emerged that Vedanta has got converted the status of ISTS connected units from IPP to CPP.

26.3 The matter related to Vedanta was subsequently discussed in a meeting at ERPC on 14-10-2016, wherein following was decided:

- (a) *Control area jurisdiction of Vedanta will be shifted from ERLDC to SLDC, Odisha.*
- (b) *CPP units (unit #1, 3 &4) and IPP unit (#2) of Vedanta Ltd along with SEZ (smelter) load shall be kept at 400 kV bus of Vedanta Ltd Switchyard without bus splitting and shall be connected to STU network through 400 kV Vedanta Ltd-Meramundali D/C line.*

*There will be no need to operate the 400kV buses of Vedanta in split bus mode and they should be coupled by completing all the dias.*

- (c) *One unit shall be kept as standby till the completion of 400 kV Sterlite-Jharsuguda D/C line.*
- (d) *Vedanta Ltd shall be a State embedded entity for all purposes and requisite STU connection would be obtained by Vedanta Ltd i.r.o above.*
- (e) *The CTU connectivity of Vedanta may be kept in abeyance. The same may be closed/withdrawn from the date of getting the STU connectivity.*
- (f) *On change of control area jurisdiction the NOC granted by ERLDC to Vedanta Ltd shall stand revoked.*

- (g) *After changeover of control area jurisdiction, the LILO point of 400 kV Rourkela-Raigarh at Vedanta will be interface point of Odisha STU till 30th November, 2016.*
- (h) *Subsequently, after the completion of 400kV Sterlite-Jharsuguda D/C line the interface point of Odisha STU will be shifted to Jharsugada.*
- (i) *With the change of control area jurisdiction the status of 400kV Sterlite-Jharsuguda D/C line will no more be a dedicated line. So, Vedanta agreed to hand over the line to OPTCL which can be treated as an ISTS tie of OPTCL.*
- (j) *Vedanta has to strictly adhere to the schedule for completion of 400kV Sterlite-Jharsuguda D/C line (i.e. 30th November, 2016) as per the decision of 33rd TCC/ERPC and decided in the meetings held in CEA on 16.9.16. In case 400kV Vedanta-Jharsuguda D/C line is not commissioned by that date, the LILO connection to Vedanta shall be withdrawn.*

26.4 For above mentioned deliberations of OCC and ERPC meetings, following were emerged:

- a. ISTS connected units (Unit-1, 3 & 4) of Vedanta has been converted from IPP to CPP and the same shall now be kept connected with STU connected unit (Unit-2). With this all four generating units would be connected to STU and ISTS system through Vedanta – Meramundali 400kV D/c line and Vedanta – Sundargarh (Jharsuguda) 400kV D/c respectively.
- b. Upon completion of Vedanta – Sundargarh (Jharsuguda) line, Vedanta has to hand over the line to OPTCL. In such case, the status of the line would change from dedicated transmission line to STU line. With this Vedanta would be embedded entity of Odisha.

26.5 OPTCL was requested to confirm about the transfer of the Vedanta generation switchyard – Sundargarh (Jharsuguda) 400kV D/c line to OPTCL from Vedanta Ltd. CTU stated that the connection agreement of the first dedicated transmission line shall become null and void upon transfer of the dedicated line by Vedanta Ltd. to OPTCL. He further added that with relinquishment of LTA of 1000MW (Phase-II) by Vedanta Limited, the 2<sup>nd</sup> dedicated line viz. Vedanta generation switchyard – Sundargarh (Jharsuguda) 400kV 2<sup>nd</sup> D/c line is not required.

26.6 In view of above deliberations, members decided that the 2<sup>nd</sup> dedicated line viz. Vedanta generation switchyard – Sundargarh (Jharsuguda) 400kV 2<sup>nd</sup> D/c line is not required and not to be implemented.

**27. Dropping of Banka (PG) – Deoghar 132kV D/c line which was proposed in 16<sup>th</sup> SCM-ER meeting**

27.1 Director (PSPA-2), CEA, CEA informed that, in the 16<sup>th</sup> SCM-ER meeting, ERPC had informed that the 132kV Deoghar S/S (JSEB) is being fed through 132kV line(s) from DVC source (Maithon-Jamtara-Deoghar 132kV S/C) or from NTPC source (Lalmatia). There is also a feed from BSPTCL source through Sultanganj



- Deoghar 132kV S/C line, which is normally kept open due to overloading in Kahalgaon-Sabour- Sultanganj 132kV section of BSPTCL system. The Deoghar & Jamtara sub-stations feed important railway loads of 10MW each to Shankarpur TSS & Jamtara TSS and loading on Maithon – Jamtara – Deoghar 132kV S/C line sometimes exceeds 75MW. The reliability of supply to railway loads is being affected. In view of above, it was agreed to provide an additional supply to Deoghar S/S (JSEB) from 400/132kV Banka S/S (PG) by creating a 132kV Banka- Deoghar D/C lines (about 40 kms).
- 27.2 JUSNL vide their letter dated 30.07.2015 addressed to POWERGRID informed that termination of above line at Deoghar is not possible due to space constraint. Further, JUSNL informed that after commissioning of 132kV Jasidih – Deoghar line (about 5km), Deoghar S/s will be able to receive 250MVA of power through Jasidih S/s and Dumka S/s, whereas the transformation capacity at Deoghar is only 150MVA. The matter was discussed in 18th SCMPSP(ER) meeting and it was decided to review the possible interconnections at Deoghar in a separate meeting at CEA with Railways & other stakeholders.
- 27.3 In regard to above, a meeting was held on 13.06.2017 (Minutes is at **Annexure-27.1**), in which representative of CTU informed that POWERGRID has closed the ERSS-XVI project involving construction of Banka (PG) - Deoghar 132kV D/C line and the same was informed to CEA vide letter dated 27-10-2016.
- 27.4 In the meeting held on 13-06-2017, representative of BSPTCL stated that BSPTCL can supply power with exiting system to Deoghar (Jharkhand) through 132kV Sultanganj - Deoghar S/C line during off-peak hours only, as the bus bars capacity at Sultanganj is inadequate. However, supply during peak hours would be possible only after strengthening of bus bar at Sultanganj, which is likely to be completed in next six months.
- 27.5 Director (PSPA-2), CEA, CEA informed that the proposed Deoghar-Jasidih 132kV D/C line (by JUSNL) and strengthening of 132kV bus at Sultanganj (by BSPTCL) are likely to enhance the reliability of power supply to the Railways TSS at Deoghar. In view of above, it was decided to drop the proposal of construction of Banka (PG) - Deoghar 132kV D/C line.
- 27.6 Members agreed for dropping of Banka (PG) – Deoghar 132kV D/c line (i.e. ERSS-XVI scheme).
- 28. Upgradation of 132kV bus arrangement at 400/220/132kV Malda S/s of POWERGRID**
- 28.1 Representative of POWERGRID stated that Single Main & Transfer (SMT) scheme is functional at 132kV level and Double Main & Transfer (DMT) scheme at 400kV & 220kV levels at Malda S/s. The transformation capacity at Malda S/S at 220/132kV is being upgraded from 370MVA (2x160MVA+1x50MVA) to 480MVA (3x160MVA) under ERSS-XX. The Malda 132kV main bus is of Single Moose Conductor. Due to increased loading at 132kV level, problems in the main bus are being encountered more often. Malda (POWERGRID) – Malda

(WBSETCL) 132kV D/c line has been reconducted from Panther (ACSR) to Casablanca (ACCC) by WBSETCL, thereby increasing current carrying capacity from 366A to 1120A per circuit . In the 18<sup>th</sup> ER-SCM, it was agreed that WBSETCL may terminate Malda (WBSETCL) – Samsi 132kV S/c line at Malda (POWERGRID) as an interim measure before summer of 2017 to relieve the loading on Malda (POWERGRID) – Malda (WBSETCL) 132kV D/c line.

- 28.2 Further, he stated that Malda is an important substation in northern part of West Bengal which remains critically loaded at 132kV level. With SMT scheme, complete shutdown of 132kV bus is required for maintenance works in the main bus. Thus, keeping in view the importance of Malda S/s and in order to improve reliability at 132kV level, bus arrangement including switchgear are proposed to be upgraded to Double Main (DM) scheme by POWERGRID, in a similar manner as being implemented at Siliguri and Birpara 132kV level under other schemes. Due to space constraints, the upgradation work needs to be carried out through GIS bays.
- 28.3 Representative of CEA stated that Gazol 220/132kV Sub-station(2x160MVA) with the LILO of Malda-Dalkhola 220kV D/C line of POWERGRID was approved in 2nd-2013 meeting of the Standing Committee on Power System Planning of Eastern Region (15th SCMPSP-ER) held on 27.08.2013. Proposed and existing power map of Malda district is at **Annexure- 28.1**. Therefore reliability of power supply increases in Malda district with the commissioning of Gazol sub-station with associated lines.
- 28.4 Further, he stated that bus maintenance is not required frequently and requires few hours of shutdown, which could be planned during off-peak hours and during that period the power could be supplied to Malda district through Gazol sub station. SMT scheme is having advantage of carrying out breaker maintenance without shutdown/outage of corresponding load/ICT, which is not possible in the proposed DM (Double Main) Bus scheme.
- 28.5 Member (Power System), CEA queried WBSETCL regarding the above proposal.
- 28.6 Representative of WBSETCL replied that 220/132/33kV Gazol substation would be commissioned by December, 2018. After commissioning of Gazol substation, planned 132kV bus shut down/ maintenance could be taken at Malda (POWERGRID) substation. Therefore, upgradation of 132kV bus arrangement at Malda (POWERGRID) is not required.
- 28.7 In view of the above, members dropped the proposal for upgradation of 132kV bus arrangement at 400/220/132kV Malda S/s of POWERGRID

**29. Modification under 13<sup>th</sup> Plan scheme: Agenda by BSPTCL**

- 29.1 Director, BSPTCL stated that, Sitamarhi, Chandauti and Saharsa (New) substations were approved under ISTS in the 18<sup>th</sup> ER-SCM held on 13-06-2016 to meet the future demand of Bihar by 2021-22. The scheme is being

implemented through TBCB under ERSS-21 (under bidding stage). Therein scope of Sitamarhi (New) & Saharsa (New) S/s inter alia includes following:

**Sitamarhi (New) 400/220/132kV S/s: (400/220kV, 2x500MVA + 220/132KV, 2x200MVA)**

- (a) Darbhanga – Sitamarhi(New) 400kV D/c (Triple Snowbird)
- (b) Sitamarhi (New) – Motihari 400kV D/c (Triple Snowbird)
- (c) Sitamarhi (New) – Motipur 220kV D/c
- (d) Sitamarhi (New) – Sitamarhi 132kV D/c (Single Moose)
- (e) Sitamarhi (New) – Pupri 132kV D/c

**Saharsa (New) 400/220/132kV S/s: (400/220kV 2x500MVA + 220/132kV 2x200MVA)**

- (a) LILO of Kishanganj – Patna 400kV D/c (Quad) at Saharsa (New)
- (b) Saharsa (New) – Begusarai 220kV D/c
- (c) Saharsa (New) – Khagaria (New) 220kV D/c
- (d) Saharsa (New) – Saharsa 132kV D/c (Single Moose)

29.2 However, due to space constraints for additional line bays and unavailability of corridor some modifications are required for plan period 2017-2022. A joint load flow study has been carried out by BSPTCL with POWERGRID and following modification is proposed in the intra-state portion (under scope of BSPTCL):

Sl.No.	400/200/132 kV New Sub-station	Original Scope	Proposed Modification	Justification
1	Sitamarhi (New)	Sitamarhi (New) – Sitamarhi 132kV D/c (Single moose)	Sitamarhi (New) – Runnisaipur 132kV D/c	Space is not available for new line bay as well as corridor is not available for line termination at 132kV Sitamarhi (old) GSS.
		Sitamarhi (New) – Pupri 132kV D/c	LILO of Benipatti - Pupri 132 kV S/c at Sitamarhi (New)	Severe ROWs and Densely populated area around Grid Substation, Pupri
2	New Line	Vaishali – Hazipur 132kV D/c	Vaishali – Chapra (New) (Amnour) 132kV D/c	No corridor available at entry point of 220/132kV GSS Hajipur and severe ROW problems due to dense population.
3	Saharsa (New)	Saharsa (New) – Saharsa 132kV D/c (Single Moose)	LILO of Saharsa (BSPTCL) – Banmankhi 132kV S/c line at Saharsa (New) 400/220/132 kV	As reported by field office, Space is not available for new line bay at 132/33 kV Saharsa (old) GSS of

Sl.No.	400/200/132 kV New Sub-station	Original Scope	Proposed Modification	Justification
			LILO of Saharsa (BSPTCL) – Udakishanganj 132kV S/c line at Saharsa(New) 400/220/132 kV	BSPTCL as well as corridor is not available
		Stringing of 2 <sup>nd</sup> circuit of Saharsa (Old) – Sonebarsa (formed after LILO of Madhupura – Sonebarsa 132kV S/c on D/c line at Saharsa (Old)) 132kV S/c on D/c line section	LILO of one of the circuit of Madhupura – Sonebarsa 132kV D/c line at Saharsa(New) 400/220/132 kV  [one circuit is already being LILOed at Saharsa (BSPTCL), the other circuit is to be LILOed at Saharsa (New) 400/220/132 kV]	
4	Stringing of 2 <sup>nd</sup> Circuit	Stringing of 2 <sup>nd</sup> circuit of Muzaffarpur – SKMCH 132kV S/c on D/c	Reconductoring of 132kV S/c Muzaffarpur – SKMCH lines with HTLS of 240MVA (1050A ampacity)	The existing 132kV Muzaffarpur – SKMCH Tr. Line is single circuit single strung.

### 29.3 Scope to be deleted

- Sitamarhi (New) – Sitamarhi 132kV D/c (Single Moose).
- Sitamarhi(New) – Pupri 132kV D/c.
- Vaishali – Hazipur 132kV D/c.
- Stringing of 2<sup>nd</sup> circuit of Muzaffarpur – SKMCH 132kV S/c on D/c.
- Saharsa (New) – Saharsa 132kV D/c (Single Moose).
- Stringing of 2<sup>nd</sup> circuit of Saharsa (Old) – Sonebarsa (formed after LILO of Madhupura – Sonebarsa 132kV S/c on D/c line at Saharsa (Old)) 132kV S/c on D/c line section.
- Nos. of 132 kV Line bays at Saharsa (New) S/s: 2 nos.  
[2 no. for Saharsa (New) – Saharsa 132kV D/c (Single Moose) line]

### 29.4 Scope to be Added

- 400/220/132 kV Sitamarhi (New) – Runnisaidpur 132kV D/c.
- LILO of Benipatti - Pupri 132 kV S/c at Sitamarhi (New) 400/220/132 kV.
- Vaishali – Chapra (New) (Amnour) 132 kV D/c.
- Reconductoring of 132kV S/c Muzaffarpur – SKMCH lines with HTLS of 240MVA (1050A ampacity).
- LILO of 132/33 kV Saharsa (Old) BSPTCL – Banmankhi 132kV S/c line at Saharsa (New) 400/220/132 kV.

- (f) LILO of 132/33 kV Saharsa (Old) BSPTCL – Udakishanganj 132kV S/c line at Saharsa(New) 400/220/132 kV.
- (g) LILO of one of the circuit of Madhupura – Sonebarsa 132kV D/c line at Saharsa(New) 400/220/132 kV. [one circuit is already being LILOed at Saharsa (BSPTCL), the other circuit is to be LILOed at Saharsa (New) 400/220/132 kV]
- (h) Nos. of 132 kV Line bays at Saharsa (New) S/s: 6 nos.  
*[2 no. for LILO of each of the following 132kV lines at Saharsa (New):*
  - i. LILO of Saharsa (BSPTCL) – Banmankhi.*
  - ii. LILO of Saharsa (BSPTCL) – Udakishanganj.*
  - iii. LILO of one circuit of Madhupura – Sonebarsa.]*

29.5 Further, he informed that after the above modification 6 nos. 132 KV bays are required at Saharsa (New) Substation (400/220/132 KV, 2x500+2x200 MVA) whereas 2 nos. of 132 KV bays were approved at the Saharsa (New) Substation. He requested RECTPCL (Bid Process Coordinator for ERSS-XXI) to include the 6 nos. of 132 KV bays instead of 2 nos. of 132 KV bays at Saharsa(new) and accordingly scope of work could be modified.

29.6 Director, CEA stated that ERSS-XXI is in the advanced stage of tendering by RECTPCL. It would be difficult to change the scope of ERSS-XXI at this stage. It would be better if BSPTCL would construct these additional 132kV line bays at Saharsa on their own, these additional bays could be constructed in matching time frame of their connecting lines.

29.7 Members agreed for the above changes in the intra-state system of BSPTCL, Bihar. It was also decided that the additional 132kV line bays at Saharsa (New) ISTS S/s may be constructed by BSPTCL at its own cost.

**30. To provide one additional 400/220kV, 500MVA ICT at Patna (POWERGRID)**

30.1 Director, BSPTCL informed that the power demand of Patna and surrounding areas is increasing at faster rate. The load requirement of central and eastern Patna is substantial due to presence of various commercial, institutional & educational establishments, and dense urban population. The load demand is largely fed by Patna (POWERGRID) S/s with the transformation capacity of 1X500 MVA + 1X315 MVA (to be replaced with 500MVA). The connected load to the above GSS is as follows:-

- (a) 220/132kV GSS Gaurichak– 1X160 + 2X150 MVA= 460 MVA
- (b) 220/132/33kV GSS Khagaul – 4X100 MVA = 400 MVA
- (c) 220/132/33kV GSS Fatuha – 5X100 MVA = 500 MVA
- (d) 220/132/33kV Bihta (New) – 2X160 MVA = 320 MVA (Likely to be commissioned at the end of 2017).

30.2 To cater the growing demand of state capital, three new 400/220kV intra-state substations (Bihta, Gaihat and Fathua) with 2x500MVA transformation capacity were planned around Patna area in 2010-11 for completion in 12th plan.

However, due to non-availability of land at these locations the substations could not be taken up for implementation. Accordingly, revised joint studies were carried out with CEA, CTU and BSPTCL in 2016 considering new substations at Naubatpur, Bakhtiyarpur and Jakkanpur in place of Bihta, Gaighat and Fatuha respectively. Due to the delay in implementation of three new intra-state substations, there is an urgent requirement of a new ICT at Patna (POWERGRID) S/s.

- 30.3 Further, he stated that loading of Patna (POWERGRID) S/s is very critical. The average load at present on ICTs is about 550MW and the peak load is about 650MW, which may increase to 820MW in the coming year so it is not fulfilling the N-1 reliability criteria. On 03-07-2017, one 500MVA ICT tripped on fault, as a result another 315MVA ICT also tripped on overload and the major part of the state capital faced total blackout on that day.
- 30.4 Accordingly, he requested for installation of an additional 400/220kV, 500MVA ICT at Patna (POWERGRID) S/s for meeting N-1 reliability and in turn ensuring uninterrupted power to state capital in the event of outage of one of the ICTs.
- 30.5 Representative of CTU stated that Patna 400/220kV sub-station earlier had 2x315MVA, 400/220kV ICTs. One 315MVA ICT has already been replaced with 500MVA ICT. The 2<sup>nd</sup> 315MVA ICT is to be replaced with 2<sup>nd</sup> 500 MVA ICT which has already been awarded and is expected in next few months. Now, 3<sup>rd</sup> 500MVA ICT is proposed to be installed, however, there is a space constraint for this 3<sup>rd</sup> ICT. The space for the 3<sup>rd</sup> ICT could be created by shifting one of the existing 420kV, 125MVA<sub>r</sub> bus reactor and installing it in one of the circuits of Patna – Barh lines as a switchable line reactor at Patna end to be utilised as bus reactor. In case of line outage, the reactor would be connected to bus as bus reactor. In regard to requirement of NGR, representative of CTU replied that NGR is not required as the Patna – Barh line is a short line.
- 30.6 Members approved the following:
- (a) Shifting of one of the existing 420kV, 125MVA<sub>r</sub> bus reactors at Patna and installation of the same in one of the circuit of Barh-Patna lines as switchable line reactor, which can be used as bus reactor in case of outage of line.
  - (b) Space created by shifting of bus reactor would be utilised for placement of 500 MVA ICT.
  - (c) Additional 400/220kV, 500MVA ICT (3<sup>rd</sup>) along with associated bays at Patna.

**31. Bus and Bay strengthening at Purnea (POWERGRID) S/s**

- 31.1 Representative of BSPTCL has informed that reconductoring of 132kV Purnea (POWERGRID) – Purnea (BSPTCL) T/c transmission line from Panther to HTLS conductor has already been completed and line is charged. Now each circuit capacity is 1000 Amp i.e. about 200MW. It has been planned to test the line for

its loading, which requires compatibility of 132kV main bus bar, bay equipment etc. at both Purnea (POWERGRID) and Purnea (BSPTCL) GSS ends.

- 31.2 BSPTCL has awarded the contract for R&M of Purnea (BSPTCL) GSS, which includes the upgradation of bus bar & bay equipment to handle enhanced capacity of line due to reconductoring using HTLS conductor. These works are expected to be completed shortly. For drawing optimum power from Purnea (POWERGRID) end, bus & bay equipment must be capable to sustain the load. The matter was discussed in 134th OCC meeting held on 11.07.2017 at ERPC, Kolkata also.
- 31.3 Director (PSPA-2) informed that POWERGRID vide its letter dated 10-08-2017 has clarified that, in order to improve reliability of 132kV system at Purnea (POWERGRID) 220/132kV S/s, the 132kV bus scheme along with switchgear is already being upgraded under ERSS-XII scheme from Single Main & Transfer (AIS) to Double Main (GIS) with 132kV bay equipment and bus bar capable of handling 1250A and 2000A respectively. The work would be completed by 30-09-2017.
- 31.4 Members noted the status of upgradation of bus bar & bay equipment at Purnea (POWERGRID) & Purnea (BSPTCL) to handle enhanced capacity of line due to reconductoring using HTLS conductor.

**32. Limiting fault current level at 400kV bus at Farakka TPS (NTPC)**

- 32.1 Director (PSPA-2), CEA informed that CTU had intimated that three phase fault level at Farakka TPS (NTPC) at 400kV bus is found to be exceeding the designed short time current rating of equipment of 40kA. In this regard, a meeting was held on 13.06.2017 at CEA, New Delhi.
- 32.2 In the meeting, representative of CTU stated as follows:
- (a) The three phase fault level at Farakka TPS (NTPC) at 400kV bus is found to be exceeding the designed short time current rating of equipment (i.e. 40kA). Presently, the fault level is about 46kA. Accordingly, system studies have been performed to propose measures to limit the fault current level by adopting various technical options like - bus splitting, switching arrangement, bypassing of lines, which were terminating at the specific substation or installation of series reactor or installation of fault current limiter etc. Moreover, the fault level of Farakka generation switchyard in 2021-22 time-frame is expected to be about 57.6kA. The expected power flow and fault current at Farakka bus is shown below:

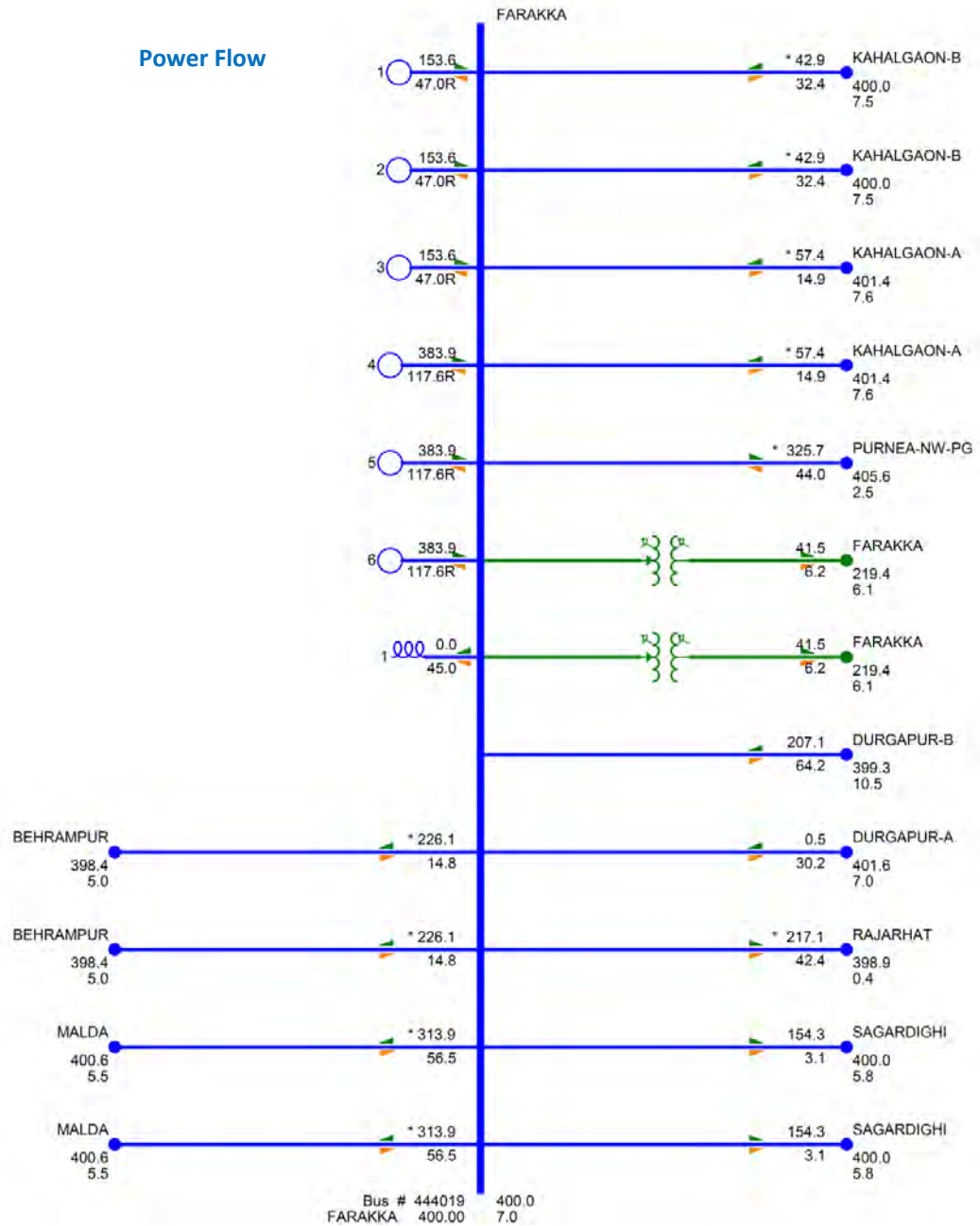



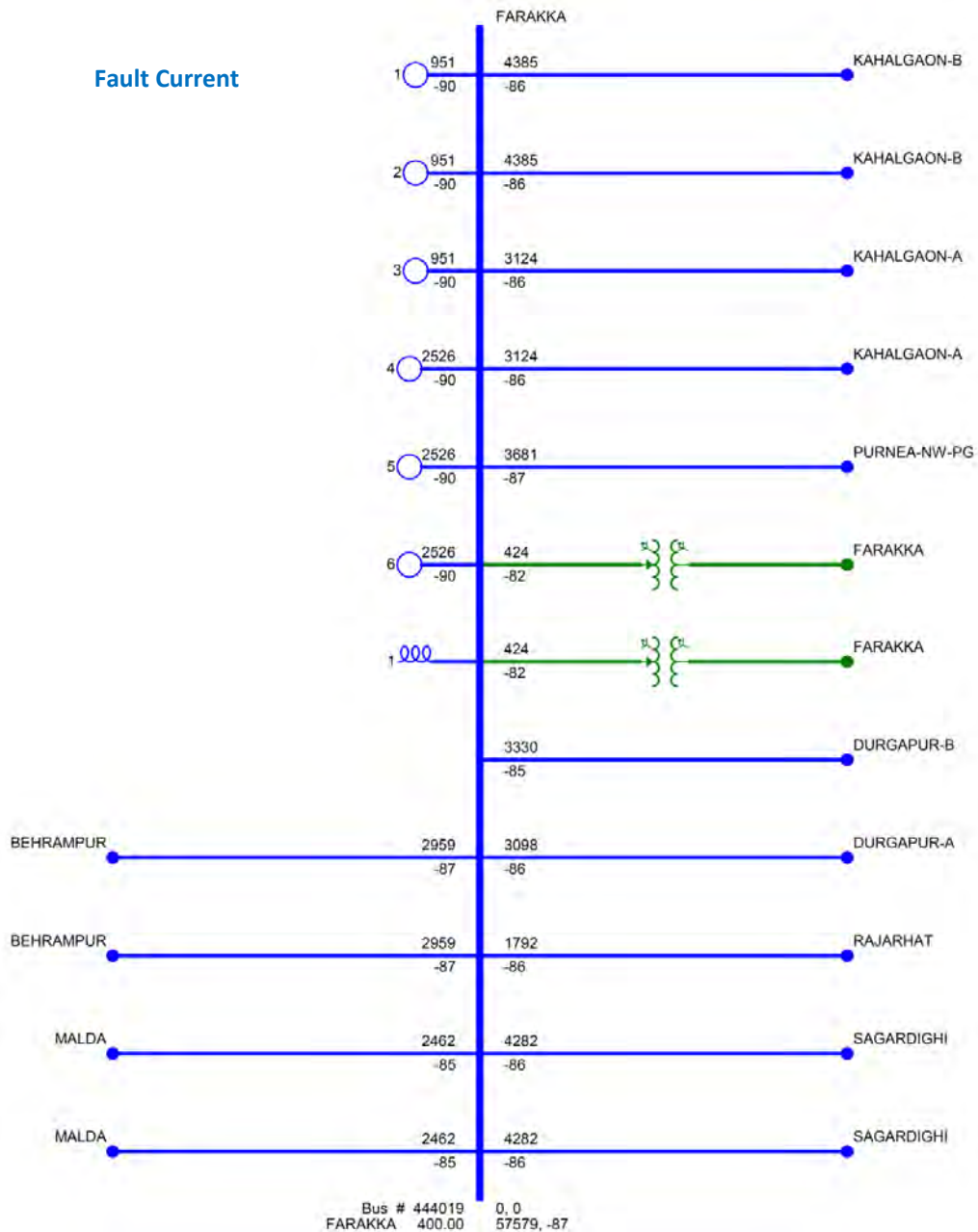

- (b) To limit the fault current level at Farakka, it is proposed to bypass Durgapur – Farakka (150km) 400kV D/c and Farakka – Kahalgaon (95km) 400kV 1st D/c (ckt-1 & 2) lines outside the switchyard so as to form Durgapur – Kahalgaon 400kV D/c line. With this arrangement fault level at Farakka reduces to 47kA from 57.5kA in the timeframe of 2021-22.
- (c) In order to further reduce the fault level, it was proposed to sectionalise the Farakka 400kV bus and install a 12 ohm series reactor between the two bus sections as per arrangement shown below. With this proposed rearrangement the fault level of the two bus sections viz. Farakka-A and Farakka-B comes down to 33.5kA and 37.5kA respectively. Study results showing feeder wise power flow and fault current contribution (with and without series reactor) is shown below:

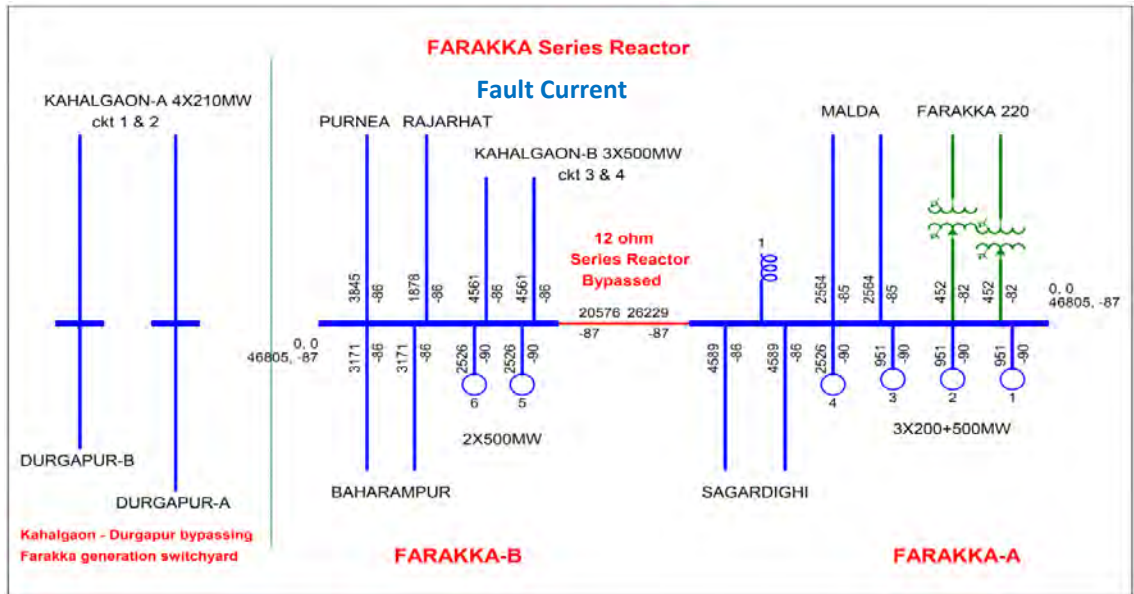
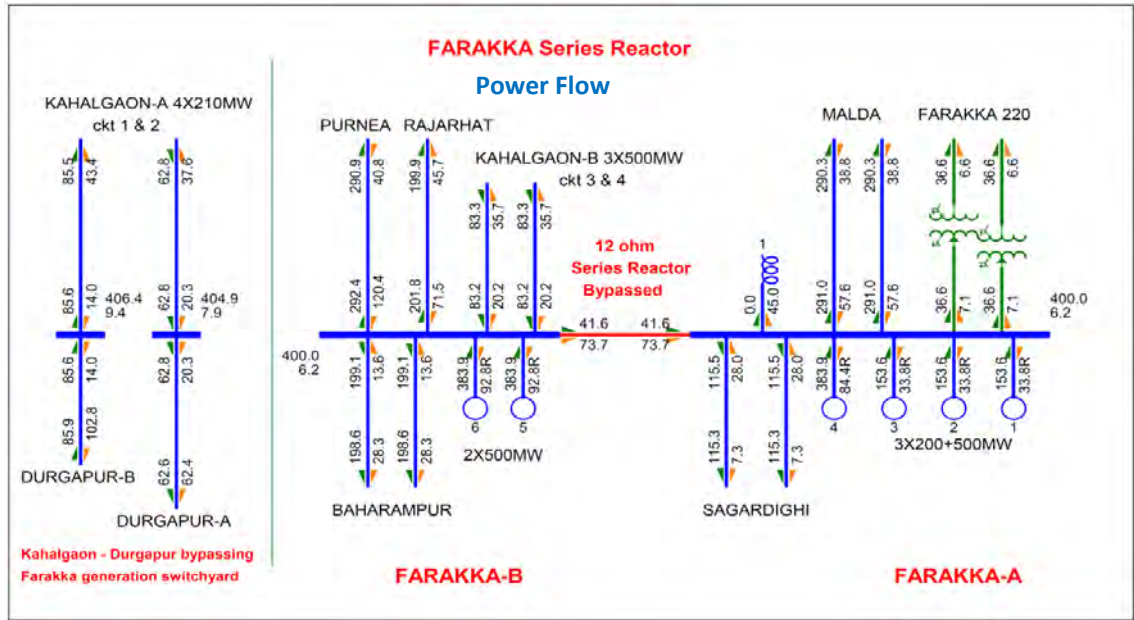

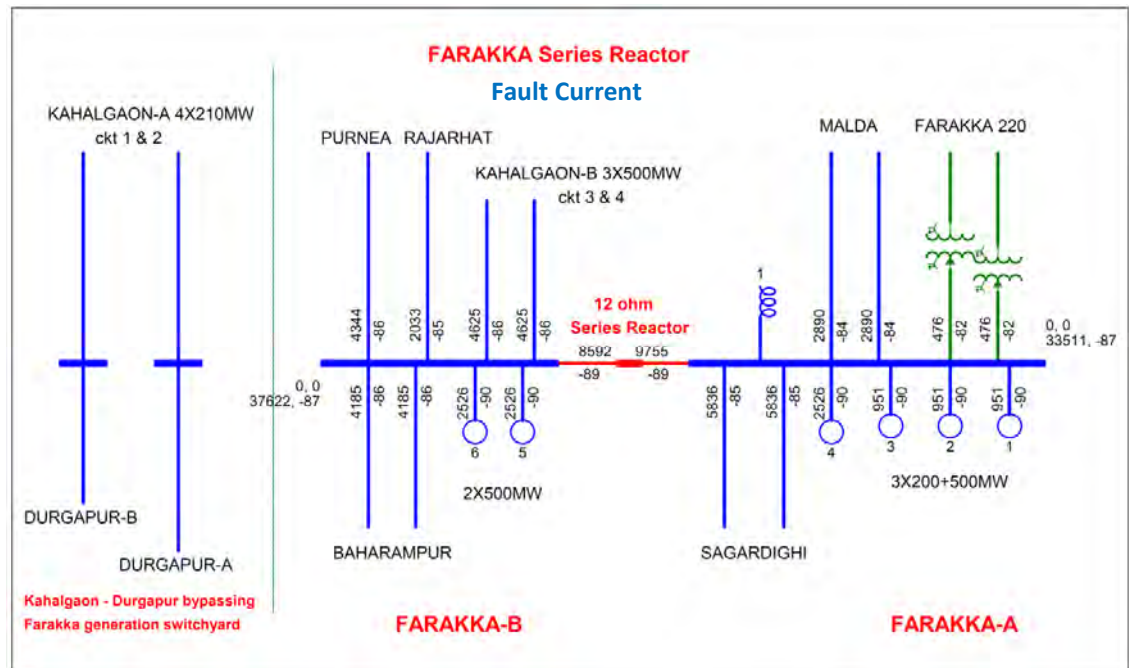
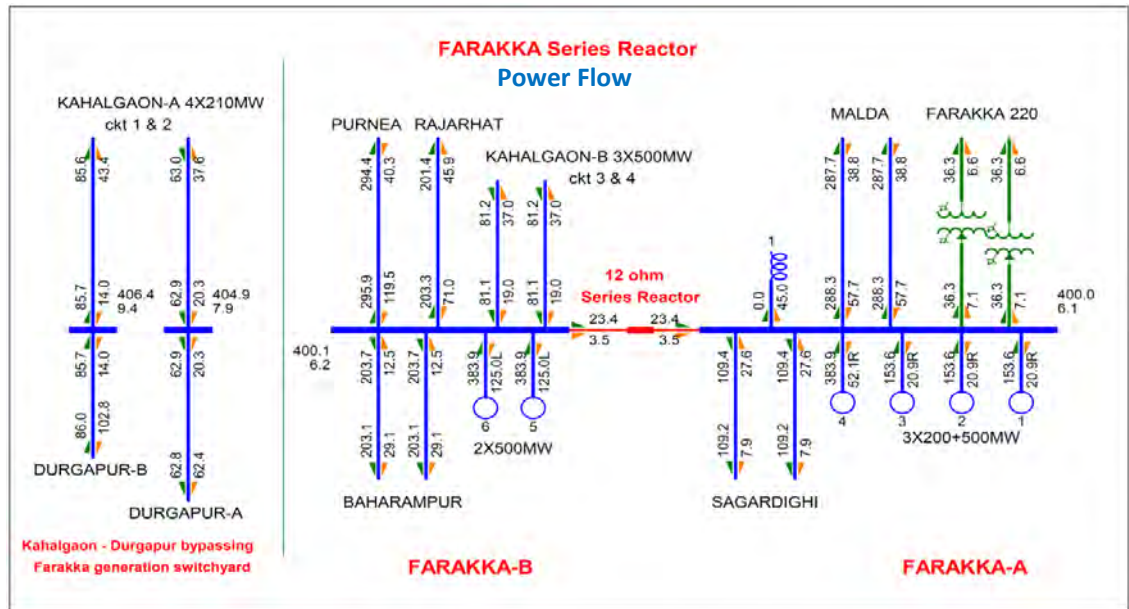

32.3 From above study results, it may be observed that power flow on the transmission lines connected at either sections of Farakka bus is within acceptable limits.

32.4 In the meeting, representative of NTPC informed that the Auxiliary power supply system for the entire Farakka generating station is derived from a common 33kV system which is fed from the generation voltage level through Two number tie transformers connected in Section-A and One number tie transformer connected in Section-B. Further, presently there is no provision of segregation of Auxiliary power supply system (at 33kV level) between the units connected on Bus section-A (Units # 1,2,3 & 4) and Bus section-B (Units # 5 & 6) respectively. As

such in case of voltage and angle difference between the two 400 kV Bus sections, huge amount of unintended power flow may occur through the station 33kV supply system risking the reliability and safety of the system and may lead to interruptions in the station auxiliary power supply.

- 32.5 In the meeting held on 13-06-2017, following were agreed:
- (i) Keeping in view the present fault level of 46kA at Farakka substation, it was opined that initially only Durgapur – Farakka (150km) 400kV D/c and Farakka – Kahalgaon (95km) 400kV 1<sup>st</sup> D/c (ckt-1 & 2) lines may be bypassed outside the switchyard so as to form Durgapur – Kahalgaon 400kV D/c line by POWERGRID. With above modified arrangement the fault level at Farakka in present time-frame reduces to about 35kA (provided Kahalgaon 400kV bus is split by NTPC as planned, otherwise the fault level at Farakka substation would be about 36.5kA).
  - (ii) CTU would study for the maximum voltage and angle difference between the 400kV bus sections between of Farakka-A and Farakka-B and the report would be shared with NTPC and CEA.
  - (iii) NTPC would study the proposal of series reactor in detail and submit their comments/observations, if any.
  - (iv) Based on comments/study results mentioned at (ii) & (iii) above, the proposal of bus splitting and installation and implementation of series reactor at Farakka Generating station would be reviewed in a special meeting at CEA along with NTPC and POWERGRID.
- 32.6 ERPC informed that Farraka STPS (Unit 1 to 5) has been identified under projects considered for retirement as per new environmental norms (thermal station units without space for FGD installation and attaining age of 25 years on 01/01/2022)
- 32.7 Director (PSPA-2), CEA queried regarding the status of Kahalgaon bus split. Representative of NTPC informed that Kahalgaon bus split would be commissioned by 2018. In view of increasing fault level, NTPC was requested to expedite implementation of bus splitting at 400kV level at Kahalgaon switchyard.
- 32.8 Chief Engineer (PSPA-II), CEA expressed that 4 number 400kV line bays would be available after the above bypassing arrangement. Therefore, there should be some plan to utilize these bays. Representative of NTPC stated that the cost of these bays has already been capitalized.
- 32.9 Representative of NLDC expressed that line reactor might be required for newly formed Durgapur – Kahalgaon D/c line. Representative of CTU informed that the length of the line would be around 240km and it is a twin moose conductor line, hence as per the study, line reactor is not required.
- 32.10 In view of the above, members agreed that Durgapur – Farakka (150km) 400kV D/c and Farakka – Kahalgaon (95km) 400kV 1<sup>st</sup> D/c (ckt-1 & 2) lines may be

bypassed outside the Farakka switchyard so as to form Durgapur – Kahalgaon 400kV D/c line as ISTS so as to limit fault level at Farakka generation switchyard.

**33. Commissioning of Rajarhat S/s and terminating lines proposed under ERSS-V scheme**

- 33.1 Representative of POWERGRID has informed that Eastern Region Strengthening Scheme-V (ERSS-V) which inter-alia includes Rajarhat 400/220kV, 2x500MVA S/s in West Bengal along with LILO of Jeerat - Subhasgram 400kV S/c line at Rajarhat and Rajarhat - New Purnea 400kV D/c (Triple Snowbird) line (one circuit via Gokarna and other via Farakka) is being implemented by POWERGRID. Almost 99% works at Rajarhat S/s has been completed, however, works at / around Rajarhat had to be stopped in Jan 2017 due to local unrest. POWERGRID was advised by the West Bengal administration to stop all works and withdraw all working personnel including security guards. After intense efforts by POWERGRID and with cooperation of state administration, security personnel have been deployed at site, however, construction work could not be started because of continued local protest. Now, during discussion with Govt. of West Bengal, it emerged that efforts for re-commencement of construction activities can be made only if general public is assured that no more transmission lines would be constructed at and around Rajarhat.
- 33.2 Further, he stated that LILO of Jeerat - Subhasgram 2nd 400kV line is proposed at Rajarhat under ERSS-XVIII, which is being implemented through TBCB route by M/S POWERGRID Medinipur Jeerat Transmission Ltd. He stated that, it would be difficult to implement this LILO as assurance for no more transmission lines to be constructed at and around Rajarhat needs to be given to local public at Rajarhat to avoid the law and order problem. Therefore the LILO needs to be dropped.
- 33.3 In regard to requirement of LILO in the existing situation at Rajarhat, representative of WBSETCL replied that in present scenario they are agreeing to drop the LILO at Rajarhat under ERSS-XVIII scheme.
- 33.4 Member (Power System), CEA stated that POWERGRID may take appropriate steps to remove the LILO from the scope of ERSS-XVIII as this scheme is being implemented by POWERGRID under TBCB. He also stated that no further lines at Rajarhat would be planned.
- 33.5 Member (Power System), CEA enquired that whether individual element cost could be found out in ERSS-XVIII.
- 33.6 Representative of the POWERGRID replied that individual cost of the elements in ERSS-XVIII is available as percentage of total cost of the scheme. The cost of the LILO would be around 0.28% of total cost.
- 33.7 In view of the above discussions, it was agreed in principal that no further works shall be carried out at Rajarhat S/s apart from the works which are under implementation as part of ERSS-V Scheme. Accordingly, LILO of Jeerat-

Subhasgram 2<sup>nd</sup> 400kV line at Rajarhat S/s under ERSS-XVIII needs to be deleted from the scope of the scheme. It was also decided that final decision with regard to deletion of scope of LILO and associated bay extension works at Rajarhat S/s would be taken up in a separate meeting by CEA with all LTTCs of ERSS-XVIII project.

**34. Evacuation system for Talcher-III (2x660MW) project of NTPC**

34.1 Director (PSPA-2), CEA stated that NTPC vide letter dated 30-01-2017 has indicated that they propose to establish a 2x660MW generating plant within the existing Talcher Thermal Power Station Complex in Odisha. Accordingly, they have requested for finalisation of evacuation voltage level and evacuation system for the Talcher-III generation project. Accordingly, a meeting regarding evacuation system of Talcher-III project of NTPC and other issues of transmission system of Odisha was held on 18.08.2017 at CEA. In the meeting following were discussed:

34.2 In the meeting following were discussed:

- (i) 50% power of the Talcher-III generation project has been allocated to Odisha, 35% to various ER beneficiaries (Bihar, West Bengal, Jharkhand and Sikkim) and 15% is unallocated.

Beneficiary	Quantum	Percentage
Odisha	622.05	50.00%
Bihar	139.31	11.20%
West Bengal	196	15.75%
Jharkhand	82.7	6.65%
Sikkim	17.4	1.40%
Unallocated	186.64	15.00%
	<b>1244.1</b>	<b>100%</b>

- (ii) Talcher-III project is located at about 20km from Angul (ISTS substation) and 10km from Meramundali/Meramundali-B (OPTCL substations). Accordingly, load flow studies have been performed for evolving evacuation system for Talcher-III project considering following two alternatives:

- (a) Talcher-III – Angul 400kV D/c (Triple Snowbird) line
- (b) Talcher-III – Meramundali-B 400kV D/c (Triple Snowbird) line

- (iii) Major load centres of Odisha are located near Angul, Meramundali, Khuntuni, Pandiabil, Paradeep, Duburi, Mendhasal and Bhadrak areas. In the Base Case study results i.e. without Talcher-III generation project, the said load centres of Odisha mainly draws about 1225MW power from Angul and 225MW from Baripada ISTS substations.

- (iv) Study results with two alternative systems has been discussed below:

**A. Talcher-III – Angul 400kV D/c (Triple Snowbird) line – ISTS system**

Three cases have been studied for this alternative.

**Case-A1:** *Base case with Talcher-III – Angul 400kV interconnection*

In this scenario, power flow on Angul – Meramundali 400kV D/c line is about 1500MW and that on Meramundali – Khuntuni 400kV D/c line is about 1300MW, which violates the N-1 criteria on these corridors. Moreover, Meramundali-B – Khuntuni line is lightly loaded. Further, the fault level at Meramundali and Angul is about 48kA and 64kA respectively, which exceeds the short time current rating of switchgears at these existing substations.

**Case-A2:** *Case-A1 along with by-passing of 400kV LILOs of Talcher – Meramundali and Meramundali – Bolangir at Angul*

In this scenario, power flow on Meramundali – Khuntuni 400kV D/c line is about 965MW and Meramundali-B – Khuntuni 400kV D/c line is about 145MW. There is highly uneven loading on these corridors. With disconnection of 400kV load centres of Odisha from Angul, power is supplied to load centres through Sundargarh – Rourkela – Talcher – Meramundali and Jamshedpur – Baripada – Dubri – Pandiabil – Medhasal 400kV corridors. However, the fault level at Meramundali reduces to about 26kA, which is within permissible limits.

**Case-A3:** *Case-A2 along with LILO of Meramundali – Angul/Bolangir at Meramundali-B*

In this scenario, power flow and fault levels are within permissible limits. Moreover, power *distribution* on Meramundali – Khuntuni and Meramundali-B – Khuntuni 400kV lines is quite balanced.

**B. Talcher-III – Meramundali-B 400kV D/c (Triple Snowbird) line – Intra-state system (by OPTCL)**

Three cases have been studied for this alternative too.

**Case-B1:** *Base case with Talcher-III – Meramundali-B 400kV interconnection*

In this scenario, power flow on Meramundali-B – Khuntuni 400kV D/c line is about 1210MW, which violates the N-1 criteria on this corridor. Moreover, power distribution on Meramundali – Khuntuni and Meramundali-B – Khuntuni 400kV lines is quite uneven. Further, the fault level at Meramundali is about 47.5kA, which exceeds the existing switchgear's short time current rating.

**Case-B2:** *Case-B1 along with by-passing of 400kV LILOs of Talcher – Meramundali and Meramundali – Bolangir at Angul*

In this scenario, power flow on Meramundali-B – Khuntuni 400kV D/c line is about 1220MW, which violates the N-1 criteria on this corridor. Power distribution on Meramundali – Khuntuni and Meramundali-B – Khuntuni 400kV lines is quite uneven. However, the fault level at Meramundali is reduced to about 27kA, which is within permissible limits.

**Case-B3:** Case-B2 along with LILO of Meramundali – Angul/Bolangir at Meramundali-B

In this scenario, power flow and fault levels are within permissible limits. Moreover, power distribution on Meramundali – Khuntuni and Meramundali-B – Khuntuni 400kV lines is reasonably balanced.

- (v) The details of studies for above cases are enclosed at **Annexure-34.1** and study results (i.e. line flows, SC level and losses) are summarised below:

Talcher-III Study Results									
Case No.	Case	Power Flow (in MW)			Odisha Loss (in MW)	Fault Current (in kA)			Remarks
		Angul-Meramundali (L1)	Meramundali-Khuntuni (L2)	Meramundali B-Khuntuni (L3)		Angul	Meramundali	Meramundali B	
0	Base Case (without Talcher-III)	1225 (N-1: 1000)	1235 (N-1: 1000)	125	142	58	46	8.1	- L1 and L2: N-1 violation - Meramundali: SC violations - Unbalanced loading on L2 and L3
<b>A</b> Talcher-III - Angul 400kV D/c line									
A1	Talcher-III - Angul	1500 (875+625)	1300 (N-1: 1050)	120	155	63.8	48	11.7	- L1: Base Case & N-1 violation - L2: N-1 violation - Angul & Meramundali: SC violations - Unbalanced loading on L2 and L3
A2	A1 + Angul LILO bypass	Tlch Ang Mera-175 Tlch Mera-300 Mera Boln-240	965	145	171	44.4	25.4	10.8	- Unbalanced loading on L2 and L3
A3	A2 + LILO of Mera-Boln at Mera B	Tlch Mera-335 Tlch Angl Mera-190 Mera Mera B-695 Mera B Boln-230	610	550	169	44.4	27	26.5	- Sufficient to meet system requirement - <b>Higher system losses compared to Case-B3</b>
<b>B</b> Talcher-III - Meramundali-B 400kV D/c line									
B1	Talcher-III -Meramundali-B	640 (373+268)	415	1210 (N-1: 1105)	150	59	47.5	17.8	- Unbalanced loading on L2 and L3 - L3: N-1 violation - Meramundali: SC violations
B2	B1 + Angul LILO bypass	Tlch Mera-115 Tlch Angl Mera - 65 Mera Boln-280	235	1220 (N-1: 1115)	151	38.6	27	16.9	- Unbalanced loading on L2 and L3 - L3: N-1 violation
B3	B2 + LILO of Mera-Boln at Mera B	Tlch Mera-65 Tlch Angl Mera-40 Mera Mera B-340 Mera B Boln-290	705	670	145	38.6	33	32.6	- Sufficient to meet system requirement - <b>Lower system losses compared to Case-A3</b>

- (vi) From the above study results, it may be inferred that, LILOs of Talcher – Meramundali and Meramundali – Bolangir 400kV S/c lines at Angul needs to be by-passed to control the fault level at Meramundali S/s under normal operating condition even without Talcher-III. The necessary arrangements to effect this is already under implementation wherein provision has been kept to restore the LILO of above line at Angul bus as and when required particularly in case of grid incidents like outage of lines/generations etc.

- (vii) After bypassing the LILOs under normal operating condition, Odisha would be devoid of ISTS power from Angul which was earlier feeding the load centres at Meramundali, Mendhasal and Duburi etc. Thus, in order to feed these load centres and new emerging load centres like Khuntuni, Narendrapur, Bhadrak and Paradeep, Talcher-III project may be connected to Meramundali-B. This would strengthen the Odisha grid, improve voltage profile in these areas and reduce losses in the Odisha system. Moreover, it is recommended to LILO Meramundali – Bolangir line at Meramundali-B so as to enable even loading of Meramundali – Khuntuni and Meramundali-B –



Khuntuni lines. Therefore, it can be concluded that the Case-B3 is a preferable scenario. Further, in the Case-B3, Odisha grid losses are about 25MW less compared to a similar case viz. Case-A3.

(viii) Based on above studied, the final evacuation system for Talcher-III project was proposed as follows:

- (a) Talcher-III – Meramundali-B 400kV D/c (Triple Snowbird) line
- (b) LILO of Meramundali – Angul/Bolangir 400kV S/c line at Meramundali-B
- (c) By-passing of LILOs of Meramundali – Bolangir and Talcher – Meramundali 400kV lines at Angul (by suitable switching arrangement at substation, which is under implementation)

(ix) NTPC stated that 50% power of the Talcher-III generation project has been allocated to Odisha, 35% to various ER beneficiaries as per the Gadgil formula (Bihar, West Bengal, Jharkhand and Sikkim) and balance 15% remains unallocated. If Talcher-III is connected to Odisha STU, then other states will have to pay STU charges in addition to ISTS charges. In case Talcher-III is connected to ISTS, Odisha has to pay the ISTS charges.

(x) Representative of CTU stated that the evacuation proposed is based on technical considerations only, but not based on commercial considerations.

(xi) AGM, NTPC further requested to connect one 400kV circuit from Talcher-III to Meramundali and another to Meramundali-B so that reliability of Talcher-III evacuation improves (considering substation outage). During the meeting the proposal was studied and it was observed that power flows are within limits.

(xii) The proposal of NTPC was agreed in the meeting for evacuation of power from Talcher-III project.

(xiii) Representative of Odisha informed that the implementation of Talcher-III has been deferred in a high level meeting of Odisha Government.

(xiv) Representative of NTPC stated that cases like Talcher-III, where allocation of power is 50% or more to home state (remaining allocation is to other states) are creating complexities in commercial terms (regarding connectivity with ISTS/STU), and the same may be addressed.

(xv) Members suggested that NTPC may file a general petition to CERC to address the above issues, which are likely to be encountered in future.

(xvi) In view of above, the following was agreed in principle in the CEA meeting held on 18-08-2017:

- (a) By-passing LILOs of Meramundali – Bolangir and Talcher – Meramundali 400kV S/c lines at Angul (by suitable switching arrangement which is under

implementation) as and when the scheme is implemented so as to limit fault current at Meramundali.

- (b) Optimum utilization of 4 line bays (bays of above LILO) available at Angul substation needs to be explored in due course of time by shifting bypassing arrangement outside the substation.
- (c) LILO of Meramundali – Angul/Bolangir 400kV S/s line at Meramundali-B – by Odisha under intra-state scheme
- (d) The immediate evacuation of Talcher-III project is as mentioned below:
  - (i) Talcher-III – Meramundali / Meramundali-B 400kV D/c (Triple Snowbird) line (one circuit terminated at Meramundali and other circuit terminated at Meramundali-B)

***Note:** However, as the implementation of Talcher-III has been deferred in a high level meeting of Odisha Government, therefore it was decided that evacuation system for Talcher-III may be planned after finalization of its implementation schedule as the transmission system is undergoing continuous changes.*

- 34.3 Representative of Odisha informed that the implementation of Talcher-III has been deferred in a high level meeting of Odisha Government. Therefore, NTPC might plan for the evacuation after getting clearance from the Government of Odisha.
- 34.4 Representative of NTPC stated that NTPC has not received any official communication from Government of Odisha regarding postponement of implementation of Talcher-III. He further informed that NTPC has started tendering process for Talcher-III and without finalization of voltage level and evacuation, it would be difficult for them while tendering. Representative of Odisha stated that NTPC should not have started the process of tendering without taking clearance from Government of Odisha.
- 34.5 In regard to commercial issues for evacuation of power at STU or ISTS point, representative of Odisha suggested that these issues should be discussed after getting clearance from Government of Odisha.
- 34.6 MS, ERPC stated that in the state SCM meeting, states other than Orissa have informed that they would not share the Odisha intra-state transmission charges for drawl of their share from Talcher-III (2x660MW) ISGS project.
- 34.7 Representative of CTU stated that evacuation proposal for Talcher-III is based on technical considerations, not on commercial considerations. Unit segregation of Talcher-III is a solution for commercial issues, however unit segregation is not possible as the allocation to the states are from both the units.
- 34.8 Representative of Odisha stated that Talcher-III is situated in Odisha, in case the project is connected to ISTS, they have to bear huge losses on account of PoC charges.

34.9 Members opined that as the implementation of Talcher-III has been deferred in a high level meeting of Odisha Government, therefore the evacuation system for Talcher-III may be planned and finalized in Standing Committee Meeting after finalization of its implementation schedule.

**35. Approval for construction of 2 nos. 400/220kV substation at Bhadrak and Paradip by OPTCL with revised connectivity.**

35.1 Representative of OPTCL informed that, in the 18th standing committee meeting held on 13th June'2016 at Kolkata, in principle approval were given for two nos. of 400/220kV intra-state substations at Bhadrak and Paradip for the Plan period 2017-2022. The connectivity plan needs to be revised.

35.2 The revised connectivity plan for 400/220kV Bhadrak and Paradip intra-state substation is given below.

- LILO of Pandiabil – Baripada (Kuchei) 400kV D/c line at 400/220kV S/s at Bhadrak
- LILO of Duburi – Bhadrak 220kV D/c line at Bhadrak
- New Duburi – Paradip 400kV D/c line
- Paradip – Pratapsasan 220kV D/c line

**PART-B: The future plan (for information only)**

- Establishment of 400/220kV sub-station at Dhamara
- Dhamara – Bhadrak 400kV D/c line
- Dhamara – Paradip 400kV D/c line
- Paradip – Pandiabil 400kV D/c line

35.3 In regard to time frame for implementation of 400/220kV sub-station at Dhamara, OPTCL informed that the S/s is planned to be implemented beyond 2021-22.

35.4 Director (PSPA-2) queried regarding transformation capacity of these substations. Representative of OPTCL stated that transformation capacity of these substations would be 2x500MVA along with 1x80MVAR bus reactor.

35.5 Representative of CTU stated that 80MVAR reactor is not much effective in controlling voltage as short circuit level is in increasing trend. Therefore, it would be better to have 125MVAR bus reactor.

35.6 Members agreed for 2x500MVA, 400/220kV substations along with 1x125MVAR bus reactor at Bhadrak and Paradip with the above connectivity by OPTCL as intrastate transmission system to be implemented by OPTCL. It was also decided that OPTCL may obtain approval for 400/220kV substation at Dhamara in future SCM meetings once its implementation schedule is firmed up.

**36. Approval for connectivity of 400/220kV sub-station at Narendrapur to 400/220kV Jaynagar/ Jeypore (PG) with a 400kV D/c line in place of 400kV Angul –Narendrapur – Gazuwaka D/c line**

- 36.1 Director (PSPA-II) informed that in the 18th standing committee meeting, Angul-Narendrapur-Gajuwaka 400kV link was proposed as an additional link to Jeypore- Gajuwaka 400kV link for enhancement of export to Gajuwaka up to 1000MW. Whereas with the commissioning of 765kV D/c Angul-Srikakulam link, an additional path to Gajuwaka has been created through Angul – Srikakulam – Vemagiri – Gajuwaka and 765kV D/c Angul-Srikakulam line would further be connected to Load centres of Andhra Pradesh (SR) through 765kV and 400kV lines.
- 36.2 Representative of OPTCL has proposed following revised connectivity plan for 400/220kV S/s at Narendrapur (intra-state), the sub-station is already approved in the 18<sup>th</sup> standing committee meeting.
- (a) 400kV D/c line Pandiabil (PG) to Narendrapur.
  - (b) 400kV D/c line from Narendrapur to Jeypur PG to be LILLOed at 400 kV Switching Station at Theruvali.
  - (c) The Theruvali Switching Station to be converted to a 400/220kV S/S when the demand grows.
- 36.3 Representative of OPTCL stated that Narendrapur – Pandiabil – Mendhasal – Khuntuni – Meramundali/Meramundali-B 400kV D/c line with the approval of Narendrapur – Jeypore (POWERGRID) 400kV D/c link will improve the fault level. With these interconnections, the reliability of the system would also increase as Khuntuni – Mendhasal – Pandiabil – Narendrapur – Theruvali – Jeypore – Bolangir – Meramundli/ Meramundali-B 400kV ring would be formed. Hence, Angul – Narendrapur – Gajuwaka 400kV link may be dropped and in lieu of this the Narendrapur – Jeypore (POWERGRID) link, proposal of Odisha may be agreed.
- 36.4 Representative of CTU stated that The Gazuwaka HVDC back to back converter station has a capacity of 2x500MW. Power is fed to this S/s through Jeypore – Gazuwaka 400kV D/c line. Presently, the flow through the HVDC station is restricted to 600-650MW due to feeds to Gazuwaka and Jeypore substations through weak transmission network (comprising of long 400kV lines).
- 36.5 He further stated that Jeypore S/s is fed from two 400kV lines viz. Angul/Bolangir – Jeypore and Indravati – Jeypore 400kV S/c lines (ACSR Twin Moose). Outage of any of these lines limits the power feed to Jeypore and Gazuwaka substations, thereby limiting the full utilisation of Gazuwaka HVDC. Thus, under outage of one circuit of the D/c line Gazuwaka HVDC cannot be operated at its rated capacity of 1000MW. Therefore, to fully utilize the capacity of HVDC station additional feed to Gazuwaka through the following lines were proposed:
- Angul – Narendrapur (New) 400kV D/c (Triple Snowbird) line
  - Narendrapur (New) – Gazuwaka 400kV D/c (Triple Snowbird) line
- 36.6 Director(PSPA-2), CEA stated that sufficient additional capacity would be available in Angul-Srikakulam 765kV D/c (Hexa Zebra) line (ER-SR link) by

2021-22 time frame, this line would further be connected to Load centres of Andhra Pradesh (SR) through 765kV and 400kV lines. Loading of the line by 2021-22 time frame is expected to be around 1100-1600MW, whereas the transmission capacity of the above inter-regional link is around 4200MW.

- 36.7 It was also informed that implementation / scrapping of Talcher – Behrampur – Gajuwaka 400kV D/c ISTS line is not yet decided and it is under jurisdiction of court.
- 36.8 Director (PSPA-2), CEA stated that a meeting regarding the above agenda item was held on 18.08.2017 at CEA with CTU & Odisha. In the meeting, it was agreed to take up 400kV D/c line from Narendrapur to Jeypore (PG) and LILO of this line at 400kV switching station at Theruvali in the SCM of ER in place of proposed Angul – Narendrapur – Gajuwaka 400kV D/c ISTS line. The proposal would be executed by OPTCL as intra-state system.
- 36.9 After detailed deliberations, members decided for a separate meeting at CEA to evolve a comprehensive system with implementation time schedule for evacuation plan of 3x800MW Power Plant of M/s OTPCL (Odisha Thermal Power Corporation Ltd.) at Kamakshyanagar, Odisha with Narendrapur – Theruvali – Jeypore (under intra-state). After finalisation, the issue may be taken up for further discussion in the subsequent Standing Committee Meeting.
- 37. Proposed evacuation plan of 3x800MW Power Plant of M/s OTPCL (Odisha Thermal Power Corporation Ltd.) at Kamakshyanagar, Odisha: Agenda by OPTCL**
- 37.1 Representative of OPTCL informed that M/s OTPCL plans to establish a 3x800MW generating plant at Kamakshyanagar by the Year 2021-22. OPTCL has planned to evacuate full power with the following transmission elements, to be implemented under intra-state scheme by OPTCL.

#### **765kV Connectivity**

- The 765kV Switching Station of Kamakshyanagar to be connected with Angul PG, with 765kV D/c line.
- A 765/400kV Sub-station at Begunia with 765kV D/c line from Kamakshyanagar to Begunia.

#### **400kV connectivity at 765/400kV Begunia**

- 400kV D/c line Mendhashal – Khuntuni to be LILoed at 765/400 kV Begunia.
  - 400kV D/c line Pandiabil – Narendrapur to be LILoed at 765/400 kV Begunia.
- 37.2 OPTCL informed that power evacuation from M/s OTPCL would be through 765/400kV Begunia S/s and 765/400kV Angul S/s. As per proposal Begunia would be further connected to LILo of Mendhashal - Khuntuni D/c & LILo of Pandiabil - Narendrapur D/c 400kV lines for evacuation of power to the load centres at Mendhashal, Khuntuni, Narendrapur, Pandiabil and Duburi. The

connectivity with Angul would add stability to the evacuation plan. OPTCL requested for providing two line bays at Angul at 765kV level for Odisha.

- 37.3 The detailed single line diagram of the Proposed Plan with length of transmission line is at **Annexure-37.1**. Schematic of 765kV and 400kV transmission network with load flows of Odisha State for 2021-22 is at is at **Annexure-37.2**.
- 37.4 In the meeting held on 18.08.2017 at CEA the evacuation system of Talcher-III project of NTPC and proposals of OPTCL were discussed with POWERGRID (CTU), POSOCO, OPTCL and GRIDCO. The system studies were performed after the meeting as per the deliberation in the meeting and Odisha's various proposals. The study results (load flow, observations and fault current) are at **Annexure 37.3**.
- 37.5 On a query regarding time frame for implementation of generation project, OPTCL informed that the generation plant may come up during 2022-27. OPTCL further informed that Switching Station at Kamakhyanagar may be constructed before the commissioning of M/s OTPCL generation project. And after commissioning of generation project, the same may be connected to Kamakhyanagar Switching Station.
- 37.6 Member (Power System), CEA stated that after commissioning of 3x800MW M/s OTPCL generation project, Odisha would be surplus in generation and the excess generation would be injected to ISTS network. For transfer of surplus power outside the state, Odisha would need to apply for LTA for transfer through ISTS. Accordingly, he suggested that a comprehensive study may be carried out with all concerned.
- 37.7 In view of the above discussions, members decided that a separate meeting may be held at CEA to discuss the issues and finalise the power evacuation system for Kamakhyanagar (3x800MW) generation project. The evacuation system finalised after discussion, may be taken up for further discussion in the subsequent Standing Committee Meeting.

### **38. Evacuation of power from 2x660MW project of OPGC**

- 38.1 Representative of OPTCL informed that the 2x660MW generating plant of OPGC is in advance stage of commissioning. The evacuation plan envisaged was as follows:
- (a) Earlier, out of 2 units of OPGC, one unit was connected to STU and the second was connected to ISTS for evacuation of power to Odisha through STU network and to remaining beneficiaries of ER through ISTS. Accordingly, bus split was planned at OPGC. One 400kV D/c line was planned to be connected to Lapanga from state allocated unit and another unit was proposed to be connected to Sundargarh (Jharsuguda) through 400kV D/c (triple snowbird) ISTS line. The ISTS line is already under implementation through TBCB and is in advanced stages of commissioning.

(b) Now, the total power of OPGC has been allocated to Odisha. The matter was discussed in a meeting held at CEA on 18-08-2017. Therein, Odisha mentioned that since Odisha is going to avail the entire power, the OPGC – Jharsuguda 400kV D/c (Triple Snowbird) ISTS line may be transferred from M/s Odisha Generation Phase-II Transmission Limited to M/s OPTCL. Thus, it will be a STU line and Odisha would not have to bear ISTS charges for drawl of its share of power. It was decided that the matter may be taken up for discussion in the SCM.

38.2 Representative of CTU stated that CERC has given transmission licence to M/s Odisha Generation Phase-II Transmission Limited for implementation of OPGC – Jharsuguda 400kV D/c (Triple Snowbird) ISTS line. The suggested change in status of the line from ISTS to STU due to proposed takeover by OPTCL may be taken up with CERC. He further informed that OPGC is having 600MW LTA to ISTS grid. In case entire power allocation is made to Odisha then OPGC would need to withdraw ISTS Connectivity and relinquish ISTS LTA with applicable commercial liabilities.

38.3 Alternatively, representative of Odisha requested that approval may be granted to construct two D/c line from OPGC to Lapanga for evacuation of entire power to Odisha.

38.4 Members felt that as the issue of transfer of ISTS asset to STU is not in the purview of standing committee, the same be taken up by OPTCL at an appropriate forum.

**39. Connectivity of Railways TSS with ISTS network for Ludhiana-Delhi-Sonenagar routes**

39.1 Representative from Railways mentioned that, Indian Railways is planning to connect its TSSs between Ludhiana-Delhi-Sonnenagar routes of Railways by way of construction of associated infrastructure including transmission lines and bay extension work at ISTS points preferably at 220kV level.

39.2 Railway Board, vide its letter no. 2012/Elect (G) /150/1 Pt – II dated 28.12.2016, has requested for connectivity to railways from various ISTS points. Power requirement of Railways from the nearby proposed ISTS points is as follows:

CONNECTIVITY SCHEME OF TSS ALONG LUDHIANA - DELHI- SONNAGAR ROUTE					
Sl. No.	PGCIL GSS	Connectivity required at (kV)	Railway TSS to be supplied	Grid Voltage at TSS (kV)	Tentative load requirement (MW)
1	Abdullapur	220	Jagadhari-I	220	50
2			Jagadhari-II	220	
3			Tapri	132	
4			Muzaffarnagar	132	
5	Meerut	220	Jaranda Nara	132	50
6			Hapur	132	
7			Gulaothi	132	
8			Wair	132	
9	* Pasauli (Sasaram)	220	Durgaoti	1 32	75

10			Deoria	132	
11			Chandiapur	132	
12			Gadhion	132	
13			Jeonathpur	132	
14			Chunar	132	

39.3 A meeting regarding Connectivity of Railways TSS with ISTS Network at Abdullapur, Meerut and Sasaram for Ludhiana-Delhi-Sonnagar route was held in CEA on 21.07.2017. The following were decided in the meeting.

- (i) *As no representative from Bihar was present in the meeting no decision could be taken in respect of connectivity to Railways TSS at Sasaram substation.*
- (ii) *Railways would utilize existing two number of 220 kV bays at Abdullapur substation (presently used for 220 kV supply to Jagadhari TSS) to meet their additional traction load requirement. The required technical upgradation of the 220 kV line (presently only two phases has been strung) would be carried out by Railways subject to fulfilment of all the existing agreements of HVPNL with Railways for this line.*
- (iii) *Two nos. of 220 kV (GIS) bays at Meerut 400/200kV substation along with establishment of 220/132kV, 2x100 MVA GIS in the premises of Meerut 400/220 kV substation was agreed for providing connectivity to Railways. The cost of above works shall be borne by Railways. Railways to implement 132 kV D/c interconnection from Meerut (PG) to their 132 kV substation.*

39.4 Representative of ERPC stated that it would be more appropriate to discuss the issue in a special meeting at CEA/ERPC.

39.5 Members agreed for above.

**40. Additional outlets from Darlipalli STPP and North Karanpura STPP for mining activities**

40.1 Representative of NTPC informed that the Associated Transmission System of Darlipali STPP stage-I (2x800MW) project was finalized in 13<sup>th</sup> ER Standing Committee Meeting and LTA meeting held on 12<sup>th</sup> February 2012 with the following Evacuation system:

- Darlipali – Jharsuguda (Sundergarh Pool) 765kV D/c line

40.2 Coal for the project is planned to be sourced from Dulanga captive coal mine allocated to NTPC by Gol which is located at a distance of 10km from the project.

40.3 NTPC had approached OPTCL for power supply to Dulanga mine as HT consumer however it has been asked by GRIDCO to draw the power for this mine from GRIDCO share of power in Darlipali directly from the generation switchyard in view of vicinity to the generation project. As such suitable arrangement has been made in the auxiliary power supply system of the project for providing 15 MVA power to the linked mine at 33kV voltage level.



- 40.4 Further, GRIDCO has also allotted additional 15MVA of power for Manoharpur coal mine of OCPL(in vicinity of Dulanga mines) and has asked them to draw power directly from DSTPP generation switchyard as being done in case of Dulanga mines. It may be noted that these load centres are radially fed from the generation switchyard.
- 40.5 Further, for meeting the power supply requirement of captive Chatu Bariatu & Kerandari and Pakri Barwadih coal mines, 2 nos. 220kV feeder from North Karanpura project has been planned. Power from NKSTPP to mines also shall be drawn in radial mode.
- 40.6 In view of the above NTPC requested that above drawls may be considered as drawl by GRIDCO/ Jharkhand from their share of allocated power from Darlipalli and North Karanpura projects. Also required interface energy meters shall be installed by CTU.
- 40.7 Members expressed that this issue does not come under the purview of Standing Committee. MS, ERPC advised that NTPC could place this issue in the next OCC meeting of ERPC. NTPC agreed for the same.

**41. Interim arrangement for power evacuation from Nabinagar TPP (3X660MW)**

- 41.1 Director (PSPA-2) said that, the 1st unit of Nabinagar TPP (3x660MW) is in advance stage of completion and anticipated to be synchronized in Oct' 17. The scheduled commissioning of this unit is in Nov' 17. The evacuation system for Nabinagar TPP includes Nabinagar - Gaya 400kV D/C (Quad) transmission line which was awarded by POWERGRID in Apr'16 with commissioning schedule as 38 months. However, POWERGRID had agreed to complete the line on best effort basis matching with commissioning of the 1st unit of the generation project. The anticipated date of completion of the line is Dec'17 which may be delayed further and hence the completion schedule of the line may not match with commissioning date of 1st unit of Nabinagar TPP. It is, therefore requested that interim arrangement of evacuation of power for Nabinagar TPP may be evolved.
- 41.2 Representative of POWERGRID stated that Nabinagar-II – Gaya 400kV D/c line is crossing the Daltanganj – Sasaram 400kV D/c line. Sasaram to crossing-point and Nabinagar-II to crossing point lines are under advance stages of completion and the two sections can be joined to form Nabinagar-II – Sasaram 400kV S/c line as interim arrangement for connection of Nabinagar-II to grid. After completion of Nabinagar-II – Gaya line, the interim arrangement would be removed.
- 41.3 Members agreed for the interim arrangement for Nabinagar-II as proposed by POWERGRID.

**42. Revision in capacity of 4<sup>th</sup> 220/132kV ICT at Rangpo S/s under ERSS-XX**

- 42.1 Representative of POWERGRID informed that installation of 4th 220/132kV, 160MVA ICT at Rangpo S/s was planned under ERSS-XX in order to meet the N-1 reliability criteria in the 18th Standing Committee Meeting of ER. About

250MW power from three generation projects viz. Chuzachen (99MW), Bhasmey (51MW) and Dikchu (98MW) would be injected at 132kV level at Rangpo S/s.

- 42.2 POWERGRID has informed that 220/132kV, 160MVA ICT which is about 89-109MT cannot be transported to Rangpo S/s, as the maximum load bearing capacity of the bridge en-route Siliguri to Rangpo is only about 80MT. Thus, it is proposed that 220/132kV, 100MVA ICT may be installed at Rangpo in place of 220/132kV, 160MVA ICT as the 4<sup>th</sup> ICT under ERSS-XX. As such, the 220/132kV, 4x100MVA transformation capacity would be enough to meet the N-1 security criteria.
- 42.3 Members agreed for the revision in scope of work from 220/132kV, 160MVA ICT to 220/132kV, 100MVA ICT to be installed at Rangpo as the 4<sup>th</sup> ICT under already approved ERSS-XX scheme.

#### **43. Bus splitting of POWERGRID sub-stations**

- 43.1 MS, ERPC stated that bus splitting at 400kV Maithon, Durgapur and Biharsharif substations were agreed in the standing committee. Latest status is that the bus splitting of these substations have been completed. During third party protection audit of 400kV Maithon S/s on 18th May 2017, it was observed that bus splitting scheme at 400kV Maithon S/s has been commissioned, but not in service. Subsequently in 134th OCC, it was informed that the bus splitting scheme at 400kV Maithon and Biharsharif would be operationalized after getting the consent from CTU.
- 43.2 Representative of CTU informed that the study for implementation of bus-splitting scheme at above 3 locations is in process. In view of changed grid scenario and the action plan for commencing the bus-split operation would be indicated shortly.
- 43.3 Members noted and requested CTU to provide action plan for commencing the bus-split operation at the above substations.
- 43.4 CTU vide letter dated 11-09-2017 has mentioned that Biharsharif and Maithon 400kV bus split arrangement may be operationalized with immediate effect. Though fault current at Durgapur has almost reached the design limit, with the operationalization of split bus at Kahalgaon (expected by Dec 2018) and the Farakka bypass scheme (approved in 19th SCM), the fault current level at Durgapur reduces to about 37kA. Therefore, the bus splitting at Durgapur may be operationalized at a later date.

#### **44. LILO Connection of 132kV Sonenagar-Rihand (UP,NR) Circuit-I at NPGC, Nabinagar for providing startup power to NPGC**

- 44.1 MS, ERPC stated that during 131<sup>st</sup> OCC meeting of ERPC, BSPTCL informed that NPGC, Nabinagar has applied for 65 MVA start-up power and initially they will draw around 5-10MW power through 132kV Sonenagar-Rihand-I line LILOed at NPGC, Nabinagar. It was also pointed that 132kV Sonenagar-Rihand (UP,NR) Circuit-I is lying idle charged since last 5-6 years and presently it remains

charged on no load from Sonenagar end & open at Rihand (UP) end. It was informed that NPGC, Nabinagar will only draw startup power for commissioning activities through the above LILO as an interim arrangement and injection of power/trial-run will be done after the completion of 400kV ATS of NPGC, Nabinagar. The issue was also discussed with CTU and CEA. CEA, vide their letter 69/2/PSPA-II/2017/362, dated 08.05.2017, communicated their no-objection. CTU also expressed the same.

44.2 ERPC vide fax message no. 259 dated 09.05.17 has given the confirmation to SLDC, UPPTCL with a copy to all other utilities that as per the decision of OCC, NPGC is going to start availing the start-up power from BSPTCL by closing Sonnagar-NPGC 132kV LILO section of 132kV Sonnagar-Rihand-I line keeping the line open at Rihand end. It was also mentioned that it is an interim arrangement subject to post facto approval of Standing Committee of ER in its forthcoming meeting.

44.3 Members agreed for post facto approval for the said interim arrangement till completion of 400kV ATS of Nabinagar-II. It was also decided that upon completion of 400kV ATS of Nabinagar-II, the interim arrangement shall be removed.

#### **45. OPGW and Communication System for new ISTS system**

45.1 **Representative of POWERGRID** stated the following:

- (i) Establishment of data and voice connectivity for new substation with RLDC is mandatory for energizing the transmission system as per CERC guidelines.
- (ii) Presently, new transmission systems are being implemented on TBCB route. The TSP for execution of transmission line has to provide OPGW from gantry to gantry for communication purpose. Similarly TSP executing the substation work shall be responsible for installation of STM-16 communication equipments along with Fibre Optic Approach cable and FODP etc. for OPGW connectivity.
- (iii) While finalizing the RfP of new transmission system, followings provisions with regard to data and voice connectivity are required:
  - (a) **Transmission line:** Certain transmission system is being implemented by doing LILO of existing line which is not having OPGW. In order to provide OPGW connectivity to LILO substation, OPGW on main line is essentially required and is to be provided by the owner of the transmission line. However, cost for the same may be booked in the project cost of the new Transmission System.
  - (b) **Sub-Station:** The communication equipment (SDH and PDH, PMU, SAS/RTU, Approach cable & FODP) for new substation are included in the RfP document. But the communication equipment of other end of transmission line which is under ownership of POWERGRID/other utility

is not covered. In these cases, end to end communication establishment will not be possible unless the communication equipment including approach cable and FODP for other end is provided. It is proposed that the provision of communication equipment (STM-16) including approach cable and FODP at the other end may be taken up by the respective owners. However, cost for the same may be booked in the project cost of the new Transmission System.

- 45.2 Members agreed regarding requirement of OPGW on main line and associated communication equipment at terminal substations. However, regarding implementation modalities may be taken up at appropriate forum/Empowered committee.

Meeting ended with vote of thanks to chair.

\*\*\*

**Annexure-I**

**List of the participants of 19<sup>th</sup> Standing Committee Meeting on Power System Planning of Eastern Region held on 01-09-2017 at Kolkata.**

Sl. No.	Name	Designation	Mobile No.	E-Mail
<b>Central Electricity Authority (CEA)</b>				
1.	Shri P.S.Mhaske	Member (Power System)		
2.	Shri S.K. Ray Mohapatra	Chief Engineer	9818527857	<a href="mailto:skrmohapatra@rediffmail.com">skrmohapatra@rediffmail.com</a>
3.	Smt. Rishika Sharan	Director	9868021299	<a href="mailto:rishika_sh@yahoo.com">rishika_sh@yahoo.com</a>
4.	Shri U.M. Rao Bhogi	Dy. Director	8800641444	<a href="mailto:umarao236@gmail.com">umarao236@gmail.com</a>
<b>Eastern Regional Power Commission (ERPC)</b>				
1.	Shri A. Bandopadhyay	Member Secretary	9433068533	<a href="mailto:mserpc.power@nic.in">mserpc.power@nic.in</a>
2.	Shri D K Bauri	EE	9883617236	<a href="mailto:Eeop.erpc@gov.in">Eeop.erpc@gov.in</a>
<b>Railways</b>				
1.	Shri Punit Agrawal	Director(EPS), MoR	9910487331	<a href="mailto:deaps@rb.railnet.gov.in">deaps@rb.railnet.gov.in</a>
2.	Shri J C S Bora	GM, REMCL	9205060038	<a href="mailto:jsbora@rites.com">jsbora@rites.com</a>
3.	Shri Ramesh Maurya	Dy. CGM, DFCL	7897003135	<a href="mailto:rmaurya@dtcc.co.in">rmaurya@dtcc.co.in</a>
<b>Central Transmission Utility (CTU)</b>				
1.	Dr. Subir Sen	COO (CTU-Plg & SG)	9650293185	<a href="mailto:subir@powergridindia.com">subir@powergridindia.com</a>
2.	Shri Ashok Pal	GM (CTU-Plg)	9910378105	<a href="mailto:ashok@powergridindia.com">ashok@powergridindia.com</a>
3.	Shri Dilip Rozekar	AGM (CTU-Plg)	9910378105	<a href="mailto:drozekar@powergridindia.com">drozekar@powergridindia.com</a>
4.	Shri Ramachandra	DGM(CTU-Plg)	9910378128	<a href="mailto:ramachand@powergridindia.com">ramachand@powergridindia.com</a>
5.	Shri Manish Ranjan Keshari	Sr. Engineer (CTU-Plg)	8826094864	<a href="mailto:manish.keshari@powergridindia.com">manish.keshari@powergridindia.com</a>

Sl. No.	Name	Designation	Mobile No.	E-Mail
6.	Shri Anupam Kumar	Engr (CTU-Plg)	9599814165	<a href="mailto:anupamk@powergridindia.com">anupamk@powergridindia.com</a>
<b>Power Grid Corporation of India Ltd (PGCIL)</b>				
1.	Shri Bharat Bhushan	ED (ER-II)	9403777811	<a href="mailto:bharatbhushan@powergridindia.com">bharatbhushan@powergridindia.com</a>
2.	Shri S N Sahay	ED (ER-I)	9431815043	<a href="mailto:snsahay@powergridindia.com">snsahay@powergridindia.com</a>
3.	Shri Sunil Agrawal	ED (LD&C)	7042195168	<a href="mailto:sunila@powergridindia.com">sunila@powergridindia.com</a>
4.	Shri S K Pramanik	GM (Projects)	7603037367	<a href="mailto:skpramanik@powergridindia.com">skpramanik@powergridindia.com</a>
5.	Shri A. Sensarma	AGM (Asset Management)	9717296934	<a href="mailto:asensarma@powergridindia.com">asensarma@powergridindia.com</a>
6..	Shri S. Chattopadhyay	AGM (RP&IT)	9434742008	<a href="mailto:schattopadhyay@powergridindia.com">schattopadhyay@powergridindia.com</a>
7.	Shri S.J. Lahiri	DGM(Engg.)	9434742001	<a href="mailto:sjlahiri@powergridindia.com">sjlahiri@powergridindia.com</a>
8.	Shri Arvind Prasad	DGM(Engg.)	9431815687	<a href="mailto:arvindprasad@powergridindia.com">arvindprasad@powergridindia.com</a>
9.	Shri S N Ghosh	Asst, GM(ULDC)	9434740016	<a href="mailto:Sngghosh@powergridindia.com">Sngghosh@powergridindia.com</a>
10.	Shri A.K. Dash	CM (OS)	9434740029	<a href="mailto:anjandas@powergridindia.com">anjandas@powergridindia.com</a>
11.	Shri P. Ghosh.	Dy. Mgr(AM)	9434748263	<a href="mailto:partha.ghosh@powergridindia.com">partha.ghosh@powergridindia.com</a>
12.	Shri S. Goswami	Dy. Mgr. (ER&S IT)	9434748366	<a href="mailto:sudipgoswami@powergridindia.com">sudipgoswami@powergridindia.com</a>
<b>Odisha</b>				
1.	Shri N.C. Swain	CGM, OPTCL	9438907901	<a href="mailto:Sgm.cons1.bbs@optcl.gov.in">Sgm.cons1.bbs@optcl.gov.in</a>
2.	Shri A.K. Banngi	AGM, OPTCL	9438907352	<a href="mailto:ele.akbanerjee@optcl.co.in">ele.akbanerjee@optcl.co.in</a>
3.	Shri Upendra Nath Mishra	CGM(PP), GRIDCO Ltd	9438907774	<a href="mailto:Ssgm.pp@gridco.co.in">Ssgm.pp@gridco.co.in</a>
4.	Shri Umakanta Sahoo	DGM(EI), GRIDCO Ltd	9437185507	<a href="mailto:u.sahoo.pure@gmail.com">u.sahoo.pure@gmail.com</a>
<b>Bihar State Power Transmission Corporation Ltd. (BSPTCL)</b>				
1.	Shri Bhaskar Sharma	Director (Project)	9771496900	
2.	Smt. Shweta Rani	AEE	7635092519	<a href="mailto:Srani828@gmail.com">Srani828@gmail.com</a>

Sl. No.	Name	Designation	Mobile No.	E-Mail
3.	Smt. Sarita Kumari	AEE	7635092523	<a href="mailto:SaritaK0506@gmail.com">SaritaK0506@gmail.com</a>
<b>Sikkim</b>				
1	Shri K.B.Kunwar	Principal Chief Engineer	9434032924	<a href="mailto:kunwarkb@gmail.com">kunwarkb@gmail.com</a>
<b>National Transmission Power Corporation (NTPC)</b>				
1.	Shri Subhash Thakur	Addl GM (PE-Elect.)	9650991067	<a href="mailto:subhashthakur@ntpc.co.in">subhashthakur@ntpc.co.in</a>
<b>West Bengal State Electricity Transmission Corporation Limited (WBSETCL)</b>				
1.	Shri V. Roy	Director(Op)	9434910015	<a href="mailto:Vabya_60@yahoo.com">Vabya_60@yahoo.com</a>
2.	Shri A. Karmakar	CE(CPD)	9434910090	<a href="mailto:asik.karmakar@wbsetcl.in">asik.karmakar@wbsetcl.in</a>
3.	Shri P.K.Kundu	CE, SLDC	9434910030	<a href="mailto:wbsldc@gmail.com">wbsldc@gmail.com</a>
4.	Shri Sajal Kumar Bag	SE, CPD	9434910093	<a href="mailto:sajal.bag@wbsetcl.in">sajal.bag@wbsetcl.in</a>
<b>Damodar Valley Corporation</b>				
1.	Shri A. Debnath	Executive Director (System)	9831954257	<a href="mailto:dir.system@dvc.gov.in">dir.system@dvc.gov.in</a>
2.	Shri Suman Kumar Bose	CE(SPE)	8145524994	<a href="mailto:Suman.bose@dvc.gov.in">Suman.bose@dvc.gov.in</a>
3.	Shri Dinesh Kumar Singh	Dy. CE (E)/ SPE	9434535601	<a href="mailto:Dinesh.singh@dvc.gov.in">Dinesh.singh@dvc.gov.in</a>



भारत सरकार  
Government of India  
विद्युत मंत्रालय  
Ministry of Power  
केंद्रीय विद्युत प्राधिकरण



[ISO: 9001:2008]

Central Electricity Authority  
विद्युत प्रणाली योजना एवं मूल्यांकन प्रभाग-2  
Power System Planning & Appraisal Division-II  
सेवा भवन, रा. कृ. पुरम, नयी दिल्ली -110066  
Sewa Bhawan, R. K. Puram, New Delhi-110066

No. 77/3/PSPA-II/2016-58-62

Dated 27-01-2017

To

COO(CTU-Plg), Power Grid Corp. of India Ltd. "Saudamini", Plot No.2, Sector-29, Gurgaon 122 001, Haryana. FAX : 95124-2571932	Chief Engineer, Central Planning Department, West Bengal State Electricity Trans. C. Ltd ( WBSETCL), Vidyut Bhawan ( 9th Floor), Block-DJ, Sector-II, Bidannagar, Kolkata-700091	CEO, PFC Consulting Ltd, First Floor, Urjanidhi, 1, Barakhamba Lane, Connaught Place, New Delhi -110001 (Fax- 011-23456170)
---	--	---

**Subject:** Minutes of the meeting regarding termination of 400kV lines at Jeerat(WBSETCL) S/s under the ERSS-XV and ERSS-XVIII scheme.

Sir,

The minutes of the meeting held on 14-12-2016 at CEA, Sewa Bhawan, R K Puram, New Delhi regarding above subject is enclosed.

Yours faithfully,

*Rishika Sharan*  
27/01/2017  
(Rishika Sharan)  
Director (PSPA-II)

Copy to:

- 1 Managing Director,  
WBSETCL, Vidyut Bhawan,  
5th Floor, Block-D, Bidhannagar  
Sector-II, Kolkata – 700091,
- 2 PPS to Member(PS), CEA

With request to consider and convey approval on the option No# 3, as agreed in above meeting



**Minutes of the meeting regarding termination of 400kV lines at Jeerat (WBSETCL) S/s under the ERSS-XV and ERSS-XVIII scheme held on 14.12.2016 at CEA.**

List of participant is enclosed at Annexure-1.

1. Chief Engineer (PSPA-II), CEA welcomed the participants. He informed that a joint team of officials of WBSETCL, CEA, CTU, PFCCL, POWERGRID(ER-II) visited the Jeerat substation of WBSETCL on 09<sup>th</sup> September, 2016 and had meeting on 10<sup>th</sup> September, 2016 to address the RoW constraint for termination of Jeerat(New)–Jeerat(WBSETCL) 400kV D/c line at Jeerat(WBSETCL). This line is to be implemented through TBCB as part of ERSS-XVIII scheme with PFCCL as BPC. He informed that WBSETCL was requested to submit the detailed survey report regarding feasibility of overhead crossing of existing lines mentioned at 2(i) to 2(iv) by two D/c lines mentioned at 2(v) & 2(vi) for termination at GIS extension of Jeerat S/s of WBSETCL.
2. Following 400kV lines are existing / under construction / planned at 400/220kV substation of Jeerat (WBSETCL) :

**Existing:**

- (i) Jeerat(WBSETCL) – Baharampur/Farakka 400kV S/c line of POWERGRID
- (ii) Jeerat(WBSETCL) – Rajarhat/Subhashgram 400kV S/c line of POWERGRID
- (iii) Jeerat(WBSETCL) – Barkeshwar(WBSETCL) 400kV S/c line of WBSETCL
- (iv) Jeerat(WBSETCL) – Kolaghat(WBSETCL) 400kV S/c line of WBSETCL

**Under Construction:**

- (v) LILO of Sagardighi – Subhashgram 400kV S/c line at Jeerat (WBSETCL) as a part of ERSS-XV – by POWERGRID

**Planned:**

- (vi) Jeerat (New) – Jeerat (WBSETCL) 400kV D/c line (quad) as a part of ERSS-XVIII – to be implemented as ISTS under tariff based competitive bidding route.

The map of the above is at Annexure II & III.

The pointwise discussions held in the meeting are as follows:

3. Detailed survey report submitted by WBSETCL after site visit of Jeerat S/s on 09.09.2016.
  - 3.1 Chief Engineer(PSPA-II) informed that WBSETCL vide its letter dated 05.10.2016 has submitted the detailed survey report for examining the possibility of overhead crossing of existing lines mentioned at 2(i) to 2(iv) by two D/c towers or Multi circuit towers mentioned at 2(v) & 2(vi) for termination at GIS extension of Jeerat S/s of WBSETCL.
  - 3.2 Representative of WBSETCL informed that the overhead crossing of the lines either on Double circuit or Multi circuit towers is not feasible. In both the cases, the height of Double Ckt/Multi ckt towers will be in the range of 75-100 m and conductors after overhead crossing of the lines, need to be brought down at normal gantry height (20-25 m)

within the limited space of 90 meters. This configuration will violate the minimum electrical clearance required and to accommodate the lines, many structures including staff quarters would have to be dismantled at existing Jeerat S/s. He added that in the multi ckt tower, the lower ckt will be used for twin moose conductors and upper ckt will be for quad moose. This configuration will have different tensions on tower at different heights.

- 3.3 Alternatively, WBSETCL proposed that crossing portion of existing lines may be dismantled and the lines may be terminated to the existing AIS bays of Jeerat S/s through GIS bus duct. This arrangement may cost around Rs. 20-30 crores. WBSETCL further recommended that the expenditure for this might be booked in ERSS-XV or ERSS-XVIII i.e. as part of ISTS. This will remove the RoW constraints for the new lines and the two new separate 400kV D/c corridor can be constructed for ERSS-XV and ERSS-XVIII schemes.
- 3.4 On a query regarding demolishing of existing staff quarters to construct the additional towers for terminating the new lines at extended Jeerat S/s (GIS), WBSETCL stated that this option is not agreeable to their management.
4. After detailed discussions, Chief Engineer (PSPA-II), CEA expressed that the suggestion of WBSETCL i.e. dismantling the crossing portion of the existing lines (ISTS and State lines) and termination of the existing lines through GIS bus duct might be the appropriate option, as the new lines mentioned at 2(v) and 2(vi) can be directly terminated on separate double ckt towers at normal height (around 45 meters) to new GIS extension area.

**Members agreed for the above.**

5. Regarding booking of expenditure for above work, mentioned at 4, following was deliberated:
  - (i) **Option-1 (Sharing of cost between POWERGRID and WBSETCL):** It was suggested that the cost of the above arrangement may be shared equally between POWERGRID and WBSETCL as both are having 2 lines each. WBSETCL did not agree to this option. CE (WBSETCL) stated that their DISCOMS may not agree for this, because this rearrangement work is entirely on account of strengthening in the ISTS. As such, this option was dropped.
  - (ii) **Option-2 (Dropping of 400kV Jeerat (New) - Jeerat(WBSETCL) line under TBCB):** POWERGRID stated that the construction of LILO of Sagardighi – Subhashgram 400kV line at Jeerat (WBSETCL) under ERSS-XV does not require any tower crossing as this line could be built along null point between the existing towers. POWERGRID emphasised that the above arrangement is necessary for Jeerat(New) – Jeerat(WBSETCL) 400kV D/c line (quad) being implemented through TBCB.

Upon suggestion of dropping the Jeerat(New) – Jeerat(WBSETCL) 400kV D/c line, CE(WBSETCL) stated that this line is very much necessary for meeting the future load growth at Jeerat and should not be dropped. As such this option was also not considered further.

**(iii) Option-3 (Dismantling of dead end towers and termination through GIS Bus duct by POWERGRID under ISTS) :** Under this option, the additional work as suggested by WBSETCL and mentioned at point 4 above, would be implemented as ISTS and to be included in the scope of ERSS-XV being implemented by POWERGRID. Ownership of these works shall be of POWERGRID as ISTS scope and cost of these reconfiguration (including those for the State lines) to be recovered as tariff by POWERGRID. WBSETCL agreed to this proposal subject to approval of their management.

Thus, out of above options, the Option-3 was agreed. WBSETCL was requested to give their official communication/acceptance from their management on the proposal i.e. dismantling the crossing portion of existing line from (ISTS and State lines) and termination of the existing lines through GIS bus duct by POWERGRID and ownership of same to POWERGRID. (This is similar to LILO of a State transmission line at an ISTS S/s by POWERGRID).

6. POWERGRID clarified that ERSS-XV scheme comprising of LILO of Sagardighi-Subhasgram 400kV S/c line at Jeerat is already under implementation and the above proposed scope of works of dismantling of part of existing lines mentioned at 2 (i) to 2 (iv) and terminating the same through GIS duct to existing Jeerat S/s could be implemented by POWERGRID under ERSS-XV scheme itself.

7. After further discussions, following was agreed:

(i) Following scope may be implemented at Jeerat S/s by POWERGRID as an additional scope under already approved ERSS-XV scheme:

Dismantling of dead end towers and termination of existing lines mentioned at 2 (i) to 2(iv) through GIS duct to the existing 400kV Jeerat AIS S/s (WBSETCL).

(ii) It was also agreed that the termination of the WBSETCL lines mentioned at 2 (iii) & 2(iv) through GIS duct to the existing 400kV Jeerat AIS S/s (WBSETCL) shall be implemented as ISTS and included in the approved scope of ERSS-XV being implemented by POWERGRID and cost recovered by POWERGRID as ISTS transmission tariff .

(iii) Further, it was also acknowledged that implementation of LILO of Sagardighi-Subhasgram 400kV at Jeerat along with associated line bays shall get delayed by about one year due to addition of above mentioned GIS duct arrangement.

(iv) The new lines mentioned at 2(v) and 2(vi) can be directly terminated on separate double ckt towers at normal height (around 45 meters) to new GIS extension area.

## List of the participants of the meeting held on 14.12.2016 at CEA

Sl. No.	Name of the Participant	Designation	Organization
1	Pardeep Jindal	Chief Engineer, (PSPA-II)	CEA
2	Ravinder Gupta	Chief Engineer	CEA
3	Rishika Sharan	Director, (PSPA-II)	CEA
4	U.M.Rao	Deputy Director, (PSPA-II)	CEA
5	R.Nagpal	GM (CMG)	POWERGRID
6	A.P.Gangadharan	AGM (Engg.-S/s)	POWERGRID
7	Ramchandra	DGM (CTU-Plg.)	POWERGRID
8	S.J.Lahiri	DGM (Engg.)	POWERGRID
9	A.Ghosh	CE (CPD)	WBSETCL
10	G.Banerje	ACE (Engg.)	WBSETCL
11	A.Kamasaur	ACE (CPD)	WBSETCL
12	Koushik Bhanmik	SE (Engg.)	WBSETCL

# Farakka - Jeerat 400kV D/c

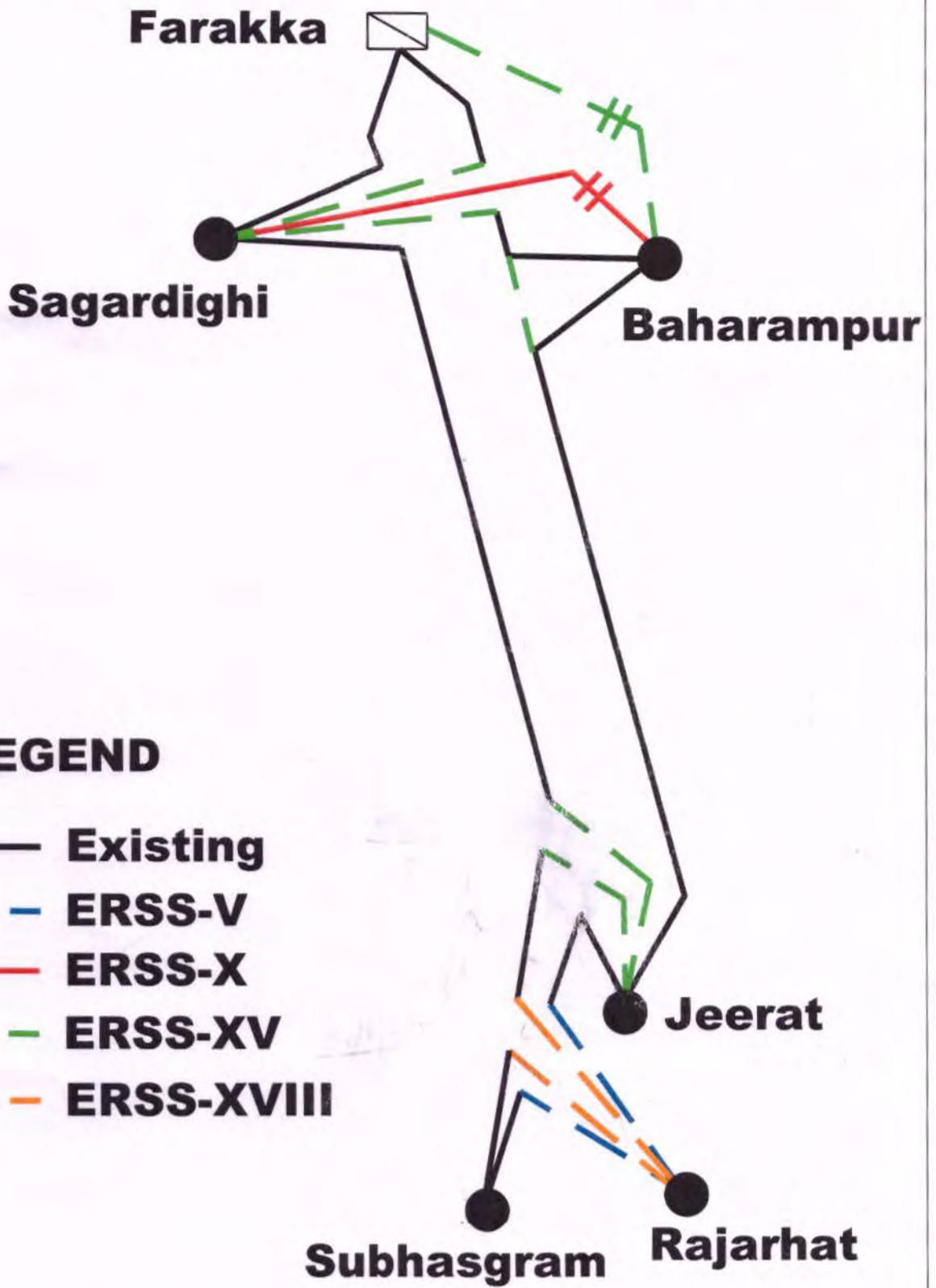

Site: Plan of Proposed 2nos 400KV Tr. Line at Jeerat S/S



General approved design, neither the contractor of his subcontractor is responsible for any defect or damage to the structure or equipment, whether or not caused by fire, lightning, or other causes, arising from the use of the structure and equipment, and the contractor shall be liable for the cost of repair or replacement of the structure and equipment, if any, which shall be applicable nor does it limit the contractor's liability for the cost of repair or replacement of the structure and equipment.

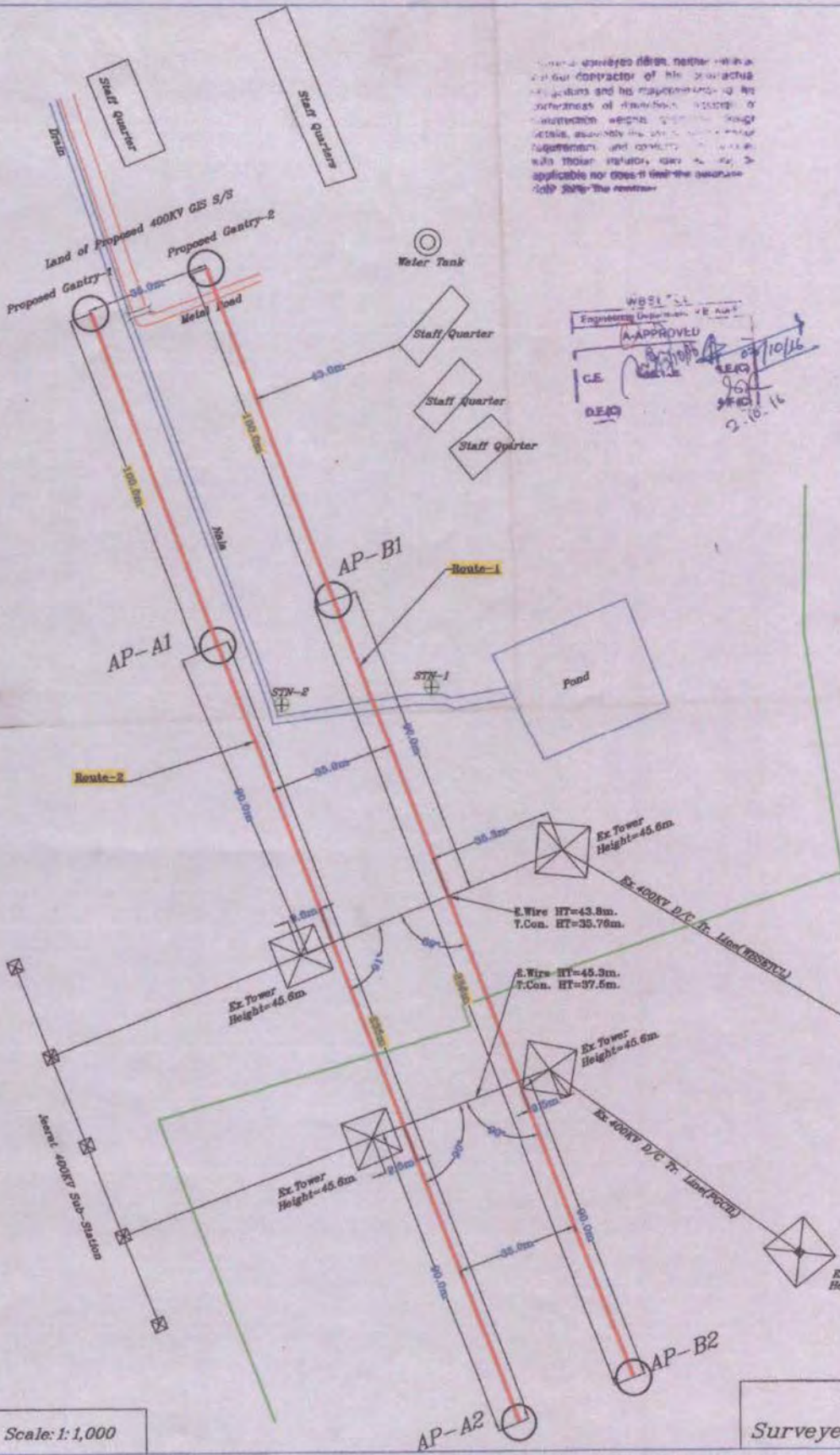

WBSETCL  
Engineering Department  
A-APPROVED  
26/10/16  
2.10.16

Forwards  
26/10/16  
Superintending Engineer (E)  
Kriahnanagar Field Zonal Office  
W.B.S.E.T.C.L.

North Line + Sonbhadra  
26/10/2016

Scale: 1:1,000

Client: WBSETCL  
Surveyed By: North Line

## Annexure-7.1

**I. Latehar 400kV substation (Loads in this area are also supplied by Daltonganj PGCIL 400kV substation)**

Sl. No.	Name of substation	District	Voltage level (kV)	Proposed substation details			Connectivity	Commissioning year
				No of units	Capacity of each unit (MVA)	Total capacity (MVA)		
1	Latehar	Latehar	400/220	2	315	630	400kV D/C line from Latehar 400/220/132kV substation to Patratu 400/220kV substation.	2017-18
							400kV D/C line from Latehar 400/220/132kV substation to Jharkhand pooling station. (By year 2021-22, with commissioning of Essar generation this connectivity will become Essar to Latehar and Essar to Jharkhand pooling station 400kV D/C line)	
			220/132	2	150	300	220kV D/C line from Latehar 400/220/132kV substation to Chatra 220/132kV substation.	
							Charging of 220kV D/C line (presently charged at 132kV) from Daltonganj 132/33kV substation to Latehar 132/33kV substation at 220kV, and termination of the line at PGCIL Daltonganj 400/220/132kV and Latehar 400/220/132kV substation.	
				132kV D/C line from Latehar 400/220/132kV substation to Latehar 132/33kV substation.				
2	Chatra	Chatra	220/132	2	150	300	220kV D/C line from Latehar 400/220kV substation to Chatra 220/132kV substation.	2017-18
							220kV D/C line from Chatra 220/132kV substation to PBCMP (NTPC).	
			132kV D/C line from Chatra 220/132/33kV substation to Chatra (Pratappur) 132/33kV substation.					
			132/33	2	50	100	Charging of under construction 220kV D/C line from Latehar 400/220kV substation to Chatra 220/132kV substation at 132kV level and connecting	2016-17

Sl. No.	Name of substation	District	Voltage level (kV)	Proposed substation details			Connectivity	Commissioning year
				No of units	Capacity of each unit (MVA)	Total capacity (MVA)		
							it to existing Latehar 132/33kV substation.	
3	Lohardagga	Lohardagga	220/132	2	150	300	Charging of 220kV D/C line from Lohardagga 132/33kV substation to Latehar 132/33kV substation at 220kV (previously line was charged at 132kV). Charging of 220kV D/C line from Lohardagga 132/33kV substation to Hatia 220/132kV substation at 220kV (previously line was charged at 132kV).	2018-19
4	Garwha	Garwha	220/132	2	150	300	220kV D/C line from Daltonganj 400/220kV substation to Garwha 220/132kV substation. 132kV D/C line from Garwha 220/132kV substation to Garwha road 132/33kV substation.	2018-19
5	Chatra (Pratappur)	Chatra	132/33	2	50	100	132kV D/C line from Chatra 220/132/33kV substation to Chatra (Pratappur) 132/33kV substation.	2017-18
6	Mahuadanr	Latehar	132/33	2	50	100	132kV D/C line from Latehar 400/220/132kV substation to Mahuadanr 132/33kV substation.	2018-19
7	Chandwa	Latehar	132/33	2	50	100	132kV D/C line from Latehar 400/220/132kV substation to Chandwa 132/33kV substation.	2018-19
8	Chainpur	Gumla	132/33	2	50	100	132kV D/C line from Chainpur 132/33kV substation to Mahuadanr 132/33kV substation. 132kV D/C line from Gumla 132/33kV substation to Chainpur 132/33kV substation.	2020-21
9	Simaria	Chatra	132/33	2	50	100	132kV D/C line from Chatra 220/132/33kV substation to Simaria 132/33kV substation.	2021-22
10	Nagaruntari	Garwha	132/33	2	50	100	132kV D/C line from Garwha 220/132kV substation to	2019-20



Sl. No.	Name of substation	District	Voltage level (kV)	Proposed substation details			Connectivity	Commissioning year
				No of units	Capacity of each unit (MVA)	Total capacity (MVA)		
							Nagaruntari 132/33kV substation.	
11	Meral	Garwha	132/33	2	50	100	132kV D/C line from Garwha 220/132kV substation to Meral 132/33kV substation.	2019-20
12	Ramkanda	Garwha	132/33	2	50	100	132kV D/C line from Garwha 220/132kV substation to Ramakanda 132/33kV substation.	2019-20
13	Panki	Palamu	132/33	2	50	100	132kV D/C line from Chatarpur 132/33kV substation to Panki 132/33kV substation.	2019-20
14	Chatarpur	Palamu	132/33	2	50	100	132kV D/C line from Daltonganj 400/220/132kV substation to Chatarpur 132/33kV substation.	2018-19
							132kV D/C line from Chatarpur 132/33kV substation to Japla 132/33kV substation.	
<b>Additional transmission lines for network strengthening</b>								
1	132kV D/C line from 132/33kV Garwha road substation to Japla 132/33kV substation.							2016-17
2	132kV D/C line from Daltonganj PGCIL 400/220/132kV substation to Daltonganj 132/33kV substation.							2017-18
3	132kV D/C line from Garwha road 132/33kV substation to Daltonganj 132/33kV substation.							2017-18

## II. Patratu 400kV substation

Sl. No.	Name of substation	District	Voltage level (kV)	Proposed substation details			Connectivity	Commissioning year
				No of units	Capacity of each unit (MVA)	Total capacity (MVA)		
1	Patratu	Hazaribagh	400/220	2	315	630	400kV D/C line from Patratu 400/220/132kV substation to Latehar 400/220/132kV substation.	2017-18
							Charging of 400kV S/C (presently charged at 220kV) line from PTPS to TTPS at 400kV and	

							shifting the line from PTPS to Patratu 400/220/132kV substation.	
			220/132 (transformers shifted from PTPS to Patratu)	2	150	300	Shifting of 220kV D/C line from PTPS to Hatia 220/132kV substation to Patratu 400/220/132kV substation.	
							220kV D/C line from Patratu 400/220/132kV substation to PBCMP (NTPC).	
							220kV D/C line from Patratu 400/220/132kV substation to PTPS.	
			132/33	2	50	100	Shifting of 132kV S/C line from PTPS to Patratu (DVC) to Patratu 400/220/132kV substation.	
							Shifting of 132kV S/C line from PTPS to Kanke 132/33kV substation to Patratu 400/220/132kV substation.	
							Shifting of 132kV S/C line from PTPS to Hatia 132/33kV substation to Patratu 400/220/132kV substation.	
2	Barkagaon	Hazaribagh	132/33	2	50	100	132kV D/C line from Patratu 400/220/132kV substation to Barkagaon 132/33kV substation.	2018-19
3	Ramgarh	Hazaribagh	132/33	2	50	100	132kV D/C line from Ramgarh 132/33kV substation to existing Ramgarh (DVC) 132/33kV substation.	2018-19
							132kV D/C line from Chatra 220/132/33kV substation to	

							Ramgarh 132/33kV substation.		
							132kV D/C line from Patratu 400/220/132kV substation to Ramgarh 132/33kV substation.		
							132kV D/C line from Bokaro (Jainamore) 220/132kV substation to Ramgarh 132/33kV substation.		
<b>Additional transmission lines for network strengthening</b>									
1	400kV D/C line from Patratu 400/220/132/33kV substation to Ranchi PGCIL 765/400kV substation.								2018-19

### III. Jasidih 400kV substation

Sl. No.	Name of substation	District	Voltage level (kV)	Proposed substation details			Connectivity	Commissioning year
				No of units	Capacity of each unit (MVA)	Total capacity (MVA)		
1	Jasidih	Deoghar	400/220	2	500	1000	400kV D/C line from Koderma 400/220/132kV substation to Jasidih 400/220/132kV substation.	2018-19
			220/132	2	150	300	220kV D/C line from Dumka 220/132kV substation to Jasidih 220/132/33kV substation.	2017-18
			132/33	2	50	100	132kV D/C line from Jasidih 220/132/33kV substation to Madhupur 132/33kV substation. 132kV D/C line from Deoghar 132/33kV substation to Jasidih 220/132/33kV substation.	
2	Giridih	Giridih	220/132	2	150	300	220kV D/C line from Koderma 400/220/132kV substation to Giridih 220/132/33kV substation. 220kV D/C line from Govindpur 220/132/33kV substation to Giridih 220/132/33kV substation.	2018-19
			132/33	2	50	100	132kV D/C line from Giridih 220/132/33kV substation to Jamua 132/33kV substation.	
3	Godda	Godda	220/132	2	150	300	220kV D/C line from Dumka 220/132 kV substation to Godda 220/132/33kV substation.	2018-19

							220kV D/C line from Godda 220/132/33kV substation to Lalmatia 220/132/33kV substation.	
			132/33	2	50	100	132kV D/C line from Godda 220/132/33kV substation to Amarpura 132/33kV substation.	
							LILO of one circuit of 132kV D/C line from Dumka 132/33kV substation to Lalmatiya 220/132/33kV substation at Godda 220/132/33kV substation.	
4	Jamua	Giridih	132/33	2	50	100	132kV D/C line from Giridih 220/132/33kV substation to Jamua 132/33kV substation.	2018-19
5	Saria	Giridih	132/33	2	50	100	132kV D/C line from Bishnugarh 132/33kV substation to Saria 132/33kV substation.	2018-19
6	Chitra	Deoghar	132/33	1	50	70	LILO of 132kV S/C line from Deoghar 132/33kV substation to Jamtara 132/33kV substation at Chitra 132/33kV substation.	2016-17
				1	20			
7	Jarmundi	Dumka	132/33	2	50	100	LILO of 132 kV D/C line from Dumka 132/33kV substation to Deoghar 132/33kV substation at Jarmundi 132/33kV substation.	2018-19
8	Sikaripara	Dumka	132/33	2	50	100	132kV D/C line from Dumka 132/33kV substation to Sikaripara 132/33kV substation.	2018-19
9	Hansdiha	Dumka	132/33	2	50	100	LILO of one circuit of 132 kV D/C line from Lalmatiya 220/132/33kV substation to Dumka 132/33kV substation at Hansdiha 132/33kV substation.	2018-19
							132kV D/C line from Hansdiha 132/33kV substation to Banka (PGCIL) substation.	
10	Amarpara	Pakur	132/33	2	50	100	132kV D/C line from Godda 220/132/33kV substation Amarpura 132/33kV substation.	2018-19
							132kV D/C line from Pakur 132/33kV substation to Amarpura 132/33kV substation.	
							132kV D/C line from Dumka 132/33kV to Amarpura 132/33kV substation.	
11	Rajmahal	Sahebganj	132/33	2	50	100	132kV D/C line from Sahebganj 132/33kV substation to Rajmahal 132/33kV substation.	2018-19
12	Udhwa	Sahebganj	132/33	2	50	100	132kV D/C line from Sahebganj 132/33kV substation to Udhwa 132/33kV substation.	2018-19
<b>Additional transmission lines for network strengthening</b>								

1	400kV D/C line from PGCIL Dhanbad 400/220kV substation to Jasidih 400/220/132/33kV substation.	2019-20
2	Conversion of 220kV S/C line from Lalmatia 220/132/33kV substation to Farakka NTPC generation into D/C line.	2020-21
3	220kV D/C line from Giridih 220/132/33kV substation to Jasidih 400/220kV substation.	2021-22
4	132kV D/C line from 220/132kV Dumka substation to Jamtara 132/33kV substation.	2018-19
5	132kV D/C line from Sahebganj 132/33kV substation to Pakur 132/33kV substation.	2018-19
6	132kV D/C line from Saria 132/33kV substation to Giridih 220/132/33kV substation.	2021-22

#### IV. Chandil 400kV substation (Loads in this are also supplied by Ramchandrapur and Chaibasa PGCIL 400kV substations)

Sl. No.	Name of substation	District	Voltage level (kV)	Proposed substation details			Connectivity	Commissioning year
				No of units	Capacity of each unit (MVA)	Total capacity (MVA)		
1	Chandil	Saraikela	400/220	2	500	1000	400kV D/C line from PGCIL Chaibasa 400/220/132kV substation to Chandil 400/220/132kV substation.	2018-19
							LILO of 220kV D/C line from Ranchi PGCIL 400/220kV substation to Chandil 220/132kV substation at Chandil 400/220kV substation.	
2	Tamar	Ranchi	220/132	2	150	300	LILO of 220kV D/C line from Ranchi PGCIL 400/220kV substation to Chandil 220/132kV substation at Tamar 220/132kV substation.	2018-19
3	Simdega	Simdega	220/132	2	150	300	220kV D/C line from Bero 220/132/33kV substation to Simdega 220/132kV substation.	2021-22
							132kV D/C line from Simdega 220/132kV substation to Kolebira 132/33kV substation.	
			LILO of 132kV D/C line from Simdega 132/33kV substation to Kurdeg 132/33kV substation at Simdega 220/132kV substation.					
			132/33	2	50	100	132kV D/C line from Manoharpur 132/33kV substation to Simdega 132/33kV substation.	2016-17
							132kV D/C line from Gumla 132/33kV substation to Simdega 132/33kV substation.	

Sl. No.	Name of substation	District	Voltage level (kV)	Proposed substation details			Connectivity	Commissioning year
				No of units	Capacity of each unit (MVA)	Total capacity (MVA)		
4	Jadugoda	East Singhbhum	220/132	2	150	300	LILO of proposed 220kV D/C line from Ramchandrapur 220/132/33kV substation to Chaibasa 220/132kV substation at Jadugoda 220/132/33kV substation.(Interim arrangement)	2018-19
							220kV D/C line from Adityapur 220/132kV substation to Jadugoda 220/132/33kV substation.(With commissioning of Adityapur 220/132/33kV substation)	
5	Adityapur	East Singhbhum	220/132	2	150	300	LILO of 220kV D/C line from Ramchandrapur PGCIL 400/220kV substation to Chaibasa 220/132kV substation at Adityapur 220/132kV substation.	2021-22
							220kV D/C line from Adityapur 220/132kV substation to Jadugoda 220/132/33kV substation.(With commissioning of Adityapur 220/132/33kV substation)	
							LILO of 132kV S/C line from Chandil 220/132kV substation to Adityapur 132/33kV substation at Adityapur 220/132kV substation.	
							LILO of 132kV S/C line from Rajkharsawan 132/33kV substation to Adityapur 132/33kV substation at Adityapur 220/132kV substation.	
6	Chouka	Saraikela	132/33	2	50	100	132kV D/C line from Tamar 220/132/33kV substation to silli 132/33kV substation via Chouka 132/33kV substation.	2018-19
7	Chakuliya	East Singhbhum	132/33	2	50	100	132kV D/C line from Chandil 220/132kV substation to Chakuliya 132/33kV substation.	2018-19
							132kV D/C line from Bahragora 132/33kV substation to Chakuliya 132/33kV substation.	
							132kV D/C line from Dalbhumgarh 132/33kV substation to Chakuliya 132/33kV substation.	

Sl. No.	Name of substation	District	Voltage level (kV)	Proposed substation details			Connectivity	Commissioning year
				No of units	Capacity of each unit (MVA)	Total capacity (MVA)		
8	Bahragora	East Singbhum	132/33	2	50	100	132kV D/C line from Dalbhumgarh 132/33kV substation to Bahragora 132/33kV substation.	2018-19
							132kV D/C line from Bahragora 132/33kV substation to Chakuliya 132/33kV substation.	
9	Kandra	Saraikela	132/33	2	50	100	LILO of one circuit of 132kV D/C line from Chandil 220/132kV substation to Rajkharsawan 132/33kV substation at Kandra 132/33kV substation.	2018-19
10	Mango	East Singbhum	132/33	2	50	100	132kV D/C line from Ramchandrapur 220/132kV substation to Mango 132/33kV substation.	2018-19
							LILO of one circuit of 132kV D/C line from Chandil 220/132kV substation to Golmuri 132/33kV substation at Mango 132/33kV substation.	
11	Sundernagar	East Singbhum	132/33	2	50	100	132kV D/C line from Jadugoda 132/33kV substation to Sundernagar 132/33kV substation.	2018-19
12	Manoharpur	West Singbhum	132/33	2	50	100	LILO of 132kV S/C line from Goelkera 132/33kV substation to Tarkera 220/132kV substation at Manoharpur 132/33kV substation (commissioned).	2016-17
							132 KV D/C line from Chaibasa 220/132/33kV substation to Manoharpur 132/33kV substation.	
13	Ramchandrapur	East Singbhum	132/33	2	50	100	Addition of 132/33kV transformers at existing Ramchandrapur 220/132kV substation.	2016-17
14	Kolebira	Simdega	132/33	2	50	100	132kV D/C line from Kamdara 132/33kV substation to Kolebira 132/33kV substation.	2018-19
15	Kurdeg	Simdega	132/33	2	50	100	132kV D/C line from Simdega 132/33kV substation to Kurdeg 132/33kV substation.	2018-19
<b>Additional transmission lines for network strengthening</b>								
1	400kV D/C line from PGCIL Dhanbad 400/220kV substation to Chandil 400/220kV substation.							2019-20

Sl. No.	Name of substation	District	Voltage level (kV)	Proposed substation details			Connectivity	Commissioning year
				No of units	Capacity of each unit (MVA)	Total capacity (MVA)		
2	220kV D/C line from 220/132kV Ramchandrapura substation to Chaibasa 220/132/33kV substation.							2016-17
3	220kV D/C line from Chaibasa 220/132/33kV substation to Gua SAIL.							2018-19
4	132kV D/C line from 220/132 kV Ramchandrapur substation to Jadugoda 132/33kV substation.							2016-17
5	132kV D/C line from 132/33kV Jadugoda substation to Dalbhumgarh 132/33kV substation.							2016-17
6	132kV D/C line from 132/33kV Chakradharpur substation to Chaibasa 220/132/33kV substation.							2018-19
7	132kV D/C line from Noamundi 132/33kV substation to Chaibasa 220/132/33kV substation.							2018-19
8	LILO of one Ckt of 132 KV D/C line from Noamundi 132/33kV substation to Chaibasa 220/132/33kV substation at Kendposi 132/33kV substation.							2018-19
9	132kV D/C line from 220/132/33kV Chaibasa substation to Rajkharsawan 132/33kV substation.							2018-19
10	LILO of one circuit of 132kV D/C line from Chaibasa 220/132/33kV substation to Manoharpur 132/33kV substation at Goelkera 132/33kV substation.							2018-19
11	132kV D/C line from Noamundi 132/33kV substation to Manoharpur 132/33kV substation.							2020-21

## V. Koderma 400kV substation

Sl. No.	Name of substation	District	Voltage level (kV)	Proposed substation details			Connectivity	Commissioning year
				No of units	Capacity of each unit (MVA)	Total capacity (MVA)		
1	Koderma	Koderma	400/220	2	500	1000	400kV D/C line from Koderma 400/220/132kV substation to Koderma (DVC) 400/220kV substation.	2018-19
							400kV D/C line from Koderma 400/220/132kV substation to Jasidih 400/220/132kV substation.	
							LILO of 400kV S/C line from TTPS to Biharsharif at Koderma 400/220/132kV substation.	
			220/132	2	150	300	220kV D/C line from Koderma 400/220/132kV substation to Giridih 220/132/33kV substation.	
			132/33	2	50	100	-	
2	Domchanch	Giridih	220/132	2	150	300	220kV D/C line from Koderma 400/220/132kV substation to Domchanch 132/33kV substation.	2021-22
			132/33	2	50	100	-	



Sl. No.	Name of substation	District	Voltage level (kV)	Proposed substation details			Connectivity	Commissioning year
				No of units	Capacity of each unit (MVA)	Total capacity (MVA)		
3	Barkatha	Koderma	220/132	2	150	300	220kV D/C line from Hazaribagh 220/132/33kV substation to Barkatha 220/132/33kV substation.	2021-22
			132/33	2	50	100	-	
4	Hazaribagh	Hazaribagh	220/132	2	150	300	220kV D/C line from Tenughat TPS to Hazaribagh 220/132/33kV substation.	2018-19
			132/33	2	50	100	220kV D/C line from Hazaribagh 220/132/33kV substation to Hazaribagh (DVC) 220/132kV substation. 132kV D/C line from Hazaribagh 220/132/33kV substation to Bishnugarh 132/33kV substation.	
5	Barhi	Hazaribagh	132/33	2	50	100	132kV D/C line from Chatra 220/132/33kV substation to Barhi 132/33kV substation.	2018-19
<b>Additional transmission lines for network strengthening</b>								
1	132kV D/C line from Barhi 132/33kV substation to Hazaribagh (JSEB) 220/132/33kV substation.						2021-22	

**VI. Mandar 400kV substation (Loads in this area are also supplied by Ranchi PGCIL 400kV substation)**

Sl. No.	Name of substation	District	Voltage level (kV)	Proposed substation details			Connectivity	Commissioning year
				No of units	Capacity of each unit (MVA)	Total capacity (MVA)		
1	Mandar	Ranchi	400/220	2	500	1000	LILO of 400kV D/C line from Ranchi PGCIL 765/400kV substation to Patratu 400/220/132/33kV substation at Mandar 400/220kV substation.	2021-22
							220kV D/C line from Ratu 220/132/33kV substation to Mandar 400/220kV substation.	
							220kV D/C line from Tamar 220/132/33kV substation to Mandar 400/220kV substation via Khunti 220/132/33kV substation.	

Sl. No.	Name of substation	District	Voltage level (kV)	Proposed substation details			Connectivity	Commiss ioning year
				No of units	Capacity of each unit (MVA)	Total capacity (MVA)		
							LILO of 220kV D/C line from Hatia 220/132kV substation to Lohardagga 220/132kV substation at Mandar 400/220kV substation.	
							220kV D/C line from Mandar 400/220kV substation to Bero 220/132/33kV substation.	
2	Ratu	Ranchi	220/132	2	150	300	220kV D/C line from Patratu 400/220kV substation to Ratu 220/132kV substation.	2018-19
			132/33	2	50	100	132kV D/C line from Hatia 220/132kV substation to Ratu 220/132kV substation.	
3	Bero	Ranchi	220/132	2	150	300	220kV D/C line from Mandar 400/220kV substation to Bero 220/132/33kV substation.	2021-22
							220kV D/C line from Khunti 220/132/33kV substation to Bero 220/132/33kV substation.	
			132/33	2	50	100	132kV D/C line from Bero 220/132/33kV substation to Kamdara 132/33kV substation.	
4	Khunti	Khunti	220/132	2	150	300	220kV D/C line from Tamar 220/132/33kV substation to Khunti 220/132kV substation.	2021-22
							220kV D/C line from Khunti 220/132/33kV substation to Bero 220/132/33kV substation.	
			132/33	2	50	100	132kV D/C line from Tamar 220/132/33kV substation to Khunti 132/33kV substation.	2017-18
						LILO of 132kV S/C line form Hatia 132/33kV substation to Kamdara 132/33kV substation at Khunti 132/33kV substation.		

Sl. No.	Name of substation	District	Voltage level (kV)	Proposed substation details			Connectivity	Commissioning year
				No of units	Capacity of each unit (MVA)	Total capacity (MVA)		
5	Sarwal	Ranchi	220/132	2	150	300	LILO of 220kV D/C line from Ranchi PGCIL 400/220kV substation to Chandil 220/132kV substation at Sarwal 220/132/33kV substation.	2020-21
			132/33	2	50	100	-	
6	Irba	Ranchi	132/33	2	50	100	132kV D/C line from Irba 132/33kV substation to Kanke 132/33kV substation.	2018-19
7	Gola	Hazaribagh	132/33	2	50	100	132kV D/C line from Gola 132/33kV substation to Silli 132/33kV substation.	2018-19
8	Angada	Ranchi	132/33	2	50	100	132kV D/C line from Sikkidri 132/33kV substation to Angada 132/33kV substation.	2018-19
							132kV D/C line from Angada 132/33kV substation to Silli 132/33kV substation.	
9	Silli	Ranchi	132/33	2	50	100	132kV D/C line from Silli 132/33kV substation to Angada 132/33kV substation.	2018-19
							132kV D/C line from Silli 132/33kV substation to Gola 132/33kV substation.	
							132kV D/C line from Chouka 132/33kV substation to silli 132/33kV substation.	
							132kV D/C line from Silli 132/33kV substation to Sikkidri 132/33kV substation.	
<b>Additional transmission lines for network strengthening</b>								
1	220kV D/C line from 220/132kV Hatia substation to Ranchi (PGCIL) 400/220kV substation.						2016-17	
2	132kV D/C line from 132/33kV Kanke substation to Hatia 220/132kV substation.						2016-17	
3	LILO of 132kV S/C (3rd ckt) from Hatia 132/33kV substation to Sikkidri 132/33kV substation at Namkum 132/33kV substation.						2016-17	
4	Re-conductoring of Hatia-Namkum-Sikkidri 132kV D/C line with HTLS conductor.						2016-17	
5	Re-conductoring of Hatia-Kamdara 132kV S/C line with HTLS conductor.						2016-17	
6	132kV D/C line from Irba 132/33kV substation to Ramgarh 132/33kV substation.						2019-20	

Sl. No.	Name of substation	District	Voltage level (kV)	Proposed substation details			Connectivity	Commissioning year
				No of units	Capacity of each unit (MVA)	Total capacity (MVA)		
7	132kV D/C line from Irba 132/33kV substation to Ratu 220/132/33kV substation.						2019-20	

**Govindpur 220kV substation (Dhanbad PGCIL 400kV substation is a power source in this area)**

Sl. No.	Name of substation	District	Voltage level (kV)	Proposed substation details			Connectivity	Commissioning year
				No of units	Capacity of each unit (MVA)	Total capacity (MVA)		
1	Govindpur	Dhanbad	220/132	2	150	300	220 kV D/C line from TTPS to Govindpur 220/132/33kV substation.	2016-17
							220kV D/C line from Dumka 220/132kV substation to Govindpur 220/132/33kV substation.	
			132/33	2	50	100	-	
2	Bokaro (Jainamore)	Bokaro	220/132	2	150	300	LILO of 220kV D/C line from TTPS to Govindpur 220/132/33kV substation at Bokaro 220/132/33kV substation	2017-18
			132/33	2	50	100	-	
3	Gomia	Giridih	220/132	2	150	300	220kV D/C line from Tenughat TPS to Gomia 220/132/33kV substation.	2018-19
			132/33	2	50	100	132kV D/C line from Gomia 220/132/33kV substation to Dugda 132/33kV substation.	
4	Chandrapura	Bokaro	220/132	2	150	300	220kV D/C line from Tenughat TPS to Chandrapura 220/132/33kV substation.	2020-21
			132/33	2	50	100	132kV D/C line from Chandrapura 220/132/33kV substation to Dugda 132/33kV substation.	
5	Baliyapur	Dhanbad	220/132	2	150	300	220kV D/C line from Govindpur 220/132/33kV substation to Baliyapur 220/132/33kV substation.	2020-21

Sl. No.	Name of substation	District	Voltage level (kV)	Proposed substation details			Connectivity	Commissioning year
				No of units	Capacity of each unit (MVA)	Total capacity (MVA)		
			132/33	2	50	100	LILO of 132kV D/C line from Putki 132/33kV substation to Pathardih 132/33kV substation at Baliyapur 220/132/33kV substation.	
6	Topchanchi	Giridih	220/132	2	150	300	220kV D/C line from Govindpur 220/132/33kV substation to Topchanchi 220/132/33kV substation.	2020-21
			132/33	2	50	100	132kV D/C line from Topchanchi 220/132/33kV substation to Dugda 132/33kV substation.	
7	Palojori	Deoghar	220/132	2	150	300	LILO of 220kV D/C line from Dumka 220/132/33kV substation to Govindpur 220/132/33kV substation at Palojori 220/132/33kV substation.	2021-22
			132/33	2	50	100	-	
8	Petarwar	Bokaro	132/33	2	50	100	132kV D/C line from Bokaro (Jainamore) 220/132/33kV substation to Petarwar 132/33kV substation.	2018-19
9	Dugda	Bokaro	132/33	2	50	100	132kV D/C line from Bokaro (Jainamore) 220/132/33kV substation to Dugda 132/33kV substation.	2018-19
							132kV D/C line from Gomia 220/132/33kV substation to Dugda 132/33kV substation.	
10	Putki	Dhanbad	132/33	2	50	100	132kV D/C line from Govindpur 220/132/33kV substation to Putki 132/33kV substation.	2018-19
							132kV D/C line from Putki 132/33kV substation to Pathardih 132/33kV substation.	
							132kV D/C line from Putki 132/33kV substation to Mahuda 132/33kV substation.	
11	Pathardih	Dhanbad	132/33	2	50	100	132kV D/C line from Putki 132/33kV substation to Pathardih 132/33kV substation.	2018-19

Sl. No.	Name of substation	District	Voltage level (kV)	Proposed substation details			Connectivity	Commissioning year
				No of units	Capacity of each unit (MVA)	Total capacity (MVA)		
12	Chandankiyari	Bokaro	132/33	2	50	100	132kV D/C line from Govindpur 220/132/33kV substation to Chandankiyari 132/33kV substation.	2018-19
							132kV D/C line from Bokaro (Jainamore) 220/132/33kV substation to Chandankiyari 132/33kV substation.	
13	Mahuda	Dhanbad	132/33	2	50	100	132kV D/C line from Putki 132/33kV substation to Mahuda 132/33kV substation.	2018-19
14	Bishnugarh (Banaso)	Hazaribagh	132/33	2	50	100	132kV D/C line from Hazaribagh 220/132/33kV substation to Bishnugarh 132/33kV substation.	2018-19
							132kV D/C line from Saria 132/33kV substation to Bishnugarh 132/33kV substation.	
							132kV D/C line from Gomia 220/132/33kV substation to Bishnugarh 132/33kV substation.	
15	Nirsa	Dhanbad	132/33	2	50	100	132kV D/C line from Baliyapur 220/132/33kV substation to Nirsa 132/33kV substation.	2021-22
<b>Additional transmission lines for network strengthening</b>								
1	220kV D/C line from Dhanbad PGCIL to Govindpur 220/132/33kV substation.							2019-20
2	220kV D/C line from Dhanbad PGCIL to Bokaro (Jainamore) 220/132/33kV substation.							2019-20
3	132kV D/C line from Govindpur 220/132/33kV substation to Madhupur 132/33kV substation.							2021-22



भारत सरकार  
Government of India  
विद्युत मंत्रालय  
Ministry of Power  
केंद्रीय विद्युत प्राधिकरण  
Central Electricity Authority  
विद्युत प्रणाली योजना एवं मूल्यांकन प्रभाग-II  
Power System Planning & Appraisal Division-II

No: 200/16/PSPA-II/2017/ 373-381

Dated: 11.05.2017

To

As per address list

**Subject:** Minutes of the meeting related to Connectivity of Railway TSSs with ISTS network in Mughalsarai-Howrah Railway Route.

Sir,

The minutes of the meeting held on 20.04.2017 at CEA, Sewa Bhawan, R K Puram, New Delhi regarding above subject is enclosed.

Yours faithfully,

(Pardeep Jindal)  
11/5/2017

Chief Engineer (PSPA-II)

**List of addressee:**

1. Executive Director(EEM), Railway Board, Room No. 102-A, Rail Bhawan, New Delhi- 110001	2. General Manager, Railway Energy Management Co. Ltd.( REMCL) Ground floor, Central wing, Plot No-1, Sector 29, Gurgaon-122001
3. COO (CTU), PGCIL, Saudamini, Plot No. 2, Sector-29, Gurgaon-122001. Fax No. 0124-2571760/62)	4. CEO, POSOCO B-9, Qutub Institutional Area, Katwaria Sarai, New Delhi-110016
5. Executive Director (System), Damodar Valley Corporation DVC Towers, VIP Road, Kolkata-700054. Tel. 033-23557939 Fax No. 033-23554841	6. Managing Director, Bihar State Power Transmission Company, Vidyut Bhavan, Baily Road, Patna- 800021. Tel. 0612-2504442 Fax No. 0612-2504557
7. Managing Director, Jharkhand Urja Sancharan Nigam Limited Engineering Building, H.E.C., Dhurwa, Ranchi-834004. Fax-0651-2400799	8. Director (System Operation), West Bengal State Electricity Transmission Company Ltd, Vidyut Bhavan, 5th Floor, Block-D, Bidhannagar, Sector-II, Kolkata-700091. Fax No.033-23342243
9. Managing Director, Uttar Pradesh Power Corporation Limited ( UPPCL), Shakti Bhavan, Ashok Marg, Lucknow, Uttar Pradesh	



**Minutes of the meeting related to Connectivity of Railway TSSs with ISTS network in  
Mughalsarai-Howrah Railway Route, held on 20.04.2017 at CEA.**

List of participants is enclosed at Annexure-1.

Member (Power System), CEA welcomed the participants and stated that in an earlier meeting held in CEA on 07.10.2016, in regard to connectivity of Railways with ISTS network for the Mughalsarai - Howrah and the Delhi - Bharuch routes, it was decided that the issue of disconnection or paralleling of Railway TSS with STU network, would be further studied. To discuss the matter, the meeting was being held.

The following were discussed in the meeting:

1. CE (PSPA-II), CEA informed that Railways has proposed to connect their Traction Sub-stations (TSS) with ISTS points in Mughalsarai-Howrah route. The identified ISTS substations are Patna, Gaya, Maithon, Durgapur, Lakhisarai and Subhashgram. He expressed that simultaneously paralleling of Railway TSS with STU and ISTS network may increase the fault level and would result in stranded infrastructure. He stated that, at present, Railways are getting supply from STU network on this route. He asked Railways about the necessity of another infrastructure for Railways, when they are able to draw power from STU network in a reliable manner.
2. Director (Railways) informed that the decision of Railways to get connected to ISTS network and disconnection from STU network is purely based on economics of getting cheaper power from other sources through ISTS network. He, however, confirmed that they are getting reliable power from STU network. He further informed that the infrastructure for Railways connectivity to STU network was funded by Railways and built by respective STUs as a deposit work for Railways. As per the contract agreement with STUs, the assets are maintained by STUs.
3. Member (Power System), CEA requested Railways to share the economic analysis of shifting of Railway load from STUs/DVC to ISTS in this route. Director (Railways) said that he would send the report immediately.
4. D.C.E (DVC) stated that Railways connectivity to DVC network (from generator point upto 25 kV system) was created and funded by DVC and not by Railways. At present total Railway load of DVC is about 320MW, which they supply to Railway, at an average cost of Rs.4.80/ unit. Which is quite competitive price considering the higher reliability of power supply from two sources specially for Railways. He also stated that DVC has already tied up for generation projects and made investment in transmission considering recent specific request from the Railways. Hence, proposal of Railways to disconnection from DVC would result these infrastructure, as redundant

and investment as non-performing asset for DVC. Before agreeing to Railways proposal based on their economic consideration, economic aspects of DVC/STUs should also be considered.

5. Director (Railways) agreed with the DVC statement and stated that considering above facts, the case of DVC would be resolved mutually. However, he further added that the scheme for disconnection in Mughalsarai-Howrah route have been planned in a holistic way and as per plan, Railway would be disconnected from DVC also on this route. He said that these disconnections would be carried out in accordance with the agreements between Railways and the STUs/DVC. He indicated that Railways can disconnect from STU/DVC, giving legal notice as per these agreements.
6. Chief Engineer (PSPA-II), CEA stated that Railways may intimate the STUs and DVC regarding the date from which Railways would likely to disconnect, so that they plan for utilization of those network for other purposes, if possible. Representative of Railways replied that the disconnection may takes place in around (3-5) years time. Railways said that they can send advance intimation to STUs for disconnection, once the scheme of connection with ISTS gets agreed in the Standing Committee of CEA.
7. Director(BSPTCL) stated that Railways connectivity network with STU were built as deposit work by STU for Railways, however as per the legal agreement, the infrastructure belongs to the STU. He added that the load of Railways TSS would be around 80 to 100 MW at each 220 kV point and this would lead to under-utilisation of bays/lines/space at each ISTS points and thus is not an optimal planning as per the Electricity Act. He added that space for 2 No. 220kV Bays at ISTS S/s have been kept for future expansion of states and in this case the user would be only the Railways and thus no space would be left for STUs to meet their future requirement.. He also informed that there is no space at Patna and Gaya ISTS S/s for Railways connectivity.
8. Chief Engineer (UPPTCL) stated that the infrastructure for Railways was created considering Railways as important customer in UP. Now after disconnections, bays etc would have to be utilised for other purposes. In future, if railways again requires connectivity from STUs, this would not again be allotted to them.
9. AGM (POSOCO) expressed that for reliable supply to Railways, the STU and ISTS network may be kept in parallel. This would be, as per CEA's Planning Criteria of Power System Planning for important loads. Chief Engineer (PSPA-I), CEA stated that generally connectivity from two points i.e both STU and ISTS are not recommended. Two connectivity's for Railways, however can be considered either from STU or ISTS. GM(REMCL) Railways stated that they have planned their connectivity to TSS from two ISTS supply points and shared their scheme (a copy of which is given at Annex-II)

10. Director (BSPTCL) stated that Railways load at Bihar would be around 200MW. Recently, Bihar have allowed open access for 50MW to Railways and the remaining may be granted gradually. He stated that state network would become stranded after building Railway network with ISTS. This would be national wastage of resources and Public money. He added that Railways may be advised to again look into the economics of connectivity to ISTS points, as many of the states have already granted/ are in the process of granting NOC for open access and as such there is no justification for getting connected with ISTS.
11. Regarding control area for scheduling, metering and deviation, AGM(POSOCO) informed that as per CERC order, there would be two control areas, in each state i.e. one for RLDC and the other for SLDC( if they have connections from STUs also) for above purposes.
12. It is noted that no representative from West Bengal and Jharkhand was present in the meeting.
13. On the basis of above following was concluded.
- i. Railways has to share the economic analysis of shifting of Railway load from STUs/DVC to ISTS in this route, which is basis of their proposal. Representative of Railways intimated that they would soon send the report.
  - ii. As the transmission system is planned in an integrated manner, Railways were advised to again look into the economics of connectivity to ISTS points, as many of the states have already granted /are in the process of granting NOC for open access.
  - iii. Transmission system for delivery of power to Railways need to be planned in according with the Electricity Act 2003 and thus taken up for discussion with Standing Committee constituted by CEA.
  - iv. No representative from West Bengal and Jharkhand was present in the meeting. Meeting ended with vote of thanks to the Chair.
-

**Annexure-I****List of the participants of the meeting held on 20.04.2017 at CEA**

<b>Sl. No.</b>	<b>Name of the Participant</b>	<b>Designation</b>	<b>Organization</b>
1	K.K.Arya ( <b>In chair</b> )	Member( Power System)	CEA
2	Pardeep Jindal	Chief Engineer, (PSPA-II)	CEA
3	Rishika Sharan	Director, (PSPA-II)	CEA
4	U.M.Rao	Dy. Director, (PSPA-II)	CEA
5	S.A.Verma	Asst. Director-I	CEA
6	Punit Agrawal	Director(Power Supply)	Ministry of Railways
7	J.C.S.Bora	G.M.	REMCL
9	Bhaskar Sharma	Director( Project)	BSPTCL
10	Suman Guchh	C.E.(Transmission)	UPPTCL
11	Subir Bhada	D.C.E (E)	DVC
12	Sangita Sil	S.E.(E)	DVC
13	S.S.Barpanda	AGM, NLDC	POSOCO
14	Ram Chandra	DGM(CTU-Plg)	POWERGRID

**Annexure-II**

Page 1

**Summary of proposed transmission scheme is as under:**

- Supply from the PGCIL substation shall be taken at 220 kV (or at 132 kV if available) through 2 no. bays.
- Supply from PGCIL substation shall be taken to 220/132 kV substation (to be constructed) through D/C lines. Land of size about 240x60 m shall be required for the 220/132 kV substation.
- From 220/132 kV substation, 132 kV supply shall be extended to up as well as down directions of the Railway line through D/C lines.
- On one direction 132 kV line shall feed about 3 TSS. Loop in Loop out arrangement shall be made at the existing TSS for extending supply to next TSS. Alternatively (in case of ROW problem near existing TSS) 2- $\Phi$ , 132 kV Supply from the above 3- $\Phi$ , 132 kV line shall be extended to the TSS from a Tee-off point to be constructed at open space near the TSS.
- One 220/132 kV substation and group of TSSs supplied through it shall be controlled through SCADA centre at the 220/132 kV substation.
- Group of two TSSs shall be protected by a common numerical distance protection relays to be provided at the 220/132 kV substation or at the selective TSS.
- Two Hot line communication channels shall be made available between each of the 220/132 kV substation and the TSS in that element and nodal Traction power control (TPC) of the element. Two Hot line links shall also be made available between two adjacent 220/132 kV substations and respective ISTS point.

**PROPOSED SCHEME OF CONNECTIVITY OF TSS WITH ISTS POINT**

**Note: LILO can be within the TSS or out of TSS based on Land and ROW availability.**

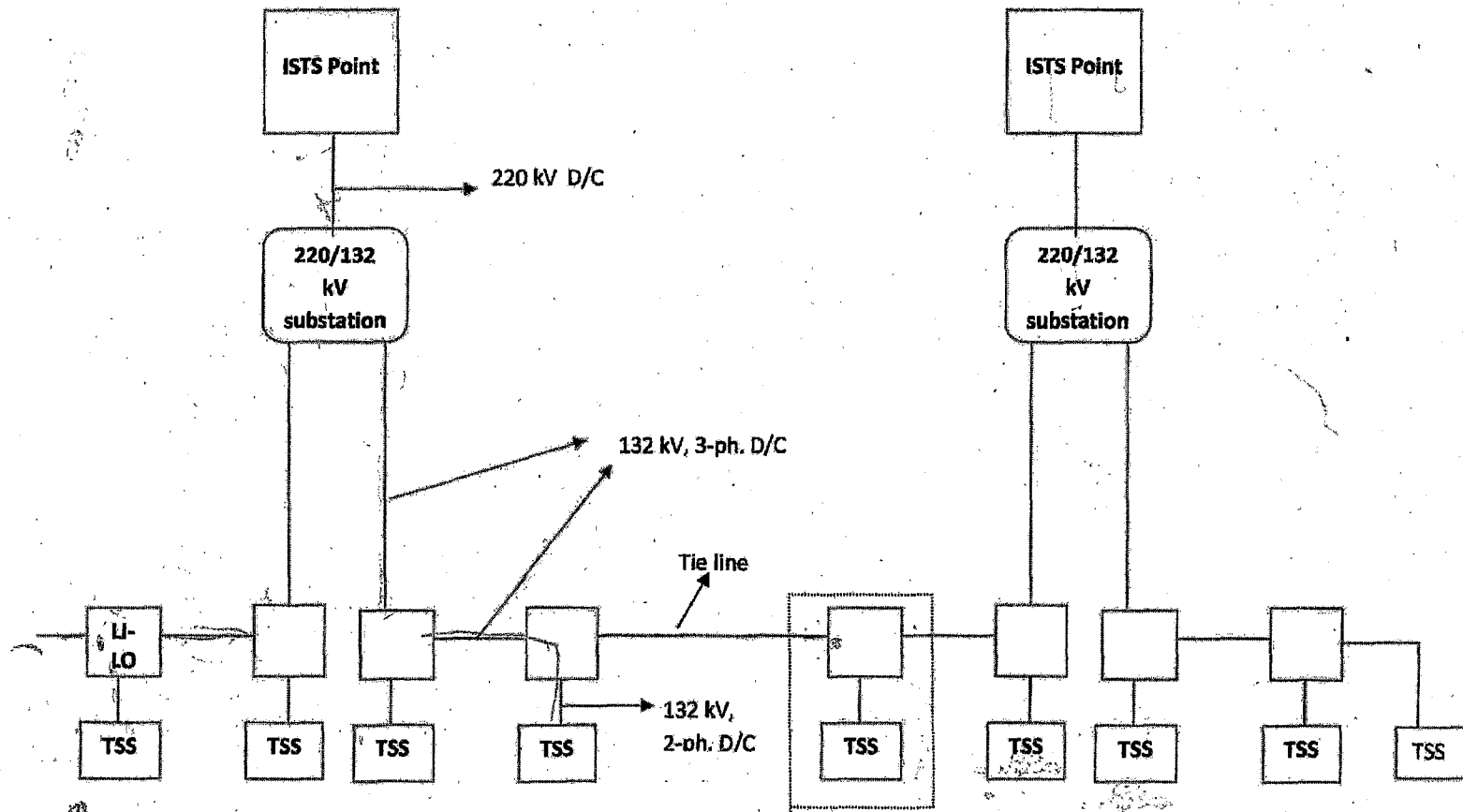

S.No. 741

**Scope of Works for the scheme  
“Interconnection of Northern part of Bangladesh with Indian Grid”**

**1.0 Indian Side****1.1 Transmission Lines**

- (a) Katihar (ER) – Parbotipur (Bangladesh) 765kV D/c line (to be initially operated at 400kV) – Indian Portion only
- (b) LILO of both ckts of New Purnea - Rajarhat 400kV D/c (triple snowbird) line (one ckt via Gokarna and other ckt via Farakka) at Katihar
- (c) Parbotipur (Bangladesh) - Bornagar (NER) 765kV D/c line (to be initially operated at 400kV) – Indian Portion only
- (d) LILO of both circuits of Balipara – Bongaigaon 400kV D/c (quad) line at Bornagar substation
- (e) Disconnection of Alipurduar – Bongaigaon 400kV D/c (quad) line from Bongaigaon and extension of the same to Bornagar with 400kV D/c (quad) line so as to form Alipurduar – Bornagar 400kV D/c (quad) line

**1.2 Substation****(a) 400kV new substation at Katihar (Bihar) - upgradable to 765kV later**

- **400 kV Line bays: 6 nos.**
  - 2 nos. for Katihar (ER) – Parbotipur (Bangladesh) 765kV D/c line to be initially operated at 400kV
  - 4 nos. for LILO of both ckts of Purnea - Rajarhat 400kV D/c (Triple Snowbird) line at Katihar (one ckt via Gokarna and other ckt via Farakka)
- **Reactive Compensation**
  - 420kV Bus Reactor alongwith associated bays: 2x125 MVAR
  - Shifting of 2 nos. 420kV, 80MVAR switchable Line Reactors at Purnea end of Purnea – Rajarhat 400 kV D/c (Triple) line from Purnea to Katihar end of Katihar – Rajarhat 400 kV D/c (Triple) line [1.1(b)]
- **Space for future 765kV switchyard**
  - 765/400kV 3x1500MVA ICTs (10x500MVA Single Phase Units) along with associated bays
  - 765kV Line bays (including space for sw. line reactor): 8 nos.
  - 765kV, 2x330MVAR (7x110 MVAR) Bus Reactors
- **Space for future 400kV switchyard**
  - 400kV Line bays (including space for sw. line reactor): 6 nos.

- 765/400kV 3x1500MVA ICTs (10x500MVA Single Phase Units) along with associated bays
- 400/220kV, 3x500MVA ICTs along with associated bays
- **Space for future 220kV switchyard**
  - 400/220kV, 3x500MVA ICTs along with associated bays
  - 10 nos. 220 kV line bays

**(b) 400kV new substation at Bornagar (Assam) - upgradable to 765kV later**

- **400 kV Line bays: 8 nos.**
  - 2 nos. for Parbotipur (Bangladesh) - Bornagar (NER) 765kV D/c line to be initially operated at 400 kV
  - 2 nos. for Siliguri/Alipurduar – Bornagar 400kV D/c (quad) line  
[Formed after shifting of Siliguri/Alipurduar – Bongaigaon 400kV D/c (quad) line from Bongaigaon to Bornagar at 1.1(e)]
  - 4 nos. for LILO of both circuits of Balipara - Bongaigaon 400kV D/c (quad) line
- **Reactive Compensation**
  - 420kV Bus Reactor alongwith associated bays: 2x125 MVAR
  - 420kV, 63MVAR switchable line reactor at Bornagar end on each line of Parbotipur (Bangladesh) - Bornagar (NER) 765kV D/c line to be initially operated at 400 kV [1.1(c)]
  - Shifting of 2 nos. 420kV, 80MVAR Line Reactors from Bongaigaon end of Siliguri/Alipurduar – Bongaigaon 400 kV D/c (Quad) line to Bornagar end of Alipurduar – Bornagar 400kV D/c (Quad) line [1.1(e)]
  - Shifting of 2 nos. 420kV, 63MVAR Line Reactors from Bongaigaon end of Balipara – Bongaigaon 400kV D/c (Quad) line to Bornagar end of Bornagar – Balipara 400kV D/c (Quad) line [1.1(d)]
- **Space for future 765kV switchyard**
  - 765/400kV 3x1500MVA ICTs (10x500MVA Single Phase Units) along with associated bays
  - 765kV Line bays (including space for sw. line reactor): 8 nos.
  - 765kV, 2x330MVAR (7x110 MVAR) Bus Reactors
- **Space for 400kV switchyard**
  - 400kV Line bays (including space for sw. line reactor): 6 nos.
  - 765/400kV 3x1500MVA ICTs (10x500MVA Single Phase Units) along with associated bays
  - 400/220kV, 3x500MVA ICTs along with associated bays



- **Space for 220kV switchyard**
  - 400/220kV, 3x500MVA ICTs along with associated bays
  - 10 nos. 220kV line bays

## 2.0 Bangladesh Side

### 2.1 Transmission Lines

- (a) Katihar (ER) – Parbotipur (Bangladesh) 765kV D/c line (to be initially operated at 400kV) – Bangladesh Portion only
- (b) Parbotipur (Bangladesh) – Bornagar (NER) 765kV D/c line (to be initially operated at 400kV) – Bangladesh Portion only
- (c) LILO of Barapukuria – Bogra 230kV D/c line at Parbotipur

### 2.2 Substation

#### (a) 400/230kV new substation at Parbotipur - upgradable to 765kV later

- **500MW Back-to-Back HVDC Station**
- **400kV Line bays: 4 nos.**
  - 2 nos. 400kV line bays for Parbotipur (Bangladesh) – Katihar (ER) 765kV D/c line to be initially operated at 400kV
  - 2 nos. 400kV line bays for Parbotipur (Bangladesh) – Bornagar (NER) 765kV D/c line to be initially operated at 400kV
- **Reactive Compensation**
  - 420kV, 2x125 MVAR Bus Reactor alongwith associated bays
  - 420kV, 63 MVAR Switchable Line Reactor at Parbotipur end on each line of Parbotipur (Bangladesh) – Katihar (ER) 765kV D/c line to be initially operated at 400kV [2.1(a)]
  - 420kV, 63 MVAR Switchable line Reactor at Parbotipur end on each line of Parbotipur (Bangladesh) – Bornagar (NER) 765kV D/c line to be initially operated at 400kV [2.1(b)]
- 400/230kV, 2x600MVA (7x200 MVA single phase units) ICTs along with associated bays
- 230kV Line bays:
  - 4 nos. 230kV line bays for LILO of Barapukuria – Bogra 230 kV D/c line at Parbotipur
- **Space for future 765kV switchyard**
  - 765/400kV, 2x1500 MVA ICTs (7x500 MVA Single Phase Units) along with associated bays
  - 765kV Line bays: 8 nos.
  - 765kV, 2x330 MVAR (7x110 MVAR) Bus Reactors

- **Space for future HVDC / 400kV / 230kV switchyard**
  - 500MW HVDC Back-to-Back 2<sup>nd</sup> block at Parbotipur
  - 765/400kV, 2x1500 MVA ICTs (7x500 MVA Single Phase Units) along with associated bays
  - Capacity enhancement of 400/230kV Parbotipur substation by 600MVA (3x200MVA single phase ICTs) alongwith associated bays
  - 400kV Line Bays: 4 nos.
  - 230kV Line Bays: 8 nos. [including 2 nos. line bays for Parbotipur – Bogra – Kaliakoir 400kV (to be energized at 230kV) D/c line]

### 3.0 Schematic Diagram

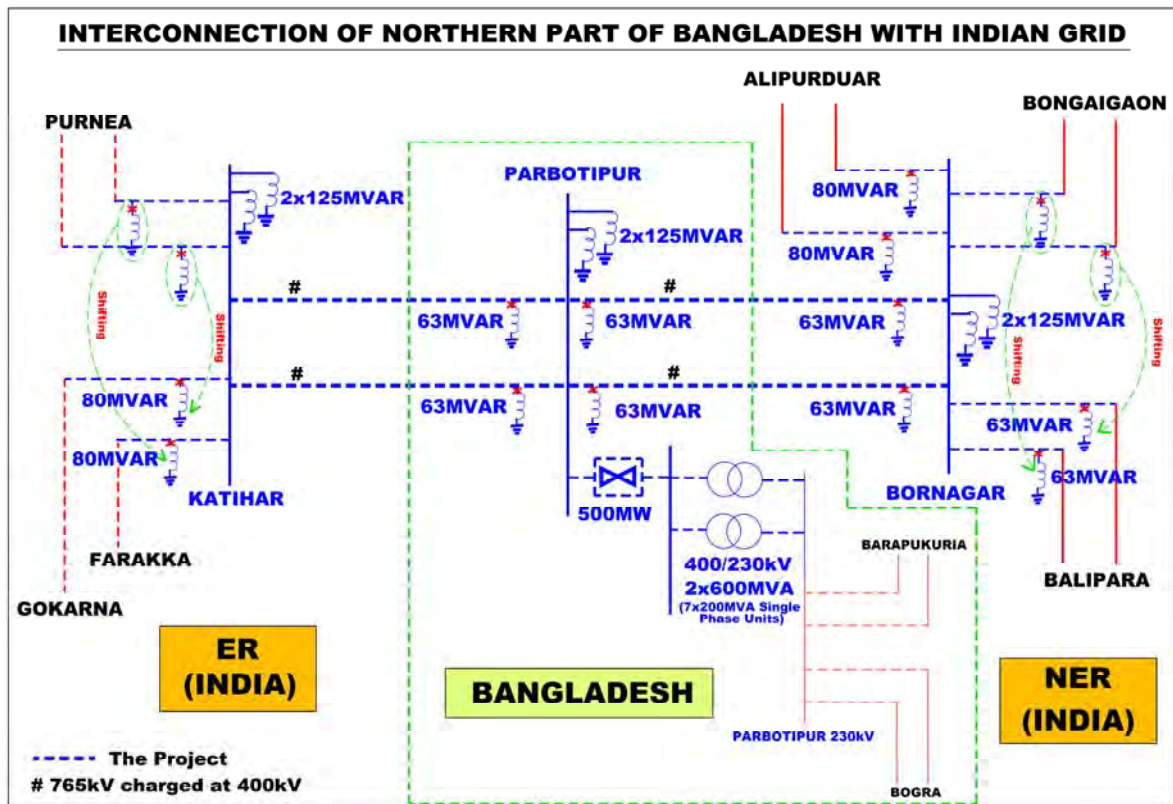

## Transmission system for Odisha UMPP

### Introduction:

Orissa Integrated Power Limited (SPV for Odisha UMPP) has applied for LTA of 4000MW from Odisha UMPP (Bhedabahal, Odisha) with the following allocation:

Beneficiary	Quantum (MW)
Odisha	1300 MW
<b>ER</b>	<b>1300 MW</b>
Madhya Pradesh	400 MW
Chhattisgarh	200 MW
<b>WR</b>	<b>600 MW</b>
Tamil Nadu	300 MW
<b>SR</b>	<b>300 MW</b>
Rajasthan	400 MW
Uttarakhand	200 MW
Punjab	500 MW
Haryana	400 MW
Uttar Pradesh	300 MW
<b>NR</b>	<b>1800 MW</b>
<b>Total</b>	<b>4000 MW</b>

Odisha UMPP (4000MW) is expected to be commissioned by 2021-22 time-frame. Accordingly, studies have been carried out for 2021-22 time-frame to finalise transmission system for evacuation of power from Odisha UMPP.

### Transmission System:

It has been assumed that Odisha UMPP shall consist of 6 generation units of 660MW each. As per coordinates provided, UMPP shall be established in proximity of the existing 765/400kV Sundargarh (Jharsuguda) substation of POWERGRID. On connecting the generation project to Sundargarh 765/400kV S/s, it was found that the fault levels were exceeding the rated limits. Thus, in order to control the fault level, split bus arrangement has been considered at UMPP switchyard with two bus sections having 3 generation units of 660MW each.

From the above mentioned power allocation it is observed that about 1800MW is to be transferred to beneficiaries in NR and about 600MW to WR. Accordingly, it is proposed that high capacity 765kV AC transmission lines be planned from Odisha UMPP in such a manner that power could be transferred to two routes viz. from ER to WR and from ER to NR.

Accordingly, the following alternatives have been considered:

### Alternative-1 (transmission system approved in 17<sup>th</sup> ER-SCM) [Study Results at Exhibit-1]

- Establishment of new 765/400kV 3x1500MVA Pooling Station near Sundargarh
- LILO of Sundargarh-A – Raipur Pool 765 kV D/c line at Sundargarh (New)
- Odisha UMPP – Sundargarh New 765kV 2xD/c line
- Establishment of new 400/220kV 4x500MVA Station at Badarpur (New)
- Sundargarh (New) – Badarpur (New) ±800kV HVDC Bipole Line
- ±800kV HVDC 3000MW (upgradable to 6000MW in future) Terminals at Sundargarh (New) and Badarpur (New)

Due to space constraint at 765kV bus section at Sundargarh-A, LILO of either Sundargarh-A – Dharamjaygarh 765kV D/c line or Sundargarh-A – Raipur Pool 765kV D/c line has been considered at one section of Odisha UMPP switchyard. The other section of Odisha UMPP switchyard is proposed to be connected to either Sundargarh-B section or alternatively to Gaya S/s via Ranchi (New) for transfer of power towards NR.

#### **Alternative-2 [Study Results at Exhibit-2(a) & 2(b)]**

- Split bus at Odisha UMPP (3x660MW in Section-A and 3x660MW in Section-B)
  - LILO of Sundargarh-A – Dharamjaygarh 765kV D/c line at Odisha UMPP-A
- Or**
- LILO of Sundargarh-A – Raipur Pool 765kV D/c line at Odisha UMPP-A
  - Odisha UMPP-B to Sundargarh-B 765kV D/c line
  - Ranchi (New) – Gaya 765kV D/c line

#### **Alternative-3 [Study Results at Exhibit-3]**

- Split bus at Odisha UMPP (3x660MW in section-A and 3x660MW in Section-B)
  - LILO of Sundargarh-A – Dharamjaygarh 765kV D/c line at Odisha UMPP-A
- Or**
- LILO of Sundargarh-A – Raipur Pool 765kV D/c line at Odisha UMPP-A
  - Odisha UMPP-B to Ranchi (New) 765kV D/c line
  - Ranchi (New) – Gaya 765kV D/c line

#### **Observations:**

From the above study results, it is observed that power flow in all the alternatives are within acceptable limits. However, following are the observations for the above mentioned alternatives:

#### **Alternative-1:**

It is observed that existing/under-construction evacuation corridors from Sundargarh (Jharsuguda) are under-utilized. Further, as the expected cost of this alternative would be high, this alternative does not appear to be the optimised transmission system.

#### **Alternative-2:**

It is observed that loading of transmission lines is similar whether LILO of Sundargarh-A – Dharamjaygarh 765 kV D/c line is considered at Odisha UMPP-A or LILO of Sundargarh-A – Raipur Pool 765 kV D/c line is considered at Odisha UMPP-A section. Therefore, it is proposed that LILO of one of the 765kV D/c lines be done at Odisha UMPP-A bus section depending on the proximity of transmission line route from the UMPP. Odisha UMPP-B is proposed to be connected to Sundargarh-B through 765kV D/c line

The power flows from Sundargarh-A and Sundargarh-B sections to Ranchi (New) via Dharamjaygarh substation in WR through Sundargarh – Dharamjaygarh – Ranchi (New) 765kV corridor. Further, there is a high capacity 765kV ER-NR corridor from Gaya in ER to Varanasi and Balia substations in NR. Thus, by completing the missing link i.e. Ranchi (New) – Gaya 765 kV D/c line, it shall be possible to connect southern and northern portion of ER through strong 765kV link and this shall enhance power flow on WR-ER-NR and ER-NR corridors and also increase utilisation of the existing transmission capacity in ER-NR corridor in a better way.

Further, in Alternative-2 by construction of Ranchi (New) – Gaya 765 kV D/c line, the Sundargarh-A – Odisha UMPP-A – Dharamjaygarh – Ranchi (New) – Gaya – Varanasi/Balia 765kV corridor gets completed.

### **Alternative-3:**

In this alternative, Odisha UMPP-A section is proposed to be connected same as mentioned in Alternative-2. However, in order to push more power through ER-NR corridor, Odisha UMPP-B bus section has been directly connected to Ranchi (New) through 765kV D/c line along with extension of 765kV D/c corridor to Gaya for further transfer of power to Varanasi and Balia substations in Northern Region.

Power flow on the existing Dharamjaygarh – Ranchi (New) 765kV 2xS/c lines is low in the base case itself. With construction of UMPP to Ranchi corridor it is observed that power flow on Dharamjaygarh – Ranchi (New) link is further reduced, as the two corridors become a parallel path (UMPP – Ranchi and UMPP – Dharamjaygarh – Ranchi).

### **Conclusion:**

From above, Alternative-2 is found to be the most optimised/suitable one. In this alternative only by construction of Ranchi (New) – Gaya 765 kV D/c line, power flow in WR-ER-NR and ER-NR corridors is enhanced. This shall also result in better utilisation of existing and under construction inter-regional transmission lines.

Accordingly, following transmission system is proposed for Odisha UMPP:

- Split bus at Odisha UMPP (3x660MW in Section-A and 3x660MW in Section-B)
- LILO of Sundargarh-A – Dharamjaygarh 765kV D/c line at Odisha UMPP-A

**Or**

- LILO of Sundargarh-A – Raipur Pool 765kV D/c line at Odisha UMPP-A
- Odisha UMPP-B to Sundargarh-B 765kV D/c line
- Ranchi (New) – Gaya 765kV D/c line

# POWER MAP OF EASTERN REGION

Odisha UMPP Study

Alt-1: HVDC Bipole - Jharsuguda New - Badarpur



पावरग्रिड

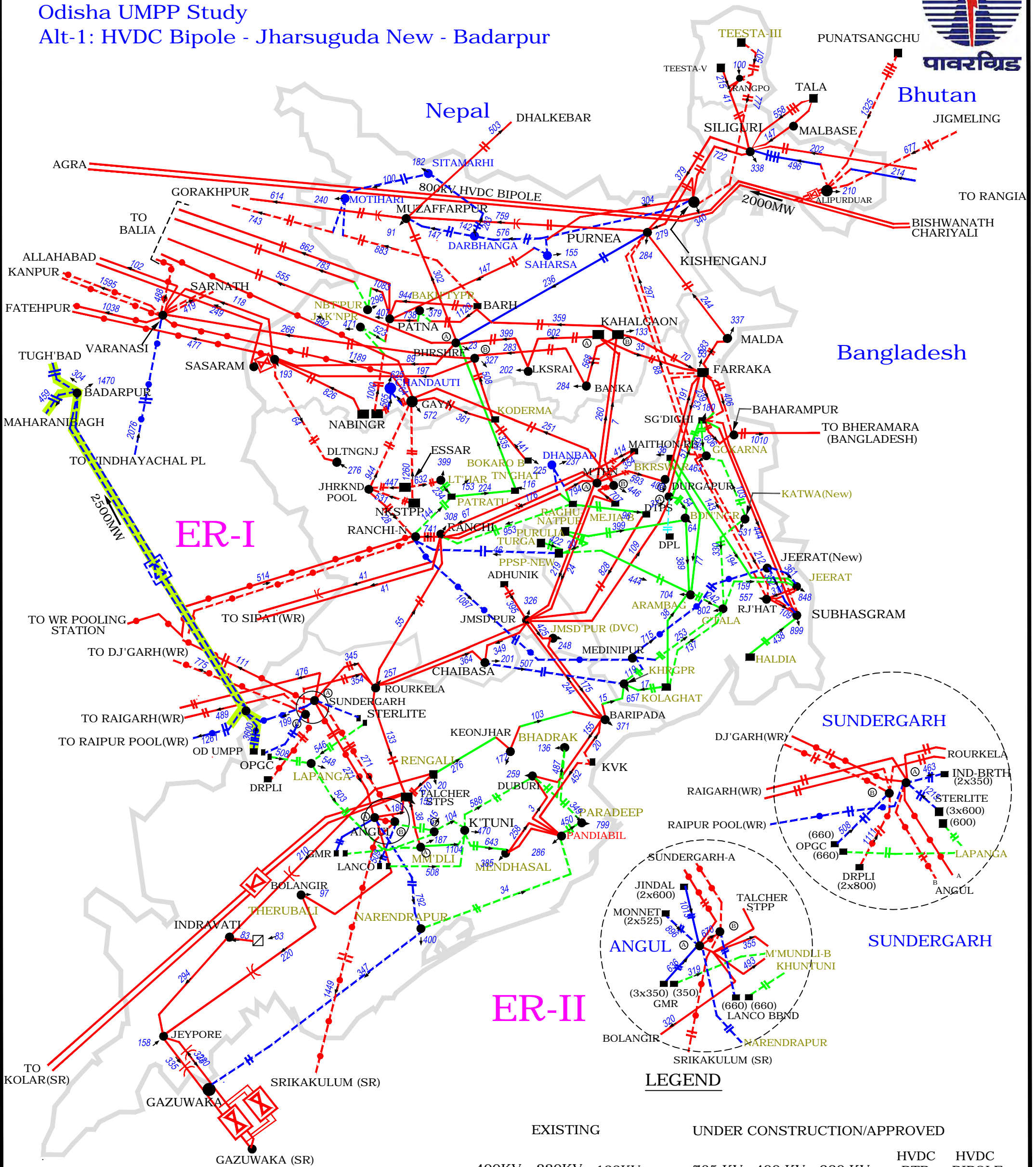

ER-I

ER-II

**LEGEND**

	EXISTING			UNDER CONSTRUCTION/APPROVED			HVDC BTB	HVDC BIPOLE
POWERGRID	400KV	220KV	132KV	765 KV	400 KV	220 KV		
TBCB								
SEB								

TIME FRAME: 2021-22

R:\NER & NER\ER\PSSE\REGION\Odisha Strengthening and UMPP\Study files\ump\Final

Last Updated  
06 July 2016

# POWER MAP OF EASTERN REGION



**Odisha UMPP Study**  
**Alt:2 LILO of Jhar-A - Dharam. & Jharsuguda - B**  
**Ranchi (New) - Gaya 765 kV D/c**

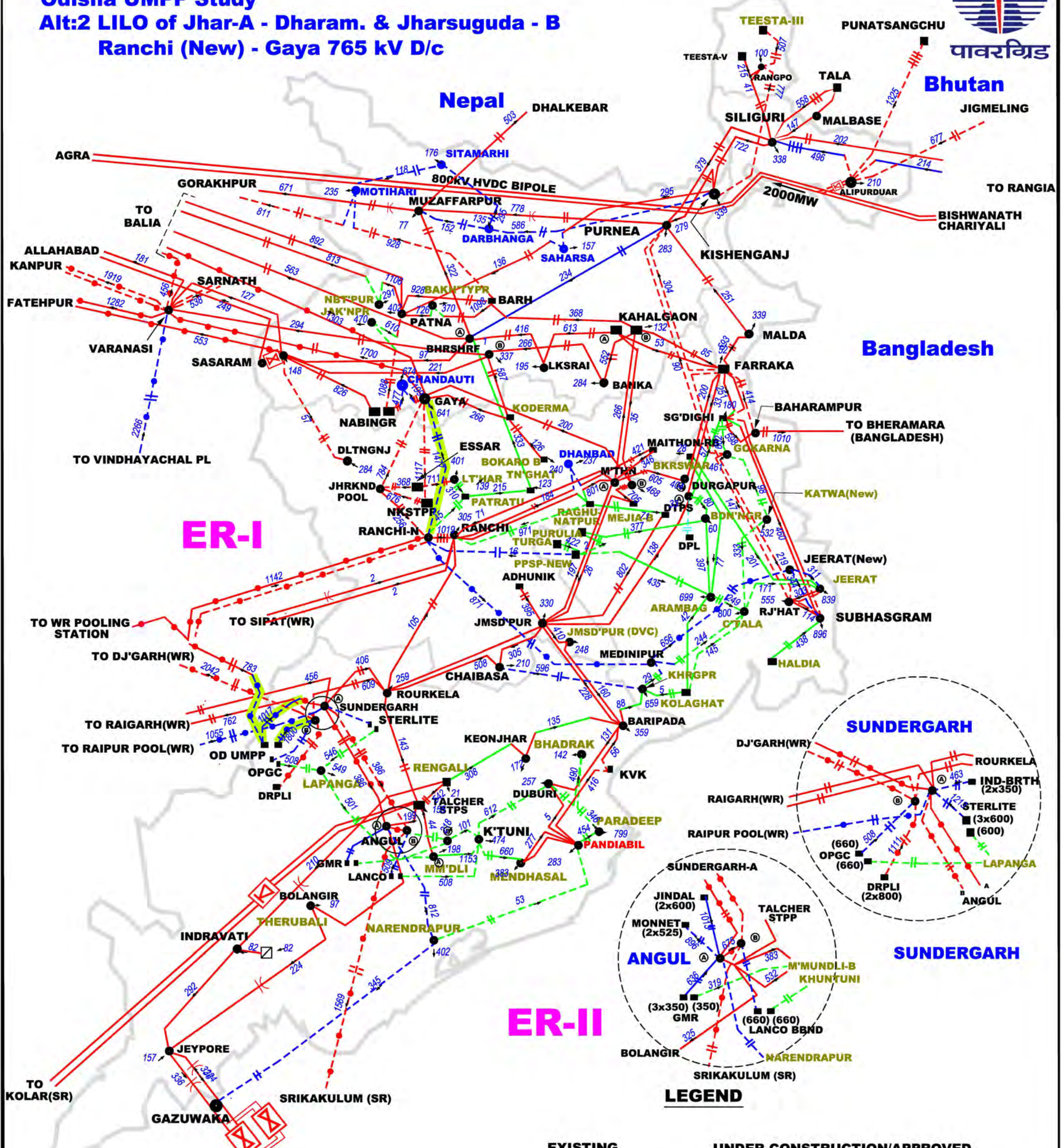

**ER-I**

**ER-II**

**LEGEND**

	EXISTING			UNDER CONSTRUCTION/APPROVED			HVDC BTB	HVDC BIPOLE
400KV	[Solid Red Line]	[Solid Blue Line]	[Solid Green Line]	[Dashed Red Line]	[Dashed Blue Line]	[Dashed Green Line]	[Red Box with X]	[Blue Box with X]
220KV	[Solid Red Line]	[Solid Blue Line]	[Solid Green Line]	[Dashed Red Line]	[Dashed Blue Line]	[Dashed Green Line]	[Red Box with X]	[Blue Box with X]
132KV	[Solid Red Line]	[Solid Blue Line]	[Solid Green Line]	[Dashed Red Line]	[Dashed Blue Line]	[Dashed Green Line]	[Red Box with X]	[Blue Box with X]
765 KV	[Solid Red Line]	[Solid Blue Line]	[Solid Green Line]	[Dashed Red Line]	[Dashed Blue Line]	[Dashed Green Line]	[Red Box with X]	[Blue Box with X]
400 KV	[Solid Red Line]	[Solid Blue Line]	[Solid Green Line]	[Dashed Red Line]	[Dashed Blue Line]	[Dashed Green Line]	[Red Box with X]	[Blue Box with X]
220 KV	[Solid Red Line]	[Solid Blue Line]	[Solid Green Line]	[Dashed Red Line]	[Dashed Blue Line]	[Dashed Green Line]	[Red Box with X]	[Blue Box with X]

**TIME FRAME: 2021-22**

R:\ER & NER\ER\PSSE\REGION\Odisha Strengthening and UMPP\Study files\umpp\Final

**Last Updated**  
**06 July 2016**

# POWER MAP OF EASTERN REGION

Odisha UMPP Study

Alt 2a: LILO of Jhar-A - Raipur Pool & Jharsuguda - B

Ranchi (New) - Gaya 765 kV D/c



पावरग्रिड

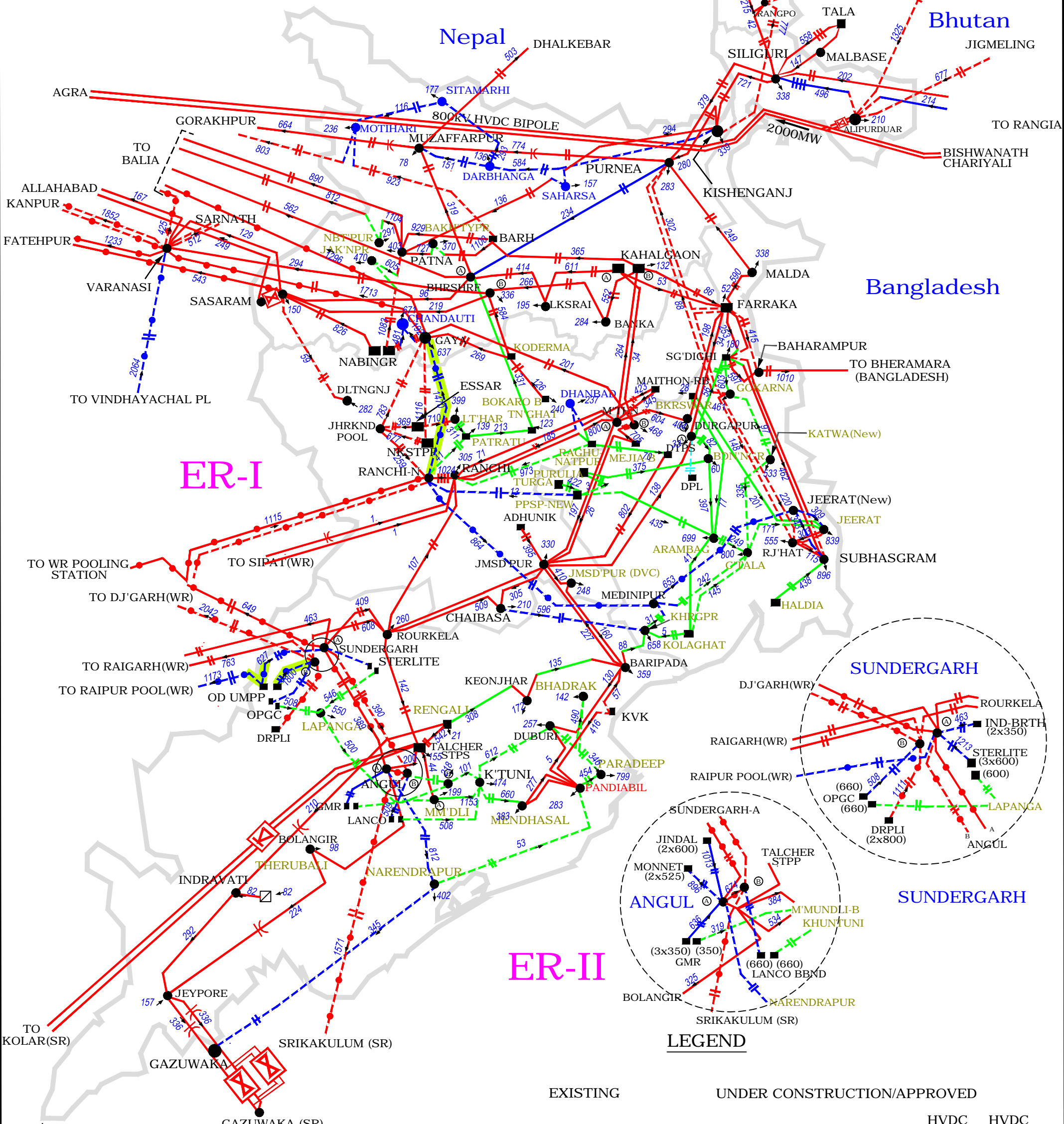

ER-I

ER-II

**LEGEND**

	EXISTING			UNDER CONSTRUCTION/APPROVED			HVDC BTB	HVDC BIPOLE
400KV								
220KV								
132KV								
POWERGRID								
TBCB								
SEB								

TIME FRAME: 2021-22

R:\ER & NER\ER\PSSE\REGION\Odisha Strengthening and UMPP\Study files\umpp\Final

Last Updated 06 July 2016



# POWER MAP OF EASTERN REGION



**Odisha UMPP Study**  
**Alt-3: LILO of Jhar-A - Dharamjaygarh & Ranchi (New)**  
**Ranchi (New) - Gaya 765 kV D/c**

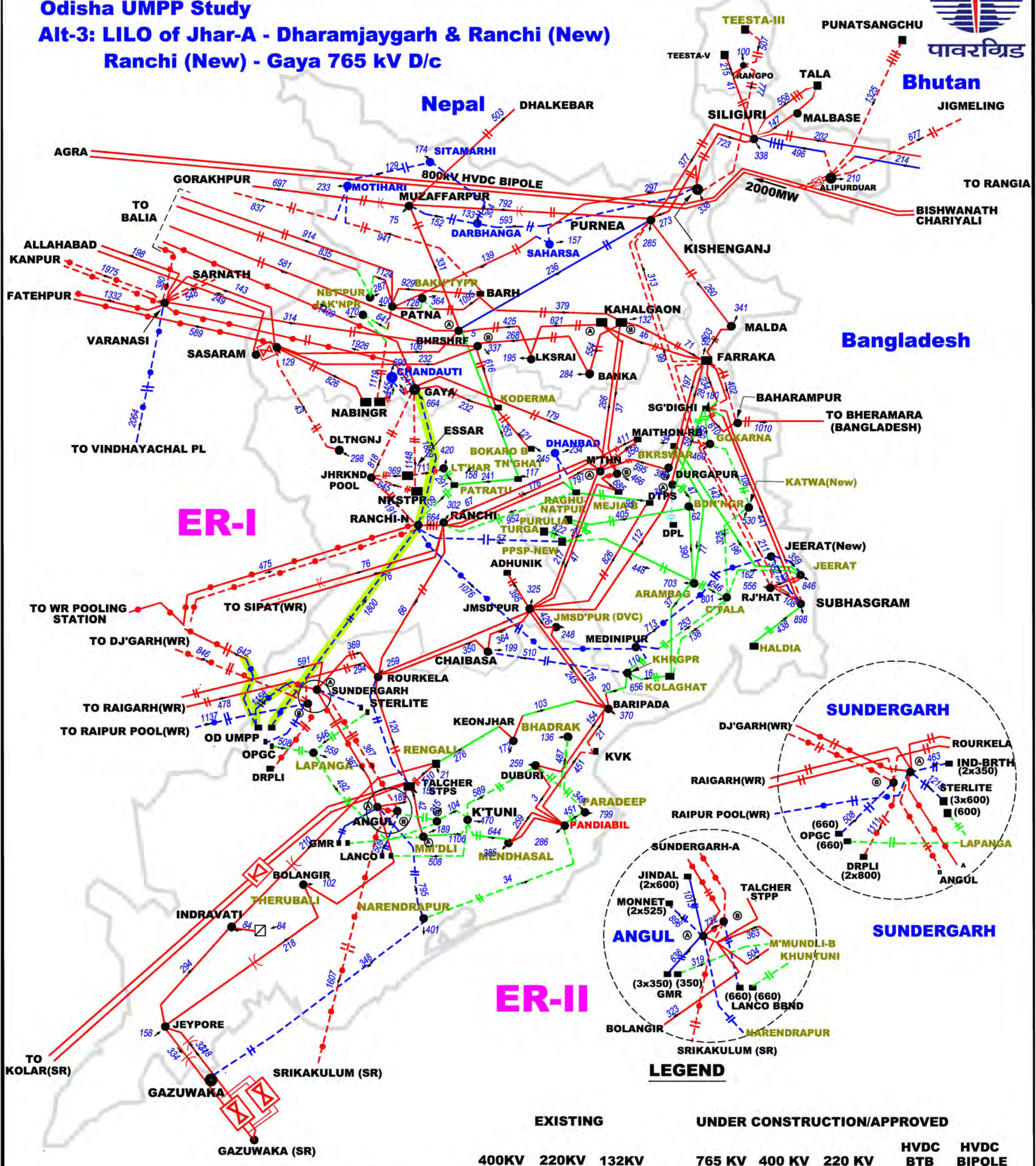

**ER-I**

**ER-II**

**LEGEND**

	EXISTING			UNDER CONSTRUCTION/APPROVED			HVDC BTB	HVDC BIPOLE
400KV	[Solid Red Line]	[Solid Blue Line]	[Solid Green Line]	[Dashed Red Line]	[Dashed Blue Line]	[Dashed Green Line]	[Red Box with X]	[Red Box with Double X]
220KV	[Solid Red Line]	[Solid Blue Line]	[Solid Green Line]	[Dashed Red Line]	[Dashed Blue Line]	[Dashed Green Line]	[Red Box with X]	[Red Box with Double X]
132KV	[Solid Red Line]	[Solid Blue Line]	[Solid Green Line]	[Dashed Red Line]	[Dashed Blue Line]	[Dashed Green Line]	[Red Box with X]	[Red Box with Double X]
765 KV	[Solid Red Line]	[Solid Blue Line]	[Solid Green Line]	[Dashed Red Line]	[Dashed Blue Line]	[Dashed Green Line]	[Red Box with X]	[Red Box with Double X]
400 KV	[Solid Red Line]	[Solid Blue Line]	[Solid Green Line]	[Dashed Red Line]	[Dashed Blue Line]	[Dashed Green Line]	[Red Box with X]	[Red Box with Double X]
220 KV	[Solid Red Line]	[Solid Blue Line]	[Solid Green Line]	[Dashed Red Line]	[Dashed Blue Line]	[Dashed Green Line]	[Red Box with X]	[Red Box with Double X]

**TIME FRAME: 2021-22**

R:\ER & NER\ER\PSSE\REGION\Odisha Strengthening and UMPP\Study files\umppl\Final

**Last Updated**  
**06 July 2016**



सत्यमेव जयते

भारत सरकार  
Government of India

विद्युत मंत्रालय

Ministry of Power

केंद्रीय विद्युत प्राधिकरण

Central Electricity Authority

विद्युत प्रणाली योजना एवं मूल्यांकन प्रभाग-II

Power System Planning &amp; Appraisal Division-II

No: 75/1/PSPA-II/2017/ 496-503

Dated: 06.07.2017

To

As per address list

**Subject:** Minutes of Meeting regarding 132kV Banka (PG) – Deoghar D/c transmission line.

Sir,

Meeting regarding 132kV Banka (PG) – Deoghar D/c transmission line held on 13.06.2017 at CEA, New Delhi. Minutes of the meeting is enclosed herewith.

**JUSNL is requested to send their comments/observations, if any, in regard to dropping of proposed Banka (PG) – Deoghar 132kV D/c line.**

Yours faithfully,

*Rishika Sharan*  
6/7/2017  
(Rishika Sharan)  
Director (PSPA-II)

**List of addressee:**

1. Member Secretary Eastern Regional Power Committee 14, Golf Club Road, Tollygunge Kolkata – 700033 Fax No. 033-24171358	2. Managing Director, Bihar State Power Transmission Co. Ltd., Vidyut Bhawan, Bailey Road, Patna-800021 Telefax: 0612-2504968
3. Managing Director, Jharkhand Urja Sancharan Nigam Limited Engineering Building, H.E.C., Dhurwa, Ranchi-834004. Fax-0651-2400799	4. Chief Electrical Engineer, Eastern Railway, 17-NS Road, Kolkata-700 001 (fax no.: 033-22300446)
5. COO(CTU-Plg), Power Grid Corp. of India Ltd. "Saudamini", Plot No.2, Sector-29, Gurgaon 122 001, Haryana. FAX : 95124-2571932	6. CEO, POSOCO B-9, Qutub Institutional Area, Katwaria Sarai, New Delhi-110016

Copy to: PPS to Member (Power System) - for kind information please.

**Minutes of Meeting regarding 132kV Banka (PG) – Deoghar D/c transmission line  
held on 13.06.2017 at CEA**

List of participants is enclosed at **Annexure-1**

1. Chief Engineer (PSPA-II), CEA welcomed the participants and highlighted about the purpose of the meeting. He informed that Banka (PG) - Deoghar 132kV D/C line (about 40 km) was agreed in the 01<sup>st</sup> -2014 Standing Committee Meeting on Power System Planning in Eastern Region(ER) (16<sup>th</sup> SCMPSP(ER)) held on 02<sup>nd</sup> May 2014.
2. In the 16<sup>th</sup> SCM meeting, ERPC had informed that the 132kV Deoghar S/S (JSEB) is being fed through 132kV line(s) from DVC source (132kV Maithon-Jamtara-Deoghar S/C) or from NTPC source (Lalmatia). There is also a feed from BSPTCL source through 132kV Sultanganj- Deoghar S/C line, which is normally kept open due to overloading in Kahalgaon-Sabour- Sultanganj section of BSPTCL system. The Deoghar & Jamtara sub-stations feed important railway loads of 10MW each to Shankarpur TSS & Jamtara TSS and loading on Maithon – Jamtara – Deoghar 132kV S/C line sometimes exceeds 75MW. The reliability of supply to railway loads is being affected. In view of above, it was agreed to provide an additional supply to Deoghar S/S (JSEB) from 400/132kV Banka S/S (PG) by creating a 132kV Banka- Deoghar D/C lines (about 40 Kms).
3. JUSNL vide their letter dated 30.07.2015 addressed to POWERGRID(copy enclosed at Annex-II) informed that termination of above line at Deoghar is not possible due to space constraint. Further, JUSNL informed that after commissioning of 132kV Jasidih – Deoghar line (about 5km); Deoghar S/s will be able to receive 250MVA of power through Jasidih S/s and Dumka S/s, whereas the transformation capacity at Deoghar is only 150MVA. The matter was discussed in 18<sup>th</sup> SCMPSP(ER) meeting and it was decided to review the possible interconnections at Deoghar in a separate meeting at CEA with Railways & other stakeholders.
4. In the meeting, representative of BSPTCL stated that Banka (PG) substation is having 2x200 MVA 400/132 kV ICTs at present, which are sufficient to meet the loads of BSPTCL only. PGCIL informed that Banka substation is proposed to be augmented with addition of 1x315 MVA, 400/132kV ICT under ERSS-XX (approved in 18<sup>th</sup> SCMPSP(ER)). BSPTCL representative suggested that power supply to Deoghar (Jharkhand) from Banka (PG) may be commenced only after commissioning of additional 315 MVA ICT at Banka (PG), which is planned under 13<sup>th</sup> plan.
5. Chief Engineer (PSPA-II), CEA enquired about reason for keeping 132kV Sultanganj- Deoghar S/C line open under normal condition.
6. Representative of BSPTCL stated that BSPTCL can supply power with exiting system to Deoghar (Jharkhand) through the above line during off-peak hours only, as the bus bars capacity at Sultanganj is inadequate. However, supply

during peak hours would be possible only after strengthening of bus bar at Sultanganj, which is likely to be completed in next 6 months.

7. Representative of CTU informed that POWERGRID has closed the ERSS-XVI project involving construction of Banka (PG) - Deoghar 132kV D/C line and the same was informed to CEA vide letter dated 27-10-2016.
8. Chief Engineer (PSPA-II), CEA expressed that in absence of representatives from JUSNL (Jharkhand) and Railways, it is difficult to assess the loading of the network in present situation.
9. Thus, the proposed Deoghar-Jasidih 132kV D/C line (by JUSNL) and strengthening of 132kV bus at Sultanganj (by BSPTCL) are likely to enhance the reliability of power supply to the Railways TSS at Deoghar. In view of above, it was decided to drop the proposal of construction of Banka (PG) - Deoghar 132kV D/C line in the next Standing Committee meeting.

**Annexure-I**

**List of the participants of the meeting held on 13.06.2017 at CEA**

<b>Sl. No.</b>	<b>Name of the Participant</b>	<b>Designation</b>	<b>Organization</b>
1	S.K.Ray Mohapatra	Chief Engineer, (PSPA-II)	CEA
2	Sanjay Srivastava	Chief Engineer, (PSE&TD)	CEA
3	Uma Maheswara Rao	Dy. Director, (PSPA-II)	CEA
4	Ashok Pal	General Manager(CTU-Plg)	POWERGRID
5	Manish Ranjan Keshari	Sr. Engineer(CTU-Plg)	POWERGRID
6	N.Nallarasan	Dy. General Manager	POSOCO
7	Pankaj Kumar	ESE	BSPTCL
8	Premjeet Kumar	ESE	BSPTCL

# Jharkhand Urja Sanchran Nigam Ltd.

Office of the  
General Manager Cum Chief Engineer  
Transmission Zone - II, Dumka

Letter No. 390/G.M (T)

Dumka, Dated 30/07/2015

From,

Er. R. N. Singh  
General Manager Cum Chief Engineer

To,

AGM (Engg-S/S)  
(Sri A.P. Gangadharan)  
Power Grid

**Sub :- Termination of 132 kV D/C Banks (Power Grid) – Deoghar Transmission line.**

*Ref :- Your office letter no. C/Eng/SS/ERSS-XVI/ dated 30.4.2015.*

Sir,

With reference to above subject, letter of field officers and single line diagram of 132/33 kV GSS, Deoghar are enclosed. It was requested to visit the Grid Sub-Station Deoghar and to have an idea of associated Transmission lines in this regard. Now, with the commissioning of 220 kV Rupnarayanpur – Dumka Transmission line and 220/132 kV GSS Dumka, Power for 132/33 kV GSS is availed from Rupnarayanpur through Dumka 132 kV S/C Sultanganj (Bihar) 132 kV S/C Maithan – Jamtara – Deoghar are alternate sources. At present 132 kV S/C Railway Deoghar-Shankarpur is supplied power from DVC.

Although space in switchyard and control room along with 2 no. feeders in 415 V and 2 no. of 220 V DC feeders may also be available. But in view of the present system it may be reanalyzed regarding the usability of termination at GSS Deoghar or proposed adjacent GSS Jasidih.

Yours faithfully,

*R.N. Singh*  
30/7/15  
(Er. R. N. Singh)

General Manager cum Chief Engineer

# Jharkhand Urja Sancharan Nigam Limited

(CIN : U40108 JH 2013 SGC 001704)

Regd. Office – Engineering Building, HEC Dhurwa, Ranchi- 834004

Office of the

**Electrical Superintending Engineer.**

Transmission Circle,

Deoghar

Letter No. ...*188*.../ ESE (T)

Deoghar dated- ...*08/05*.../ 15

From,

Er. B. P. Bhagat,

Electrical Superintending Engineer.

To,

The General Manager cum Chief Engineer,

Transmission Zone- II, Dumka.

**Sub :- Regarding Termination of 132 kV Banka – Deoghar Transmission Line at Grid Sub Station, Deoghar.**

Sir,

With reference to above, please find enclosed herewith the Termination of 132 kV Banka – Deoghar Transmission line at Grid Sub Station, Deoghar submitted by Assistant Executive Engineer, Transmission Sub Division, Deoghar and duly signed by Electrical Executive Engineer, Transmission Division, Deoghar- I for your kind information and necessary

action. *The proposal submitted by Electrical Ex. Engineer*

*To. Div. Deoghar-I is recommended.*  
Encl :- As above.

Yours faithfully,

*B.P. Bhagat*  
*08/05/15*

(B.P. Bhagat)

Electrical Superintending Engineer

### Termination of 132 kV Banka –Deoghar Tr Line at GSS Deoghar

Presently, Transformation capacity of GSS Deoghar is 100 MVA and its capacity becomes 150 MVA after installation of 3<sup>rd</sup> No Transformer by the end of this year which will be the highest Transformation capacity due to space unavailability at GSS Deoghar.

This Grid has been availing power from D/C Dumka –Deoghar Tr line, S/C Sultanganj-Deoghar Tr Line & S/C Jamtara-Deoghar Tr line. Generally, S/C Sultanganj-Deoghar Tr line remain in idle charging. The 132 kV main bus has been sectionalized by High level isolator due to incoming Power comes from Dumka Tr line & Jamtara Tr Line is not synchronized.

As 220/132/33 kV GSS Dumka is under construction and it is likely to be completed upto end of this year also Proposal for construction of 220/132/33 kV GSS Jasidih is under progress. Proposal for Commissioning of Two Nos 132 kV feeder at GSS Deoghar for receiving power from Proposed 220/132/33 kV GSS Jasidih has been under progress also.

As such Deoghar Grid will be capable to received power approximately to 250 MVA from GSS Dumka & GSS Jasidih which is enough for this Grid because maximum Transformation capacity is 150 MVA only. Also no space will be left in switchyard and control room for further commissioning of new panel & bays.

Hence, it is requested that proposal of Termination of 132 kV Banka- Deoghar Tr Line may be terminated to GSS Jasidih instead of GSS Deoghar. In proposed Jasidih GSS sufficient space is available for Termination of 132 kV Banka-Deoghar Tr line. Distance between GSS Jasidih & GSS Deoghar is only 5 km(approx.). So, that Deoghar Grid will be avail Power from 132 kV Banka-Deoghar Tr line also via GSS Jasidih without creating any mess.

*A. K. Majhi*  
09/05/15

AEE

Trans S/D Deoghar

*R. K. Das*  
09/05/15

EEE

Trans Div Deoghar-I

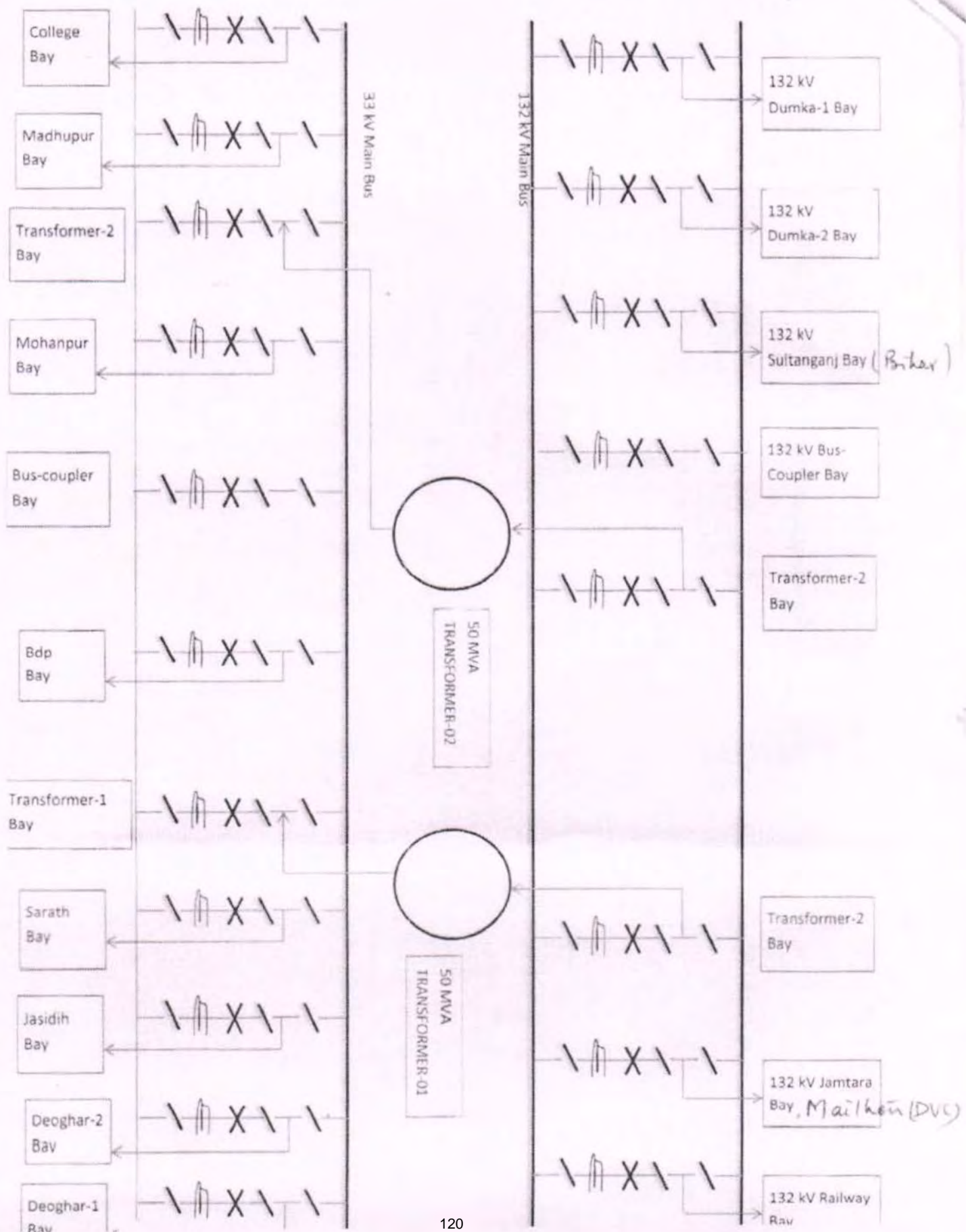



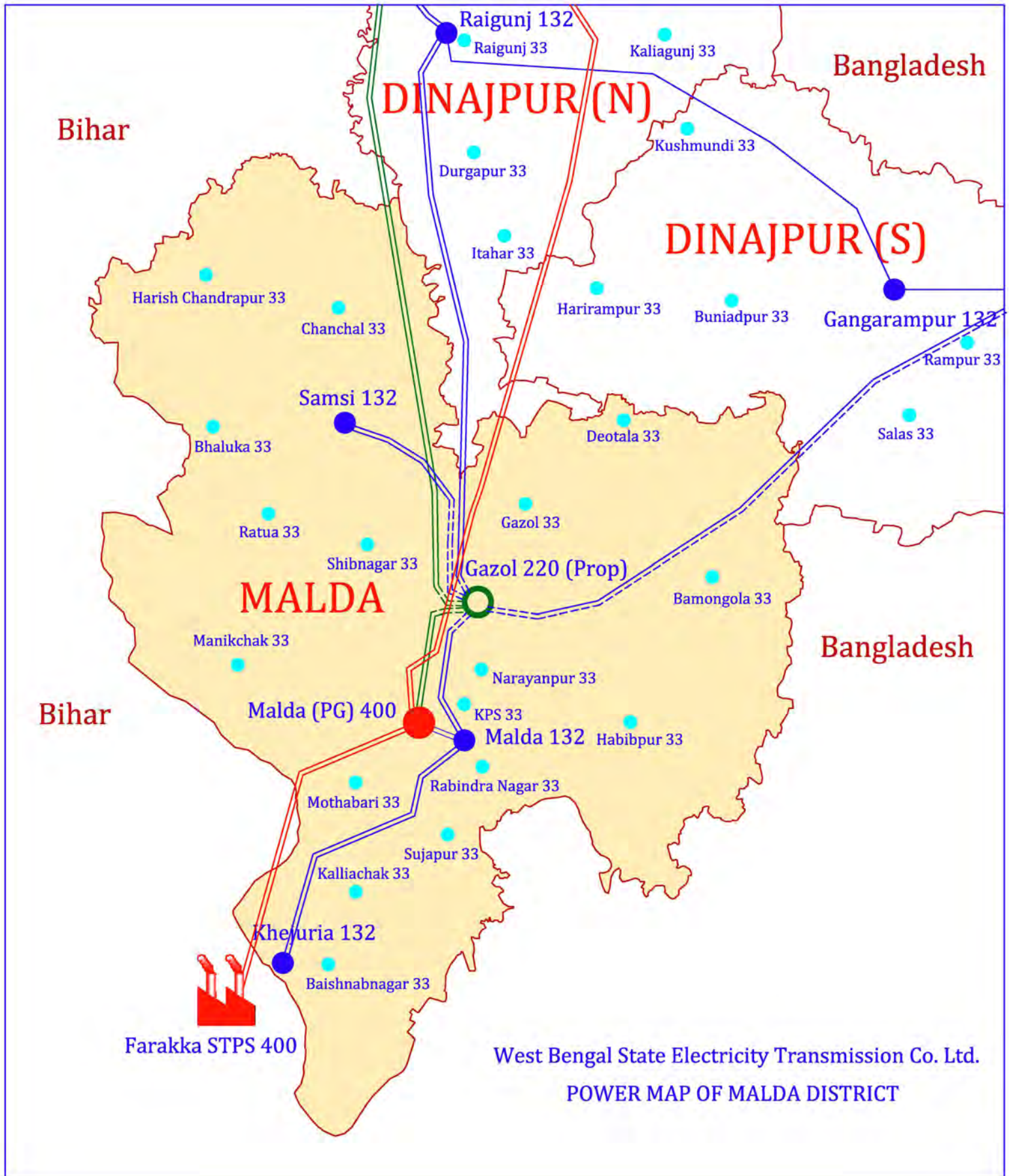

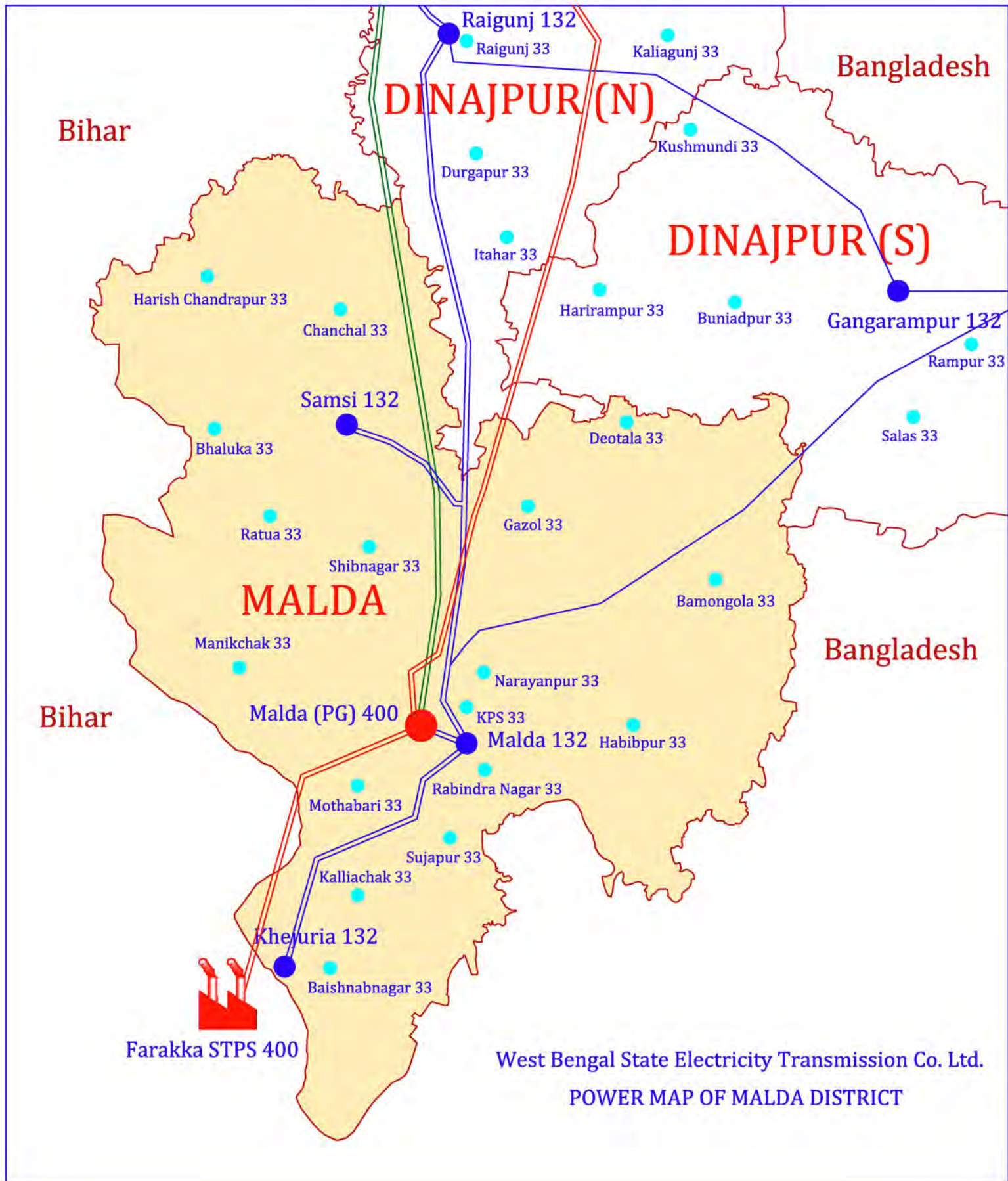

West Bengal State Electricity Transmission Co. Ltd.  
**POWER MAP OF MALDA DISTRICT**

# ODISHA TRANSMISSION SYSTEM WITH PROPOSED SYSTEM OF ODISHA Base Case

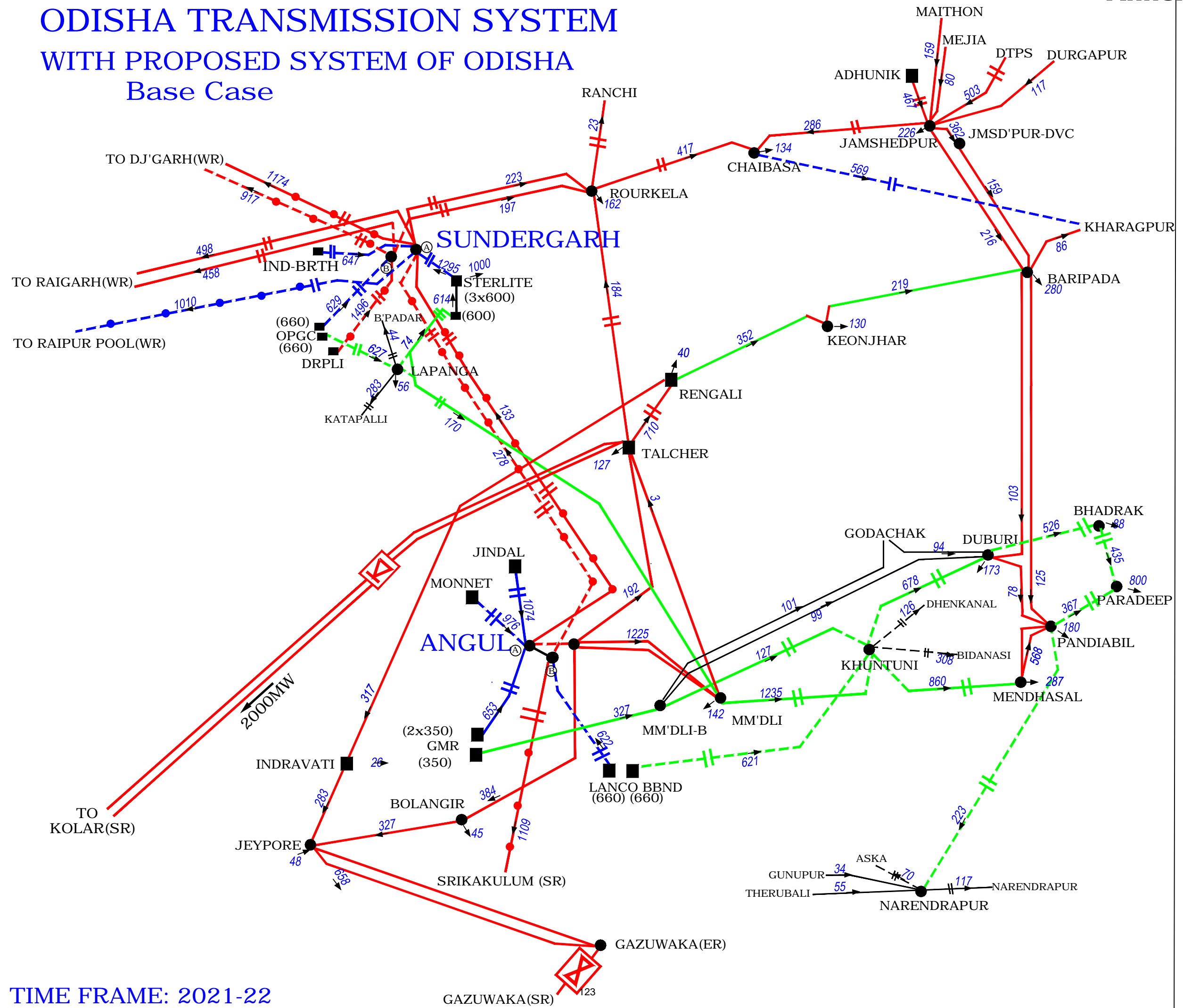

TIME FRAME: 2021-22

# ODISHA TRANSMISSION SYSTEM WITH PROPOSED SYSTEM OF ODISHA Angul case

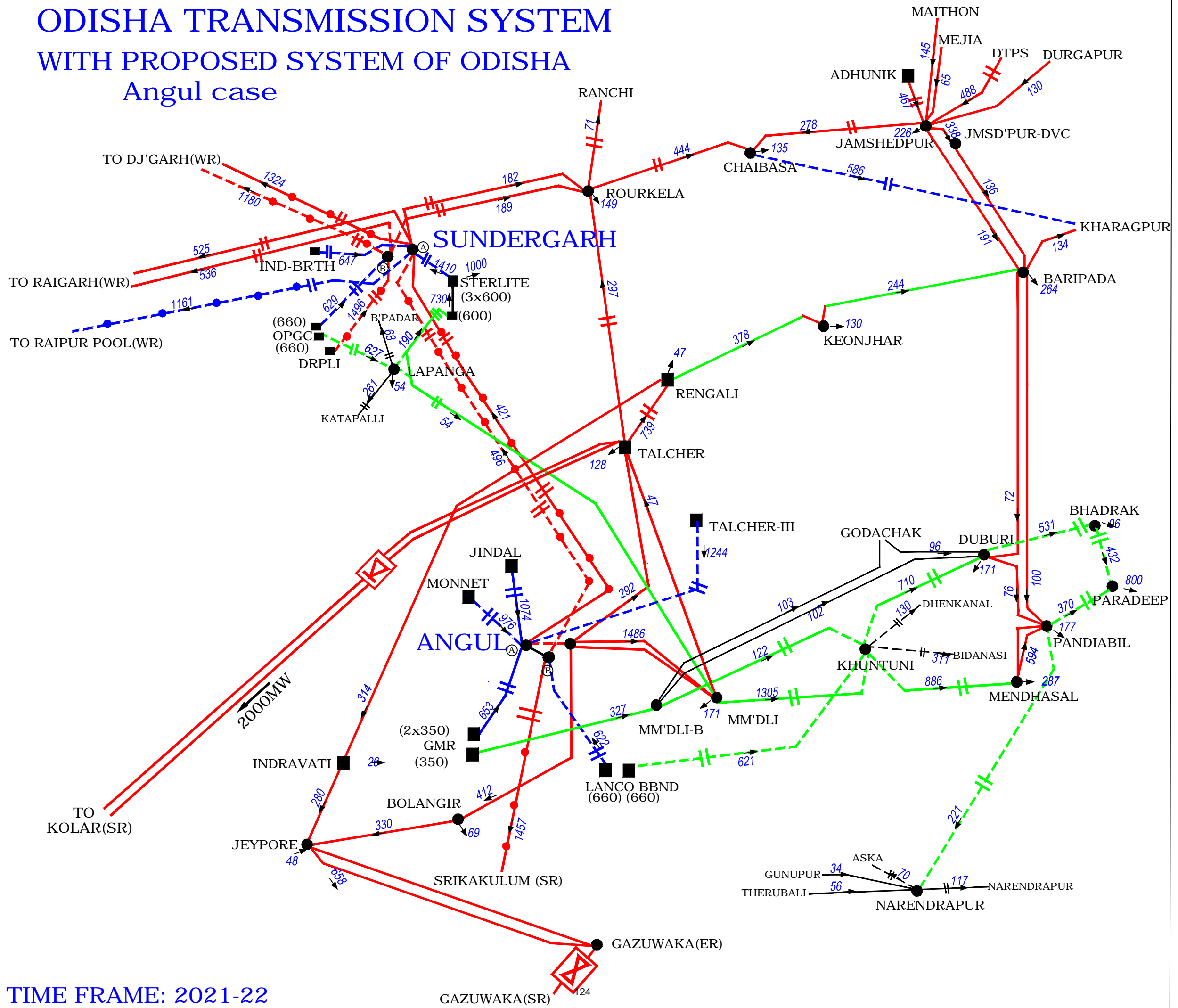

TIME FRAME: 2021-22

# ODISHA TRANSMISSION SYSTEM WITH PROPOSED SYSTEM OF ODISHA Angul case with Angul Bypass

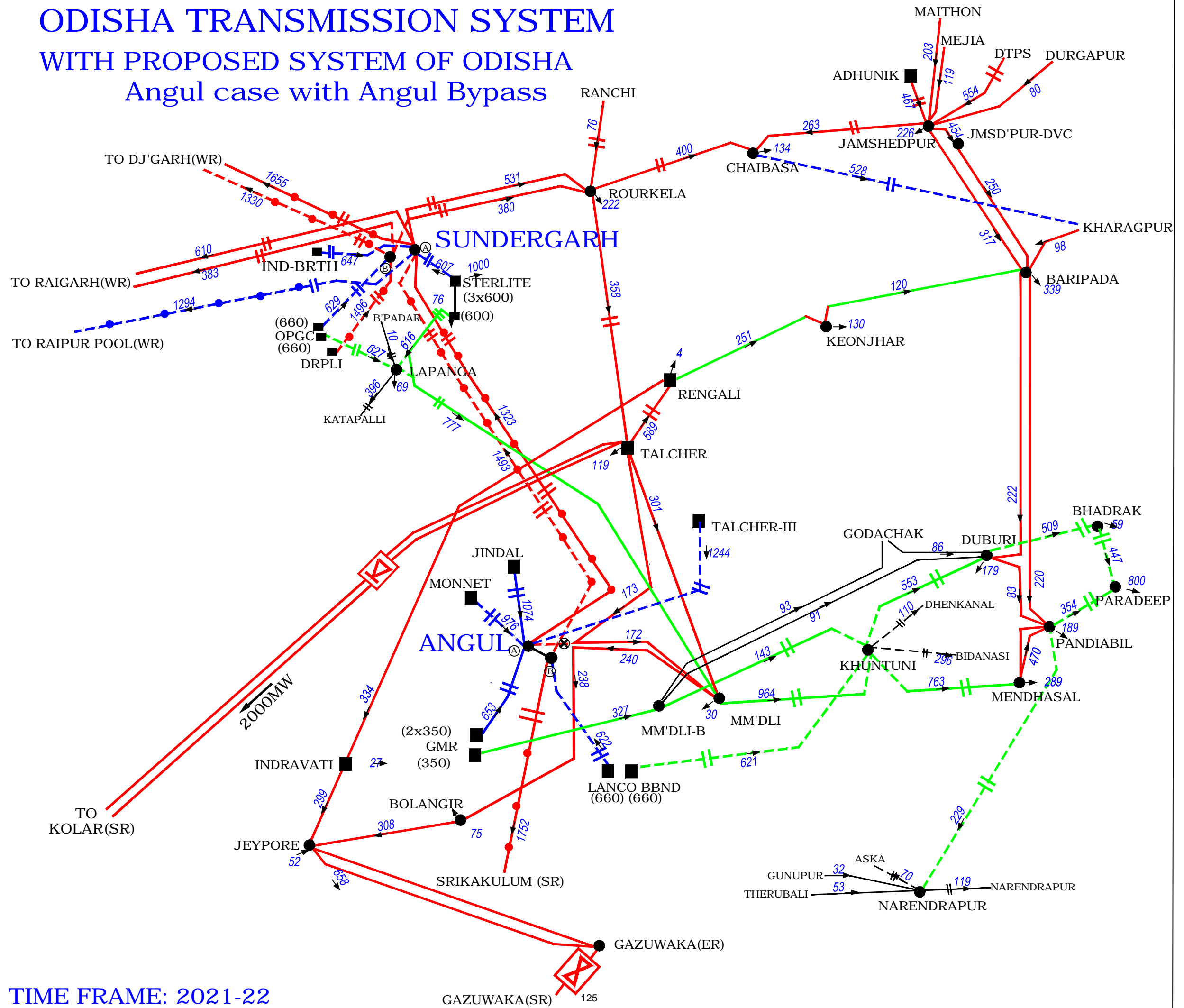

TIME FRAME: 2021-22

GAZUWAKA(SR) 125



# ODISHA TRANSMISSION SYSTEM WITH PROPOSED SYSTEM OF ODISHA Meramundali -B case

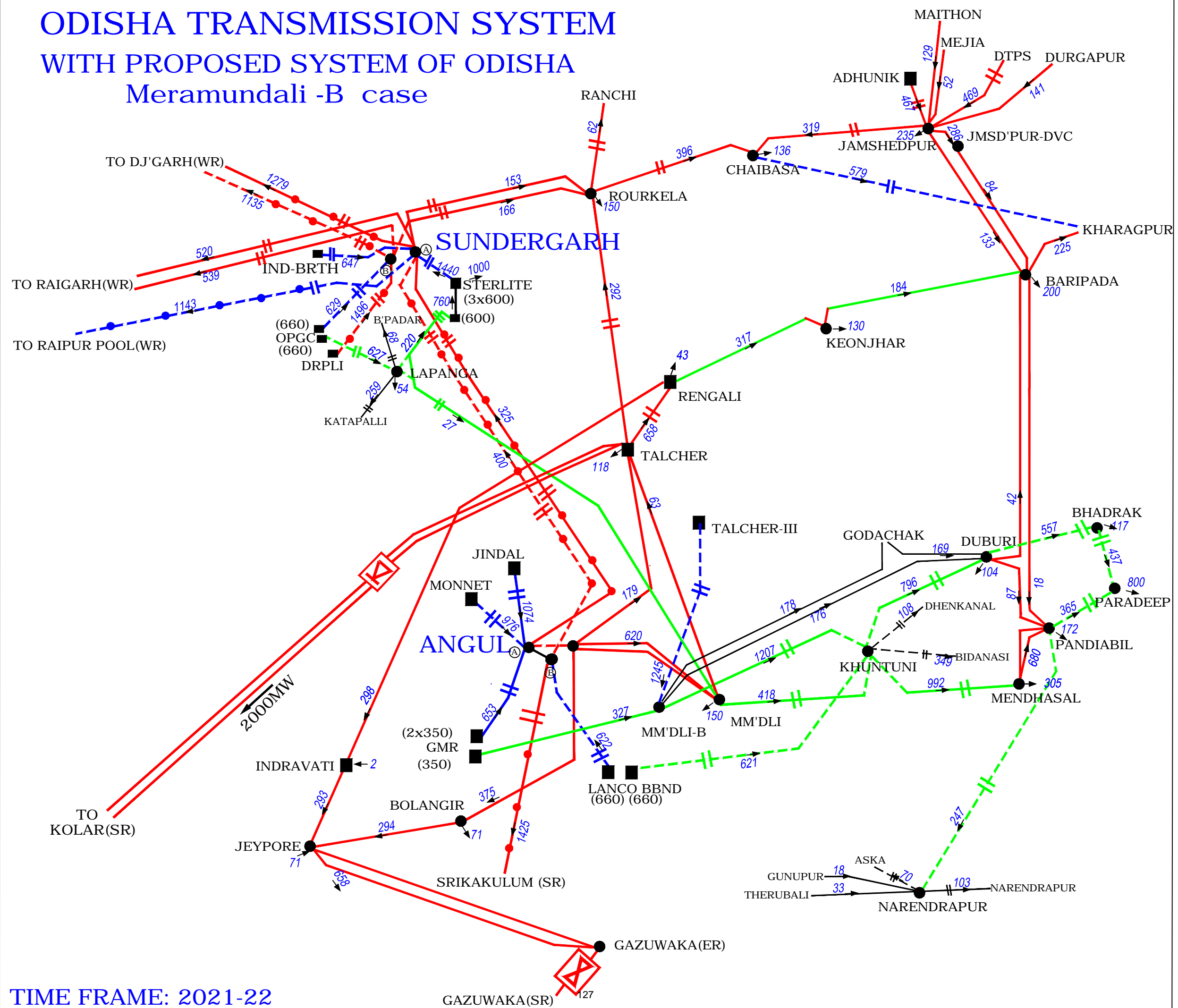

TIME FRAME: 2021-22

# ODISHA TRANSMISSION SYSTEM WITH PROPOSED SYSTEM OF ODISHA Meramundali-B case with Angul Bypass

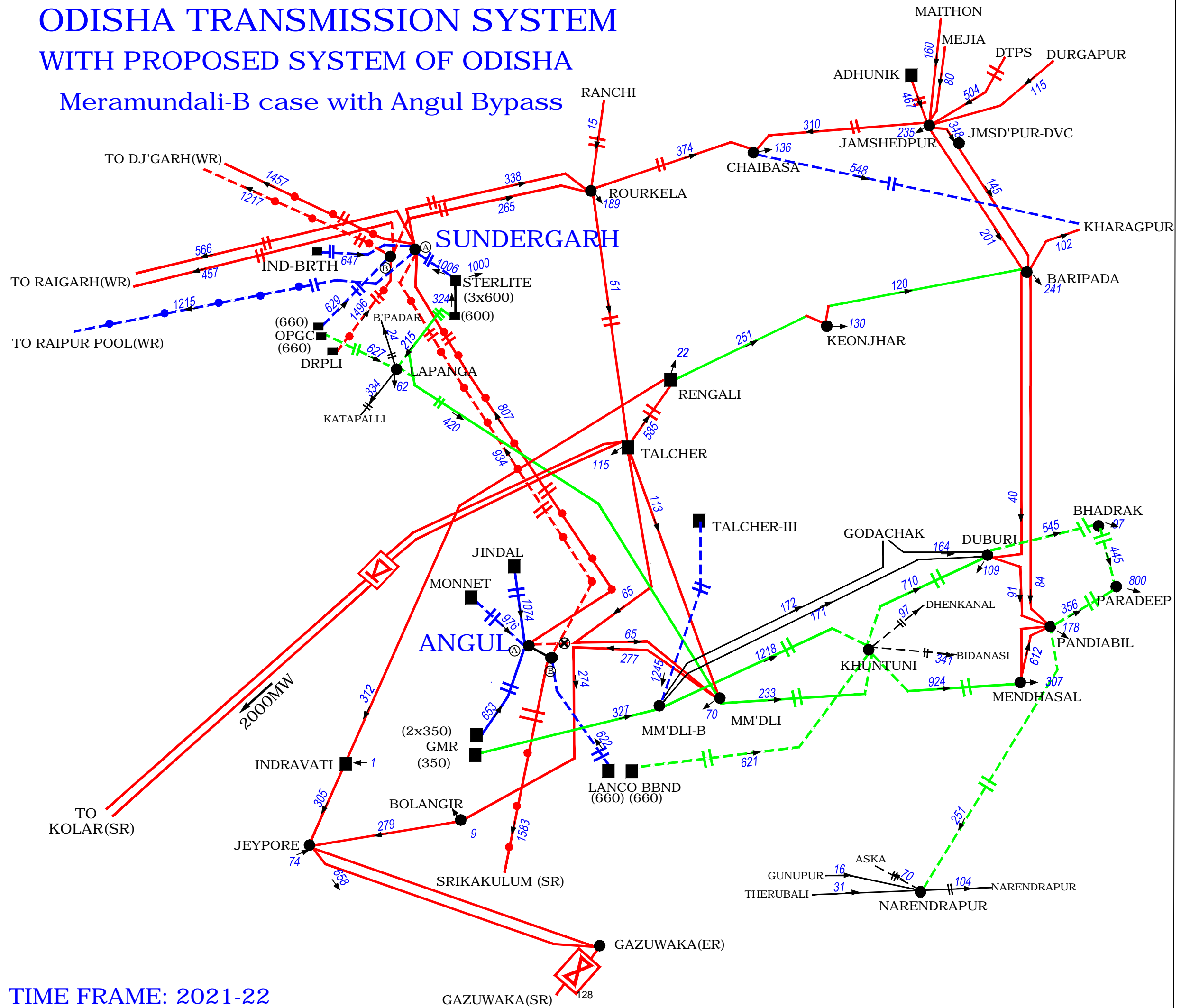

TIME FRAME: 2021-22



# ODISHA TRANSMISSION SYSTEM WITH PROPOSED SYSTEM OF ODISHA

Case B3

Meramundali-B case with Angul Bypass  
one LILO at Mera-B

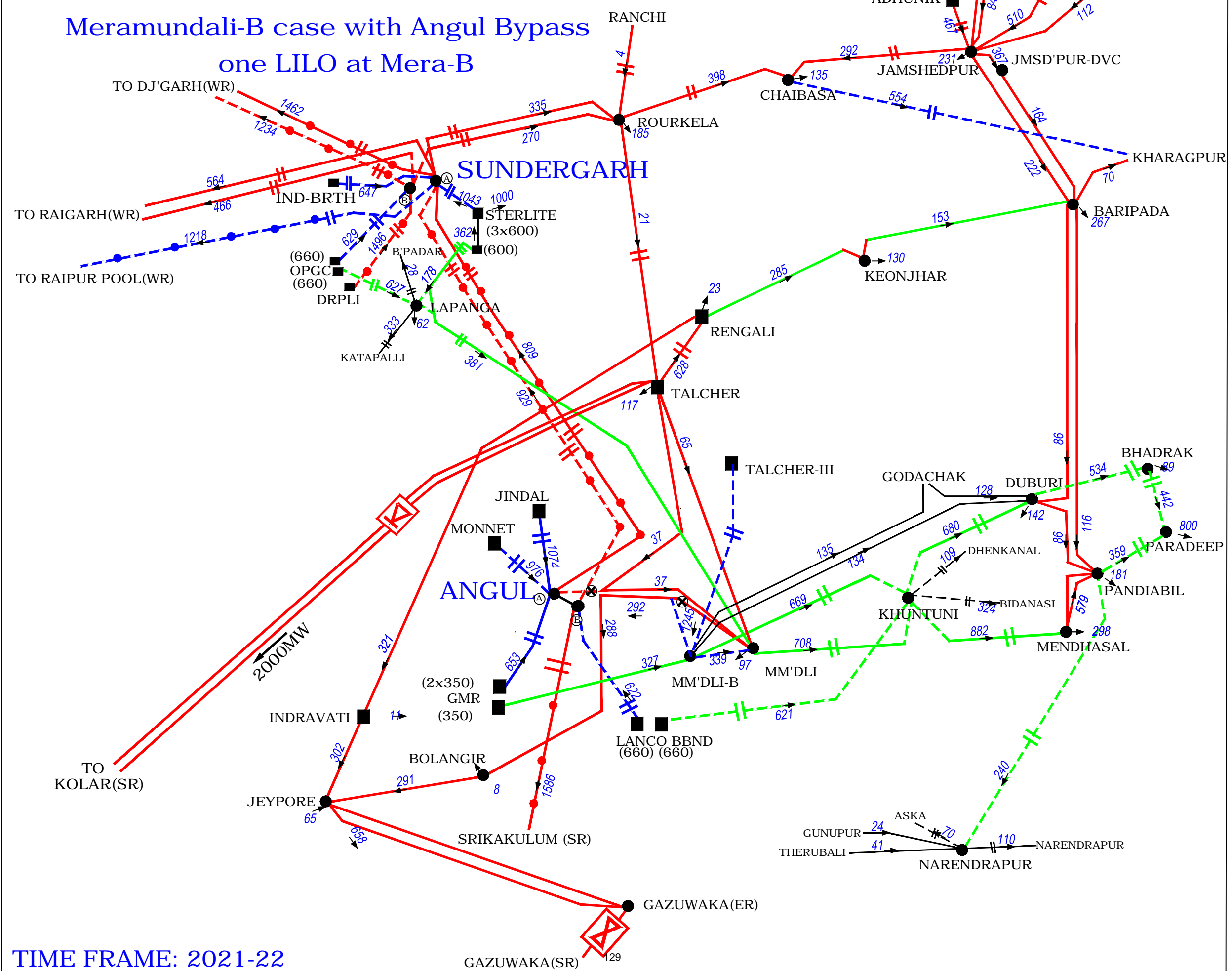

TIME FRAME: 2021-22

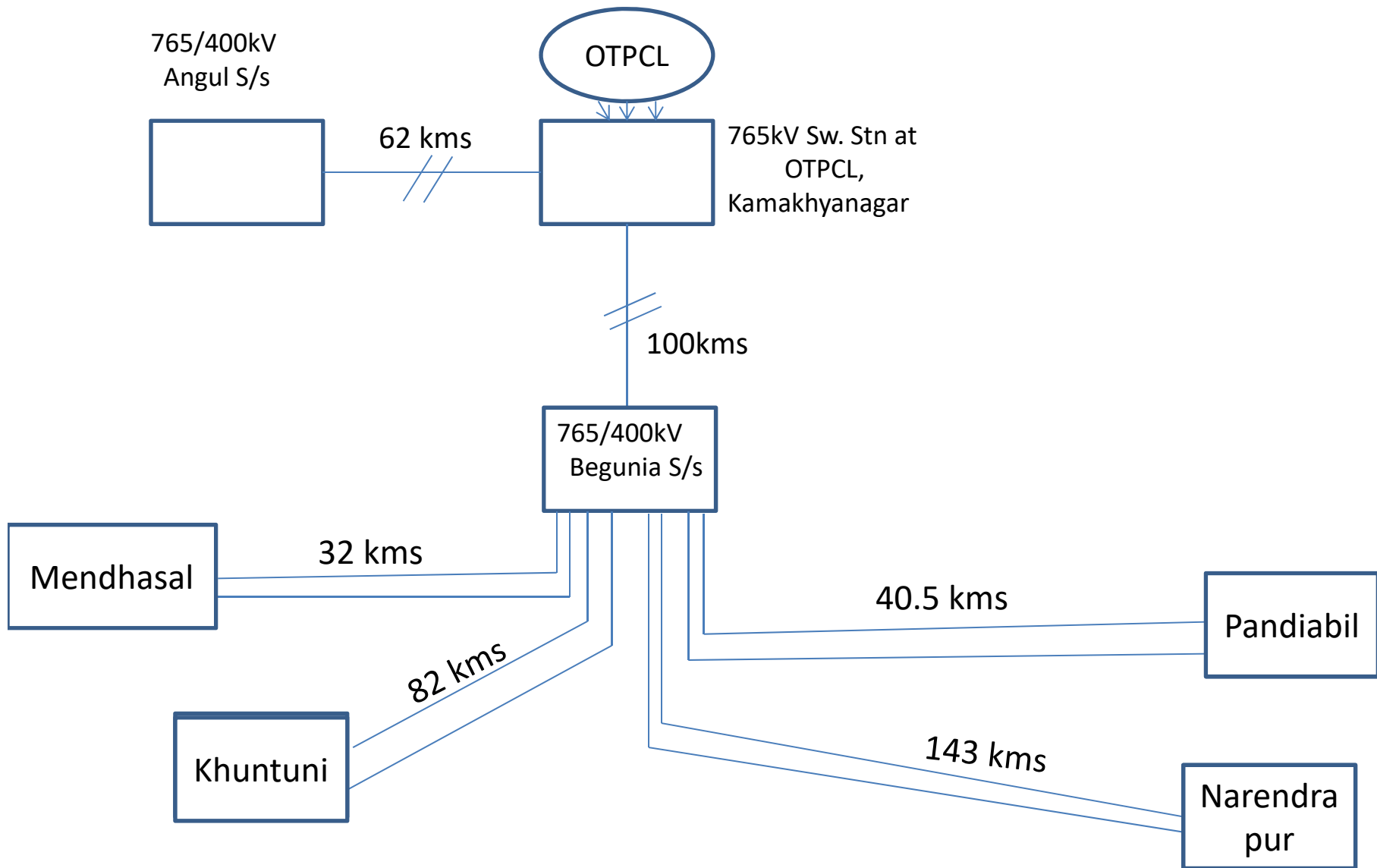

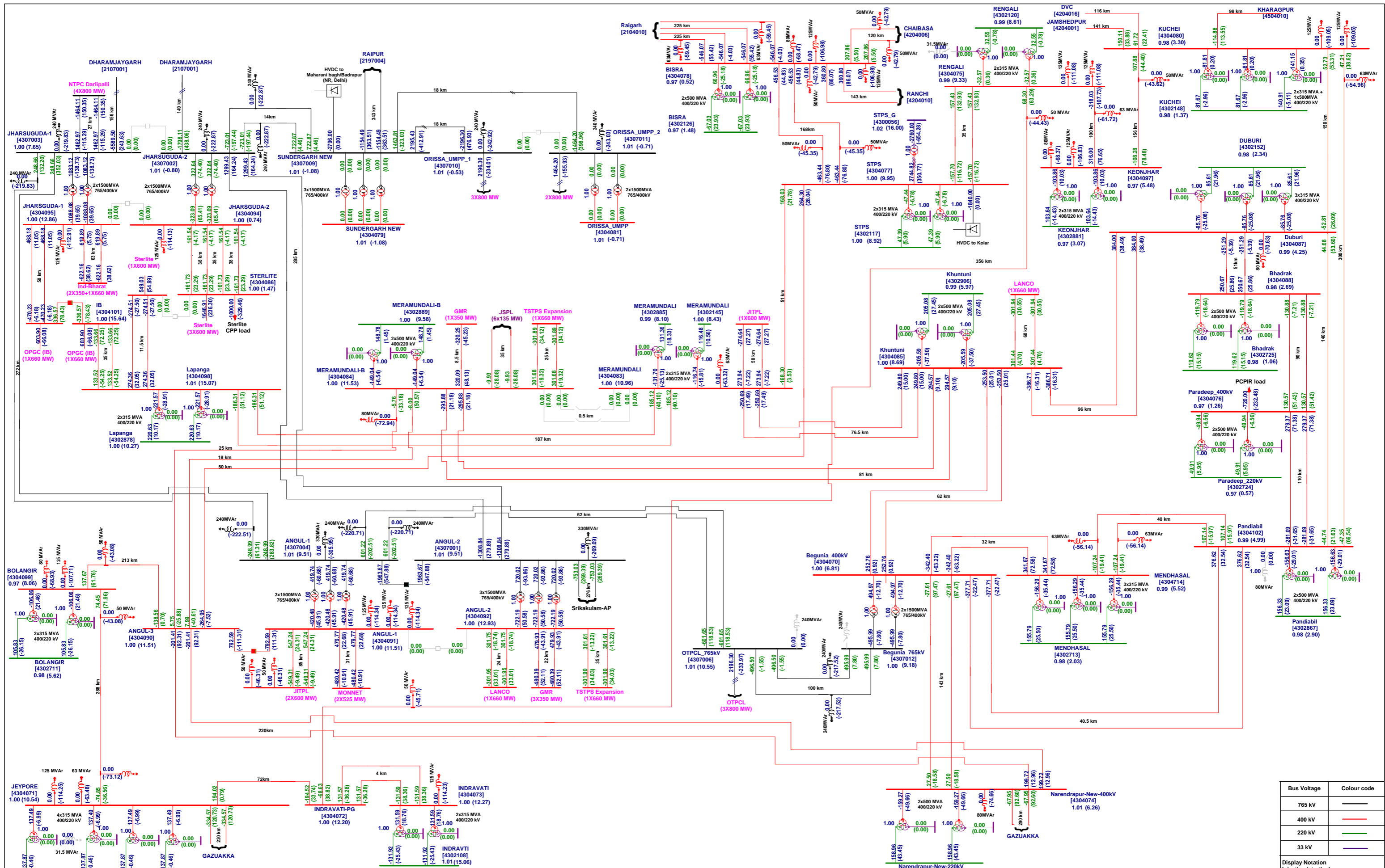

Bus Voltage	Colour code
765 kV	—
400 kV	—
220 kV	—
33 kV	—

Display Notation  
 Injection into the bus : +ve  
 Drawl away from the bus : -ve  
 Voltage Mag/(Ang) in PU /degree  
 Flows in MW and (Mvar)

APPROVED	REVIEWED	CHECKED	DRAWN	DESCRIPTION	REV	DATE:	REMARKS
					R3	09.02.2017	
					R2	21.07.2016	
				LFA	R1	26.04.2016	
					R0	18.12.2015	

Load Flow study results

Single line diagram of 765kV and 400kV transmission network - Odisha State 2021-22 condition

131

<p>Orissa Power Transmission Corporation Ltd.,                  Registered Office: Jampath,                  Bhubaneswar-751022                  Phone: (0674)-2541320/2542320</p>	<p>Power Research &amp; Development Consultants Pvt. Ltd.,                  #5, 11th Cross, 2nd Stage,                  West of Chord Road,                  Bangalore- 560086, INDIA                  Ph : +91-080-2319 2209,2159                  Fax: +91-080-2319 2210                  E-mail : prdc@prdc.com</p>	<p>PO details: CP-12/2015/10043(8)/jepc dated 17 October 2015.</p> <p>DRAWN IN : MiPower™ DWG. NO : LFA/2021-22/765-400kV-Basecase</p>
--	--	--

**Odisha Proposal with 765kV strengthening, Angul-Narendrapur-Gazuwaka, Talcher-III (2x660MW) and Kamakhyanagar (3x800MW)**

**A. Base case**

The base case has been prepared (with low hydro in southern Odisha) by-passing of 400kV LILOs of Talcher –Meramundali & Meramundali – Bolangir at Angul (to limit fault level of Meramundali) and with LILO of Meramundali – Angul/Bolangir at Meramundali-B (for even loading on Meramundali-Khuntuni and Meramundali-B – Khuntuni lines).

**B. Case A + Narendrapur – Theruvali – Jeypore 400kV D/c (Triple Snowbird)**

To strengthen the Gazuwaka HVDC system presently operating at 650MW to its full capacity of 1000MW, intrastate system of Narendrapur – Theruvali – Jeypore 400kV D/c (Triple Snowbird) has been studied. The power flow on this line is observed to be about 150MW. The fault level of Gazuwaka bus is about 4.8kA.

**B'. Case A + Angul – Narendrapur – Gazuwaka 400kV D/c (triple Snowbird)**

To strengthen the Gazuwaka HVDC system presently operating at 650MW to its full capacity of 1000MW, ISTS system of Angul – Narendrapur –Gazuwaka 400kV D/c (Triple Snowbird) has been studied. In this scenario, Narendrapur gets connected to two 400kV S/s for reliable supply of power. The power flow on Narendrapur - Gazuwaka is observed to be about 550MW. The fault level of Gazuwaka bus is about 7.4kA.

**C. Case B + Angul – Begunia 765kV D/c (Hexa Zebra)**

In the absence of 400kV LILOs of Talcher –Meramundali and Meramundali – Bolangir at Angul, major load centres of Odisha (Meramundali, Duburi, Pandiabil and Mendhasal) are fed through long lines from Lapanga and Baripada. To relieve the loading of these lines, Odisha's proposal of Angul – Begunia 765kV D/c line (via Kamakhyanagar - however without generation) has been studied. A new 2x1500MVA 765/400kV S/s has been created at Begunia with Angul – Begunia 765kV D/c line along with LILO of Pandiabil – Narendrapur 400kV D/c line and Khuntuni – Mendhasal 400kV D/c lines. About 1500MW of power flows from Angul to Begunia, out of which about 450-500MW flows to each Pandiabil and Mendhasal and about 600-650MW flows to Narendrapur. With this power

flow further increases on Narendrapur – Theruvali – Jeypore 400kV D/c line to about 300MW.

**D. Case C + Talcher-III System**

The evacuation system of Talcher-III is Talcher-III – Meramundali/ Meramundali-B 400kV D/c (triple Snowbird) line (one circuit terminated at Meramundali and other circuit terminated at Meramundali-B). In this case, there is no power evacuation problem from Talcher-III and loading on the corridors are within safe limits.

**E. Case D + 3x800MW Kamakhyanagar generation of Odisha**

Odisha is setting up 3x800MW generation at Kamakhyanagar. The evacuation system of Kamakhyanagar generation as proposed by Odisha is LILO of Angul – Begunia 765kV D/c line at generation switchyard. In this case, about 700MW of power flows towards Angul and about 1500MW flows towards Begunia. About 300MW power is observed to flow from Theruvali to Jeypore. The fault level of Gazuwaka is expected to be about 5.1kA.

**E'. Case E with Angul – Narendrapur – Gazuwaka system in place of Narendrapur – Theruvali – Jeypore**

As compared to case E, about 550MW power is observed to flow from Narendrapur to Gazuwaka. The fault level of Gazuwaka is expected to about 7.8kA (compared to 5.1kA in previous case).

**E''. Case E with Rourkela – Talcher – Behrampur – Gazuwaka system in place of Narendrapur – Theruvali – Jeypore**

In case the Reliance system revives, case E with Rourkela – Talcher – Behrampur – Gazuwaka 400kV has been studied. About 450MW power is expected to flow from Behrampur to Gazuwaka and the fault level of Gazuwaka is expected to about 6.7 kA.

**Fault Current (in kA)**

	Case A	Case B	Case B'	Case C	Case D	Case E	Case E'	Case E''
	Base case	Case A + Theruvali	Case A + Angul Gazuwaka	Case B + Angul Begunia	Case C + Talcher-III	Case D + kamakhyanagar	Case E + Angul Gazuwaka minus Theruvali	Case E + Talcher-Behrampur minus Theruvali
<b>400 kV</b>								
JEYPORE	6.8	8.7	9.1	9.5	9.6	9.7	9.5	8.9
JHARSUGUDA	40.5	40.5	40.5	40.6	40.7	40.9	40.9	41.1
ANGUL	38.6	38.6	42.1	41.0	41.2	43.7	46.2	43.6
BEGUNIA	-	-	-	27.0	28.0	29.3	30.9	28.3
MERAMUNDLI	26.9	27.0	28.6	31.3	37.3	37.6	38.2	38.3
MERAMNDLI-B	26.4	26.4	28.0	30.6	36.5	36.9	37.5	37.5
JHARSU-SPLI	47.8	47.8	47.9	47.8	48.2	48.6	48.6	48.7
GAZUWAKA-ER	4.2	4.8	7.4	5.0	5.1	5.1	7.8	6.7
TALCHER-III	-	-	-	-	30.9	31.1	31.5	31.5
NARENDRAPUR	6.2	8.4	13.8	11.3	11.5	11.6	16.4	9.2
<b>765 kV</b>								
ANGUL	26.8	26.8	27.9	30.4	30.7	35.0	35.3	34.9
JHARSUGUDA	36.9	36.9	37.1	37.4	37.5	38.2	38.3	38.3
BEGUNIA	-	-	-	16.7	17.0	19.2	19.2	18.9
KAMAKHYANAG	-	-	-	22.2	22.4	27.9	27.9	27.8
JHARSU-SPLI	29.3	29.3	29.4	29.7	29.8	30.5	30.5	30.5

# ODISHA TRANSMISSION SYSTEM

## WITH PROPOSED SYSTEM OF ODISHA

Base case

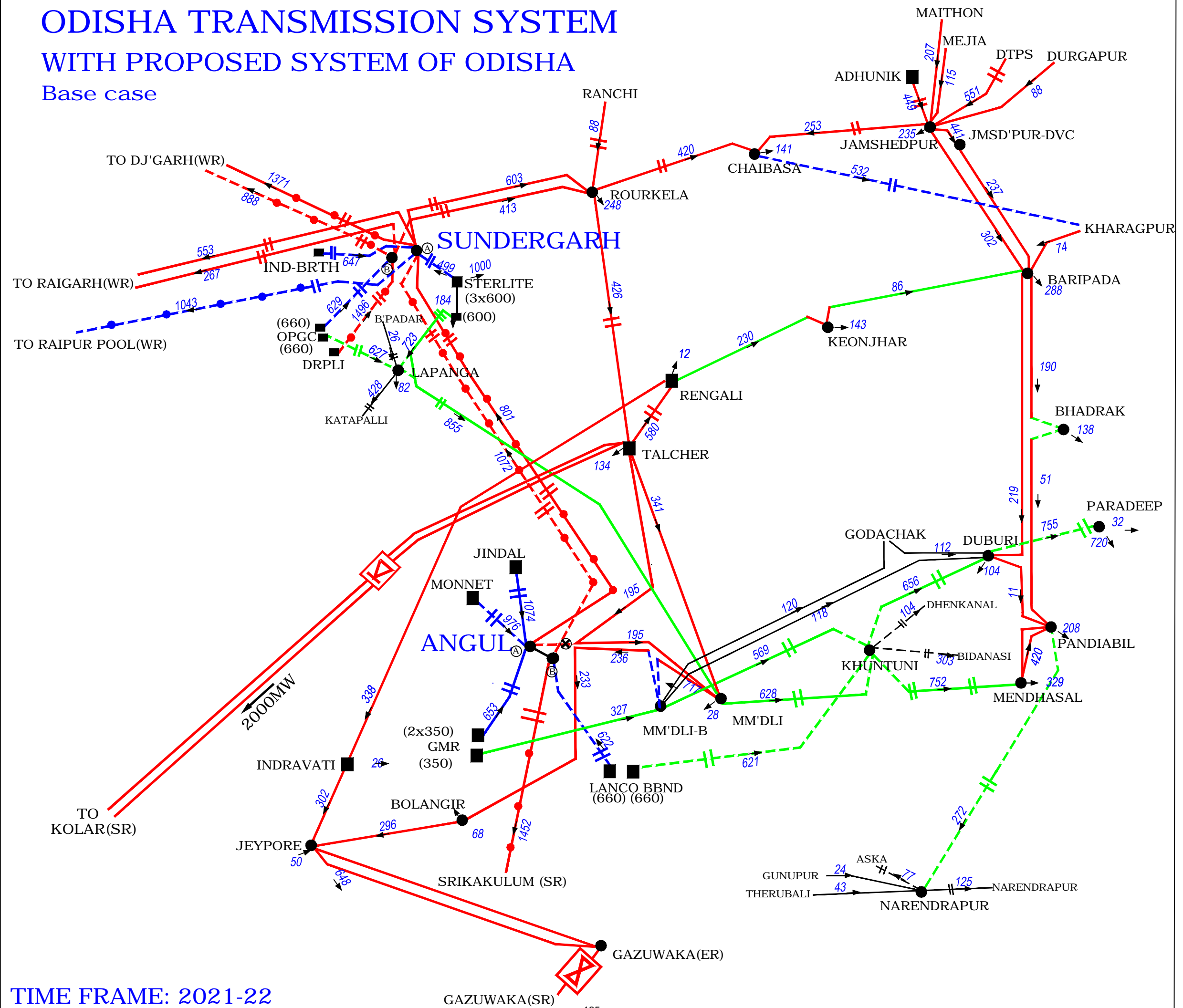

TIME FRAME: 2021-22

# ODISHA TRANSMISSION SYSTEM

## WITH PROPOSED SYSTEM OF ODISHA

Base case + Theruvali

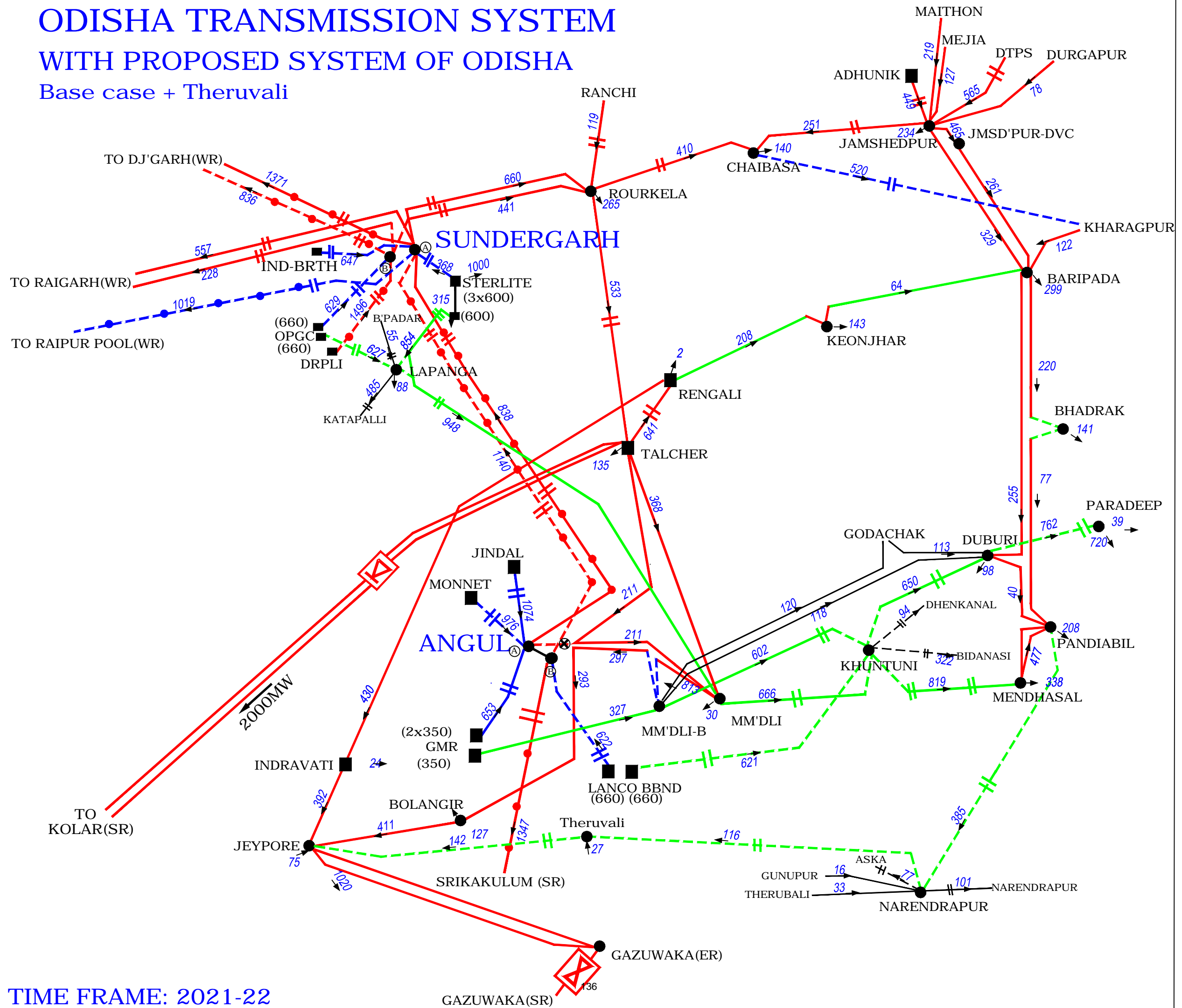

TIME FRAME: 2021-22



# ODISHA TRANSMISSION SYSTEM

## WITH PROPOSED SYSTEM OF ODISHA

Base case + Angul-Gazuwaka

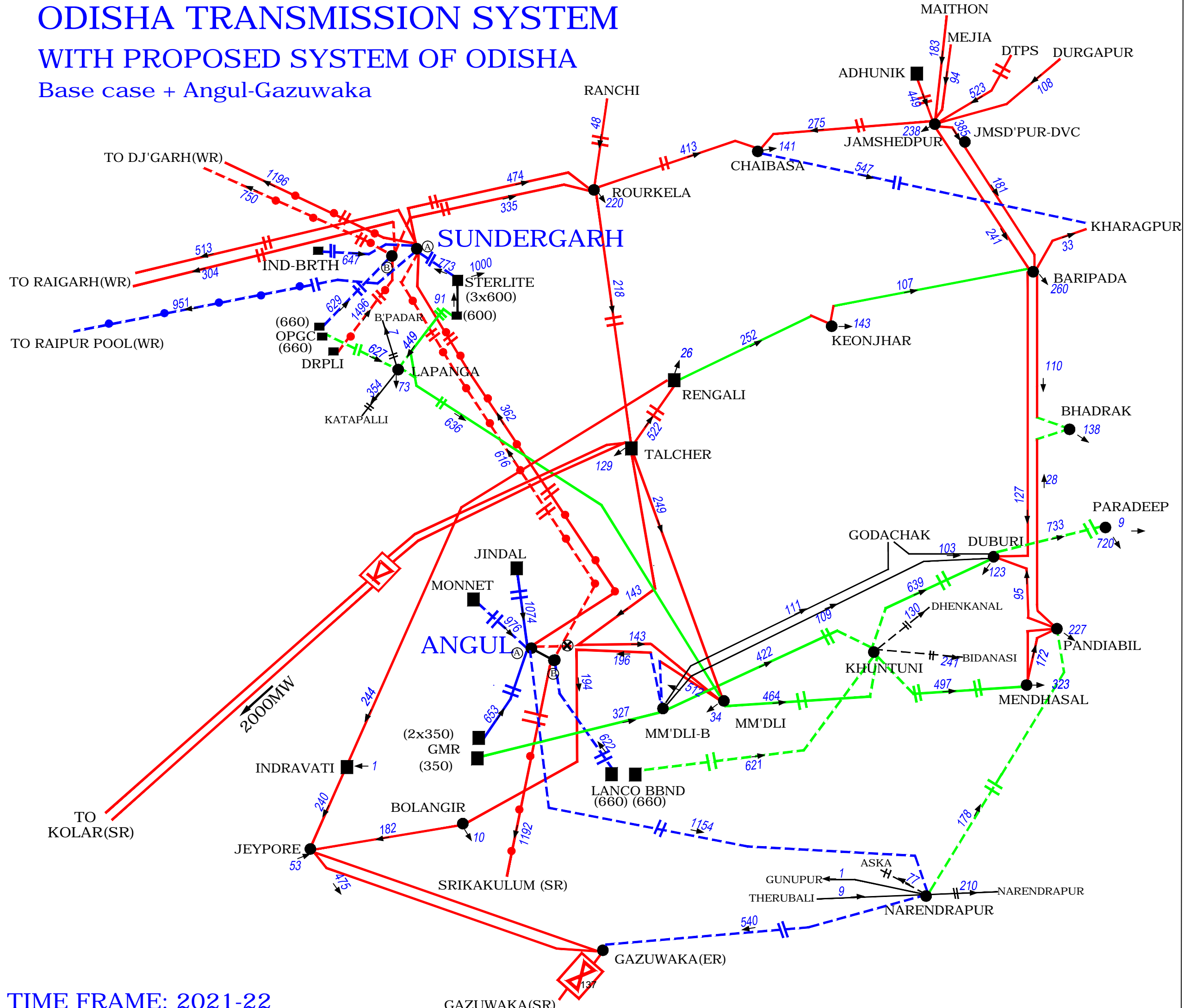

TIME FRAME: 2021-22

# ODISHA TRANSMISSION SYSTEM

## WITH PROPOSED SYSTEM OF ODISHA

Base case + Angul-Begunia + Theruvali

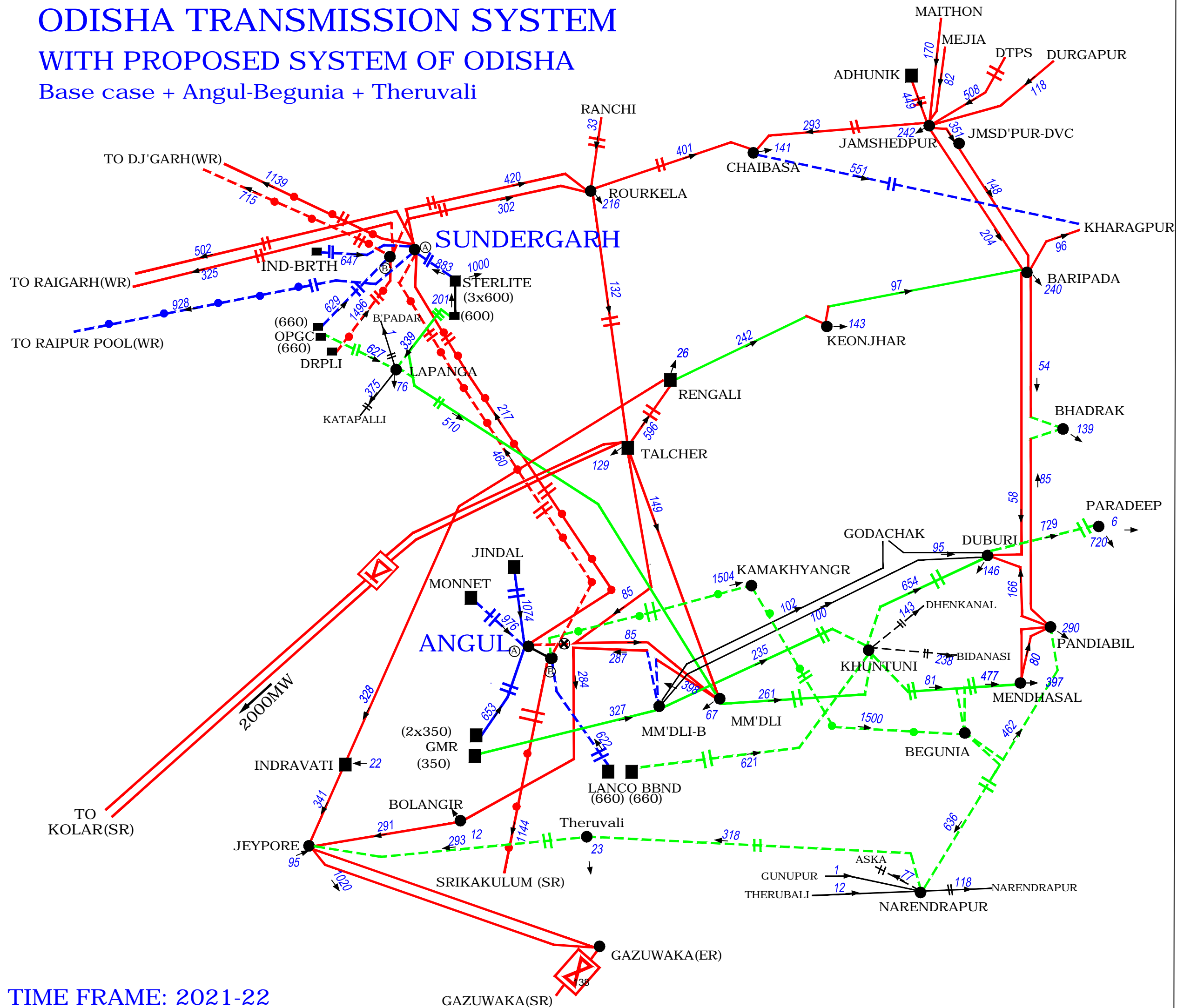

TIME FRAME: 2021-22

# ODISHA TRANSMISSION SYSTEM

## WITH PROPOSED SYSTEM OF ODISHA

Base case + Angul-Begunia + Talcher-III + Theruvali

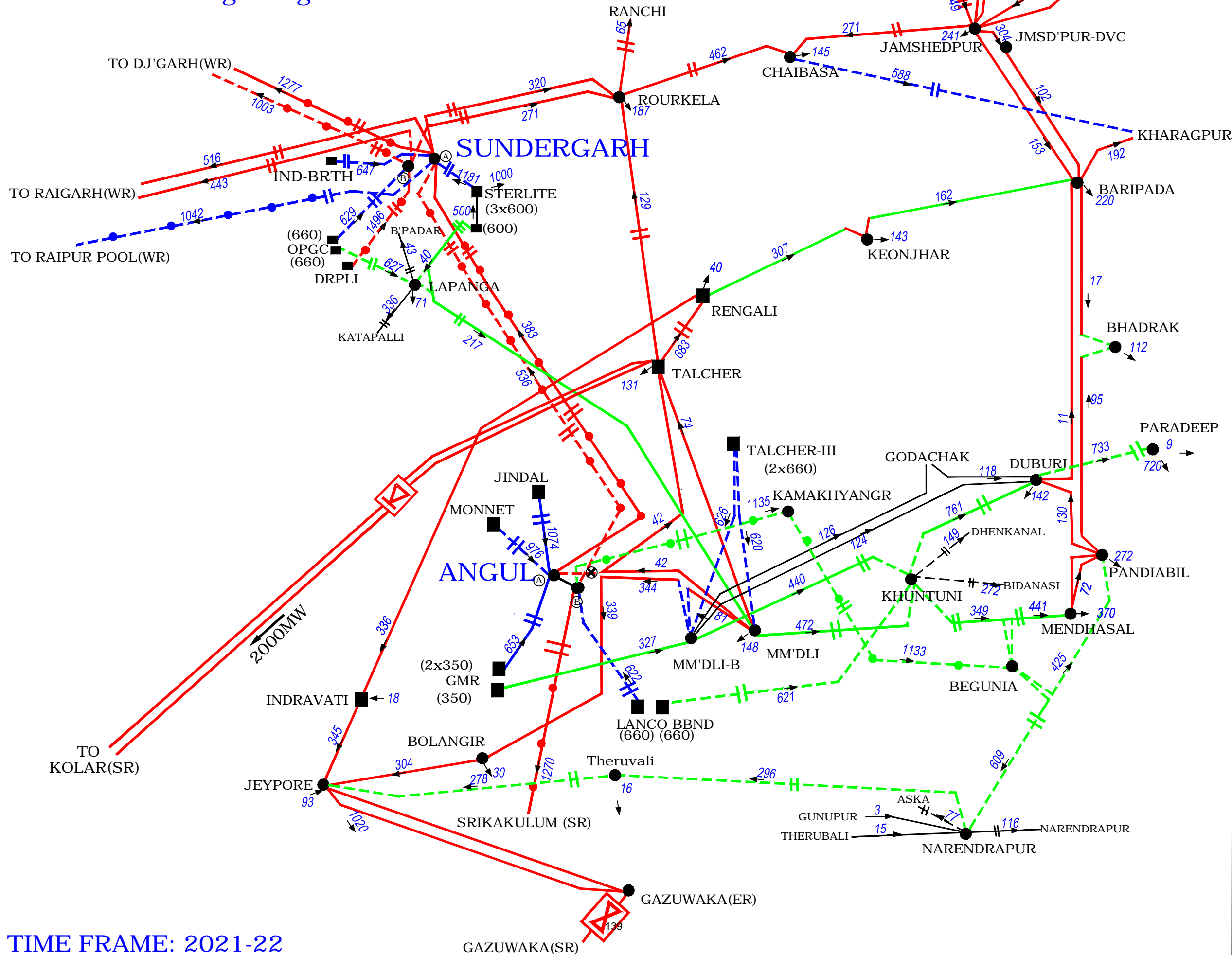

TIME FRAME: 2021-22

# ODISHA TRANSMISSION SYSTEM

## WITH PROPOSED SYSTEM OF ODISHA

Base case + Talcher-III + Angul - Begunia + Kamakhyangr + Theruvali

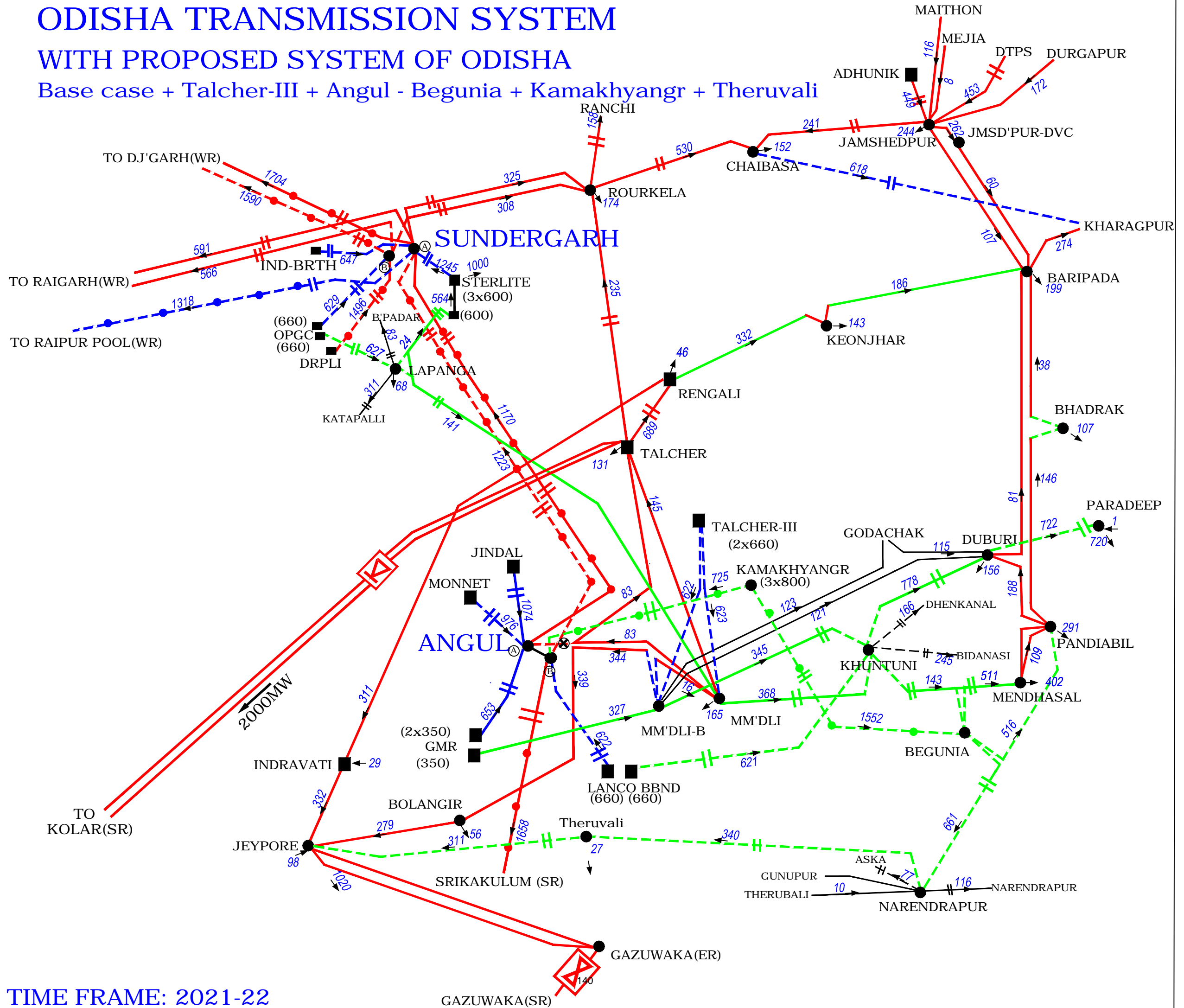

TIME FRAME: 2021-22

# ODISHA TRANSMISSION SYSTEM

## WITH PROPOSED SYSTEM OF ODISHA

Base case + Talcher-III + Angul - Begunia + Kamakhyangr + Angul - Gaz

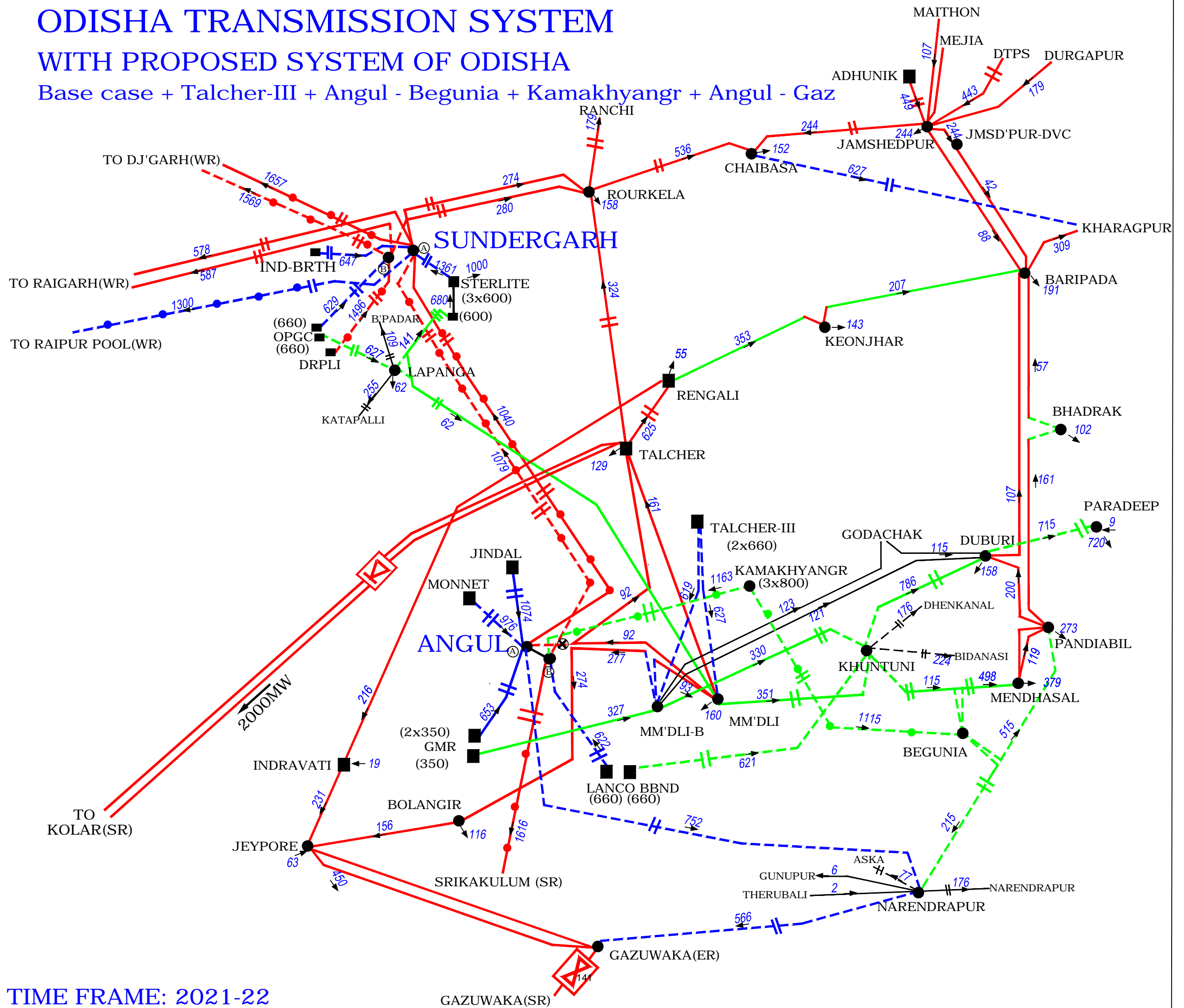

TIME FRAME: 2021-22

# ODISHA TRANSMISSION SYSTEM

## WITH PROPOSED SYSTEM OF ODISHA

Base case + Angul-Begunia + Kamakhyanagar + Talcher-III + Talcher-Gaz

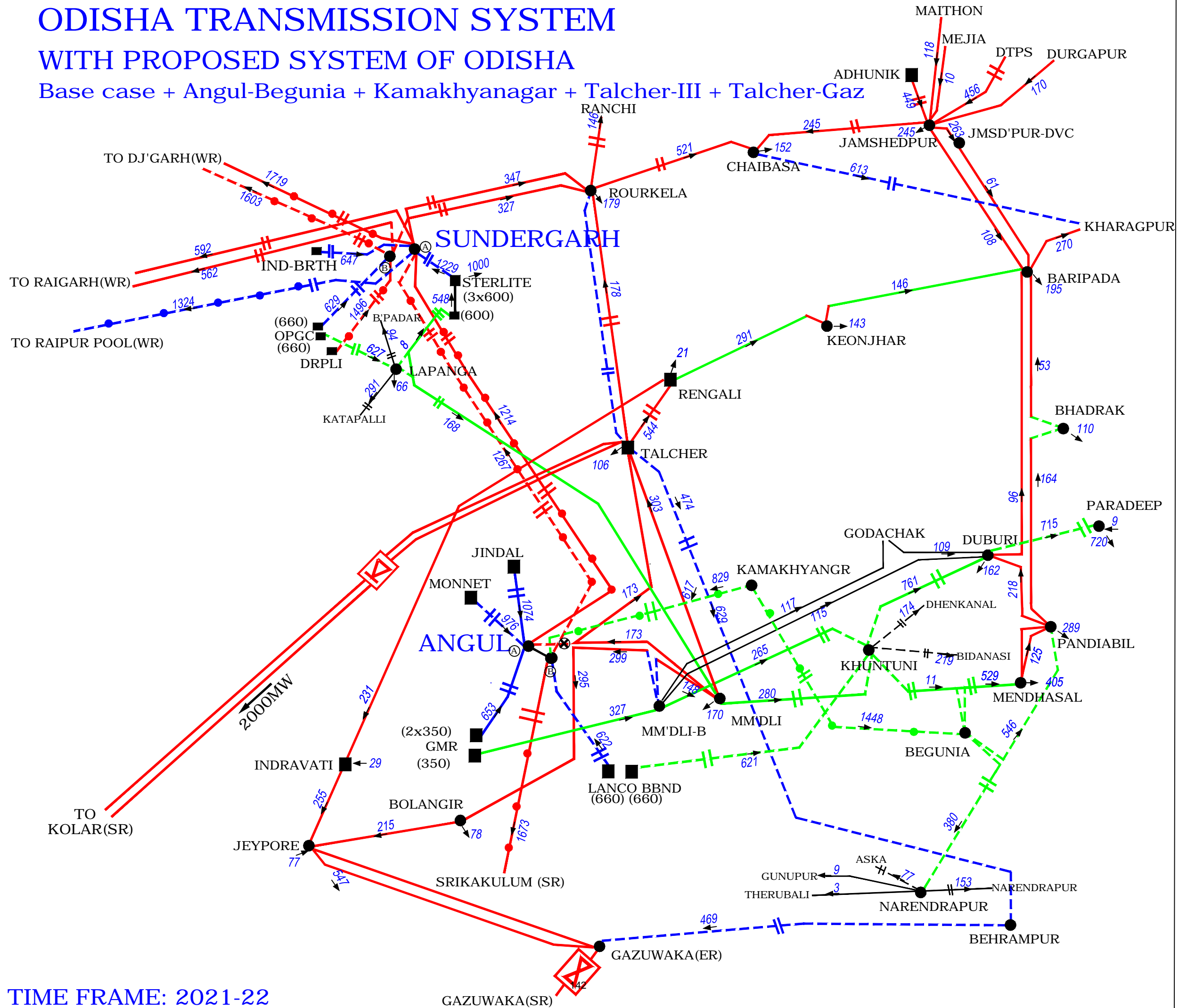

TIME FRAME: 2021-22