



**STANDARD TECHNICAL SPECIFICATION
FOR
MAIN PLANT PACKAGE
OF
SUB- CRITICAL THERMAL POWER PROJECT
2x (500 MW OR ABOVE)**

**Government of India
Ministry of Power
Central Electricity Authority
New Delhi**

SEPTEMBER, 2008



RAKESH NATH
Chairperson
Central Electricity Authority &
Ex-officio Secretary
Government of India

F O R E W O R D

An unprecedented growth is being witnessed by the power sector with a capacity addition of over 78,000 MW envisaged during 11th Plan and about 80,000 MW in 12th Plan. A programme of this magnitude requires that every possible opportunity for enhancing pace of capacity addition is explored and fully exploited. In this context, there has been a long felt need to standardize the technical specification of thermal power stations with a view to reducing the time for pre-award activities, design & engineering and the manufacturing by equipment manufacturers. Thus, a Committee was set up by CEA under the chairmanship of Member (Thermal) in May 2007 with participation from major utilities and manufacturers for developing standard technical specifications for main plant equipment for coal based thermal power plant having 500MW and higher capacity sub-critical units.

I would like to bring out here that the committee under Dr. Kirit S. Parikh, Member (Energy) Planning Commission has also recommended that CEA should finalize standard specifications covering scope of work, broad specifications and design criteria which should be flexible to attract wider participation of equipment suppliers and competition for main plant as well as balance of plant.

Several project specific factors like dimensions and orientation of land, quality of inputs, (cooling water, coal), location (coastal/non-coastal) soil & seismic conditions etc. make standardization of the entire plant difficult. Thus, the standardisation of main plant (Steam generator, turbine-generator and auxiliaries) was taken up as a first step. Having completed the same, the task to develop broad design criteria for balance of plant (BoP) i.e. coal handling plant (CHP), ash handling plant (AHP), water treatment system, etc. is being taken up in the next phase.

I am glad that the standard technical specification for Main Plant Package has been finalized by the Committee. The document reflects pooled experience and knowledge of participating engineers from CEA, utilities and main plant equipment manufacturers. I am sure that utilities as well as equipment manufacturers would find it useful in expediting the execution of thermal power projects having unit size of 500 MW or higher capacity.

New Delhi
September, 2008

(RAKESH NATH)



R. DAHIYA
Member (Thermal)
Central Electricity Authority &
Ex-officio Additional Secretary
Government of India

P R E F A C E

Standardisation is an established and important tool for faster execution of the projects in a cost effective manner. In the present power scenario, need of the hour is to ensure timely commissioning of a large capacity targeted in 11th and 12th Plans to meet the gap in the demand and supply of electricity in the country. Standardisation is expected to reduce the pre-award time and help in optimising manufacturing cycle thus leading to improved delivery schedules and reduction in overall cost.

I am glad that the Committee constituted by CEA in May 2007 having representation from major utilities and equipment manufacturers, has completed its task of finalizing standard technical specification for Main Plant Package for a coal based thermal power project having 2x (500MW or above) sub-critical units. The specification covers scope, design criteria, equipment features, quality assurance plans, performance guarantee tests, spares etc. and includes steam generator, turbine-generator alongwith auxiliaries and associated electrical, C&I and civil works.

Commercial and contract conditions have not been included in the document as utilities normally prefer to prescribe their own standard conditions. Also, site and project specific aspects viz. coal quality, cooling water source (river or sea), soil properties etc. which affect the design of main plant package have been indicated as foot notes so that utilities could incorporate the same in the bid document suitably.

I am sure that both utilities as well as equipment suppliers would find this document useful for adoption for their future projects.

I wish to express my appreciation and sincere thanks to all the members of the Committee from CEA, NTPC, BHEL, MAHAGENCO, APGENCO, WBPDC, REL, Tata Power and Alstom for sharing their experience and making valuable contribution in bringing out this document.

New Delhi
September, 2008

(R. DAHIYA)



**STANDARD TECHNICAL SPECIFICATION FOR MAIN
PLANT PACKAGE OF 2x(500MW OR ABOVE)
SUB- CRITICAL THERMAL POWER PROJECT**

MAIN CONTENTS

SECTION- 0	SITE SPECIFIC INFORMATION
SECTION- 1	GENERAL
SECTION- 2	STEAM GENERATOR AND AUXILIARIES
SECTION- 3	STEAM TURBINE AND AUXILIARIES
SECTION- 4	PIPING, VALVES, THERMAL INSULATION AND MISCELLANEOUS SYSTEMS/ EQUIPMENT
SECTION- 5	ELECTRICAL WORKS
SECTION- 6	CONTROL AND INSTRUMENTATION WORKS
SECTION- 7	CIVIL WORKS
SECTION- 8	QUALITY ASSURANCE PLAN
SECTION- 9	MANDATORY SPARES
DRAWINGS	



DETAILED CONTENTS

Clause No.	Description	Page No.
Section- 0 : Site Specific Information		
0.1	Project Name	0- 1
0.2	Location	0- 1
0.3	Climatological Data	0- 2
0.4	Fuel	0- 3
	0.4.1 Source of fuel	0- 3
	0.4.2 Coal and ash analysis	0- 3
	0.4.3 Secondary liquid fuels	0- 4
0.5	Water System	0- 5
0.6	Demineralised Water for Power Cycle Make-up	0- 5
Section- 1 : General		
1.1	Intent of Specification	1- 1
1.2	Scope of Supply	1- 3
	1.2.1 Steam generator and auxiliaries	1- 3
	1.2.2 Steam turbine and auxiliaries	1- 17
	1.2.3 High pressure/ power cycle piping, valves and miscellaneous systems/ equipments	1- 21
	1.2.4 Electrical works	1- 26
	1.2.5 Control and Instrumentation works	1- 28
	1.2.6 Civil works	1- 30
	1.2.7 Spares	1- 33
	1.2.8 Erection, commissioning and performance guarantee testing	1- 33
	1.2.9 Tools and tackles	1- 34
	1.2.10 Consumables, oils and lubricants	1- 35
1.3	Terminal Points and Exclusions	1- 36
	1.3.1 Terminal points	1- 36
	1.3.2 Exclusions	1- 37
1.4	General Technical Requirements	1- 38
1.5	Layout Considerations	1- 42
1.6	Performance Guarantees	1- 46
	1.6.1 General requirements	1- 46
	1.6.2 Guarantees under category- I	1- 47
	1.6.3 Guarantees under category- II	1- 52
	1.6.4 Guarantees under category- III	1- 52
	1.6.5 Performance guarantee/ acceptance test	1- 61
1.7	Spare Parts	1- 70
	1.7.1 Mandatory spares	1- 70
	1.7.2 Recommended spares	1- 70
	1.7.3 Start up and commissioning spares	1- 71
	1.7.4 General	1- 71
1.8	Testing, Inspection and Quality Assurance Plan	1- 73:76

Clause No.	Description	Page No.
Section- 2 : Steam Generator and Auxiliaries		
2.1	Design/ Sizing Criteria	2- 1
2.1.1	Type of steam generator	2- 1
2.1.2	Contractor's responsibilities	2- 1
2.1.3	Unit operation range	2- 1
2.1.4	Codes and standards	2- 1
2.1.5	Steam generator rating	2- 2
2.1.6	Fuels	2- 3
2.1.7	Cooling water	2- 6
2.1.8	Ambient air	2- 6
2.1.9	Limiting parameters for steam generator design	2- 7
2.1.10	Minimum load without oil support for flame stabilization	2- 7
2.1.11	Loading/ unloading pattern and adoptability for sudden load changes/ load throw off	2- 7
2.1.12	Operation without HP heaters in service	2- 8
2.1.13	Operation with/ without turbine HP-LP bypass system	2- 8
2.1.14	Mode of steam generation operation and rate of loading	2- 8
2.1.15	Provision for future installation of FGD system	2- 9
2.1.16	Furnace	2- 9
2.1.17	Pressure parts	2- 10
2.1.18	Superheaters and reheaters	2- 11
2.1.19	Economiser	2- 12
2.1.20	Air pre-heaters	2- 12
2.1.21	Steam coil air preheaters (SCAPH)	2- 13
2.1.22	Auxiliary steam PRDS	2- 13
2.1.23	Coal firing system	2- 14
2.1.24	Fuel oil preparation and firing system	2- 17
2.1.25	Draft plant	2- 18
2.1.26	Flue gas ducts and air ducts	2- 20
2.1.27	Electrostatic precipitator design data	2- 21
2.2	Technical Requirements	2- 24
2.2.1	Steam generator enclosure	2- 24
2.2.2	Super heaters and reheaters	2- 30
2.2.3	Economiser	2- 33
2.2.4	Air heaters and steam coil air preheaters	2- 35
2.2.5	Coal preparation and firing system	2- 38
2.2.6	Coal burners	2- 44
2.2.7	Primary air fans	2- 45
2.2.8	Balance draft system	2- 47
2.2.9	Fuel oil system	2- 50
2.2.10	Duct work and dampers	2- 57
2.2.11	Steam generator integral piping, valves, fittings and mountings	2- 64
2.2.12	Soot blowing system	2- 66



Clause No.	Description	Page No.
2.2.13	Blow down tanks (BDTs)	2- 68
2.2.14	Auxiliary steam pressure reducing and desuperheater stations (PRDS)	2- 69
2.2.15	Walk ways, platforms and stairs etc.	2- 70
2.2.16	Electrostatic precipitator	2- 72:78
Section- 3 : Steam Turbine and Auxiliaries		
3.1	Steam Turbine	3- 1
3.1.1	Equipment sizing criteria	3- 1
3.1.2	Type of steam turbine	3- 4
3.1.3	Turbine design and construction	3- 5
3.1.4	Steam admission valves (emergency stop, reheat stop, interceptor stop valves and control valves)	3- 8
3.1.5	Non return valves	3- 9
3.1.6	Insulation (steam turbine and BFP drive turbine)	3- 10
3.1.7	Material requirements	3- 10
3.1.8	Maintenance requirements	3- 11
3.1.9	Performance requirements	3- 12
3.2	Gland Sealing System for Steam Turbine & BFP Drive Turbine	3- 17
3.3	Turbine Lubrication Oil and Purification System	3- 18
3.4	Turbine Control Fluid System	3- 20
3.5	Turbine Governing System, Protective Devices and Unloading Gears	3- 21
3.5.1	Governing system	3- 21
3.5.2	Speed load changer	3- 21
3.5.3	Load limiting device	3- 21
3.5.4	Turbine protection devices	3- 22
3.5.5	Unloading gear	3- 22
3.5.6	Vacuum breaker	3- 23
3.6	Turbine Exhaust Hood Spray Control System	3- 24
3.7	Warming-up, Drain, Vent System and Flash Tanks	3- 25
3.8	HP-LP Steam Turbine Bypass System	3- 29
3.9	Steam Condensing Plant	3- 31
3.9.1	General requirements	3- 31
3.9.2	Condenser(s)	3- 32
3.9.3	Condenser air evacuation pumps	3- 37
3.9.4	Condensate extraction pumps	3- 38
3.9.5	Condenser on load tube cleaning system (COLTCS)	3- 42
3.9.6	Debris filter	3- 42
3.10	Feed Water Heating Plant	3- 44
3.10.1	Equipment sizing criteria	3- 44
3.10.2	General requirements	3- 45
3.10.3	LP heaters and drain cooler	3- 46
3.10.4	Deaerator	3- 47
3.10.5	HP heaters	3- 49



Clause No.	Description	Page No.
3.11	Boiler Feed Pumps	3- 50
3.11.1	Sizing criteria	3- 50
3.11.2	Design aspects	3- 51
3.11.3	Other requirements	3- 55
3.11.4	Mechanical seals	3- 56
3.11.5	Gear boxes	3- 57
3.11.6	Hydraulic coupling	3- 57
3.11.7	Other couplings	3- 58
3.11.8	Oil coolers	3- 58
3.11.9	Drive turbine	3- 59
3.11.10	Suction strainers	3- 63
3.12	Condensate Polishing Unit (CPU)	3- 64
3.12.1	Salient design data	3- 64
3.12.2	System requirements	3- 66
3.12.3	External regeneration facility	3- 69
3.12.4	Control and operation of plant	3- 72: 76
Section- 4 : Piping, Valves, Thermal Insulation and Miscellaneous Systems/ Equipment		
4.1	High Pressure/ Power Cycle Piping and Valves	4- 1
4.1.1	General	4- 1
4.1.2	Pipe sizing	4- 1
4.1.3	Material selection	4- 2
4.1.4	Pipe wall thickness	4- 2
4.1.5	Layout	4- 2
4.1.6	Stress/ dynamic analysis	4- 3
4.1.7	Piping	4- 3
4.1.8	Valves and specialties	4- 4
4.1.9	Fabrication requirements	4- 5
4.1.10	Erection requirements	4- 7
4.1.11	Piping and fittings	4- 7
4.1.12	Valves	4- 9
4.1.13	Hangers and supports	4- 10
4.1.14	Metallic expansion joints	4- 12
4.1.15	Chemical cleaning of piping systems and equipments	4- 14
4.1.16	Steam blowing of piping systems	4- 15
4.2	Control Valves	4- 18
4.2.1	General requirements	4- 18
4.2.2	Control valve sizing and construction	4- 18
4.2.3	Valve construction	4- 19
4.2.4	Valve materials	4- 19
4.2.5	End preparation	4- 20
4.2.6	Valve actuators	4- 20
4.2.7	Control valve accessory devices	4- 21
4.2.8	Tests	4- 21



Clause No.	Description	Page No.
4.3	Equipment Cooling Water (ECW) System	4- 22
4.3.1	General	4- 22
4.3.2	System design	4- 22
4.3.3	Constructional features	4- 23
4.3.4	Sizing/ design	4- 27
4.3.5	Over head DM make up tank	4- 27
4.3.6	Instruments	4- 28
4.4	Chemical Dosing System	4- 29
4.4.1	Low pressure chemical dosing	4- 29
4.4.2	High pressure chemical dosing (phosphate dosing)	4- 29
4.4.3	Control and instrumentation requirements	4- 30
4.5	Low Pressure Piping, Valves and Tanks	4- 31
4.5.1	LP piping- general	4- 31
4.5.2	Pipes and fittings	4- 32
4.5.3	Materials	4- 33
4.5.4	Piping layout	4- 34
4.5.5	Slope, drains and vents	4- 35
4.5.6	Pipe joints	4- 35
4.5.7	Joints for rubber lined pipes	4- 36
4.5.8	Bends/ elbows/ mitre bends/ tees/ reducers and other fittings	4- 37
4.5.9	Flanges	4- 37
4.5.10	Specific technical requirement of laying buried pipe with anti-corrosive treatment	4- 37
4.5.11	Cleaning and flushing	4- 39
4.5.12	Surface preparation and painting	4- 39
4.5.13	Specification for hangers and supports	4- 40
4.5.14	Design/ construction of gate/ globe/ check/ stop/ butterfly valves	4- 41
4.6	Thermal Insulation and Refractories	4- 46
4.6.1	General requirements	4- 46
4.6.2	Technical requirements	4- 47
4.6.3	Materials of insulation	4- 48
4.6.4	Refractories	4- 50
4.6.5	Application procedure for thermal insulation and refractories	4- 51
4.7	Main Plant EOT Crane	4- 58
4.7.1	Design requirements and constructional features	4- 58
4.7.2	Materials of construction	4- 61
4.7.3	Inspection and testing	4- 62
4.8	Elevators	4- 63
4.8.1	Scope of supply and services	4- 63
4.8.2	Design criterion	4- 64
4.8.3	Construction requirements	4- 65
4.8.4	Operational requirements	4- 65
4.8.5	Safety, inspection and testing	4- 66



Clause No.	Description	Page No.
4.9	Air Conditioning System	4- 67
4.9.1	General description	4- 67
4.9.2	Design philosophy	4- 67
4.9.3	Redundancy of equipments	4- 70
4.9.4	Equipment description	4- 70
4.9.5	Balance equipment specification	4- 75
4.9.6	Low pressure air distribution system	4- 78
4.9.7	Diffusers, grills and dampers	4- 79
4.9.8	Electrical works	4- 80
4.9.9	Thermal and acoustic insulation	4- 80
4.9.10	Plant control	4- 84
4.9.11	Painting	4- 86
4.9.12	Codes and standards	4- 87
4.9.13	Shop tests	4- 87
4.9.14	Site tests	4- 87
4.10	Ventilation System	4- 88
4.10.1	General description	4- 88
4.10.2	Design philosophy	4- 88
4.10.3	Redundancy of equipments	4- 90
4.10.4	Equipment description	4- 91
4.10.5	Balance equipment specification	4- 94
4.10.6	Low pressure air distribution system	4- 96
4.10.7	Diffusers, grills and dampers	4- 96
4.10.8	Electrical works	4- 97
4.10.9	Thermal and acoustic insulation	4- 97
4.10.10	Plant control	4- 97
4.10.11	Painting	4- 98
4.10.12	Codes and standards	4- 99
4.10.13	Shop tests	4- 99
4.10.14	Site tests	4- 99
4.11	Vibration Isolation Spring Foundations	4- 100
4.11.1	General requirement	4- 100
4.11.2	Material (design and supply)	4- 100
4.11.3	Manufacturing and testing	4- 101
4.11.4	Erection, commissioning and supervision	4- 101
4.11.5	Realignment of spring system	4- 101
4.11.6	Acceptance criteria	4- 101
4.11.7	Codes and standards	4- 101: 102
Section- 5 : Electrical Works		
5.1	Generator	5- 1
5.1.1	Type	5- 1
5.1.2	Rating	5- 1
5.1.3	System of cooling	5- 2



Clause No.	Description	Page No.
5.1.4	Insulation	5- 2
5.1.5	Temperature limits	5- 2
5.1.6	Operational requirements	5- 3
5.1.7	Design and constructional features	5- 4
5.1.8	Transportation	5- 11
5.2	Generator Auxiliary Systems	5- 12
5.2.1	Gas system	5- 12
5.2.2	Seal oil system	5- 14
5.2.3	Stator water cooling system	5- 16
5.2.4	Generator excitation system	5- 19
5.3	Generator Isolated phase Busducts (IPBD) and Neutral Grounding Equipment	5- 28
5.3.1	Codes and standards	5- 28
5.3.2	General technical requirements	5- 28
5.3.3	Equipment description	5- 29
5.3.4	Temperature rise	5- 32
5.3.5	Enclosure	5- 32
5.3.6	Bus conductor	5- 32
5.3.7	Insulators	5- 32
5.3.8	Connections and terminations	5- 33
5.3.9	Grounding	5- 33
5.3.10	Supporting structure	5- 33
5.3.11	Air pressuring	5- 34
5.3.12	Current transformers (CTs)	5- 34
5.3.13	Voltage transformer and surge protection (SP) cubicles	5- 35
5.3.14	Neutral grounding (NG) cubicle	5- 35
5.3.15	Cubicle construction (VT SP and NG cubical etc.)	5- 35
5.3.16	Space heaters, Illumination and grounding	5- 36
5.3.17	Finish	5- 36
5.4	Power Transformers	5- 37
5.4.1	Codes and standards	5- 37
5.4.2	General technical requirements	5- 37
5.4.3	Specific technical requirements	5- 37
5.4.4	Design requirements	5- 41
5.4.5	Noise level	5- 41
5.4.6	Insulation level	5- 42
5.4.7	Other requirements	5- 42
5.4.8	Transformer transportation	5- 42
5.4.9	Fittings for main and OLTC tank	5- 42
5.4.10	Transformer oil centrifuging plant	5- 43
5.5	11kV & 3.3kV Segregated Phase Busducts	5- 45
5.5.1	Code & standards	5- 45
5.5.2	General technical requirements	5- 45



Clause No.	Description	Page No.
5.5.3	Equipment description	5- 47
5.6	Auxiliary Service Transformer	5- 49
5.6.1	Codes and standards	5- 49
5.6.2	Technical parameters	5- 49
5.6.3	Neutral grounding resistor	5- 51
5.6.4	Performance	5- 52
5.6.5	Painting of tank, conservator, radiator and accessories	5- 52
5.6.6	Detailed description	5- 53
5.6.7	Transformer cooling system	5- 56
5.6.8	Terminal arrangement	5- 56
5.6.9	Current transformer	5- 57
5.6.10	Marshalling box	5- 57
5.6.11	Off circuit tap changing gear (OCTC)	5- 57
5.6.12	Fittings	5- 58
5.7	Motors	5- 59
5.7.1	Codes and standards	5- 59
5.7.2	General requirements	5- 59
5.7.3	Types	5- 60
5.7.4	Ratings	5- 60
5.7.5	Temperature rise	5- 60
5.7.6	Operational requirements	5- 60
5.7.7	Design and constructional features	5- 61
5.8	11kV & 3.3kV Switchgears	5- 63
5.8.1	Codes and standards	5- 63
5.8.2	Technical parameters	5- 64
5.8.3	Bus transfer scheme	5- 68
5.8.4	Metering	5- 68
5.8.5	General technical requirements	5- 68
5.8.6	Spare feeders	5- 82
5.9	415V Switchgear and Non-segregated Phase Busduct, DC Boards	5- 83
5.9.1	Codes and standards	5- 83
5.9.2	Technical parameters	5- 84
5.9.3	Automatic reserve closure	5- 84
5.9.4	Emergency PMCC	5- 84
5.9.5	Metering	5- 85
5.9.6	General technical particulars	5- 85
5.9.7	Protection	5- 90
5.9.8	Design and constructional features	5- 90
5.9.9	Spare feeders	5- 92
5.9.10	415V Non-segregated phase busduct	5- 92
5.10	Power and Control Cables	5- 94
5.10.1	Codes and standards	5- 94
5.10.2	Design criteria	5- 95



Clause No.	Description	Page No.
5.10.3	General technical requirements	5- 96
5.10.4	Constructional requirements	5- 97
5.10.5	Identification of cores	5- 99
5.10.6	Arrangement of cables	5- 99
5.10.7	Drum lengths	5- 99
5.11	Installation of Cables, Earthing System and Lightning Protection System	5- 100
5.11.1	Codes and standards	5- 100
5.11.2	Design and constructional features	5- 101
5.11.3	Equipment description	5- 101
5.11.4	Installation	5- 105
5.11.5	Earthing system	5- 110
5.11.6	Lightning protection system	5- 112
5.12	DC Storage Battery	5- 114
5.12.1	Codes and standards	5- 114
5.12.2	Technical particulars	5- 114
5.12.3	General technical requirements	5- 115
5.13	Battery Charger	5- 121
5.13.1	Codes and standards	5- 121
5.13.2	Technical particulars	5- 121
5.13.3	Interlocks	5- 121
5.13.4	General technical particulars	5- 122
5.14	Control Metering and Protections	5- 129
5.14.1	Codes and standards	5- 129
5.14.2	Control requirements	5- 129
5.14.3	Metering	5- 130
5.14.4	Protection and relay panels	5- 131
5.14.5	Generator disturbance recorder (DR)	5- 136
5.14.6	Electrical control board	5- 137
5.14.7	Relay test kit for generator protection	5- 138
5.15	Electrical Laboratory and Testing Equipments	5- 139
5.15.1	Auxiliary power supplies	5- 139
5.15.2	List of minimum requirements	5- 139
5.16	Emergency Diesel Generating Sets	5- 154
5.16.1	Codes and standards	5- 154
5.16.2	Design requirements and sizing criteria	5- 154
5.16.3	Installation	5- 155
5.16.4	Critical speed	5- 155
5.16.5	General technical requirements	5- 156
5.16.6	Diesel engine	5- 157
5.16.7	Generator	5- 159
5.16.8	Excitation system	5- 160
5.16.9	Automatic voltage regulator (AVR)	5- 160



Clause No.	Description	Page No.
5.16.10	Protection	5- 161
5.16.11	Metering	5- 161
5.16.12	Diesel generator control panel	5- 161
5.16.13	Sound proofing system	5- 162
5.17	Electrostatic Precipitators	5- 164
5.17.1	General	5- 164
5.17.2	Transformer rectifier (TR) sets	5- 164
5.17.3	ESP insulators	5- 166
5.17.4	ESP earthing, shielding and safety methods	5- 166
5.17.5	ESP control system	5- 167: 170
Section- 6 : Control and Instrumentation Works		
6.1	General Requirements	6- 1
6.1.1	General requirements	6- 1
6.1.2	Reliability and availability	6- 1
6.1.3	Standardisation and uniformity of hardware	6- 2
6.1.4	Operability and maintainability	6- 2
6.1.5	Unit control and monitoring philosophy	6- 3
6.1.6	Environmental conditions	6- 4
6.2	Distributed Digital Control, Monitoring and Information System (DDCMIS)	6- 6
6.2.1	General requirements	6- 6
6.2.2	System description	6- 9
6.2.3	Measurement functions of control system	6- 11
6.2.4	Control system requirements	6- 15
6.2.5	Man-machine interface system and plant information system (MMIPIS) requirements	6- 28
6.2.6	Program development/ modification, system maintenance and documentation facility	6- 34
6.2.7	Data communication system (DCS)	6- 36
6.2.8	Sequence of events recording/ annunciation functions	6- 37
6.2.9	Master & slave clock system	6- 38
6.2.10	Power supply & grounding	6- 38
6.2.11	System software requirements	6- 39
6.2.12	System documentation	6- 39
6.2.13	Training	6- 40
6.2.14	Warranty	6- 40
6.2.15	Performance requirement of the DDCMIS	6- 41
6.2.16	Large video screen (LVS)	6- 45
6.3	Other SG/TG Related Control & Instrumentation System/ Equipments	6- 48
6.3.1	Flame monitoring system	6- 48
6.3.2	Coal feeders control and instrumentation	6- 49
6.3.3	Electromatic safety valves	6- 50



Clause No.	Description	Page No.
6.3.4	Furnace temperature probes	6- 50
6.3.5	Acoustic pyrometer	6- 50
6.3.6	Mill and air heater fire detection system	6- 51
6.3.7	Furnace and flame viewing system	6- 51
6.3.8	Electronic remote drum level monitoring system	6- 52
6.3.9	Turbine supervisory system (TSS)	6- 53
6.3.10	BFP turbine supervisory instruments	6- 55
6.3.11	Plant performance analysis, diagnosis & optimization (PADO) software	6- 55
6.4	Measuring Instruments (Primary & Secondary)	6- 59
6.4.1	Configuration, maintenance, diagnostics & record-keeping facility for electronic transmitters and analysers	6- 59
6.4.2	Specification for electronic transmitters for pressure (DP), flow and level	6- 60
6.4.3	Temperature sensing elements and cold junction compensation boxes	6- 62
6.4.4	Flue gas analyser instruments	6- 66
6.4.5	Vibration monitoring system	6- 69
6.4.6	Specification for flow elements	6- 70
6.4.7	Specification for local gauges & rotameters	6- 72
6.4.8	Specification for process actuated switches	6- 74
6.4.9	Specification for indicator, recorders	6- 76
6.4.10	Electric to pneumatic (E/P) converters	6- 77
6.4.11	Displacer type level transmitters	6- 78
6.4.12	Positive displacement type flow transmitters	6- 78
6.4.13	Impact head or ultra sonic type flow meter	6- 79
6.5	Steam and Water Analysis System (SWAS)	6- 82
6.5.1	SWAS panels	6- 82
6.5.2	Specification of analysers	6- 83
6.5.3	System and type of measurements	6- 90
6.5.4	Alarm contacts	6- 92
6.5.5	General	6- 92
6.6	Unit Control Desk, Unit Control Panels, System Cabinets, Local Panels & Transmitters Enclosures/ Racks	6- 93
6.6.1	General	6- 93
6.6.2	Control desk and panel	6- 94
6.6.3	Cabinets, enclosures and panels	6- 95
6.6.4	Local instrument enclosure and racks	6- 96
6.7	Electric Power Supply	6- 97
6.7.1	General	6- 97
6.7.2	Power supply requirements	6- 97
6.7.3	DC power supply system (24 V)	6- 98
6.7.4	Uninterruptible power supply (UPS) system	6- 99



Clause No.	Description	Page No.
6.7.5	Auxiliary equipments	6- 101
6.7.6	Battery racks	6- 102
6.7.7	Load end power supply distribution	6- 102
6.8	Electric Actuators	6- 103
6.9	Process Connection Piping	6- 106
6.9.1	Impulse piping, tubing, fittings, valves and valve manifolds	6- 106
6.9.2	Sample piping system	6- 107
6.9.3	Air supply piping	6- 107
6.9.4	Installation and routing	6- 108
6.9.5	Piping/ tubing support	6- 109
6.9.6	Shop and site tests	6- 110
6.10	Instrumentation Cables	6- 113
6.10.1	General requirements	6- 113
6.10.2	Instrumentation cable specifications	6- 113
6.10.3	Instrumentation cable interconnection and termination philosophy	6- 117
6.10.4	Internal panels/cabinets/system cabinets wiring	6- 120
6.10.5	Cable installation and routing	6- 120
6.10.6	Cable accessories and fittings	6- 121
6.10.7	Field mounted local junction boxes	6- 121
6.10.8	Conduits	6- 122
6.11	Maintenance and Calibration Equipments	6- 123
6.11.1	Test bench	6- 123
6.11.2	Mechanical items	6- 124
6.11.3	Electrical items	6- 127
6.11.4	Other items - for the laboratory	6- 131
6.12	PLC Based Miscellaneous Control Systems	6- 132
6.12.1	General requirements	6- 132
6.12.2	Programmable logic based control system	6- 132
6.12.3	Input/output modules	6- 135
6.12.4	Printer	6- 137
6.12.5	Data communication system (DCS)	6- 137
6.12.6	System reaction time	6- 138
6.12.7	Operator interface displays/ logs	6- 138
6.12.8	Control & power supply scheme	6- 138
6.12.9	Control cabinets / panels / desks	6- 138
6.12.10	Annunciation system	6- 140
6.12.11	Software documentation and software listings	6- 141
6.13	Type Test Requirements	6- 142
6.13.1	General requirements	6- 142
6.13.2	Special requirement for solid state equipment/ systems	6- 143
6.13.3	Type test requirement for C&I systems	6- 144: 149



Clause No.	Description	Page No.
Section- 7 : Civil Works		
7.1	General	7- 1
7.1.1	Intent of specification	7- 1
	Scope of work	7- 3
	Design basis report (DBR)	7- 5
	Field quality plan (FQP)	7- 6
	Construction safety	7- 6
7.2	Site Grading, Leveling, Roads, Storm Water Drainage and Landscaping	7- 7
7.2.1	Site grading and leveling	7- 7
	Roads	7- 8
	Grading and storm water runoff drainage	7- 10
	Landscaping and ground cover design criteria	7- 12
7.3	Buildings and Structures- Main Plant	7- 13
7.3.1	General	7- 13
	Buildings	7- 13
7.4	Drains and Plumbing	7- 16
7.4.1	General	7- 16
	Major components	7- 16
	Description	7- 16
	Roof drains design criteria	7- 16
	Trenches, floor, equipment and oil drains design criteria	7- 17
	Hot drains design criteria	7- 17
	Plumbing design criteria	7- 17
	Sanitary and plumbing fittings	7- 18
7.5	Civil/ Structural Design Criteria	7- 21
7.5.1	Introduction	7- 21
	Natural phenomena design criteria	7- 21
	Design loads	7- 22
	Special requirements of design to avoid corrosion problems	7- 27
	Basic requirements for all civil works	7- 30
	Earthwork and rockwork	7- 37
	Concrete works	7- 51
	Steel and other metals	7- 84
	Material storage structures	7- 88
	Boiler and ESP support structures	7- 89
	Architecture	7- 91
	Site	7- 103
	Pile foundations	7- 104
7.6	Finishing Schedule	7- 106
7.6.1	General	7- 106
	Interior and exterior finishes	7- 106
Table 1	Interior Finishing Schedule	7- 106
Table 2	Exterior Finishing Schedule	7- 110: 110



Clause No.	Description	Page No.
Section- 8 : Quality Assurance Plan		
8.1	Quality Assurance System	8- 1
8.2	Steam Generator and Auxiliaries	8- 3
8.2.1	Pressure parts	8- 3
	Boiler water circulation pumps	8- 8
	Air preheaters, steam coil air pre-heater and fuel oil heaters	8- 9
	Soot blowers	8- 9
	ID, FD and PA fans	8- 9
	Coal mills, pulverised coal piping and burners	8- 10
	Coal Feeders	8- 10
	Boiler structure, ducts, hoppers, dampers etc.	8- 11
	Electro- static precipitators	8- 12
8.3	Steam Turbine Generator and Auxiliaries	8- 14
8.3.1	Steam turbine	8- 14
	Integral auxiliaries of steam turbine	8- 22
	Steam condenser	8- 25
	Feed water heaters, drain coolers, gland steam condenser and deaerator	8- 26
	Boiler feed pumps	8- 29
	Condensate extraction pumps (CEP)	8- 33
	Condensate polishing unit (CPU)	8- 35
	Condenser on-line tube cleaning system	8- 38
	Debris filter	8- 39
8.4	High Pressure Piping, Valves, Thermal Insulation and Miscellaneous Systems/ Equipment	8- 40
8.4.1	High pressure piping and fittings	8- 40
	Power cycle valves	8- 43
	Metallic expansion bellows	8- 46
	Hangers and supports	8- 46
	Thermal insulation, refractory, lagging and cladding	8- 47
	Low pressure piping, valves and fittings etc.	8- 47
	Equipment cooling water (ECW) system	8- 51
	EOT cranes and hoists	8- 52
	Elevators	8- 54
	Air conditioning system	8- 54
	Ventilation system	8- 59
	Miscellaneous items/ equipments	8- 59
8.5	Field Erection Checks and Tests	8- 61
8.5.1	Hydraulic test of pressure parts	8- 61
	Turbine assembly	8- 61
	Condenser assembly	8- 61
	General	8- 62



Clause No.	Description	Page No.
8.6	Electrical Systems	8- 63
8.6.1	Generator and auxiliaries	8- 64
8.6.2	Generator isolated phase busducts and neutral grounding equipment	8- 78
8.6.3	Power transformers	8- 82
8.6.4	HT busducts	8- 88
8.6.5	Auxiliary service transformers	8- 90
8.6.6	Motors	8- 94
8.6.7	11kV, 3.3kV switchgear	8- 97
8.6.8	415V switchgear and busduct	8- 103
8.6.9	Power and control cables	8- 109
8.6.10	Installation of cables, earthing system and lightning protection system	8- 118
8.6.11	DC storage battery	8- 122
8.6.12	Battery charger	8- 127
8.6.13	Protection and relay panel for generator, generator transformer and UATs	8- 130
8.6.14	Emergency diesel generating set	8- 133
8.6.15	Electro- static precipitator (ESP)	8- 138: 141
Section- 9 : Mandatory Spares		
9.0	General	9- 1
9.1	Steam Generator and Auxiliaries	9- 2
9.1.1	Pressure parts	9- 2
9.1.2	Headers	9- 3
9.1.3	Superheater and reheater attemperation system	9- 3
9.1.4	Steam drum	9- 3
9.1.5	Boiler water circulation pumps	9- 4
9.1.6	Fans	9- 4
9.1.7	Coal pulveriser	9- 8
9.1.8	Feeders	9- 9
9.1.9	Coal burners and coal pipe bends	9- 10
9.1.10	Seal air fan	9- 10
9.1.11	Air preheaters (APH)	9- 10
9.1.12	Fuel oil system	9- 13
9.1.13	HEA ignitors	9- 15
9.1.14	Soot blowers	9- 16
9.1.15	Valve	9- 17
9.1.16	Superheater spray block valve	9- 19
9.1.17	Reheater spray block valve	9- 20
9.1.18	Boiler main steam stop valve	9- 20
9.1.19	Boiler feed check valve	9- 20
9.1.20	Start up vent valves	9- 21
9.1.21	Economiser recirculation valve	9- 21



Clause No.	Description	Page No.
9.1.22	Auxiliary steam pressure reducing and desuperheating (PRDS) system	9- 21
9.1.23	Fuel oil system	9- 22
9.1.24	Variable frequency drive (VFD) system (if applicable)	9- 23
9.1.25	Electrostatic precipitators (ESP)	9- 25
9.2	Steam Turbine and Auxiliaries	9- 28
9.2.1	Steam turbine	9- 28
9.2.2	Emergency stop valves	9- 30
9.2.3	HP control valves	9- 30
9.2.4	IP stop valves	9- 30
9.2.5	IP control valves	9- 30
9.2.6	Drain valves with actuators	9- 31
9.2.7	Gland steam system	9- 31
9.2.8	Turning gear	9- 31
9.2.9	Turbine governing and protection system	9- 31
9.2.10	Turbine lubricating oil system	9- 32
9.2.11	Turbine control fluid system	9- 33
9.2.12	Turbine thrust bearing trip device	9- 33
9.2.13	Automatic turbine testing changeover valve	9- 33
9.2.14	HP bypass system	9- 34
9.2.15	LP bypass system	9- 34
9.2.16	NRVs on CRH line	9- 35
9.2.17	NRVs on extraction lines	9- 35
9.2.18	HP heaters	9- 35
9.2.19	LP heaters	9- 35
9.2.20	Gland steam condenser	9- 36
9.2.21	Drain cooler	9- 36
9.2.22	Deaerator	9- 36
9.2.23	Steam dumping device	9- 36
9.2.24	Condenser	9- 36
9.2.25	Condenser on- line tube cleaning system	9- 37
9.2.26	Boiler feed pumps	9- 37
9.2.27	Lubricating oil system for motor driven BFP	9- 39
9.2.28	Lubricating oil system for turbine driven BFPs	9- 39
9.2.29	Condensate extraction pumps (CEPs)	9- 40
9.2.30	Condensate polishing unit	9- 40
9.2.31	Debris filters	9- 41
9.3	High Pressure Piping, Valves, Thermal Insulation and Miscellaneous Systems/ Equipment	9- 42
9.3.1	Power cycle piping system	9- 42
9.3.2	Thermal insulation, refractory, lagging and cladding	9- 43
9.3.3	Low pressure piping system	9- 43
9.3.4	Equipment cooling water (ECW) system	9- 43



Clause No.	Description	Page No.
9.3.5	HP and LP chemical dosing systems	9- 45
9.3.6	EOT crane	9- 46
9.3.7	Electric hoists	9- 46
9.3.8	Elevators	9- 47
9.3.9	Air conditioning system	9- 51
9.3.10	Ventilation system	9- 53
9.3.11	Miscellaneous valves	9- 55
9.4	Electrical Systems	9- 56
9.4.1	Generator and auxiliaries	9- 56
9.4.2	Generator isolated phase busducts (IPBD) and neutral grounding system	9- 58
9.4.3	Power transformer	9- 58
9.4.4	11kV and 3.3kV segregated phase busducts	9- 60
9.4.5	Auxiliary service transformers	9- 60
9.4.6	Motors	9- 61
9.4.7	11kV and 3.3kV switchgears	9- 62
9.4.8	415V switchgear and non-segregated phase busduct, DC boards	9- 64
9.4.9	Power and control cables	9- 66
9.4.10	Battery	9- 66
9.4.11	Battery chargers	9- 66
9.4.12	Control, metering and protection panels	9- 66
9.4.13	Emergency diesel generating set	9- 68
9.5	Control and Instrumentation System	9- 69
9.5.1	Distributed digital control monitoring & information system (DDCMIS)	9- 69
9.5.2	SG related sub-systems	9- 71
9.5.3	Measuring instruments	9- 75
9.5.4	Power supply system	9- 76
9.5.5	Process connection piping	9- 77
9.5.6	Instrumentation cable, internal wiring and electrical Field	9- 78
9.5.7	Electrical actuators	9- 78
9.5.8	PLC control system	9- 78
9.5.9	Steam and water analysis system (SWAS)	9- 79
9.5.10	Flue gas analyzer system	9- 80: 80
Drawings		
1	Drg. No. CEA- TE- STD- A- 001	Typical Main Plant Layout Plan at 0.0 m.
2	Drg. No. CEA- TE- STD- A- 002	Typical Main Plant Equipment Layout Plan at Different Elevations.
3	Drg. No. CEA- TE- STD- A- 003	Typical Main Plant Cross- Section.



**STANDARD TECHNICAL SPECIFICATION FOR MAIN PLANT PACKAGE
SECTION- 0**

(SITE SPECIFIC INFORMATION)

0.1 PROJECT NAME

Project Title :

Capacity : 2 xMW
(500 MW or above)

Owner :

0.2 LOCATION

The proposed project site is located at The locational details of the proposed project site are as indicated below:

Latitude ⁰'"N
Longitude ⁰'"E
Height above mean sea level m
Siesmic Zone
Distance from town km
Distance from national highway No. km
Distance from state highway No. km
Distance of nearest airport km
Distance of nearest seaport km



0.3 CLIMATOLOGICAL DATA

Highest monthly mean of daily maximum temperature (°C)
Lowest monthly mean of daily maximum temperature (°C)
Highest monthly mean of daily minimum temperature (°C)
Lowest monthly mean of daily minimum temperature (°C)
Annual mean of daily maximum temperature (°C)
Annual mean of daily minimum temperature (°C)
Extreme highest temperature (°C)
Extreme lowest temperature (°C)
Relative Humidity: Maximum %
Minimum %
Average annual rainfall cm
Heaviest rainfall in 24 hours so far cm
Number of rainy days in a year
Highest monthly mean of wind speed km/h
Lowest monthly mean of wind speed km/h
Maximum wind speed km/h

Seasons	Dry bulb temperature (°C)	Wet bulb temperature (°C)
Summer
Monsoon
Winter

Design ambient temperature (unless specified otherwise)	50°C
---	------



0.4 FUEL

0.4.1 Source of Fuel

Coal to be used for the power station shall be sourced from coal mines. The coal shall be transported to the project site by Indian Railways/ MGR system (as applicable for the project). Proximity of Railway line to site from Railway Station is about km. The railway link shall also be used for transportation of heavy equipment to site during construction phase and to bring main and support fuel to the power plant during operation of plant.

0.4.2 Coal and Ash Analysis

Proximate and ultimate analysis of coal (on as received basis)

Sl. No.	Particulars	Units	Performance coal	Worst coal
A.	Proximate analysis			
1.	Moisture	%		
2.	Ash	%		
3.	Fixed carbon	%		
4.	Volatile matter	%		
	Total	%	100	100
B.	Gross calorific value	kcal/kg		
C.	Grindability index	HGI		
D.	Ultimate analysis			
1.	Carbon	%		
2.	Hydrogen	%		
3.	Sulphur	%		
4.	Nitrogen	%		
5.	Oxygen (by difference)	%		
6.	Moisture	%		
7.	Ash	%		
	Total	%	100	100



Ash analysis

Characteristics	Range/ value
SiO ₂	%
Al ₂ O ₃	%
Fe ₂ O ₃	%
TiO ₂	%
CaO	%
MgO	%
Chloride as Cl	%
Sulphate as SO ₄	%
Alkalies as NaOH	mg/kg
Chromium as Cr	mg/kg
Mercury as Hg	mg/kg
Lead as Pb	mg/kg
Cadmium as Cd	mg/kg
Nickel as Ni	mg/kg
Zink as Zn	mg/kg
Copper as Cu	mg/kg

0.4.3 Secondary liquid fuels

Heavy fuel oil (HFO/HPS/LSHS as applicable) shall be used for start-up, coal flame stabilization and low load operation of the steam generators. Light diesel oil (LDO) shall be used for cold start up of the steam generators.



0.5 WATER SYSTEM

[Source (sea or river etc.) and quality of cooling water (sea water or clarified water etc.) for condenser and other heat exchangers and type of cooling system (once through or closed cycle) to be described herein]

Chemical analysis of raw water/ sea water applicable for this project to be indicated as below:

S. No.	Constituents	Concentration
i)	Calcium hardness, mg/l as CaCO ₃	
ii)	Magnesium hardness, mg/l as CaCO ₃	
iii)	Sodium, mg/l	
iv)	Potassium, mg/l	
v)	Total cations, meq/l	
vi)	P-Alkalinity, mg/l as CaCO ₃	
vii)	M-Alkalinity, mg/l as CaCO ₃	
viii)	Chloride, mg/l	
ix)	Sulphate, mg/l	
x)	Nitrate, mg/l	
xi)	Total Anions, mg/l	
xii)	Dissolved silica, mg/l as SiO ₂	

0.6 DEMINERALISED WATER FOR POWER CYCLE MAKE UP

The quality parameters of demineralised water to be used for make up to the condenser hotwell and make up to the closed cycle equipment cooling water (ECW) system shall be as below:

- pH : 6.8 – 7.2
- Silica, ppm as SiO₂ : ≤ 0.01
- Conductivity, micro mho/cm : ≤ 0.1



STANDARD TECHNICAL SPECIFICATION FOR MAIN PLANT PACKAGE

SECTION- 1

(GENERAL)

1.1 INTENT OF SPECIFICATION

This specification is intended to cover the design, engineering, manufacture, inspection and testing at manufacturer's works, supply, packing and delivery at project site, unloading, storage and in plant transportation at site, erection, supervision, pre-commissioning, testing, successful commissioning, performance testing and handing over of main plant package for sub-critical thermal power project having two (2) units of 500 MW (or above) consisting of steam generator, steam turbine– generator, electrical system, and C&I system along with all associated auxiliaries and accessories and associated civil works as specified herein.

1.1.1 Scope of the proposal shall cover following activities and services in respect of all the equipment and works specified in various sections of this specification:

- i) Basic Engineering of all equipment and equipment systems;
- ii) Detailed design of all the equipment and equipment system(s) including civil works;
- iii) Providing engineering drawings, data, instruction manuals, as built drawings and other information for purchaser's review, approval and records;
- iv) Compliance with statutory requirements and obtaining clearances from statutory authorities, wherever required;
- v) Complete manufacturing including shop testing;
- vi) Packing and transportation from the manufacturer's works to the site including customs clearance, port charges, if any;
- vii) Receipt, movement to proper storage, storage, preservation and conservation of equipment at the site, movement from storage area to interim/ final foundation location;
- viii) Fabrication, pre-assembly, if any, erection, testing, pre-commissioning and commissioning and putting into satisfactory operation all the equipment including successful completion of initial operation;



- ix) Performance guarantee/acceptance tests after successful completion of initial operation;
- x) Guaranteeing equipment performance for a period of 12 months from the date of commercial operation;
- xi) Supply of mandatory spares as per specified list and recommended spares for three years of normal operation on FOR site basis;
- xii) Supply of any other equipment including special tools and tackles, commissioning spares and services required for satisfactory completion of the project and operation and maintenance of the same;
- xiii) Training of purchaser's personnel nominated by the purchaser during erection, testing and commissioning, and for operation and maintenance;
- xiv) Reconciliation with customs authorities, in case of imported equipments;
- xv) Satisfactory conclusion of the contract;
- xvi) All items and equipment though not specifically mentioned in the specification, but needed to complete the system to meet the intent of the specification shall be deemed to be included in the scope of the bidder.

It is not the intent to completely specify all details of design and construction, but only to lay down broad sizing and quality criteria for the major equipment and systems and it is expected that the equipments shall conform in all respects to high standards of engineering, design and workmanship and shall be capable of performing in continuous commercial operation up to the contractor's guarantee in a specified manner acceptable to the purchaser.



1.2 SCOPE OF SUPPLY

The scope of supply and services covered under this specification shall broadly consist of the following:

1.2.1 Steam Generator and Auxiliaries

The scope shall include all equipment and materials required for steam generators and their auxiliaries, power cycle piping, auxiliary piping and electrostatic precipitators etc. for two (2) units of 500MW (or above) as detailed hereunder. The scope for each steam generator shall include but not limited as hereunder:

- 1.2.1.1 Water cooled furnace complete with furnace bottom hoppers, drains etc.
- 1.2.1.2 Boiler water circulation pumps complete with drive motors, discharge isolating valves complete with their cooling and lubricating system.
- 1.2.1.3 Steam generator drum with internals, mounting and fittings.
- 1.2.1.4 Steam generator integral piping, valves and associated fittings.
- 1.2.1.5 Superheaters including safety valves, drains, start up vents, air release valves, nitrogen connections, sampling connections etc.
- 1.2.1.6 Reheaters including safety valves, drains, start up vents, air release valves, sampling connection with reheater isolating device etc.
- 1.2.1.7 Superheater and reheater desuperheating spray systems complete in all respects and conforming to ASME standard No. TWDPS, Part-I.

Each desuperheating spray system shall essentially consist of the following:

- i) Two (2) numbers of pneumatically actuated spray control valves each rated for the full duty.
- ii) One (1) number motor/ pneumatic operated isolating valve upstream of each spray control valve.
- iii) One (1) number manual isolating valve downstream of each spray control valve.
- iv) Drain lines with individual isolating valves.
- v) Fast acting pneumatically operated block valve (with DC solenoid) at upstream of the spray control station in the common attemperation line.
- vi) Non-return valve in the common attemperation line near water spray injection point.



vii) Welded type attenuation water flow nozzle alongwith all accessories for flow measurements/controls.

1.2.1.8 Main steam stop valves including integral bypass valves on each main steam line at boiler outlet complete with their motor drives and control equipment.

1.2.1.9 Economizer with recirculation piping (as required), vents, drains and sampling connections etc.

1.2.1.10 Two (2) regenerative tri-sector air pre-heaters (APHs) for primary and secondary air system or two (2) regenerative bi-sector APHs each for primary air and secondary air systems. Each APH shall be complete with:

i) One (1) peripheral AC drive connected to drive Airheater along with automatic clutching/declutching arrangement.

ii) One (1) independent air motor drive along with automatic clutching/ declutching arrangement.

iii) Air receiver of storage capacity not less than 10 minute operation requirement of air motors (compressed air for driving air motor shall be drawn from service air system from common terminal point in boiler area).

iv) Piping and fittings, air filters, regulators including suitable solenoid valves for automatically admitting air for starting air motors in case of power failure, pressure switches on air line to air motor(s) etc.

v) Air heater standstill sensing device with necessary logic components, accessories and indicating lights, housed in the enclosure. The motion to be precluded up at appropriate location of the rotor shaft.

vi) Permanent fire fighting equipment on both gas as well as air sides and also on both cold as well as hot end sides including, spray nozzles, valves and pipe work connected to fire water system (water to be tapped from common terminal point in boiler area).

vii) Thermocouple type fire sensing device complete with accessories.

viii) Dust hoppers with bracing, stiffeners, supporting structure, baffles, access door, mating flanges, expansion joints, RF type ash level indicators etc., and suitable approach platform for each hopper.

ix) Off load water washing facility alongwith water supply pipework (water to be tapped from service water system) and drainage piping.

x) Adequate number of thermocouples or platinum resistance temperature detectors (RTD) for measuring cold and hot end bearing metal temperature.

xi) Temperature switches on the bearings for interlock purpose.



- xii) Forced lubrication system shall be provided for bearings and shall include 2x100% capacity oil pumps with motor, 2x100% oil coolers, 2x100% oil filters, one (1) oil tank etc. as applicable.
 - xiii) Any other equipment/accessories /instrument etc., to make the system complete for reliable and safe operation.
- 1.2.1.11 Two (2) steam coil air pre-heaters (SCAPH) for secondary air at FD fan outlets bypass ducts with necessary dampers, drain pipe to IBD tank and necessary piping, valves and fittings for steam services. In case of bi-sector type air pre-heaters, two (2) nos. SCAPHs shall be provided for PA system also.
- 1.2.1.12 Coal preparation and firing system for direct firing complete with gravimetric raw coal feeders, chutes, coal pulverisers, primary air fans, seal air fans, pulverised fuel (PF) pipes, PF burners and burner wind box, coal burners tilt drives (if applicable) with linkages and complete actuator assemblies, air registers, igniters, scanners, scanner fans etc. as required.
- A) Raw Coal Chutes and Bunker Shut Off Valves
- i) Motor operated (sliding gate type) raw coal bunker shut off gate at the bunker mouth and manually operated gate at RC feeder inlet (both shall be for each coal feeder).
 - ii) Chain wheel and chain for manual operation of bunker shut off gate and RC feeder inlet valve from the feeder floor.
 - iii) Coal chute between bunker shutoff gate and RC feeder inlet.
 - iv) Coal chute between outlet of feeder and inlet of mill alongwith motor/pneumatic operated shut off gate at RC feeder outlet.
 - v) Permanent facility of bunker emptying chute to enable unloading of bunkers on trucks at ground level.
 - vi) Suitable couplings (Dresser or equivalent) with 410 stainless steel liner ring one on each chute between RC feeder and mill and one on each chute between coal bunker and RC feeder.
 - vii) Devices to detect choking/flow/no flow of coal in the coal chute between coal bunker and RC feeder.
 - viii) Remote (UCB) pneumatic/ motor operated shut off gate between RC feeder and coal mill.
 - ix) A local access platform for maintenance/operation of bunker shut-off valves.



B) Raw Coal Feeders

Gravimetric type raw coal feeders with microprocessor based precision weighing and calibration devices, one for each mill. The feeders shall be complete with motor, coupling, coupling guards, base plate, foundation bolts, sliding joints, paddle type switches to detect presence or absence of coal on feeder or choking of feeder, speed variator, speed sensors, coal motion monitors, and strain gauge type weight measuring system with all instrumentation.

C) Coal Pulverisers

- i) The coal pulverisers shall be vertical spindle type medium speed mills (like pressurized type bowl mills, ball and race mills such as MBF/MPS/MRS mills etc. or the approved equivalent). The coal pulverisers shall conform to sizing/ standby requirements stipulated elsewhere in the specification.
- ii) The coal pulverisers shall be installed on rigid RCC foundations.
- iii) Each pulveriser shall be complete with all wear parts, grinding elements, classifier and shall be provided with platforms around the pulveriser, lubrication systems (comprised of 2x100% pumps, 2x100% cooler and 2x100% filters for each pulveriser), drive motors, auxiliary gear, instrument tapping points and any other equipment necessary for safe and efficient operation of pulveriser. Adequate number of temperature sensors, local indicators and signaling contacts for bearings and lube oil systems shall be provided. Independent purge meters, air filter cum regulator sets, and required local gauges and switches for milling system shall be provided at air inlet of each coal pulveriser. Adequate number of thermocouple type detection system as a composite and complete unit with all required accessories with adequate redundancy shall be provided.
- iv) Proven fire detection and fire extinguishing systems in line with the standard practice of the manufacturer shall be provided. In case of CO₂/N₂ based system, the scope of supply shall also include the required cylinder/piping and valves network etc. In case, the proposed type of mill requires inerting during start-up / shut-down of the mill to ensure safety of operation, suitable system alongwith all piping valves instrumentation, interlock system etc. shall also be provided.
- v) Portable lubricating oil purification plant for pulverisers complete with tank, pumps, purifiers, piping, valves fittings and local instruments and control panels.

D) Primary Air Fans

- i) Two (2) numbers of two stage axial PA fans for each steam generator, with hydraulic blade pitch control system each with motor, base plates, foundation bolts, inlet box, inlet bird and trash screen, inlet rain water canopy, inlet cone, diffuser, coupling, coupling guard and silencer. Each

PA fan shall be provided bearing lubrication and hydraulic blade pitch control unit consisting of :

- a) 2x100% oil pumps, each with motor, coupling and coupling guard.
 - b) 2x100% oil coolers.
 - c) 2x100% oil filters.
 - d) One (1) oil tank.
 - e) Instrumentation, connected piping, valves and fittings.
 - f) Electrical/ pneumatic actuators with all accessories.
- ii) PA fans shall be installed on rigid RCC foundations.
- E) Seal Air Fans
- 2x100% seal air fans common for all the pulverisers of one steam generating unit shall be provided. The fans shall be complete with motors, base plate, foundation bolts, coupling and coupling guard, seal air piping, dampers, supports etc. 1x100% self cleaning filter (Dynavane or eqvt.) on common line to fans shall be provided alongwith necessary manual isolation dampers at suction and discharge for maintenance. The seal air fans shall take suction from cold primary air header. Alternatively suction may be taken from atmosphere also.
- F) Pulverised Coal (PC) Piping
- i) Pulverised coal piping from mills to burners including ceramic lined pipe and bends as per the specifications.
 - ii) Power operated shut off gate before each coal burner and a power operated flap type mill discharge valve at each classifier outlet on each pulverized fuel pipe.
- G) Coal sampling system for obtaining samples from the mill outlet. The minimum number of coal sampling systems to be provided for each steam generator shall be equal to atleast the number of PF pipe outlets from one coal pulveriser.
- H) Dirty pitot tubes per steam generator for checking on line pulverized coal/primary air flow balance between the PF pipes from a mill. The no. of dirty pitot tubes provided for each steam generator shall be equal to the no. of pulverized coal pipes from a coal pulveriser.

1.2.1.13 Fuel oil pumping and steam heating units complete with inter-connecting piping for supply and return oil mains, and valves inclusive of all control valves such as pressure control, temperature control, flow control, self actuated valves, instruments, sensing devices, trip valves, strainers, pressure switches, differential pressure switches,



temperature switches and all other accessories to make the system complete. The oil flow measurement device for the measurement of fuel oil consumption rate shall be included in the bidder's scope.

Fuel oil system shall cater to heavy fuel oils (HFO/LSHS/HPS)¹ and light diesel oil firing requirements of two (2) Steam Generators.

A) Heavy Fuel Oil System

The scope of above shall include but will not be limited to following:

- i) Three (2 working+1 standby) steam jacketed/ electrically traced rotary positive displacement type heavy fuel oil pumps with motor, coupling, coupling guards etc.
- ii) Three (2 working+1 standby) steam oil heaters, each heater with oil temperature control valve, bypass control valve, isolating valves and relief valves to relieve excess oil pressure.
- iii) Three (2 working+1 standby) steam jacketed/electrically traced manually operated duplex coarse filters at heavy fuel oil pumps suction.
- iv) Base plates, foundation bolts, nuts and bolts.
- v) Fuel oil burners complete with diffusers, tips extension pipes, atomizers, burner shut of valves, flexible hoses and all other ancillaries.
- vi) Oil connections to each burner from ring main. Also a common fine filter and common flow meter shall be provided in HFO system.
- vii) HEA/light oil igniters for each burner.
- viii) Complete piping alongwith suitable hangers, supports, pipe trestles etc. including following:
 - a) Fuel oil piping with in the terminal point indicated.
 - b) Interconnecting fuel oil piping integral to the system to make it complete.
 - c) Auxiliary steam piping.
 - d) All drain oil piping from drain point to drain oil tanks and from drain oil tank to fuel oil storage tanks.

¹ The type of heavy fuel oils as applicable for specific project to be mentioned by purchaser.



- e) Vent piping along with local collection bucket for collecting of leak off oil from vents/relief valves.
- f) Steam/electrical tracing for heavy fuel oil piping complete with all accessories. In case of steam tracing, steam traps shall be provided at every 40 mtrs.
- g) Blow off piping.
- h) Recirculation piping around firing aisle.
- i) All condensate piping up to the flash tank and from flash tank to the drain pit including all valves and fittings.
- ix) One (1) drain oil tank of 6m³ capacity with steam coil heaters and with one oil transfer pump with motor, duplex filter at suction and other accessories for each steam generator to transfer drain oil from boiler area to HFO storage tank(s).
- x) One (1) drain oil tank common for two (2) steam generator in pressurizing pump house area having 10m³ capacity with steam coil heater and one oil transfer pump with motor, duplex filter at suction and other accessories to transfer drain oil from pump house to HFO storage tanks.
- xi) One condensate flash tank of 6m³ capacity complete with all accessories.
- xii) One (1) no. HFO cooler common for each steam generator with necessary automatic oil temperature control system to cool the return oil from the steam generators to the temperature of HFO in the storage tank with necessary cooling water piping and provide all necessary valves, control valves and fittings, etc.
- xiii) Adequate local and equipment mounted instrument and devices with adequate signaling and connects/connections required for pressure, temperature and other controls for supervision and interlocking with all associated auxiliary during purging, shut down and of sensing device to remain unaffected by oil fill dirt or by ambient conditions where it will be installed.
- xiv) Trip valves on common fuel oil line to each boiler and nozzle valves for each individual burner alongwith all accessories such air filter, regulators, limit switches, control valves, and connecting fittings to make the system complete.
- xv) Recirculation valve of heavy duty type to work with the furnace safeguard and supervisory system (FSSS).
- xvi) All other piping valves and accessories as necessary.



- xvii) Facilities shall be provided for flushing of complete heavy fuel oil cleaning, transportation, recirculation and firing system (piping, pumps, heaters, filter, valves, etc.) using light diesel oil during long shut down of unit(s). Contractor's scope shall include all piping, valves, fittings, pumps hoses etc. needed for this purpose. The facility shall cover flushing of heavy fuel oil system of each unit independently, as well as flushing of common systems.
- xviii) Complete insulation and cladding of heavy fuel oil piping drain/flash tanks, steam and condensate piping and accessories with outer finish.
- xix) Supply of one (1) no. flow meter of oval wheel type including all its accessories.
- xx) Two (2) nos. sump pumps with motors alongwith steam jacketing/ electrically traces.
- xxi) All local instrumentation (gauges, switches, transmitters etc.) and associated control devices for HFO system.
- xxii) Control system

B) Light Diesel Oil (LDO) System

A LDO preparation and firing system shall be provided having a firing capacity equivalent to 7.5% BMCR heat input requirements of two (2) steam generators. The LDO burners (preferably same burners as for HFO firing) of required capacity shall be installed at the lowest oil elevation.

The system shall include three nos. (2W+1S) of pressurizing pumps, piping, valves including control valves, strainers, burners, flow meter with control and instrumentation etc., with equipment redundancy and flexibility of operation similar to those for HFO firing system. Control for LDO pressurizing system (including controls for purchaser's unloading and storage system) shall be from the PLC/ DDCMIS based control system for HFO.

Approval is required from statutory authorities for the entire fuel oil pumping installation. Contractor shall prepare all necessary drawings, data and documents as per the requirements of the statutory authority and obtain the necessary approval from the authorities.

1.2.1.14 Balanced draft system including forced draft fans and induced draft fans complete with their lubrication system.

A) Forced Draft Fans

- i) Two (2) nos. of axial type, constant speed, variable pitch controller FD fans each with drive motor, base plates, foundation bolts and nuts, inlet bird and trash screen, suitable arrangement to prevent rain water entry to



fan motor, coupling and coupling guard and acoustic silencer. Each fan shall be provided with bearing lubrication and hydraulic blade pitch control unit consisting of:

- a) 2x100 % oil pumps, each with motor drive, coupling and coupling guard.
- b) 2x100% oil coolers.
- c) 2x100% filters, differential pressure switches.
- d) One (1) oil storage tank.
- e) Instrumentation, interconnecting piping, valves and fittings including pressure relief valves and non return valves (NRVs) etc.
- f) Electrical/ pneumatic actuators with all accessories.

Silencers shall be provided at the suction of the fans to limit the noise levels to specified values.

- ii) FD fans shall be installed on rigid RCC foundations.
- iii) Adequate nos. of duplex platinum RTD's (100 ohms at 0⁰C) and temperature indicators shall be provided for bearing metal temperature control and monitoring.

B) Induced Draft Fans

- i) Two (2) nos. ID fans, radial type with variable speed, variable frequency/hydraulic coupling or axial type with constant speed, variable pitch controller, each with drive motor, base plate, foundation bolts and nuts, inlet box, discharge case, coupling and coupling guard. Each ID fan shall be provided with bearing lubrication unit consisting of:
 - a) 2x100% oil pumps each with motor, coupling and coupling guard.
 - b) 2x100% oil coolers.
 - c) 2x100% filters, differential pressure switches, etc.
 - d) One (1) oil storage tank.
 - e) Instrumentation, connected piping, valves and fittings including pressure relief valves and NRVs etc.
- ii) ID fans shall be installed on rigid RCC foundations. The fan shall be supplied with base plates, foundation bolts, suitable arrangements to prevent rain water entry to fan motor etc.



- iii) Adequate number of duplex platinum RTDs (100 ohm at 0°C) and temperature indicators shall be provided for bearing metal temperature control and monitoring.
- iv) The design and supply of transition duct at chimney entrance shall be in the scope of contractor. Contractor to submit detailed arrangement drawing for the transition duct alongwith all required expansion joints, guide vanes etc. which will be connected to vertical and circular chimney flues.

C) Penthouse Ventilation/ Cooling Fans

2x100% capacity fans complete with remote start/ stop facility.

- 1.2.1.15 Air and gas duct work with expansion joints, including isolating, regulating and hand-operated dampers, and spindles with levers, operating gears, linkages and actuator assemblies together with all accessories.

The scope of ducting shall include but not limited to the following:

- i) Cold air inlet duct to FD fan suction, from FD fan discharge to APH bypass ducting for locating SCAPH down stream of FD fan.
- ii) Cold air inlet duct to PA fan suction, from PA fan discharge to APH.
- iii) Cold air duct from each PA fan discharge to coal mills.
- iv) Hot air duct from each APH to burner wind box and to coal mills.
- v) Flue gas duct from economizer outlet to APHs inlet ducts and from APHs outlet to ESP inlets. Economizer dust hoppers, (if applicable) shall be provided with RF type ash level indicators.
- vi) Flue gas ducts from electro-static precipitators (ESP) outlets to ID fans inlets and ID fans outlets to chimney flue inlet including chimney inlet transition piece/ducting. The transition piece/ducting shall connect flue gas duct to vertical chimney flues liners. All connections, expansion joints (just outside the chimney), supporting structures for transition piece/ ducting, matching flanges with adequate stiffening at the terminal point, to connect with the chimney flue liners (of purchaser) shall be included in contractor's scope.
- vii) Adequately sized flow splitters, plates/duct stiffening devices, bracing, side plates, expansion joints, matching flanges, access doors and brackets, support structure and hangers, sampling points, ash hoppers, etc.
- viii) Expansion joints wherever necessary shall be installed.
- ix) Economiser bypass ducting with diverter damper and ash collection hopper, if required, alongwith RF type ash level indicators.



- x) Common air ducting at FD fan, PA fan, APH outlets and common flue gas ducts at ESP inlet and outlet.
- xi) Any other ducting required for the completeness of the system including interconnecting ducting and economizer bypass, as applicable and indicated in various locations in the scheme of coal, air and gas flow diagram.
- xii) Matching flanges on the flue gas duct after ID fan discharge and before chimney to be connected with flue gas desulphurisation system ducts to be installed in future by purchaser.
- xiii) Pipe reducers/expanders, matching flanges in flue gas and air ducts for thermocouples and thermometers etc. T-connections along with root valves in impulse pipes from where tapings are required to be taken for remote measurements in case provision does not exist for separate tapping points with root valves from the equipments for remote measurements and controls.

1.2.1.16 Each unit shall be provided with high capacity and low capacity auxiliary steam pressure reducing and desuperheating station (PRDS) alongwith high temperature and low temperature auxiliary steam headers.

A) High Capacity PRDS

- i) One number angular type electro-hydraulically/ electro-pneumatically operated combined pressure reducing cum de-superheating valve rated for full duty. Separate pressure reducing and desuperheating valves shall also be acceptable.
- ii) One number manual isolating valve at the downstream of the combined pressure reducing cum de-superheating valve.
- iii) One number motorised isolation valve with integral bypass at the upstream of the pressure reducing cum de-superheating valve.
- iv) One number non-return valve downstream of PRDS..
- v) One number of pressure and temperature control valve, electro-hydraulically/electro-pneumatically operated on the de-superheating spray water line and one number of pressure and temperature motorised control valve on the bypass line to the electro-hydraulically electro pneumatically operated control valve for similar duty.
- vi) One number motorised isolation valve at the inlet of each of electro-pneumatic as well as motorised control valve on the de-superheating spray water line.



- vii) One number manual isolating valve at the down stream, each of electro-hydraulic/ electro-pneumatic as well as motorised control valves on the desuperheating spray water line.
 - viii) One number of non-return valve on the common spray water line.
- B) Low Capacity PRDS
- i) One number electro-hydraulically/electro-pneumatically operated pressure reducing valve rated for full duty.
 - ii) One number motor operated pressure reducing valve rated for full duty on the bypass line to the main pressure reducing valve.
 - iii) One number motorised isolation valve at the inlet of main pressure reducing valve and one number manual isolation valve on the outlet of the main pressure control valve.
 - iv) One number motorised isolation valve at the inlet of the motor operated pressure reducing valve on the bypass line and one number manual isolation valve on the outlet of pressure control valve on the bypass line.
 - v) A non-return valve on downstream side of low capacity PRDS.
 - vi) One number desuperheater in between the interconnection of high and low temperature unit headers.
 - vii) One number each of pressure and temperature control valve, electro-hydraulically/electro-pneumatically operated on the desuperheating spray water line alongwith one number each of motorised pressure and temperature control valve on the bypass line for the similar duty.
 - viii) One number motorised isolation valve at the upstream of the pressure and temperature control valve on the main desuperheating spray water line.
 - ix) One number motorised isolation valve on the upstream of motorised control valves on the bypass line of desuperheating spray water line.
 - x) One number manual isolation valve downstream of steam pressure reducing valve on each of the main and bypass line alongwith the downstream non return valve on the common header.
 - xi) One no. pneumatically operated quick acting block valve (with solenoids) upstream of the desuperheating spray water control station in the common line feeding to the high capacity and low capacity desuperheating spray water control stations.

As per manufacturer's standard and proven practice, each unit may be provided with only high temperature auxiliary steam header and auxiliary steam requirement at lower parameters met with PRDS for individual application.



- 1.2.1.17 Continuous and intermittent blow-down vessels and the related piping and level control valves, safety valves, vents, drains, instruments etc.
- 1.2.1.18 Soot blowers and soot blowing system including control panels and motor control centers (MCCs) and automatic steam pressure controlled systems together with all actuators and accessories and necessary/ local/ panel mounted instruments with signaling contacts, including flow switches.
- i) Soot blowers and soot blowing system complete with short retractable rotary wall blowers for the furnace, long fully retractable rotary blowers for superheater, reheater and economizer, sweep action blowers for regenerative air preheater, motor drive for each blower with coupling and coupling guards, base plate frame and holding bolts, speed reducers, cam, chain drives and other ancillaries, emergency hand cranks, flanges, gaskets, seals and bearings for all soot blowers and supporting structures.
 - ii) Soot blower piping including supply piping to all soot blowers through pressure reducing station, drain piping, vent piping, relief valves and escape piping with silencer, support and hangers etc. Complete soot blower piping shall have warm up and automatic self draining features to preclude water being blown on to the heat absorption surfaces. The location of steam service shall be decided by the contractor to meet his requirements.
 - iii) Valves for soot blower operation shall include pneumatically operated pressure reducing control valve, (0-100% capacity) for all types of blowers, with one standby 0-100% capacity motorized/pneumatic operated valve suitable for inching service alongwith position feedback, drain valves, isolating valves with motor drives up stream of each of pressure control valves, all other valves and steam supply lines as required for soot-blower operation, coupling, air purge, vent and relief valves etc. Soot blowers at each elevation shall be connected with the steam line in such a way that the draining of the lines are suitably effected.
- 1.2.1.19 System for Furnace Safeguard and Supervision including burner management, mill automation and secondary air control system complete with all equipments, panels, cubicles, ignitor cabinet, test cabinet, special plug-in cables etc. impulse piping and all other accessories as a complete unit, suitable for the type of fuel specified.
- 1.2.1.20 Electrostatic Precipitator complete with rectifier transformers, hoppers and their heaters, all necessary control and auxiliary panels, switchgears, fittings, rapping mechanisms system with drives and all cables and cabling grounding terminals, thermal insulation and all necessary structural steel works with foundation bolts, nuts, anchoring material etc.
- 1.2.1.21 Two (2) nos. hydraulic test pumps alongwith all connections, fittings etc. (for hydraulic test of boiler pressure parts and pipelines). The pumps shall be of positive displacement type and adequate capacity to develop pressure for testing of pressure parts upto 150% of the design pressure.
-



1.2.1.22 All supporting steel work for the steam generator and its accessories and auxiliaries including the necessary structural steel for all weather canopies at burner and drum level and roofing for all weather canopies and the covering at sides of the steam generator at operating levels with suitable louvers meeting the purchaser's approval.

1.2.1.23 Galleries, walkways, platforms, hand rails, ladders etc.:

- i) Galleries, walkways, platforms, hand rails, ladders and gratings including the interconnecting platforms coming from main building and mill bunker bay to the steam generator as well as the interconnecting platforms coming from mill bunker bay and steam generator platforms to the elevator.
- ii) Necessary access platforms, walkways, handrails, ladders and gratings for proper approach during maintenance shall be provided for all equipments and accessories in the scope of this package. The above provision shall also include the following locations as a minimum.
 - a) Bunker outlet gate
 - b) Mill discharge valve
 - c) All dampers and their drives
 - d) Furnace seal trough level
 - e) All fans and associated motors (continuous platforms shall be provided around the fans and their corresponding motors)
 - f) Air preheaters
 - g) All valves
 - h) All field control and instrumentation equipments.
- iii) All fixtures, embedded parts, steel embedments including fixing lugs and welding between them, foundation plates, nuts, bolts etc. for fixing all the equipments, piping on civil works shall be included in scope work of this package.
- iv) All structures which would be required by the bidder for supporting the piping shall be included in scope of work of this package.
- v) The exact requirements of the access platforms and maintenance platforms etc. depending upon the layout and location shall be as per the best engineering practice and manufacturer's design requirement and shall be subject to purchaser's approval during detailed engineering.



1.2.2 Steam Turbine and Auxiliaries

The scope shall include all equipment and material required for 2x (500 MW or above) capacity steam turbines and its auxiliaries. The scope for each steam turbine set shall include but not limited to the following:

1.2.2.1 Steam turbine

- i) The steam turbine shall be of tandem compound construction, condensing type with six (6) or seven (7) steam extractions at optimum points for regenerative feed heating. HP turbine shall be of double casing design. The HP, IP and LP casings shall be independent of each other **OR** combined HP-IP and separate LP casing(s). LP turbine may consist of two separate turbines. HP inner cylinder, IP cylinder and LP cylinder(s) shall be horizontally split.
- ii) Steam turbine shall be complete with casings, rotors, bearings, temperature detectors, couplings, steam gland seal, rotor turning gear preferably hydraulic type and having local/remote operation facility, hand barring gear, emergency stop and control valves and reheat stop and control valves with their servomotors, removable type steam strainers for start up and normal operation upstream of emergency stop and reheat stop valves, crossover/ cross around piping and electric motors for all its integral subsystems. Steam strainers integral with main steam emergency stop and reheat stop valves are also acceptable.
- iii) Hydraulic/pneumatic power operated quick closing non-return valves (QCNRV) and ordinary non-return valves for each extraction (except for the heater in condenser neck) including steam lines to BFP turbine drives, and for each cold reheat line one hydraulic/ pneumatic power operated QCNRV shall be provided. The type of actuation i.e., hydraulic/ pneumatic shall be as per the standard proven practice of the Manufacturer.
- iv) Steam turbine shall be installed on rigid RCC foundation or on spring supported RCC foundation as per standard proven practice of the manufacturer.

1.2.2.2 Steam turbine integral auxiliary systems

- i) Turbine gland sealing steam system with gland steam condenser, gland steam exhausters, all associated motors, associated piping, valves and fittings, strainers/ filters, specialties, hangers and supports, necessary insulation and complete with instrumentation and control hardware including electro hydraulic/electro pneumatic controller, actuator, electro hydraulic /electro pneumatic converter etc. as to make the system complete in all respects.
- ii) Lubricating oil system (common for turbine generator set) complete with oil tanks, oil purifying system, oil pumps and jacking oil pumps with drive motors, oil coolers, strainers, vapour extractors with drive motors, all interconnecting piping, valves and fittings, hangers and supports, necessary instrumentation and control hardware to make the system complete in all respects.



- iii) Centralised oil storage and purification system (common for all the units) including clean oil tank, dirty oil tank, transfer pumps, purifying unit with interconnecting piping, necessary instrumentation and control hardware to make the system complete in all respects.
- iv) Steam turbine control fluid and its purification system along with its conditioning system complete with control fluid tank, control fluid pumps with drive motors, strainers, accumulator, control fluid coolers, waste fluid tank, purification equipment including fluid circulation pumps with drive motors, associated piping, valves, fittings and specialties, hangers and supports, instrumentation and control hardware to make the system complete in all respects.
- v) Steam turbine governing and protection system complete with electro hydraulic governor with mechanical hydraulic back up or electro hydraulic system with 100% hot back-up, electro hydraulic converter, hydraulic converter, tracking devices, hydraulic speed governor, electrical speed sensors, speed/load adjusting gear, unloading gear (if applicable), vacuum breaker, motor drives, remote trip solenoids, over speed, low condenser vacuum, low lube oil pressure, high axial shift and other trip/protection devices, electrical components associated with electro hydraulic system, test devices and test panel inserts/testing facility etc.
- vi) Steam turbine exhaust hood spray cooling system complete with spray arrangements, associated piping, instrumentation and control devices, valves and fittings, motor/solenoid operated valves and specialties, hangers, supports etc.
- vii) Warming, drain and vent system for steam turbine, associated piping and equipment complete with flash tanks, associated spray system, piping, valves and fittings, valve motor drives, specialties, hangers, supports, insulation, instrumentation and control etc. Drains from main steam, cold reheat and hot reheat lines etc. shall also be connected to these flash tanks.
- viii) Turbine preservation system consisting of adequate numbers of air driers including fans, motors, filters, heater drying wheel, connecting piping, valves, fittings etc. for preservation against corrosion of turbine during idle periods.
- ix) TG integral piping

The scope of work for TG integral piping covered under this specification shall include but not be limited to the following systems:

- a) Lube oil system
- b) Control fluid system
- c) Turbine gland steam sealing system
- d) Exhaust hood spray system
- e) Seal oil system



- f) Stator water cooling system
- g) Hydrogen, carbon dioxide and nitrogen system
- h) Any other piping system

1.2.2.3 HP & LP bypass system

HP & LP bypass system complete with steam and spray valves, spray control station, throttling devices, fittings, de-superheating arrangement, hydraulic power pack, solenoid valves, quick acting devices, blanking devices for steam blowing, supports, associated piping including warm up arrangement, valves, instrumentation and control hardware, electrical devices and actuators/motors etc. For LP bypass valves, the control fluid supply can be taken from the common control fluid system if it is a standard practice of the bidder.

1.2.2.4 Condensing plant

- i) Horizontal surface type condenser(s) with divided water box construction, for each unit complete with all accessories such as hotwells, valves, drains, vents, strainers, CW line expansion joints and fittings, isolating butterfly valves with matching flanges, suitable handling arrangement(s) for water box and butterfly valves, steam throw off devices for HP & LP bypass system, and with provision for installation of low pressure feed water heater (s) in the condenser neck.
- ii) Condenser air evacuation system complete with 2x100% vacuum pumps, associated motors, all accessories, associated piping, valves and fittings, specialities, duplex filter, instrumentation and control etc.
- iii) Sponge rubber ball type condenser on load tube cleaning system, separately for each half of the condenser, complete with all drives, motors and accessories, associated piping/valves, instrumentation and controls, switchgear etc.
- iv) 3x50% capacity motor driven condensate extraction pumps for each unit alongwith all accessories, drives, suction strainers, associated piping and valves, instrumentation and control etc. including one number canister drainage pumps (common for all units).
- v) Emergency DM make up system including condensate storage tank and emergency make up pumps.
- vi) Debris filters (applicable for seawater based once-through CW system and seawater cooling tower based CW system) complete with strainer, interconnecting pipes, valves, actuators, control panel, switchgear and other accessories.



1.2.2.5 Feed water heating plant

Complete regenerative feed heating system including full capacity drain cooler, low pressure heaters, deaerator and feed storage tank, high pressure heaters, all accessories, associated piping, valves, instrumentation and controls etc.

1.2.2.6 Boiler feed pumps

- i) One half capacity (1x50%) motor driven boiler feed pump for each unit complete with booster pump along with its drives, mechanical seals, flexible couplings, hydraulic coupling, gear box, common base plate, forced oil lubricating system (including oil pumps, oil tank, lube oil coolers, working oil coolers, duplex oil filters etc.), suction strainers, ON/OFF type low load re-circulation valve, mobile cradle, integral piping and valves, local instrument racks/enclosures, instrumentation and control etc. One portable compact oil purifying unit of centrifuge type per station of adequate capacity complete with all accessories shall also be provided.
- ii) 2x50% capacity steam turbine driven main boiler feed pumps for each unit complete with booster pumps, step down gear box, flexible couplings, quick disconnect coupling, mechanical seals, foundation base plates, suction strainers, ON/OFF type low load recirculation valve, mobile cradle, integral piping and valves, local gauge boards, instrumentation and control etc.
- iii) Two steam turbine drives for the turbine driven boiler feed pumps per unit complete with ESV, control valves, non return valves for single admission drives, permanent and temporary steam strainers, preferably hydraulic turning gear, hand barring device, atmospheric relief diaphragm and its vent piping, all inter connecting piping, foundation base plates, integral gland seal system, complete lube oil and control oil system including oil tank, oil coolers, duplex oil filters, vapour exhausters, 100% capacity centrifuge for each steam turbine driven pump, jacking oil system, electro-hydraulic governing system, turbine supervisory system along with all control and accessories.

1.2.2.7 Condensate polishing system

Condensate polishing system for each unit along with common regeneration facility including service vessels, regeneration vessels, resin transfer system, pumps, blowers, piping, chemical tanks, waste neutralization and disposal system, instrumentation and control etc.

1.2.2.8 PG test flow nozzle

Calibrated low Beta-ratio throat tap nozzle assembly including flow straighteners, upstream and downstream machined straight lengths for main condensate flow measurements as per ASME-PTC-6.



1.2.3 High Pressure/ Power Cycle Piping, Valves and Miscellaneous Systems/ Equipment

1.2.3.1 High pressure/ power cycle piping

Scope of supply and works for high pressure / power cycle piping system shall include the piping system as listed below.

- i) High pressure piping covering complete main steam, hot reheat and cold reheat piping between boiler and turbine nozzles, HP & LP bypass piping.
- ii) Complete auxiliary PRDS and auxiliary steam piping system.
- iii) All extraction steam pipings.
- iv) Complete feed water piping including booster pumps suction, inter connection between booster pumps and main pumps, boiler feed discharge piping upto economiser, recirculation, BFP warm up and leak off and BFP turbine exhaust piping to condenser.
- v) Spray piping system for reheater/ superheater attemperation, HP & LP bypass system and auxiliary PRDS system.
- vi) Condensate piping system.
- vii) Condenser make up water system.
- viii) Heater drains and vents piping including necessary flash tanks.
- ix) Steam drains including necessary flash tanks.
- x) Valve gland sealing piping system.
- xi) Miscellaneous line drains and vents including necessary flash tanks.
- xii) Complete safety valve exhaust piping for safety valves on steam generator, HP piping, Aux. PRDS, heaters and deaerator etc.
- xiii) Start up vents, safety valves, pneumatic relief valves (PRVs), flash tanks and all vents from the respective equipments and pipes upto a level of one meter above the boiler house/ TG building roof. Silencers shall be provided for start up vents, lowest safety valve and PRVs. All drains from respective equipments and pipelines shall be connected to the drain manifold of the flash tanks.
- xiv) Complete chemical dosing system piping.
- xv) Any other piping system to make the power cycle piping complete.



- xvi) Complete steam blowing and chemical cleaning of piping including provision of temporary piping as required.

Piping systems shall be complete with fittings/accessories, specialities, blow-down valves, vent valves, drain valves and safety valves along with their escape piping, drain piping and steam traps, expansion joints, insulation, hangers, supports, restraints/guides, snubbers and auxiliary steel etc. The drain system shall be complete alongwith drain pipes, unit flash tank, drain valves, root valves, relief/safety valves, control valves, motorised valves, gate/ globe valves, non return valves, break-down orifices, steam traps etc.

1.2.3.2 Power cycle control valves

All the control valves as required, complete with pneumatic actuators and accessories, which shall include but not be limited to the following:

- i) Desuperheating spray water control valves for superheater, reheater and auxiliary steam supply
- ii) HP heaters normal and emergency level control valves
- iii) LP heaters normal and emergency level control valves (For LP1 heater, the arrangement shall be as per manufacturer's standard practice)
- iv) BFP recirculation control valves
- v) Deaerator level control valves
- vi) Deaerator pressure control valves
- vii) Condensate recirculation flow control valves
- viii) Condenser normal make up control valves
- ix) Condenser emergency make up control valves
- x) Feed water control valves (low load)
- xi) Condensate recirculation control valve
- xii) Excess condensate dump control valve
- xiii) Deaerator overflow control valve
- xiv) Boiler continuous and intermittent blow down control valves

The power cycle control valves shall be complete alongwith suitable type of bypass valves. Each control valve shall be provided with arrangement of upstream and downstream isolation valves (hand/ pneumatically/ electrically operated). All other

control valves not specifically included above but required for completeness of the system shall also be in the scope of the bidder.

1.2.3.3 Equipment cooling water (ECW) system

Equipment cooling water system complete with DM cooling water pumps, tanks, heat exchangers, NaOH dosing system, secondary cooling water pumps, self cleaning filters, interconnecting pipes, all accessories, valves, fittings, hangers and supports for cooling of turbine- generator and auxiliaries as well as steam generator auxiliaries.

1.2.3.4 Chemical dosing system

- i) High pressure chemical dosing systems (phosphate dosing) for boiler water including tanks, transfer pumps, measuring tanks, mixing/ preparation tanks, metering pumps, piping, valves, instrumentation etc.
- ii) Low pressure chemical dosing systems (viz. ammonia and hydrazine) for condensate and feed water system including tanks, transfer pumps, measuring tanks, mixing/preparation tanks, bulk chemical storage tanks, metering pumps, piping, valves, instrumentation etc.

1.2.3.5 Steam and water sampling system

Complete steam and water sampling system including sampling racks, sample coolers, pressure reducing devices, piping, valves and required instruments.

1.2.3.6 Low pressure piping and valves etc.

The scope of low pressure piping including miscellaneous piping shall cover piping systems for the following services from the terminal points within the main plant area as specified elsewhere:-

- i) Condenser cooling water system
- ii) Condenser make up, boiler fill and deaerator fill systems
- iii) Equipment cooling water system
- iv) Condensate polishing system
- v) Air pre heater water washing system
- vi) HVAC make up system
- vii) Condenser on load tube cleaning system
- viii) Debris filter (applicable for sea water based CW system)
- ix) Condenser air evacuation system

- x) Drain water system
- xi) Chemical dosing system
- xii) Service water systems
- xiii) Potable/ drinking water system
- xiv) Fire water piping system
- xv) Oil storage and purification systems
- xvi) Liquid effluent system
- xvii) Any other piping system

Piping systems shall be complete with fittings/ accessories and specialities, expansion joints, all isolating and regulating/ control valves, hand operated and/or motorized/ pneumatic/ hydraulic actuators, surface painting/ protection, hangers, supports, trestles, restraints/ guides, snubbers and auxiliary steel etc as required.

1.2.3.7 Instrument air and service air distribution systems

Instrument air and service air distribution piping in boiler and TG areas complete with all accessories such as pressure regulators, filters, driers and oil separators to be suitably tapped from respective common headers.

1.2.3.8 Refractories and thermal insulation

Refractories, thermal insulation, removable metal cladding, and auxiliary material etc. shall be provided for the steam generator, steam turbine, piping, valves, equipments and support frames etc. as required.

1.2.3.9 EOT crane for main plant building and hoists for plant auxiliaries

One number EOT crane for main plant building and suitable cranes/ chain pulley blocks/ electric monorail hoists/ hand operated trolley (HOT) of adequate capacity to meet the maintenance requirement of various equipments such as pumps, fans, motors, heat exchangers, tanks as required.

1.2.3.10 Elevators

- i) Two number passenger-cum-goods elevators (3000 kg capacity), one for each steam generator.
- ii) Two number passenger lifts/ elevators (900 kg capacity) in main plant building, one for each unit.



- iii) One number passenger lift/ elevator (900 kg capacity) in service building.

The scope for the elevator shall include all items/ accessories including all electrical equipment, services etc. required to meet all design, installation, operation, safety, protection and other requirements of IS:14665 (all parts) "Electric Traction Lifts".

1.2.3.11 Air conditioning and ventilation systems

- i) Air conditioning facilities shall be provided for areas of control room, control equipment room, shift- in-charge room, Engineer's room, UPS room, analyzer room etc. in the main plant building; ESP control room; service building; and other rooms in the scope of the bidder requiring provision of air conditioning. The system shall consist of:
- a) Central chilled water type air conditioning plant for main plant building and service building
 - b) DX air conditioning plant for ESP control room
 - c) Split/ window type for other areas as required.
- ii) Evaporative type ventilation system shall be provided for main plant building with air washer units distributed along 'A' row and 'B' row of the building. Filtered and cooled air from the air washer unit shall be distributed to various areas through diffusers. The main plant building shall be provided with adequate number of roof exhausters. Unitary air filtration system using water repellent type nylon filters shall be provided for ESP and VFD control buildings as applicable. Mechanical type ventilation system using supply air fans, exhaust air fans and roof exhausters as applicable shall be provided for other miscellaneous areas such as cable vaults, electrical switch gear rooms, battery rooms, toilets, elevator machine rooms, AC plant room, DG set room etc..

1.2.3.12 Paints and painting of all equipment, piping, valves, structure etc. shall be as per the approval of purchaser.

1.2.3.13 Chemical cleaning of all equipment and systems after their erection shall be in bidder's scope.

1.2.3.14 Necessary blanking arrangements required to protect the valves and turbine internals and other auxiliaries during steam blowing shall be provided.

1.2.3.15 Access/ maintenance platforms, walkways, hand railings etc.

- i) Necessary operating/ access/ maintenance platforms, walkways, hand railings, ladders and gratings including the interconnecting platforms and galleries, as required, for deaerator, valves, equipments and accessories etc. shall be in the scope of this package.



- ii) All fixtures, embedded parts, steel embedments including fixing lugs and welding between them, foundation plates, nuts, bolts etc. for fixing all the equipments, piping on civil works and all structures required for supporting the piping shall be included in scope work of this package.
- iii) The exact requirements of the access platforms etc., depending upon the layout and location shall be as per the best engineering practice and manufacturer's design requirement and shall be subject to purchaser's approval during detailed engineering.

1.2.3.16 All the environmentally clear waste shall be suitably routed to the purchaser's storm water drainage system through drains by the bidder. All the vents to atmosphere shall be suitably led to outside the main plant building.

1.2.3.17 All oils, chemicals etc. to waste shall be routed to a common collection tanks (to be supplied by the bidder) individually identified by the purchaser for oil or any such obnoxious material which cannot be put into the plant drainage. The oil drains from the lube oil system in TG area which are collected in a common collection tanks will be transferred to drums for further disposal/reuse (as the case may be). Separate similar arrangement will be provided for the drains in control fluid system also.

1.2.4 Electrical Works

1.2.4.1 The scope of electrical works shall include complete electrical equipments and accessories required for main plant package covered in this specification, but not limited to the following :-

- i) Generators complete with its auxiliaries viz. excitation system, gas system, seal oil system and stator water cooling system etc. and neutral grounding system.
- ii) Busducts :
 - a) Generator isolated phase busducts (IPBD) between generator terminals to generator transformer and tap-off to unit auxiliary transformers.
 - b) 11kV segregated phase busducts from unit auxiliary transformers secondary terminals to unit switchgears and station transformers secondary terminals to station switchgears.
 - c) 3.3kV segregated phase busducts from 11/3.3kV auxiliary service transformers secondary terminals to 3.3kV unit switchgears.
 - d) Non-segregated phase bus-ducts from 11/0.433kV or 3.3kV/415V transformer secondaries to 415V unit switchgears.
- iii) Power transformers viz. generator transformers, unit auxiliary transformers and station transformers.



- iv) Auxiliary service transformers:
 - a) 11/3.3kV auxiliary service transformers, as required, for unit services.
 - b) 11kV/415V or 3.3kV/415V auxiliary service transformers for unit services.
- v) Switchgears:
 - a) 11kV and 3.3kV unit switchgears, as required.
 - b) 11kV station switchgears for providing 11kV supply feeders to station facilities (e.g. coal handling system, ash handling system, water system, compressed air system etc.) and tie feeders with unit switchgears, as required.
 - c) 415V unit switchgears including emergency PMCCs, as required.
- vi) All 11kV, 3.3kV and 415V motors for unit auxiliaries.
- vii) All power and control cables, as required along with cable facilities such as cable trays, racks etc. including installation of cables of main plant area.
- viii) Earthing and lightning protection system of main plant area.
- ix) 220V DC batteries, battery chargers and DC distribution boards to meet all essential unit and station services
- x) Operator work station (OWS) for control and interlocking of generator including generator auxiliary systems, generator transformer, unit auxiliary transformers, 11kV Incomers, tie feeders and outgoing transformer, supply feeders of unit and station switchgears, 3.3kV Incomers, bus-coupler feeders and outgoing transformer, supply feeders of unit switchgears and Incomers of station switchgears, 415V Incomers and bus-coupler feeders of unit and station switchgears, diesel generator. In addition, one no. 'Electrical Control Board' (ECB) with minimum control and indication facilities for various equipments as a back-up to Operator Work Station/ CRT keyboard (OWS) for both units and station supply.
- xi) The protection, relay, synchronizing and metering panels for generator, generator transformer and unit auxiliary transformers including relay test kit shall also be provided.
- xii) Electrical laboratories and testing equipments.
- xiii) Emergency DG sets including automatic main failure (AMF) panels to meet all essential unit and station services.
- xiv) Electrostatic Precipitator (Electrical)



- xv) Any other items not specifically covered but essentially required for completeness of the system.

1.2.4.2 The bidder shall provide all material, equipment and services so as to make a totally integrated and functional system together with all accessories and associated equipment ensuring safety, maintainability and reliability and shall be in compliance with all applicable codes, standards, guides, statutory regulations and safety requirements in force.

1.2.4.3 The contractor shall include in his proposal and shall furnish all equipments, devices and services which may not be specifically stated but are needed for the completeness of system/ equipments.

The details of electrical works are described in section-5 of this specification.

1.2.5 Control and Instrumentation Works

Complete control and instrumentation system as described in Section- 6 of this specification including the following:

- i) Distributed digital control monitoring and information system (DDCMIS) comprising of:
 - a) Control system of boiler, turbine & balance of plant (namely SG - C&I, TG - C&I & BOP - C&I including their respective measurement system);
 - b) Man-machine interface and plant Information system (MMIPIS);
 - c) System programming & documentation facility;
 - d) Data communication system (DCS);
 - e) Sequence of events (SOE) recording system;
 - f) Annunciation system;
 - g) Master & slave cock system
- ii) The SG-C&I part comprising of:
 - a) DDCMIS for FSSS (including burner management system, master fuel trip, mills automation, fuel oil system, secondary air damper control system), auxiliary PRDS control system, soot blower control system.
 - b) All equipment/local mounted instruments, sensing elements, switches etc. as required as well as transmitters and sensing elements for control systems for steam generators and auxiliaries.
 - c) Local gauge board/ racks



- d) Actuators for valves and dampers
- iii) The TG-C&I part comprising of:
- a) Distributed digital control monitoring and information system (DDCMIS) comprising of following control systems:
- Turbine protection system (TPS), turbine electro-hydraulic governing (EHG) system, automatic turbine run up system (ATRS), turbine stress control system (TSC), automatic turbine testing (ATT) system, gland steam pressure control and turbine oil temperature control for main turbine
 - Turbine protection system (TPS), turbine electro-hydraulic governing (EHG) system, turbine interlock and sequence control system, gland steam pressure control and turbine oil temperature control for BFP turbine
 - HP & LP bypass control system
 - Turbine-generator control system for seal oil, stator water, gas system
 - Condenser on load tube cleaning control system and debris filter control system (if applicable)
- b) Turbine supervisory system (TSS) for main turbine and BFP drive turbines.
- c) PLC based control systems for condensate polishing system, central lub oil purification system etc.
- d) All equipment/local panel mounted instruments, sensing elements, switches etc. as required as well as transmitters and sensing elements for control systems for turbine and auxiliaries,
- e) Local instrument enclosures/ racks with transmitters mounted therein
- f) Local gauge boards/ racks for main turbine, BFPs and BFP drive turbines
- g) Actuators for valves
- iv) Other SG and TG related C&I systems/equipment:
- a) Flame monitoring system
 - b) Coal feeders control and instrumentation
 - c) Electromatic safety valves
 - d) Furnace temperature probes
 - e) Acoustic pyrometer
 - f) Mill and air heater fire protection system
 - g) Furnace and flame viewing system



- h) Electronic remote drum level monitoring system
- i) Plant performance analysis, diagnosis and optimisation (PADO) software

- v) The BOP (C&I) part comprising of:
 - a) DDCMIS consisting of:
 - Analog control functions, other than those covered in SG-C&I and TG-C&I, like coordinated master control, furnace draft control, SH/RH steam temperature control, FW flow control, heaters/ deaerator/ condenser level control, auxiliary PRDS pressure & temperature control etc.
 - Binary control functions pertaining to main plant auxiliaries like FD/ ID/ PA fans, APH, BFP etc., generator auxiliary systems and electrical breakers etc.
 - b) Suitable communication link/ gate ways for monitoring various systems such as coal handling plant, CW system, water treatment plant etc.
 - c) Steam and water analysis system (SWAS)
 - d) Transmitters, sensing elements as well as secondary instruments including vibration monitoring systems and flue gas analysis systems
 - e) Control panel/ desks, local instrument enclosures/ rack
 - f) Maintenance and calibration equipment
 - g) Actuators for valves dampers
- vi) Miscellaneous items such as:
 - a) Electric power supply system
 - b) Process connection piping and erection hardware
 - c) Instrumentation cables including special cables.

1.2.6 Civil Works

1.2.6.1 The scope of Civil Works for main plant package shall include but not limited to the following:

- i) Preparation of design and construction drawings/documents
- ii) Civil and structural works including supply of all materials (inclusive of loading, unloading), fabrication, execution of work, testing etc. for all buildings, equipment and facilities in main plant area.



- iii) Excavation in soil and rock (if any), dewatering, dressing to required profile, sheet piling or shorting/strutting, backfilling around completed structures and plinth filling, disposal of surplus earth and rock
- iv) Foundations including piling, if required
- v) Concreting including reinforcement and formwork
- vi) Steel structure, fabrication and erection of all structural steel and miscellaneous steel (i.e. steel staircase, cable/pipe supports, trestles, ladders, walkways, railing, chequered plate/grating, inserts, anchor bolts, etc.),
- vii) Masonry work, plastering, painting
- viii) Un-insulated/sandwich insulated metal wall cladding
- ix) Roofing including permanent steel decking, water proofing and rain water pipes
- x) Flooring
- xi) Acid and alkali resistant lining where required
- xii) Doors/windows, ventilators including fire proof doors
- xiii) Under deck insulation, false ceiling
- xiv) Paving, gravel filling, cable trenches/ducts, covers
- xv) Water supply to buildings, gates/valves, plumbing work, toilet fittings, water coolers in all buildings
- xvi) Sewerage work
- xvii) Exhaust fans in all toilets, pantries & kitchen, lift-well,
- xviii) Damp proofing, water proofing of underground structures
- xix) Anti-weed and anti-termite treatment
- xx) Plinth protection

1.2.6.2 Plant infrastructural works

- i) Geotechnical investigations and detailed survey
- ii) Site clearance including grubbing, removing of shrubs, trees etc.
- iii) Plant leveling and grading including micro grading
- iv) Access road from nearest highway² to plant site, plant roads, access roads to various buildings/structures as required
- v) RCC culverts and concrete pipes for underground facilities
- vi) Rails for transformer yard and main plant building with RCC foundations
- vii) Fencing for transformer yard and other areas wherever required

² Distance to be indicated by purchaser.



- viii) Drainage system in main plant area including storm water drainage system upto natural drainage system
- ix) Concrete paving in main plant building area wherever required

1.2.6.3 Main plant– turbine island

- i) Main plant building (AB, BC & CD bays) with turbine floor, mezzanine floors, deaerator floor, and various facilities such as unit control room, control equipment room, MCC/ Switchgear rooms, SWAS room, battery rooms, cable vaults, air handling unit (AHU) rooms etc.
- ii) Foundations for TG and other equipment
- iii) Transformer yard
- iv) Pipe/cable rack structures including foundations
- v) Pipe and cable trenches
- vi) Concrete stools /steel structures for equipment foundation/mountings, valve operating platforms, access ladders etc.

1.2.6.4 Main plant– boiler island

- i) Boiler foundations
- ii) ESP foundations
- iii) Foundations for Boiler auxiliaries viz. fans, mills and other miscellaneous equipment
- iv) Duct support foundations
- v) Mill and bunker bay buildings
- vi) Raw coal bunkers
- vii) Pipe/cable rack structures including foundations
- viii) Pipe and cable trenches

1.2.6.5 Plant auxiliary buildings and pump houses etc.

- i) Service building
- ii) DG set building
- iii) ESP and VFD control building
- iv) Fuel oil pressurizing pump house

- v) Condensate storage tank foundations
- vi) Chemicals storage tank foundations
- vii) Waste neutralizing pit
- viii) Air conditioning plant building
- ix) Air washer rooms

The details of civil works are described in Section- 7 of this specification.

1.2.7 Spares

All the mandatory spares as specified elsewhere in the specification.

1.2.8 Erection, Commissioning and Performance Guarantee Testing

Complete erection, pre-commissioning testing, successful commissioning and performance testing.

- i) Complete pre-commissioning work including tests of facilities such as line flushing, hydraulic testing of steam generator pressure parts, air and gas tightness tests of steam generator enclosure, electrostatic precipitators and duct work, chemical cleaning of pressure parts, steam blow off, gas distribution tests of electrostatic precipitators etc. and all other tests as mutually agreed in the contractor's quality assurance programme as well as those identified in the specification.
- ii) Commissioning and initial operation of the facilities.
- iii) Supply of all consumables (except coal and fuel oil for firing) like chemicals for chemical cleaning, passivation, inhibition etc., oil for line flushing, nitrogen for blanketing, consumables for air/gas tightness tests and any other consumable as may be required for above pre-commissioning/ commissioning activities.
- iv) Supply of all temporary equipments such as tanks, piping, including supports, valves, nitrogen blanketing equipments including nitrogen cylinders, pumps and all necessary instrumentation for successful conductance of pre-commissioning and commissioning activities.
- v) The temporary equipments specifically brought by the contractor solely for the pre-commissioning and commissioning work shall, on completion of these activities, remain the property of the contractor. However, the nitrogen blanketing equipment including nitrogen cylinders shall get included in the contractor's permanent scope of supply and become property of the purchaser.



- vi) The selection of material of all the temporary equipments/instruments shall be compatible with the service conditions expected during pre-commissioning/ commissioning activities.
- vii) All temporary equipments and instruments shall be clearly listed out in the bid.
- viii) Supply of all labour, skilled/semi skilled supervisors, engineers and any other manpower.

All the erection materials and consumables like shims, welding rods, soldering and brazing alloys, insulating tapes, compounds, chemicals etc. required for the erection and commissioning work shall be in the scope of the bidder.

1.2.9 Tools and Tackles

One set of maintenance and repair tools including all special tools and tackles required for commissioning, testing, calibration, modification and maintenance of turbine generator units. These tools and tackles shall be separately packed and brought to site. These shall not be used for erection/commissioning purposes and shall be in an unused and new condition, when they are handed over to the purchaser. A list of all such special tools and tackles shall be submitted along with the offer. Following tools and tackles shall be provided as a minimum for each unit:

- A) One complete set for each unit, of all special tools and tackles for maintenance of all equipments. Each set of tools and tackles shall necessarily include but will not be limited to following:
 - i) One set of power operated gondola(s) or a furnace maintenance cradle(s) for furnace tube repairs and maintenance. This gondola/ maintenance cradles shall be suitable for complete and simultaneous coverage of all the four walls of steam generator and shall be complete with all slings etc. Steam generator shall have suitable provisions for suspending this cradle from the top.
 - ii) Special tools and tackles required for erection, testing and maintenance of pulverisers.
 - iii) General maintenance tools:
 - a) Pulling cable, eyebolts, cable slings, chaining falls, snubbing lines/ cables.
 - b) Bar and sledge hammers.
 - c) Brass and lead hammers.
 - d) Power type jacks and jacking screws.
 - e) Feeler gauges and shims.
 - f) Dial indicators.
 - g) Wire brushes and scrappers.
 - h) Bearing and coupling pullers.
 - i) Spanners and wrenches of various sizes.



- iv) Special maintenance tools:
- a) Tube expanders for heat exchangers.
 - b) Lapping plates, grinding stones and ring cap for the valves.
 - c) The burner maintenance trolley with vice, burner.
 - d) Spanners and wrenches specific to the equipment.
 - e) Trolley, drive, pedestals etc. for carrying out maintenance and overhauling for steam turbine generator
- B) Complete lifting tools and tackles. Contractor shall provide motorized hoists and trolleys for all items requiring maintenance and weighing 500 kg or more. All auxiliary structures, monorails, runway beams for all lifting tackles, hoists etc., are included in Contractor's scope of supply. Access ladders with suitable platform shall also be provided for approach to all motorized hoists/trolleys mounted on their runway beams for the maintenance of hoists/trolleys. Items weighing more than 50 kg and required to be replaced for maintenance shall be provided with manual hoists/trolleys with runway beams/supporting structure etc.
- C) One (1) set of quick erect scaffolding (common for two units) erectable inside of the Steam generator for capital overhaul.

1.2.10 Consumables, Oils and Lubricants

All the first fill and consumables such as greases, oil, lubricants, servo fluids/control fluids, gases and essential chemicals etc. required upto commercial operation for the equipment covered under the scope of this specification. Suitable standard lubricants as available in India are desired. Efforts should be made to limit the variety of lubricants to minimum.

1.2.11 All fixtures, embedded parts, steel embedments including fixing lugs and welding between them, foundation plates, grouting, nuts, bolts etc. for fixing all the equipments, piping on civil works shall be included in scope work of this package. All structures which would be required by the bidder for supporting the piping shall be included in scope of work of this package.

1.2.12 Any other item not specifically mentioned above but required for completeness and successful performance of the unit.



1.3 TERMINAL POINTS AND EXCLUSIONS

1.3.1 Terminal Points

The following terminal points are to be read alongwith the terminal points shown in the tender drawings. At interface points, matching/counter flanges and matching pieces etc. wherever required shall be supplied by the contractor (unless otherwise excluded). The list of terminal points is indicated as below:

- | | | |
|-------|------------------------------------|--|
| i) | CBD and IBD drains | Plant drain system |
| ii) | Vents | One meter above the boiler house/ main plant building roof level |
| iii) | Fuel oil facilities | Fuel oil storage tank outlet flange |
| iv) | Flue gas duct | Chimney inlet. |
| v) | Coal supply | To receive coal in bunkers from trippers (within purchaser's scope) |
| vi) | Mill rejects | Pyrite hopper outlet of each mill |
| vii) | Bottom ash | Furnace opening for bottom ash hopper |
| viii) | Fly ash | Outlet section of ash hoppers |
| ix) | Condenser cooling water | Intake and discharge CW water piping upto 1.5 meters beyond A-row columns for condenser cooling |
| x) | ECW system secondary cooling water | Intake from CW piping upstream of terminal point for condenser cooling water

Return hot water from the discharge of plate type heat exchangers to be terminated in CW piping at downstream of condenser outlet terminal point |
| xi) | D.M. water make up | DM make up near A-row, at suitable location with terminal pressure around 2 kg/cm ² (g) |
| xii) | Service water | |
| | a) Boiler area | Connection with an isolation valve at a pressure of about 5 kg/cm ² (g) near front row of boiler columns to meet the service water network of respective boiler and their auxiliaries |



- | | |
|---------------------------|--|
| b) Turbine area | Connection with an isolation valve at a pressure of about 4 kg/cm ² (g) near C-row, to meet the service water network of respective TG and their auxiliaries. |
| xiii) Instrumentation air | |
| a) Boiler area | Connection from the instrument air ring main of the respective unit at suitable location in boiler bay for further interconnection. The pressure at terminal point shall be about 6 kg/cm ² . |
| b) Turbine area | Connection from the instrument air ring main of the respective unit at suitable location in TG bay for further interconnection. The pressure at terminal point shall be about 6 kg/cm ² . |
| xiv) Service air | |
| a) Boiler area | Connection from the service air ring main of the respective unit at suitable location in boiler bay for further interconnection. The pressure at terminal point shall be about 6 cm ² . |
| b) Turbine area | Connection from the service air ring main of the respective unit at suitable location in TG bay for further interconnection. The pressure at terminal point shall be about 6 kg/cm ² . |
| xv) Liquid effluents | |
| a) Waste water | Plant drain system |
| b) Oils, chemicals | Collection tanks |
| xvi) Electrical system | |
| a) | Terminal pads of the H V. side of generator transformers and station transformers |
| b) | 11 kV station switchgear for all station facilities |

1.3.2 Exclusions

- i) Lighting system.
- ii) Fire fighting system, unless otherwise specifically indicated.
- iii) Communication system
- iv) Hydrogen generation plant
- v) Fuel oil tanks
- vi) Mill reject handling system



1.4 GENERAL TECHNICAL REQUIREMENTS

- 1.4.1 Steam generator and turbine generator unit shall be designed to produce maximum continuous output power with steam parameters of 170 kg/cm² (abs) pressure and 537⁰C/ 565⁰C temperature at the turbine inlet. The power plant shall be designed to operate on unit basis having no interconnection with other units either on the boiler feed water side or main steam side. Each generator will be connected to its own generator transformer. The unit auxiliary power requirement shall be drawn from unit auxiliary transformer tapped off the generator bus duct.
- 1.4.2 The unit shall be designed to operate satisfactorily under prevailing tropical conditions. The boiler unit shall be suitable for outdoor installation. The steam turbine generator unit shall be suitable for indoor installation on spring supported vibration isolation foundation. The turbine driven BFPs and motor driven BFP shall be installed on reinforced concrete foundations.
- 1.4.3 The unit shall be designed to operate as a base load station. However, continuous operation under two shift and cyclic modes during certain periods of the year is also envisaged. The design should cover adequate provision for quick startup and loading of the unit to full load at a fast rate and apart from constant pressure operation would also have the facility for sliding pressure operation. The design of the equipments and control system would permit participation of the machine in automatic load frequency control.
- 1.4.4 The unit shall be capable of operating on a daily cycling basis. There shall be a HP & LP bypass system to facilitate quick starting and loading under hot restart conditions and to facilitate conserving condensate where too many start ups occur. Owing to certain conditions in the system, part load operation of the machine could occur for prolonged durations. Under such conditions there shall not be any undue deterioration in the parts and the elements. The turbine unit shall be capable of deriving economic benefits due to lower temperature of circulating water and environment in winter while it shall be able to meet the MCR requirements under adverse conditions of higher temperature in summer.
- 1.4.5 The boiler, turbine- generator and associated equipment and systems shall be of proven design, using proven materials with well established physical and chemical properties and as appropriate to the service as intended.

For plant site in the coastal areas, the environment is likely to be corrosive and the materials of construction for all exposed metal/ concrete surfaces shall be so chosen as to withstand the corrosive environment. Also suitable weather protection shall be provided to all exposed surfaces. Underground piping shall be avoided to the extent possible, and suitable anti-corrosive measures shall be provided for under-ground piping where the same is absolutely necessary.



- 1.4.6 Type, make and rating of all equipment shall be subject to approval of the purchaser. Irrespective whether bidder himself is a manufacturer/supplier for equipment(s)/system(s) or sources from other manufacturers/ suppliers, the particular type of equipment/system shall be in successful operation in at least one (1) unit of 500 MW for a minimum period of one (1) year as on the date of bid opening. However, in case of minor modification to improve the capacity and performance of the equipment, the same may be agreed subject to the extended warranty of that equipment for a period of two years. To enable the approval of sub-vendors, the bidder shall provide all necessary data such as type, design, make, capacity, duty conditions, date of commissioning/commercial operation, contact phone numbers, e-mail addresses etc.
- 1.4.7 The unit and the auxiliaries shall be designed for maximum reliability and availability; operability and maintainability. The bidder shall specifically state the design features incorporated to achieve the high degree of reliability and availability.
- 1.4.8 Adequate maintenance facilities shall be provided as required, for assembly, disassembly, handling during maintenance and alignment work of all important equipments and auxiliaries viz: mills, fans, air preheaters, burners, dampers steam turbine casing (inner and outer), diaphragm glands, steam valves, journal/thrust bearings, turbine rotors, generator rotor, end rings, shaft seals, generator bearings, hydrogen coolers, condenser water box, vacuum pumps, CEPs and BFP cartridges, BFP drive turbines, regenerative feed water heaters, turbine oil coolers, pumps etc.
- 1.4.9 Complete thermal, mechanical and electrical functions of the station are to be remotely controlled from the unit control desk/ Panel (located in common control room) during normal as well as emergency operating conditions. The bidder shall supply distributed digital control, monitoring and information system (DDCMIS) covering complete unit.
- 1.4.10 The turbine generator shall comply with general requirements and standards of latest versions of IEC-45 and 46, IEEE-122, IEC-34-1, IEC-34-3 or their approved equivalents subject to approval of purchaser. All pumps shall comply with the latest applicable recommendations of Hydraulic Institute Standards (U.S.A) or approved equivalents.
- 1.4.11 The unit shall be suitably designed and provided with necessary instrumentation for rapid starting, loading and unloading without causing undue vibration, distortion, differential expansion or producing excessive thermal stresses. The design of the control system and relevant equipment shall adhere to the fail safe operation at all system conditions. The fail safe operation signifies that loss of signal/air/power supply, loss of excitation or failure of any component will not cause hazardous conditions and at the same time prevent occurrence of false trips.
- 1.4.12 Wherever oil coolers of any equipment are provided, these shall be of 3x50% or 2x100% capacity to facilitate cleaning without shutting down the equipment. All coolers/jackets shall be designed to take care of the operating pressure of the cooling medium.
- 1.4.13 All stand-by auxiliaries shall be designed for auto start up, on failure of running auxiliaries with minimum time delay and without runback on unit load.
-



- 1.4.14 All equipment, systems and works covered under these specifications shall be in accordance with all the latest applicable statutes, regulations, codes and standards specified as well as all such standards, statutes, regulations and safety codes applicable in the locality where the equipment will be installed. Bidders may familiarize themselves with all such requirements before preparation of bids. Complete design including pressure parts, piping, valves and fittings shall meet or exceed all the requirements of the latest versions of Indian Boiler Regulations (IBR), Indian Standards /ASME codes. It shall be the responsibility of the bidder to take all approvals required and get the boiler registered under the IBR. In all other cases where IBR does not govern, IS/ASME, Japanese, American, British, German or other international standards established to be equivalent or superior to IS/ASME shall be acceptable with the approval of the purchaser at the time of detailed engineering. In the event of any conflict between the requirements of equivalent codes and standards, and the requirements of IBR, the latter shall govern unless specified elsewhere in the specifications.
- 1.4.15 The work falling under the purview of Indian Boiler Regulations (IBR) shall completely meet or exceed all the requirements of the latest edition of IBR. Any other standard acceptable to IBR can also be considered, provided the requirements of that standard are equivalent or exceed IBR requirements.
- 1.4.16 The responsibility of safe, efficient and reliable operation of the equipment and system supplied shall rest on the supplier and the approval of the drawings/documents shall not in any way relieve the manufacturer of this and obligation to meet all the requirements stipulated in the specification or of the responsibility for correctness of the drawings/documents.
- 1.4.17 It shall be the responsibility of the contractor to furnish the requisite documentation as required by the purchaser/consultant for ascertaining the adequacy of the design/soundness of the materials of construction /manufacturing methods adopted etc.
- 1.4.18 All materials used for the construction of the equipment shall be new and shall be in accordance with the requirements of this specification. Materials utilised for various components shall be those which have been established for use in such applications. It would be the responsibility of the bidder to furnish the relevant information in this regard, as required, at the time of detailed engineering.
- 1.4.19 All heavy parts of the plant must be provided with some convenient arrangement for aligning and for handling during erection and overhaul. Any item of plant required to be stripped or lifted during period of maintenance and weighing one tonne or more shall be marked with its approximate weight. All equipment shall be designed to run satisfactorily without any undue noise and vibrations. Corresponding parts throughout shall be made to gauge and shall be interchangeable wherever possible. No welding, filling or plugging of defective parts shall be allowed without the permission in writing of the purchaser.



- 1.4.20 Each main and auxiliary item of plant shall have permanently attached to it in a conspicuous position, a rating plate of non-corrosive material upon which shall be engraved manufacturer's name, equipment, type or serial number together with details of the ratings, service conditions under which the item of plant in question has been designed to operate, and such diagram plates as may be required by the Engineer. The inscriptions on the name plates as also the material and design of the name plates shall be approved by the Engineer.
- 1.4.21 The bidder shall endeavor to supply the equipment (motors, valves, actuators, instruments etc.) of same type and make to the extent possible so as to reduce the spare parts inventory. However, this must not affect the functioning and operational reliability of the given equipment.
- 1.4.22 Noise level should not be more than 85 dBA at a distance of 1 meter and at a height of 1.5 meter from any equipment except for TG, HP & LP bypass valves, air motors, safety valves and regulating drain valves. The noise level for TG, regulating drain valves and for air motors shall not exceed 90 dBA and 95 dBA respectively, and that for safety valves and associated vent pipes shall not exceed 105 dBA. Noise level of HP & LP bypass valves shall not exceed 115 dBA during valve operation. If necessary, suitable noise reduction covers shall be provided. Compliance to noise level shall be demonstrated by the bidder.
- 1.4.23 All the electric motor driven equipments shall give their rated performance even at a power supply frequency of 47.5 Hz (minimum). All equipments and auxiliaries shall be suitable for continuous operation in the frequency range of 47.5 Hz to 51.5 Hz.
- 1.4.24 The plant and it's units shall be designed to operate with all the specified margins for continuous operation without any limitations under any of the conditions indicated in the Technical Specification.



1.5 LAYOUT CONSIDERATIONS

The broad salient features of the layout arrangements of various equipment in the main plant building housing the turbine- generator and its auxiliaries and steam generator area are given as hereunder.

- (i) The arrangement of the turbine- generator in the main plant building shall be of longitudinal type. The boiler centre line shall be the same as that of TG condenser as far as possible. Unit pitching distance between centre lines of two boilers shall be approximately 120m. The column spacing of main plant building may be about 10 m.
- (ii) The conventional arrangement of AB, BC and CD longitudinal bays with D row as first row of boiler columns should preferably be adopted with their respective widths of about 30m, 10m and 11m. The mill bunker buildings shall be about 12m wide on each side of the boiler.
- (iii) Two transverse bays at 0.0 m elevation equivalent to minimum area of 700m² shall be provided for unloading and maintenance at one end of main plant building. One additional bay shall be provided between two units for maintenance at ground floor. Alternatively, two transverse bays may be provided between two units for unloading and maintenance with one bay on either end of the building for maintenance at ground floor. Further, a minimum lay down area of 600 m² per unit with EOT crane approach shall be kept on the operating floor.
- (iv) The location of control room (common for two units) shall be in BC bay at the operating floor level. Adjoining the control room, there shall be a control tower which shall accommodate control equipment room, AC plant room, battery room and UPS for C&I system, cable vault etc. at its different floor levels.
- (v) There shall be no regular basement floors in main plant building and mill bunker bay building. Also the local pits/trenches in main plant building/ mill bunker bay building/ boiler/ ESP area are to be avoided as far as possible.
- (vi) The dearator shall be located in the BC bay at an appropriate elevation so as to meet the NPSH requirement of boiler feed pumps. Horizontal HP heaters and LP heaters shall also be located in BC bay with space provision for tube withdrawal.



- (vii) Clear walk ways of minimum 1.5 m width at all the levels shall be provided in the main plant building. For interconnection with service building, walk way of about 3.5 m width shall be provided along 'B' row of main plant building. Adequate fire escape staircases shall be provided in main plant building with fire doors at each landing.
- (viii) Through walkways of minimum 1.5 m width shall be provided along A-row columns at ground floor and operating floor. For EOT crane maintenance, through walkway shall be provided along both rails at crane girder level. Approach to the crane through rung ladders shall be provided at least at two places.
- (ix) Interconnecting walkways (minimum 2.0m clear) shall be provided between main plant building and boiler on either side of boiler at three elevations viz. mezzanine, operating and deaerator floor levels. Two nos. walkways each shall be provided on either side of the boiler between boiler and mill bunker building at feeder floor level, tripper floor level and roof of mill bay.
- (x) The layout arrangement of critical piping connecting the steam generator and steam turbine shall be developed in such a way as to optimize the use of materials and resulting in minimum pressure losses in the steam flow.
- (xi) Steam turbine, generator, BFPs and other equipments located in the turbine hall shall be accessible by the EOT cranes for their handling during maintenance and overhauling. For all other equipment/ components located in the main plant building, suitable handling arrangement viz. cranes/ chain pulley blocks/ monorail hoists etc. as required shall be provided for the maintenance and overhauling. Wherever special handling procedures are to be followed, the same shall be described in a separate document.
- (xii) Facility shall be provided for handling of condenser water box to enable maintenance and withdrawal of condenser tubes. Rolling shutter(s) between 'A' row columns alongwith extended platform shall be provided to facilitate condenser tube withdrawal.
- (xiii) In the boiler area, facility of crane/ chain pulley block/ monorail hoist etc. shall be provided along with provision of space for maintenance/ overhauling of equipment such as mills, coal feeders, boiler circulation pumps, fans, motors, and handling of APH baskets and coils of economizer and SCAPH etc.



- (xiv) Layout of facilities and equipment shall allow removal of generator transformers, station transformers and unit auxiliary transformers without disturbing structure, equipment, piping, cabling, bus ducts etc. routed in the area. Suitable rail track and associated facilities like jacking pads, anchor blocks etc. shall be provided to facilitate the movement of generator transformers, station transformers and unit auxiliary transformers to the maintenance bay. These rail tracks shall be accessible from the equipment unloading area of AB bay by a rail track.
- (xv) Clear approach width of minimum 10m with 8m clear height shall be provided at the front and rear of ESP.
- (xvi) The VFD control equipment and transformers for radial type ID fans, if provided, shall be located along with the ESP control equipment in the ESP control room.
- (xvii) Location and height of the transfer points (TP) for coal conveyors to be provided by coal handling plant supplier shall be decided during detailed engineering. Coal shall be supplied upto the bunkers of the plant which are in the scope of this specification.
- (xviii) Trestles to be provided for routing of cables, pipes etc. shall have a clear height of 8.0m at road crossings so as to clear the road spaces, approach to maintenance bays of different equipment. A walkway with hand rails and toe guards of 750mm (minimum) width shall be provided all along length of the trestle for maintenance of cables and pipes. Ladders for approach to these platforms shall be provided near roads, passage ways.
- (xix) Floor drains shall be provided at all floors and drain discharge pipes shall be properly sized taking into account the fire water sprinkler system wherever provided.
- (xx) Valves shall be located in accessible positions. All piping shall be routed at a clear height of minimum 2.5 m from the nearest access level for clear man movement. Best engineering practices shall be adopted for keeping the minimum clear working space around equipment and clear headroom within main structures and cable trays etc.
- (xxi) Fire water pipes in main plant area may be routed in trenches filled with sand and covered with pre-cast RCC covers.



- (xxii) The safety requirements as per the Factories Act, Indian Electricity Rules and other applicable codes/standards etc. shall be observed while developing the layout.
- (xxiii) Ventilation fans on AB bay roof shall be staggered and shall not be near the centre line of turbine-generator set. Air washer room could be located at outside TG bay on 'A' row side and in BC bay on 'B' row side.

The suggestive layout details of the plant are indicated in the enclosed drawings as listed below. However, the bidder may suggest his own layout arrangement which shall be subject to approval of the purchaser.

- a) Plot Plan Drawing.³
- b) Drawing No. CEA- TE- STD- A- 001 titled, “Main Plant Layout Plan at 0.0 m.”
- c) Drawing No. CEA- TE- STD- A- 002 titled, “Main Plant Equipment Layout Plan at Different Elevations.”
- d) Drawing No. CEA- TE- STD- A- 003 titled, “Main Plant Cross- Section.”

³ Plot plan drawing indicating main plant area to be enclosed by the purchaser.



1.6 PERFORMANCE GUARANTEES

1.6.1 General Requirements

- i) The contractor shall guarantee that the equipment offered shall meet the ratings and performance requirements stipulated for various equipment covered in these specifications.
- ii) The guaranteed performance parameters furnished by the bidder in his offer, shall be without any tolerance values and all margins required for instrument inaccuracies and other uncertainties shall be deemed to have been included in the guaranteed figures.
- iii) The Contractor shall demonstrate all the guarantees covered herein during functional guarantee/acceptance test. The various tests which are to be carried out during performance guarantee/acceptance test are listed in this Sub-section. The guarantee tests shall be conducted by the contractor at site in presence of purchaser on each unit individually.
- iv) All costs associated with the tests shall be included in the bid price.
- v) In case during tests it is found that the equipment/system has failed to meet the guarantees, the contractor shall carry out all necessary modifications and/or replacements to make the equipment/system comply with the guaranteed requirements at no extra cost to the purchaser. However, if the contractor is not able to demonstrate the guarantees, even after the above modifications/replacements within ninety (90) days or a reasonable period allowed by the purchaser, after the tests have been completed, the purchaser will have the right to either of the following:

a) For Category-I Guarantees

Reject the equipment/ system/ plant and recover from the contractor the payments already made

OR

Accept the equipment/system/plant after levying liquidated damages (LDs) as specified hereunder. The liquidated damages for shortfall in performance indicated in clause 1.6.2.3 for this sub-section shall be levied separately for each unit. The rates indicated in clause 1.6.2.3 of this sub-section are on per unit basis. The liquidated damages shall be prorated for the fractional parts of the deficiencies. The performance guarantees coming under this category shall be called 'Category-I Guarantees'.

b) For Category-II Guarantees

Reject the equipment/ plant/ system and recover from the Contractor the payments made. The performance guarantees under this category shall be called 'Category-II Guarantees'. Conformance to the performance requirements under Category-II is mandatory.



c) For Category-III Guarantees

Reject the equipment/system and recover from the Contractor the payments already made.

OR

Accept the equipment/system after assessing the deficiency in respect of the various ratings, performance parameters and capabilities and recover from the contract price an amount equivalent to the damages as determined by the purchaser. These parameters/ capacities shall be termed as 'Category- III Guarantees'.

1.6.2 Guarantees under Category- I

1.6.2.1 The performance guarantees which attract liquidated damages are as follows:

- i) Steam generator efficiency
 - a) Efficiency of the steam generator at 100% TMCR and 27°C ambient temperature and 60% RH while firing the design coal at rated steam parameters, rated coal fineness and rated excess air.
 - b) Efficiency of the steam generator at 80% TMCR and 27°C ambient temperature and 60% RH while firing the design coal at rated steam parameters, rated coal fineness and rated excess air.
- ii) Steam generating capacity

Steam generating capacity in kg/hr. of steam at rated steam parameters at superheater outlet (with any combination of mills working as per purchaser's discretion) with the coal being fired from within the range specified under this subsection.
- iii) Turbine cycle heat rate
 - a) Turbine cycle heat rate in kcal/kWh under rated steam conditions at design condenser pressure with zero make up at 100% TMCR load.
 - b) Turbine cycle heat rate in kcal/kWh under rated steam conditions at design condenser pressure with zero make up at 80% load.
- iv) TG output

Continuous TG output of 100% TMCR under rated steam conditions at design condenser pressure with 3% make up.
- v) Auxiliary power consumption
 - a) Auxiliary power consumption at 100% TMCR unit load.

The total auxiliary power consumption for all the auxiliaries of boiler, turbine- generator, and the equipments of turbine cycle included in this package required for continuous unit operation at TMCR load under rated steam conditions and at design condenser pressure with 0% make up and with ambient air temperature of 27°C and RH of 60% shall be guaranteed in line with the requirements stipulated in clause 1.6.2.4 of this sub-section.



b) Auxiliary power consumption at 80% TMCR unit load.

The total auxiliary power consumption for all the auxiliaries of boiler, turbine- generator, and the equipments of turbine cycle included in this package required for continuous unit operation at 80% TMCR load under rated steam conditions at design condenser pressure with 0% make up and with ambient air temperature of 27 deg. C and RH of 60% shall be guaranteed in line with the requirements stipulated in clause 1.6.2.4 of this sub-section.

vi) Pressure drop across condenser

Pressure drop across bidder's terminal points for condenser cooling system with on line condenser tube cleaning system in operation

Note: Power consumption of each of the driven auxiliary shall be measured with its own drive.

1.6.2.2 Bidder shall quote the steam generator efficiency (by loss method) as per the requirements of BS EN 12952- 15, 2003 code (reaffirmed latest) and other specification stipulations. The guaranteed efficiency quoted by the bidder shall comply with following limiting parameters with design coal firing:

- i) Excess air at economizer outlet : 20% (min.) (at TMCR load)
- ii) Corrected flue gas temperature : 125 °C or as predicted by the bidder at air preheater outlet whichever is higher (at TMCR load)

Bidder to note that no credit shall be given in the bid evaluation or in the evaluation of the results of the guarantee tests for performance predictions/ guarantees etc. if the values considered by the bidder for parameters indicated at (i) & (ii) above are lower than those specified above.

1.6.2.3 Amount of liquidated damages (LD) applicable for Category- I Guarantees

If the guarantees specified at clause no.1.6.2.1 are not achieved by the contractor within 90 days or a reasonable period allowed by the purchaser after notification by the purchaser, the purchaser may at his discretion reject the equipment/system and recover the payment already made or accept the equipment/system only after levying liquidated damages listed herein against the contractor and such amounts shall be deducted from the contract price:

<u>S.No.</u>	<u>Guarantee</u>	<u>Amount of LD⁴</u>
--------------	------------------	---------------------------------

i) **Steam generator efficiency**

For shortfall in guaranteed steam generator efficiency in percentage while firing design coal at rated steam parameters, rated coal fineness and rated excess air and other

⁴ Amount of LDs to be worked out for specific project by the purchaser.



stipulated conditions at:

- a) 100 % TMCR unit load
- b) 80 % TMCR unit load

ii) Steam generator capacity

For shortfall in the guaranteed steam generating capacity in T/hr of steam at rated parameters at superheater outlet (with any combination of mills working as per purchaser's choice), the coal being fired from within the range specified.

iii) For increase in the guaranteed turbine cycle heat rate

- a) At 100% TMCR unit load
- b) At 80% TMCR unit load

iv) For deficiency in turbine generator output

v) Auxiliary power consumption

- a) Auxiliary power consumption at 100 % TMCR unit load

For increase in the auxiliary power consumption in kW guaranteed as per the requirements of clause 1.6.2.1 (v) (a) of this sub-section

- b) Auxiliary power consumption at 80 % TMCR unit load

For increase in the auxiliary power consumption in kW guaranteed as per the requirements of clause 1.6.2.1 (v) (b) of this sub-section

vi) For increase in pressure drop across condenser cooling system

Notes: i) Each of the liquidated damages specified above shall be independent and these liquidated damages shall be levied concurrently as applicable. contractor's aggregate liability to pay liquidated damages for failure to achieve the performance guarantees shall not exceed twenty five percent (25%) of the contract price.

- ii) If the performance shortfall is such that the performance shortfall exceeds two (2) percent of the guaranteed value then the purchaser will be entitled (at the purchaser's sole discretion) to reject the works, terminate the

contract, and recover from the contractor any loss the purchaser has suffered. The purchaser will give credit for any part of the works which he retains. In case, the plant is rejected by the purchaser, the price recovery from the Contractor will be done upto the maximum of contract price.

1.6.2.4 Auxiliary Power Consumption

The auxiliary power consumption shall be calculated using the following relationship:

$$P_a = P_{tg} + T_L$$

P_a = Guaranteed auxiliary power consumption

P_{tg} = Power consumed by the auxiliaries of the unit under test

T_L = Losses of the transformers

While guaranteeing the auxiliary power consumption, the bidder shall necessarily include all continuously operating auxiliaries. The auxiliaries to be considered shall include but not be limited to the following:

- i) Mills.
- ii) PA fans.
- iii) FD fans.
- iv) ID fans.
- v) Air heaters.
- vi) Coal feeders.
- vii) Boiler water circulation pumps.
- viii) Seal air fans.
- ix) Lube oil pumps for fans/ air heaters and mill system etc.
- x) Scanner air fans.
- xi) Electrostatic precipitator (with T.R sets and hopper heaters of all ESP fields in service, insulator heater of all ESP fields/ pent house fan (as applicable) and rapping system under normal operation).
- xii) Condenser air evacuation pumps
- xiii) Condensate extraction pumps
- xiv) Condenser tube cleaning system pumps
- xv) Lube oil pumps of 2x50% TDBFPs
- xvi) Auxiliary oil pump for MDBFP
- xvii) Oil pumps for HP & LP bypass system



- xviii) DM cooling water pumps to supply cooling water on the primary (DM) side of the PHEs for boiler and turbine auxiliaries in the closed loop ECW system
- xix) Secondary cooling (normally working) water pumps to supply cooling water on the secondary side of the plate type heat exchangers in the closed loop equipment cooling water system
- xx) Unit lub oil purification system including heaters, feed and discharge pumps
- xxi) Unit control oil purification system
- xxii) Oil purifiers of 2x50% TDBFPs including their heaters, feed and discharge pumps
- xxiii) Chemical dosing pumps
- xxiv) Air conditioning and ventilation system
- xxv) Battery charger and UPS
- xxvi) Power consumption of any other continuously operating auxiliary and equipment for unit operation.

1.6.2.5 Heat Rate

Turbine Cycle Heat Rate shall be calculated as follows and indicated in all computed heat balance diagrams:

$$\text{Heat Rate} = \frac{M1(H1-h1)+M2(H3-H2) + Mis (h1-his) + Mir (H3-hir)}{Pg}$$

Where,

M1 = Quantity of live steam entering the turbine stop valve including any live steam supplied to valve stems, or glands etc. in kg/hr.

M2 = Quantity of steam from turbine to reheater in kg/hr.

Mis = Quantity of de-superheating water flowing into superheater system for regulation of steam temperature in kg/hr

Mir = Quantity of de-superheating water flowing into re-heater system for regulation of steam temperature in kg/hr

H1 = Enthalpy in kcal/kg of live steam

H2 = Enthalpy in kcal/kg of steam to reheat

H3 = Enthalpy in kcal/kg of reheated steam

h1 = Enthalpy of feed water in kcal/kg at the downstream of the junction of feed flow and bypass flow of HP heaters

his = Enthalpy of de-superheating water flowing into superheater system in kcal/kg

hir = Enthalpy of de-superheating water flowing into re-heater system in kcal/kg



P_g = Electrical power generated at generator terminals (in kW) less the following:

- a) Power taken by excitation system (kW)
- b) Power required for ventilation of oil and control fluid tanks, if ventilating fans are separately driven (kW).
- c) Power required for lubrication, if lub oil pumps are separately driven (kW).
- d) Power required for control fluid pumps, if control fluid pumps are separately driven (kW).
- e) Power required for generator cooling and, seal oil auxiliaries, if separately driven (kW).
- f) Power required by turbine gland steam exhauster, if driven separately (kW)

- Note:
- i) Heat balance diagrams for guarantee conditions shall indicate the quantities of water for super heater and re-heater spray, as applicable.
 - ii) The term Mis (h1-his) shall not be applicable in case desuperheating water for superheaters is taken from downstream of top HP heater.

1.6.3 Guarantees under Category-II

NO_x Emission: Bidder shall guarantee that maximum total NO_x emission from the unit will not be more than 260 grams of NO_x per giga joule of heat input (from thermal as well as fuel) to the boiler during the entire operating range of steam generator for the range of coals specified. The emission shall be measured during Steam generating capacity test. The bidder shall furnish the methodology of measurement and demonstration of variations w.r.t. load upto 50% of total load.

1.6.4 Guarantees under Category-III

The parameters/ capabilities to be demonstrated for various systems/equipments shall include but not be limited to the following:

i) **Start up (for one unit only)**

Start-up time (upto full load), and loading capabilities for the complete unit (Boiler, Turbine and Generator together) set for cold start conditions (greater than 72 hours shutdown), warm start conditions (between 10 and 72 hours shutdown) and hot start conditions (less than 10 hours shutdown) as indicated by the Contractor in the offer and accepted by the purchaser shall be demonstrated, ensuring that the various turbine operational parameters like vibration, absolute and differential expansion, eccentricity and steam metal temperature mismatch etc. are within design limits.

ii) **Sudden total loss of external load**

On occasions, the steam turbine generator unit may experience sudden total loss of all external load. Under these conditions, the steam turbine generator unit shall not trip on over speed but shall continue to be in operation under the control of its speed governor to supply power for the plant auxiliary load while staying within the agreed limits of steam metal temperature mismatch, exhaust hood



temperature, absolute and differential expansion, vibration and eccentricity. The same shall be demonstrated.

iii) **Run back capabilities**

The contractor shall demonstrate automatic runback capability of the unit (boiler-turbine-generator) on loss of critical auxiliary equipment (such as tripping of one ID fan/ FD fan/PA fan/ airheater / BFP/ CEP etc.) ensuring smooth and stable runback operation.

iv) **Rate of change of load and sudden load change withstand capability**

The contractor shall demonstrate capability of boiler-turbine-generator in regard to ramp rate and step load change as specified.

v) **Noise**

All the plant, equipment and systems covered under this specification shall perform continuously without exceeding the noise level over the entire range of output and operating frequency.

Noise level measurement shall be carried out using applicable and internationally acceptable standards. The measurement shall be carried out with a calibrated integrated sound level meter meeting the requirement of IEC 651 or BS 5969 or IS 9779.

Sound pressure shall be measured all around the equipment at a distance of 1.0 m horizontally from the nearest surface of any equipment/machine and at a height of 1.5 m above the floor level in elevation.

A minimum of 6 points around each equipment shall be covered for measurement. Additional measurement points shall be considered based on the applicable standards and the size of the equipment. The measurement shall be done with slow response on the A-weighting scale. The average of A-weighted sound pressure level measurements expressed in decibels to a reference of 0.0002 micro bar shall not exceed 85 dBA except for:

- a) Safety valves and associated vent pipes for which it shall not exceed 105 dBA.
- b) Regulating drain valves in which case it shall be limited to 90 dBA.
- c) TG unit in which case it shall not exceed 90 dBA.
- d) For HP and LP bypass valves the sound level will be restricted to 115 dBA during the valve operation. However, the bidder shall make efforts to reduce the noise level to possible practicable limits.
- e) For air motors it shall not exceed 95 dBA.

Corrections for background noise shall be considered in line with the applicable standards. All the necessary data for determining these corrections in line with the applicable standards shall be collected during the tests.



vi) **Mill capacity at rated fineness**

Performance testing shall be done on each mill toward establishing its capacity specified at the rated fineness, applying corrections for the variation in coal characteristics i.e., HGI (Hardgrove Grindability Index) and moisture.

The bidder shall guarantee a capacity output not less than the offered value for each mill with following conditions occurring simultaneously during testing:

- a) Coal fineness : Not less than 70% through 200 mesh and
: Not less than 98% through 50 mesh screen
- b) Coal quality : All available coal from the specified range

Bidder shall guarantee that the above capacity will be maintained and demonstrated with the originally installed grinding elements in nearly worn-out condition as mutually agreed for the purpose of ascertaining wear life of any of the wear parts. During the above mentioned operating period of the mill, manufacturer's operating instructions will be followed and mill will be operated with the specified range of coals without any such readjustment that requires a shutdown of the mill or reduction of the load and/or any replacement of any mill wear parts.

For the purpose of testing to demonstrate the capacity, if HGI and total moisture vary from those given in coal characteristics, the above pulveriser measured capacity shall be corrected using the capacity correction curves furnished by the Contractor and approved by the purchaser. HGI versus mill capacity curve shall be furnished for HGI variation upto a value above which the capacity remain constant. Capacity guarantee shall be conducted and demonstrated on each coal pulveriser individually.

vii) **Life of mill wear parts**

Life of mill wear parts, in hours of operation, for the entire range of coal characteristics specified shall be demonstrated.

viii) **Electrostatic Precipitator**

- a) The contractor shall guarantee that the particulate emission from ESP shall not be more than 45 mg/Nm^3 under guarantee point condition at TMCR load with design coal firing. The corresponding ESP efficiency shall be worked out as per the procedure outlined at clause 1.6.5.3 of this section.
- b) The Contractor shall demonstrate that the ESP air in leakage shall not be more than 1% of total gas flow at ESP inlet at the guarantee point condition.
- c) The Contractor shall demonstrate that the maximum pressure drop through the ESP at the guarantee point flow condition does not exceed 20 mmwc.



- d) The Contractor shall demonstrate the gas distribution in the various stream and fields.
- ix) **No fuel oil support shall be required above 40% BMCR load**
- The contractor shall guarantee that oil support for flame stabilization shall not be required beyond 40% of BMCR load when firing the coals from the range identified. The Contractor shall demonstrate that with any combination of mills/ adjacent mills in service (to purchaser's choice), the steam generator does not require any oil firing for stable and efficient boiler operation at and above 40% BMCR loads. The specific constraint, if any, for achieving the above requirement shall be brought out by the bidder in the offer.
- x) **Fuel oil preparation and firing system**
- The contractor shall demonstrate that fuel oil preparation and firing system can support load carrying capacity of 30% BMCR.
- xi) **Performance characteristics of fans**
- The contractor shall demonstrate the performance characteristics of FD, ID and PA fans including their capacity, head developed, power consumption and margins envisaged on capacity and head.
- xii) **Steam temperature imbalance**
- The Contractor shall demonstrate that at SH and RH outlets (in case of more than one outlet) the temperature imbalance between the outlets does not exceed 10° C under all loads including transients.
- xiii) **SH and RH attemperation system**
- The Contractor shall demonstrate that the spray water flow of SH attemperation system does not exceed 8% of main steam flow, at superheater outlet, while firing any coal from within the range specified with HP heaters in service while maintaining the rated SH outlet steam temperature at all loads upto and including BMCR. The Contractor shall also demonstrate that the RH temperature is maintained at the rated value without any spray water requirement for the secondary attemperation system, under conditions specified in the technical specification.
- xiv) **Furnace exit gas temperature (FEGT)**
- Contractor shall demonstrate that maximum furnace exit gas temperature (FEGT) shall be minimum 60 deg C below the minimum initial deformation temperature (IDT) of ash.
- xv) **Life of coal and oil burners**
- Life of coal and oil burners as specified in hours of operation shall be demonstrated by the contractor.



xvi) **Air heater air in leakage**

Contractor shall demonstrate that the air-heater air-in-leakage and maximum drift in air leakage do not exceed the specified value.

xvii) **Steam generating capability with HP heaters out**

Contractor shall demonstrate steam generating capacity of steam generator when one and/or both or all strings of HP heaters are out of service, as offered. The metal temperature margins over the design value shall also be demonstrated for the most adverse operating conditions.

xviii) **Steam purity test**

Steam purity parameters, as envisaged in the contract, shall be demonstrated at boiler outlet.

xix) **Equipment cooling water system**

- a) Inlet and outlet temperatures on the primary and secondary side of the plate type heat exchangers shall be demonstrated at site.
- b) Parallel operation, vibration, and noise level of primary side DMCCW pumps and secondary side cooling water pumps shall be demonstrated at site.

xx) **Turbine-generator set capability**

The steam turbine generator shall be capable of delivering at generator terminals the output as indicated by the bidder in the heat balances submitted along with his bid under the following conditions:

- a) Continuous TG output of 100% TMCR under rated steam conditions at 89 mm Hg (abs)⁵ worst condenser pressure with 3% make up.
- b) Continuous output at generator terminals corresponding to VWO condition under rated steam conditions at design condenser pressure and 3% make up.
- c) Maximum continuous output at generator terminals corresponding to one string of HP heater out of operation under rated steam conditions at design condenser pressure and 3% make up.
- d) Maximum continuous output at generator terminals corresponding to both strings of HP heaters out of operation under rated steam conditions at design condenser pressure and 3% make up.

Note: While conducting the tests of (a) to (d) above the condenser pressure measurement shall be done at 300 mm above the top row of condenser tubes.

⁵ 70 mm Hg (abs) for sea water based once-through type CW system

xxi) HP & LP bypass capabilities

The HP & LP bypass system should satisfy the following functional requirements under automatic interlock action. It should come into operation automatically under the following conditions:

- a) Generator circuit breaker opening
- b) HP & IP stop valves closing due to turbine tripping
- c) Sudden reduction in demand to house load

Under all these conditions, while passing the required steam flows as per the relevant heat balances, the condenser should be able to swallow the entire steam without increasing the exhaust hood temperature and condenser pressure beyond the maximum permissible value indicated by the bidder in his offer and accepted by the purchaser. The same shall be demonstrated.

xxii) Steam condensing plant

- a) The value of design condenser pressure to be measured at 300 mm above the top row of condenser tubes shall be guaranteed under VWO condition, 3% make-up, design C.W. inlet temp. and C.W. flow. The condenser vacuum shall be measured with a vacuum grid utilising ASME basket tips.
- b) Temperature of condensate, at outlet of condenser, shall not be less than saturation temperature corresponding to the condenser pressure at all loads.
- c) Oxygen content in condensate at hotwell outlet shall not exceed 0.015 cc/litre over 50-100% load range and shall be determined according to calorimetric Indigo-Carmine method.
- d) Air leakage in the condenser under full load condition shall not exceed more than 50% of design value taken for sizing the condenser air evacuation system.
- e) When one half of the condenser is isolated, condenser shall be capable of taking at least 60% T.G. load under TMCR conditions.
- f) The capacity of each vacuum pump in free dry air under standard conditions at a condenser pressure of 25.4 mm Hg (abs) and sub cooled to 4.17 deg. C below the temperature corresponding to absolute suction pressure shall not be less than 30 SCFM. Correction curves for establishing the capacity at site conditions shall also be furnished.
- g) The air and vapour mixture from air cooling zone of condenser shall be 4.17⁰C below the saturation temperature corresponding to 25.4 mm Hg (abs) suction pressure. Correction curves for establishing the same at site conditions shall also be furnished.
- h) Life of sponge rubber balls and number of balls lost during 1000 hours of plant operation shall be as indicated by bidder in the offer and accepted by the purchaser.



xxiii) **Feed water heaters and deaerator**

The following parameters shall be demonstrated:

- a) TTDs and DCA's of feed water heaters as per guaranteed heat balance diagram.
- b) Dissolved O₂ content in feed water at deaerator outlet without chemical dosing at all loads, not to exceed 0.005 cc/litre determined as per ASTM-D-888 – Reference method-A or Indigo Carmine method.
- c) Difference between saturation temperature of steam entering the deaerator and temperature of feed water leaving the deaerator.
- d) Continuous and efficient operation and performance of feed heating plant without undue noise and vibrations at all loads and duty conditions.

xxiv) **Condensate extraction pumps**

The Contractor shall demonstrate the following:

- a) Each CEP set shall be capable of delivering the flow and total dynamic head corresponding to best efficiency point.
- b) Each CEP set shall be capable of delivering flow and total dynamic head corresponding to runout point as specified.
- c) The vibration, noise level and parallel operation of any two of the three pumps as per specification requirements.

xxv) **Boiler feed pumps**

The Contractor shall demonstrate the following:

- a) Each boiler feed pump set shall be capable to deliver flow and total dynamic head corresponding to best efficiency point as specified elsewhere.
- b) Each boiler feed pump set shall be capable to deliver flow and total dynamic head corresponding to runout point as specified elsewhere.
- c) The power consumption of motor driven BFP at best efficiency point.
- d) The vibration, noise level and parallel operation of any two of the three pumps as per specification requirements.

xxvi) **Automatic on-line turbine testing (ATT) system**

On-load testing of turbine protective equipments without disturbing normal operation and keeping all protective functions operative during the test.

xxvii) **Condensate polishing unit**

Operation run length between two successive regenerations as per requirement of the specification.



xxviii) **EOT crane**

After assembly and erection of crane at site, the crane shall be subjected to following tests:

- a) Deflection test
- b) Overload test
- c) Brake test
- d) Other tests as per IS: 3177-1999.

xxix) **Lifts/ elevators**

- a) The lifts/ elevators shall pass the following tests as per IS: 14665 Part 3 when carried out at site and before it is put into normal service:

- Test to determine the insulation resistance between power and control lines.
- Test to determine earthing of all conduit switch castings and similar metal work.
- Test to determine that motor, brake, control equipment and door locking devices and limit switches function correctly.
- Tests to determine vibration levels of the elevators.
- Tests to determine that the lift car raises and lowers rated load.
- Test to determine that the lift car achieves the contract speed.
- Test to determine that the safety gear stops the lift car with rated load and over speed tests.

- b) Inspection for safety

The elevators shall be offered for inspection from safety point of view by the inspector of lifts or any other officer appointed by State/Union Govt. to maintain Lift Act/Rules or any other Act/ Rules connected with safety of lifts. The inspection shall be carried out as per IS: 14665 (Part 5): 1999. The inspection shall be done from the following five places:

- Elevator pit
- Inside of the elevator car.
- Top of the elevator car.
- Machine room.
- Each and every landing of the elevator.

The responsibility of getting the above inspection shall be of the contractor.



c) **Acceptance**

Should the field tests under (a) and (b) above show that equipment fails to meet the guarantee and specified requirement, the supplier shall carry out the necessary changes or corrections or replacements and shall assume full responsibility and take all necessary steps to fully meet the required performance and prescribed guarantees.

xxx) **Air conditioning system**

The following shall be demonstrated at site:

- a) AC plant capacity of each area and guaranteed room conditions during summer and monsoon for all air conditioned areas alongwith power consumption of air conditioning units.
- b) Parallel operation, vibration & noise level of rotating equipments.

xxxii) **Ventilation system**

The following shall be demonstrated at site:

- a) Inside dry bulb temperature for evaporative cooled areas.
- b) Temperature rise in areas for which ventilation system is designed on the basis of temperature rise over ambient air temperature.
- c) Parallel operation, vibration & noise level of rotating equipments.

xxxiii) **Transformers**

The Contractor shall demonstrate the following for all the transformers:

<u>Test</u>	<u>Maximum limit over guaranteed value</u>
No load loss	20%
Load loss	20%
Oil or winding temperature rise	5°C

The purchaser may reject the transformer if the above limits are exceeded.

xxxiiii) **Control and instrumentation system**

The Contractor shall demonstrate the following:

- a) Performance requirements for Closed loop control system as specified in Section- 6 of this Specification.
- b) Parametric tests for DDC system as specified in Section- 6 of this Specification.



1.6.5 Performance Guarantee/ Acceptance Test

1.6.5.1 General requirements

- i) It is the responsibility of the Contractor to perform the performance guarantee/ acceptance test as specified in this sub-section. The performance guarantee tests will be performed using only the normal number of purchaser supplied operating staff. Contractor, vendor or other subcontractor personnel shall only be used for instructional purposes or data collection.
- ii) The Contractor shall make the plant ready for the performance guarantee tests.
- iii) All instruments required for performance testing shall be of the type and accuracy required by the relevant codes and prior to the test, the contractor shall get these instruments calibrated in an independent test Institute approved by the purchaser. All test instrumentation required for performance tests shall be supplied by the contractor and shall be retained by him upon satisfactory completion of all such tests at site. All costs associated with the supply, calibration, installation and removal of the test instrumentation shall be included in the bid price. All calibration procedures and standards shall be subjected to the approval of the purchaser. The protecting tubes, pressure connection and other test connections required for conducting guarantee test shall conform to the relevant codes.
- iv) Tools and tackles, thermowells (both screwed and welded) instruments/devices including flow devices, matching flanges, impulse piping and valves etc. and any special equipment, required for the successful completion of the tests shall be provided by the contractor free of cost.
- v) The contractor shall submit for purchaser's approval the detailed performance test procedure containing the following:
 - a) Object of the test
 - b) Various guaranteed parameters and tests as per contract
 - c) Method of conductance of test and test code
 - d) Duration of test, frequency of readings and number of test runs.
 - e) Method of calculation
 - f) Correction curves
 - g) Instrument list consisting of range, accuracy, least count and location of instruments.
 - h) Scheme showing measurement points
 - i) Sample calculation
 - j) Acceptance criteria
 - k) Any other information required for conducting the test.



- vi) The performance guarantee/ acceptance test shall be carried out as per the agreed procedure. The PG test procedure including demonstration tests shall be submitted by the bidder during detailed engineering for approval of the purchaser. After the conductance of performance guarantee test, the contractor shall submit the test evaluation report of performance test results to purchaser promptly but not later than one month from the date of conductance of performance guarantee test. However, preliminary test reports shall be submitted to the purchaser after completing each test run.
- vii) In the event of a test interruption resulting from an event of force- majeure or purchaser caused delay, contractor shall be entitled to relief as provided in the contract, provided that (except for certain interruptions of a Availability Test as specified below), the interrupted Performance Test must be started again and test data that were collected during the interrupted test must be ignored.

In the event of test interruptions as a result of force- majeure or purchaser caused delay during an availability test, where.

- a) The total cumulative interrupted time during the test is more than twenty-four (24) hours.
- b) The total number of interruptions during the test is more than four (4), the test shall not be deemed a successful performance guarantee test.

Except as provided above, the interrupted test resulting from force- majeure or purchaser caused delay shall be extended by an amount of time equal to the length of the interruptions, including time to return to steady-state operation; the test data for the period of interruptions shall be excluded from analysis; and the test data that were collected both before and after the interruptions shall be included in the analysis.

- viii) Any loss in generation in terms of power (kW) or energy (kWh) during availability test due to grid restrictions shall be treated as deemed generation. However, the total cumulative deemed generation shall not exceed 5% of the total generation during the test period failing which the test shall be extended to limit the deemed generation to 5% of the total generation.

1.6.5.2 Steam generator efficiency tests

- i) Test code : As per BS EN 12952- 15, 2003 (by loss method)
(except for specific requirements brought out herein)
- ii) Test loads : 100% TMCR and 80% TMCR
- iii) Test conditions : Boiler operating at rated steam parameter, excess air, coal fineness and firing design coal.
- iv) Ambient conditions : 27^oC dry bulb temperature and 60% relative humidity. The reference air temperature for the efficiency guarantee/ testing shall be taken as the temperature of air (i.e.27^oC) entering PA and FD fans.



- v) No. of readings : Two sets of consistent readings for each of test loads. Average of the test efficiencies based on above two readings for each load shall be considered for guaranteed efficiency.

- vi) Measurement and computation of heat losses will include but not be limited to the following:

Sl. No. Losses to be measured

- a) Dry gas loss
- b) Loss due to hydrogen in fuel
- c) Loss due to moisture in fuel
- d) Loss due to moisture in air
- e) Loss due to unburnt carbon

Ash samples shall be collected from the furnace bottom hoppers, airheater, economiser and ESP hoppers, duct hopper (if applicable). The ash collection distribution for computation of losses shall be 20%, 3%, 5% in the furnace bottom hopper, air heater, economiser/ duct hoppers (if applicable) and balance in ESP hoppers.

- f) Radiation loss
- g) Loss due to carbon mono- oxide (CO) in flue gas
- h) Loss due to sensible heat in ash

To be computed based on the ash collection distribution indicated at (e) above and ash temperature of furnace bottom ash as 1040⁰C. The temperature of economizer/ dust hopper ash, air heater hopper ash and ESP ash shall be considered same as that of flue gas in these areas.

- i) Loss due to radiation from furnace bottom

To be worked out based on bottom hopper opening and heat flux in these area.

- j) Loss due to mill rejects

The total mill rejects throughout the test (minimum four hours) from all mills shall be considered as one gross which will be weighed to workout the reject rate and then reduce by halving and quartering to the required sample size for calorific value analysis to be used for working out loss due to mill rejects.

- vii) The guaranteed steam generator efficiency shall be without any heat credit.



- viii) The steam generator efficiency shall be guaranteed based on ambient air temperature of 27°C and relative humidity of 60%.
- ix) Correction to tested efficiency shall be applicable for variation in following parameter only:
 - a) Ambient air temperature
 - b) Relative humidity of ambient air
 - c) Hydrogen in coal.
 - d) Moisture in coal.
 - e) GCV of coal.
 - f) Percentage of ash in coal.
 - g) Heat output of steam generator.
- x) The duration of the efficiency test shall be four hours. No soot blowing shall be allowed during the test period or during stabilization period of four hours prior to commencement of the test.
- xi) The bidder shall furnish the correction curves, for purchaser's approval covering the expected ranges of variations for all these parameters for the range of coal specified.
- xii) For all other aspects, not spelt out above, or in the specifications, where the relevant code stipulates the agreement between the parties concerned before commencement of the test, the bidder shall get these approved by the purchaser. However no correction to SG efficiency on account of variation in turbine cycle parameters, or vice versa shall be allowed.
- xiii) The number, location type and accuracy of the test grade thermocouples and pressure gauges shall be to purchaser's approval.
- xiv) The steam generator efficiency testing shall be carried out with any combination of mills in operation to purchaser's choice, with fineness of pulverized coal not exceeding 70% through 200 mesh.
- xv) Steam generator efficiency shall be with guaranteed or actual air heater leakages, whichever is higher.

1.6.5.3 Method of computing test efficiency of ESP

- i) The performance test on electrostatic precipitator will commence after a minimum period of three thousand (3000) hours of continuous operation after completion of initial operation. During the interval between the commencement of initial operation and the commencement of performance test only routine



maintenance shall be carried out. No physical or chemical cleaning of ESP shall be permitted during this period or immediately before the conductance of the performance tests.

- ii) The test efficiency shall be based on the overall performance of the electrostatic precipitator over a mutually agreed period of operation under the conditions given in this specification and allowing the normal operation of the unit including rapping and normal soot blowing and / or when fuel oil is being fired in the ignitors and / or warm up guns.

The overall test efficiency and test temperature/inlet dust burden for one set of ESPs serving one steam generator shall be worked out as follows :

- a) V_m (guarantee point test flow) shall be the total of inlet gas flows to the four gas streams at the time of test
- b) Test inlet dust burden (D_i) shall be weighted mean of the inlet dust burdens for the individual streams i.e.:

$$D_i = \frac{(V_{m1} \times D_{i1}) + (V_{m2} \times D_{i2}) + (V_{m3} \times D_{i3}) + (V_{m4} \times D_{i4})}{(V_{m1} + V_{m2} + V_{m3} + V_{m4})}$$

Similarly the test outlet dust burden (D_o) will be calculated based on outlet gas flow.

- c) The weighted test inlet gas temperature (T_i) shall also be worked out in a similar manner i.e.

$$T_i = \frac{(T_{i1} \times V_{m1}) + (T_{i2} \times V_{m2}) + (T_{i3} \times V_{m3}) + (T_{i4} \times V_{m4})}{(V_{m1} + V_{m2} + V_{m3} + V_{m4})}$$

- d) The measured test efficiency shall be:

$$E_m = \frac{(D_i - D_o) \times 100}{D_i} (\%)$$

- e) The corrections for the flue gas flow and ESP inlet flue gas temp. in excess of the values for these parameters under guarantee point conditions, shall be allowed only in case and to the extent such variations are caused solely due to changes in specified coal properties and ambient conditions. Further, the corrections for the flue gas flow and temperature lower than the guarantee point values shall be applied based on actually measured test values.

Subject to the above, the corrections for the variations in gas flow, gas temperature and inlet dust burden shall be based on the computed test values and the procedure indicated in the next para.

- iii) At the time of performance testing if the inlet flue gas conditions are not consistent with the specified conditions, due to variation in coal characteristics from the design coal and boiler operating conditions, the precipitator performance conforming to this specification, shall be determined using performance curves and correction factors accepted at the time of award of contract. However no correction shall be admissible for variation in ESP inlet parameters other than the extent to which the variations are due to ambient /coal characteristics. However, the test efficiency shall be corrected to guarantee point conditions in the following manner:

a) $E_g = 1 - e^Y$

Where $Y = (V_m/V_g)^{0.5} \ln (1-E_m)$

E_g = Measured test efficiency corrected to the specified guarantee point flow only to the extent variation is due to ambient air condition/coal characteristics.

V_g = Specified guarantee point gas flow (m^3/s)

V_m = Measured gas flow (m^3/s)

E_m = Measured test efficiency

\ln = Logarithm, natural base.

b) $E_c = 1 - e^Z$

Where E_c = Corrected test efficiency to guarantee point conditions

$Z = C \cdot \ln (1 - E_g)$ and

and $C = C_a \cdot C_b \cdot C_c$ etc.

C_a, C_b, C_c etc. = Correction factor for flue gas at temperature, inlet dust loading, sulphur, sodium contents of coal ash based on correction curves furnished by the bidder subject to owner's approval.

The correction curves should be realistic for expected range of operation and variation in characteristics specified.

The test efficiency shall be the average of at least three corrected test efficiencies.



- iv) The performance/acceptance tests shall be carried out in accordance with method-17 of EPA (Environmental Protection Agency of USA) code ASME PTC. The details of the test shall, however be mutually agreed upon between the owner and the contractor.

1.6.5.4 Turbine generator performance/acceptance test

- i) Performance test for the turbine generator set will be conducted in accordance with the latest edition of ASME PTC-6. Such test shall be binding on the parties to the contract to determine compliance with the guaranteed heat balance conditions at 100% and 80% TMCR outputs corresponding to the conditions stipulated under clause 1.6.2.1 of this sub-section. Power consumed by the auxiliaries mentioned under clause 1.6.2.4 of this sub-section which is to be deducted from electrical power generated shall be measured during the performance/acceptance test. Wherever the measurement is not possible, design values of power consumption by an auxiliary shall be considered.
- ii) The essential mandatory requirements for instruments, methods and precautions to be employed shall be in accordance with the requirements specified in the respective codes. All the necessary instruments (in duplicate) required for the tests shall be furnished by the contractor so as to meet the accuracies specified in the codes. Any advanced class instrument system such as those using electronic devices or mass flow technique shall be arranged by the contractor, if required. For determination of primary flow to the turbine, a calibrated low Beta-ratio throat-tap nozzle assembly including required machined straight lengths meeting the requirement of ASME PTC-6 shall be provided. The test procedures, calibration standards, calibration procedures etc. shall be subject to purchaser's approval. All the instruments including the flow nozzle shall be calibrated by the contractor before and after the test, in a reputed international institute as approved by the purchaser. However, post test calibration of flow nozzle shall not be mandatory. These calibrations shall be performed in the presence of the purchaser. All calibrations shall be made available prior to the test and calibration certificates in original submitted to purchaser at least 15 days before conductance of the test for purchaser's approval. The instruments shall be sealed after calibration by calibrating lab. The percentage calibration error/deviation should not be more than accuracy class of the instrument.
- iii) Corrections to the test results for steam turbine shall be applied as per the correction curves furnished along with the bid. The corrections as listed in Section- 3 shall be applied. When the system is properly isolated for a performance test, the unaccounted for leakages should not be more than 0.1% of the design throttle flow at that load. To achieve the above value of unaccounted for leakages, the bidder shall prepare the unit during pretest available shutdown. However, during the test if it is found that the unaccounted leakage is more than 0.1% of design throttle flow at the load, then heat rate will be increased by an amount equal to half the difference between actual unaccounted for leakage expressed as percentage of design throttle flow at that load and 0.1% (allowed by the code).



- iv) The performance guarantee test will be carried out after successful completion of trial operation. Ageing allowance shall be given during evaluation of PG test results and hence guaranteed heat rate shall be increased by the amount calculated as per the formula given in clause No. 3.07, sub-section-3 of ASME-PTC-6 report 1985 (reaffirmed latest). Period of ageing shall be considered from the date of successful completion of trial operation to the date of conductance of PG test. In calculating the above factor any period(s) during which the turbine has not been in operation at a stretch for more than a week shall not be considered.
- v) The tests shall be arranged in a manner that the purchaser's operation is not disrupted. Duplicate test runs shall be performed at 100% TMCR and 80% TMCR unit loads. The results of corrected heat rate shall agree within 0.25%. If they differ by more than 0.25%, third test shall be run at the same point. The corrected result of any one of the three test runs, which deviates from the corrected averaged result of all the runs by more than 0.25% shall be eliminated; otherwise the results of all the three tests runs shall be accepted.
- vi) During performance/acceptance test, following tests shall be carried out for TG set with test grade instruments as per ASME code:
- a) Turbine cycle heat rate in kcal/kWh under rated steam conditions at design condenser pressure with zero make up at 100% TMCR unit load.
 - b) Turbine cycle heat rate in kcal/kWh under rated steam conditions at design condenser pressure with zero make up at 80% TMCR unit load.
 - c) Continuous TG output of 100% TMCR unit load under rated steam conditions at design condenser pressure with 3% make up.
 - d) Auxiliary power consumption at 100% TMCR and 80% TMCR unit loads under rated steam conditions and at design condenser pressure with 0% make up.
 - e) Continuous TG output of 100% TMCR unit load under rated steam conditions at 89 mm Hg (abs) ⁶ pressure with 3% make up.
 - f) Continuous output at generator terminals corresponding to VWO condition under rated conditions at design condenser pressure and 3% make up.
 - g) Maximum continuous output at generator terminals corresponding to one string of HP heater out of operation under rated steam conditions at design condenser pressure and 3% make up.
 - h) Maximum continuous output at generator terminals corresponding to both strings of HP heaters out of operation, under rated steam conditions, at design condenser pressure and 3% make up.

⁶ 70 mm of Hg (abs) in case of sea water based once- through CW system



- vii) Performance test for the condensers will be conducted in accordance with the latest editions of ASME PTC-12.2 with the exception at (a) mentioned below:
 - a) Condenser pressure will be measured at 300 mm above the top row of tubes under VWO conditions, 3% make-up and design C.W. flow and design temperature. The condenser pressure shall be measured with a vacuum grid utilizing ASME basket tips. The grid is fitted at 300 mm above top row of condenser tubes.
 - b) Combined pressure drop in condenser tube, water box and inlet and outlet piping will be measured in between intake and discharge point of the CW system at bidder's terminal points with cleanliness factor of 0.9 and COLTCS in service.

- viii) Performance guarantee/ acceptance tests on the equipments/ systems not covered in this Sub-Section shall be carried out as per the procedure/test codes/specified in respective detailed specifications/sub-sections.



1.7 SPARE PARTS

The bidder shall include in his scope of supply all the necessary mandatory spares, start up and commissioning spares and recommended spares and indicate these in the relevant schedules. The general requirements pertaining to the supply of these spares is given below:

1.7.1 Mandatory Spares

- i) The list of mandatory spares considered essential by the purchaser is enclosed in Section 9 of this specification. The bidder shall indicate the prices for each and every item (except for items not applicable to the bidders design) in the 'Schedule of mandatory spares' whether or not he considers it necessary for the purchaser to have such spares. If the bidder fails to comply with the above or fails to quote the price of any spare item, the cost of such spares shall be deemed to be included in the contract price. The bidder shall furnish the population per unit of each item in the relevant Schedules. Whenever the quantity is mentioned in "sets" the bidder has to give the item details and prices of each item.
- ii) Whenever the quantity is indicated as a percentage, it shall mean percentage of total population of that item in the station (project) unless specified otherwise, and the fraction will be rounded off to the next higher whole number. Wherever the requirement has been specified a 'set' it will include the total requirement of the item for a unit, module or the station or as specified. Where it is not specified a 'set' would mean the requirement for the single equipment/system as the case may be. Also the 'set' would include all components required to replace the item; for example, a set of bearings shall include all hardware normally required while replacing the bearings.
- iii) The purchaser reserves the right to buy any or all the mandatory spare parts.
- iv) The prices of mandatory spares indicated by the bidder in the Bid Proposal shall be used for bid evaluation purposes.
- v) All mandatory spares shall be delivered at site at least two months before scheduled date of initial operation of the first unit. However, spares shall not be dispatched before dispatch of corresponding main equipments.
- vi) Wherever quantity is specified both as a percentage and a value, the bidder has to supply the higher quantity until and unless specified otherwise.

1.7.2 Recommended Spares

- i) In addition to the spare parts mentioned above, the Contractor shall also provide a list of recommended spares for five (5) years of normal operation of the plant and indicate the list and total prices in relevant schedule. The list shall take into consideration the mandatory spares specified and should be independent of the list of the mandatory spares. The purchaser reserves the right to buy any or all of the recommended spares. The recommended spares shall be delivered at project site at least two months before the scheduled date of initial operation of first unit. However, the spares shall not be dispatched before the dispatch of the main equipment.



- ii) Prices of recommended spares will not be used for evaluation of the bids. The price of these spares will remain valid upto execution of the contract. However, the Contractor shall be liable to provide necessary justification for the quoted prices for these spares as desired by the purchaser.

1.7.3 Start up and Commissioning Spares

Start up and commissioning spares are those spares which may be required during the start-up and commissioning of the equipment/system till the commercial operation of the Plant. The Contractor shall provide all such start up and commissioning spares and keep an adequate stock of the same to be brought by him to the site for the plant erection and commissioning. These must be available at site before the equipments are energized. The unused spares, if any, should be removed from there only after commercial operation of the plant. All start up spares which remain unused at the time shall remain the property of the Contractor.

1.7.4 General

- i) The Contractor shall indicate the service expectancy period for the spares parts (both mandatory and recommended) under normal operating conditions before replacement is necessary.
- ii) All spares supplied under this contract shall be strictly inter-changeable with the parts for which they are intended for replacements. The spares shall be treated and packed for long storage under the climatic conditions prevailing at the site e.g. small items shall be packed in sealed transparent plastic with desiccator packs as necessary.
- iii) All the spares (both recommended and mandatory) shall be manufactured alongwith the main equipment components as a continuous operation as per same specification and quality plan.
- iv) The contractor will provide purchaser with cross-sectional drawings, catalogues, assembly drawings and other relevant documents so as to enable the purchaser to identify and finalise order for recommended spares.
- v) Each spare part shall be clearly marked or labeled on the outside of the packing with its description. When more than one spare part is packed in a single case, a general description of the content shall be shown on the outside of such case and a detailed list enclosed. All cases, containers and other packages must be suitably marked and numbered for the purposes of identification.
- vi) All cases, containers or other packages are to be opened for such examination as may be considered necessary by the purchaser.
- vii) The Contractor will provide the purchaser with all the addresses and particulars of his sub-suppliers while placing the order on vendors for items/ components/ equipments covered under Contract and will further ensure with his vendors that the purchaser, if so desires, will have the right to place order for spares directly on them on mutually agreed terms based on offers of such vendors.
- viii) The Contractor shall warrant that all spares supplied will be new and in accordance with the Contract documents and will be free from defects in design, material and workmanship.



- ix) In addition to the recommended spares listed by the Contractor, if the purchaser further identifies certain particular items of spares, the Contractor shall submit the prices and delivery quotation for such spares within 30 days of receipt of such request for consideration by the purchaser and placement of order for additional spares if the purchaser so desires.
- x) The Contractor shall guarantee the long term availability of spares to the purchaser for the full life of the equipment covered in the Contract. The Contractor shall guarantee that before going out of production of spare parts of the equipment covered under the Contract, he shall give the purchaser at least 2 years advance notice so that the latter may order his bulk requirement of spares, if he so desires. The same provision will also be applicable to Sub-contractors. Further, in case of discontinuance of manufacture of any spares by the Contractor and/or his sub-contractors, Contractor will provide the purchaser, two years in advance, with full manufacturing drawings, material specifications and technical information including information on alternative equipment makes required by the purchaser for the purpose of manufacture/procurement of such items.
- xi) The prices of all future requirements of spares beyond 5 years shall be derived from the corresponding FOB/Ex-works price at which the order for such spares have been placed by the purchaser as a part of the mandatory spares or recommended spares. FOB/Ex-works order price of future spares shall be computed in accordance with the price escalation formula to be furnished by Contractor indicating base price reference variation indices for material, labour etc. Based on the formula and considering escalation indices prevailing at the time of order of spares, order price shall be worked out. The base indices will be counted from the scheduled date of successful completion of trial operation of the last plant/equipment under the project. The above option for procuring future recommended spares by the purchaser shall remain valid for the period of fifteen (15) years from the date of successful completion of trial operation of the last plant/equipment. In case the spare parts from the same sub-vendor are not available due to obsolescence or any other reason, the Contractor shall supply the spares for a period of fifteen (15) years from an alternative source.



1.8 TESTING, INSPECTION AND QUALITY ASSURANCE PLAN

- i) All materials, components and equipments covered under this specification shall be tested at all stages of procurement, manufacturing, erection, commissioning as per a comprehensive quality assurance programme. The requirements of quality plans to be followed by the bidder in respect of various equipment are detailed in Section - 8 of this specification. The bidder shall draw his own quality plans in line with these requirements and his standard practices and implement such programme after approval by the purchaser.
- ii) Manufacturing quality plan will detail out, for all the components and equipments, various tests/inspection to be carried out as per the requirements of this specification and standards mentioned therein and quality practices and procedures followed by contractor's quality control organization, the relevant reference document and standards, acceptance norms and inspection documents raised etc. during all stages of material procurement, manufacture, assembly and final testing/performance testing.
- iii) Field quality plans will detail out for all the equipments, the quality practices and procedure etc. to be followed by the Contractor's site quality control organization during various stages of site activities including receipt of materials/equipments at site, preservation and storage, pre-assembly, erection, pre-commissioning and commissioning.
- iv) The bidder, along with quality plan, shall also furnish copies of the reference documents/plant standards/acceptance norms/test and inspection procedure etc. referred by him in quality plans. These quality plans and reference documents/standards etc. will be subject to purchaser's approval and will form a part of the contract. In these approved quality plans, purchaser shall identify customer hold points (CHP), indicating tests/checks which shall be carried out in presence of the purchaser's engineer or authorized representative and beyond which work will not proceed without consent of purchaser's Engineer/authorized representative in writing.
- v) No materials/equipment shall be dispatched from the manufacturer's works before the same is either accepted subsequent to pre-dispatch final inspection including verification of records of all previous tests/inspections by purchaser's Engineer /authorized representatives, or such pre-dispatch final inspection is waived by the purchaser and dispatch is authorized after review of test reports.
- vi) All materials used or supplied shall be accompanied by valid and approved material certificates and test and inspection reports duly approved by the purchaser. These certificates and reports shall indicate the acceptable identification number of the material they proposed to certify. The material certified shall also have the identification details stamped on it.



- vii) All material used for equipment construction including castings and forgings etc. shall be of tested quality as per relevant codes/standards. Details of results of the test conducted to determine the mechanical properties, chemical analysis and details of heat treatment procedures recommended and actually followed shall be recorded on certificates and time temperature chart. Tests shall be carried out as per applicable material standards and/or agreed details.
- viii) All welding shall be carried out as per welding procedure drawn and qualified in accordance with requirements of ASME Section IX. Welding procedures shall be submitted to the purchaser for approval prior to carrying out qualification test in the presence of purchaser's representative.
- ix) All welders/welding operators employed on any part of the contract either in the Supplier's works or at site or elsewhere shall be qualified as per ASME Section-IX.
- x) Test results of qualification tests and specimen testing shall be furnished to the purchaser for approval. However, wherever required by the purchaser, tests shall be conducted in presence of purchaser's Engineer/ authorized representative.
- xi) All the heat treatment results shall be recorded on time temperature charts and verified with recommended regimes.
- xii) All the sub-vendors proposed by the bidder for procurement of major bought out items including castings, forgings, pumps, heat exchangers, semi finished and finished components/equipment-(list of which shall be drawn up by the bidder along with his offer and finalized with the purchaser) shall be subject to purchaser's approval.
- xiii) All the purchase specifications for the major bought out items, list of which shall be drawn up by the Contractor and finalized with the purchaser, shall be furnished to the purchaser for comments and subsequent approval before orders are placed as per those specifications.
- xiv) Purchaser reserves the right to carry out quality audit and quality surveillance of the systems and procedures of the Contractor and their sub-vendors for quality management and control activities. The Contractor shall provide all necessary assistance to enable the purchaser carry out such audit and surveillance.
- xv) The Contractor shall undertake an inspection and testing programme during manufacture in his works and that of his sub-contractor's to ensure the mechanical accuracy of components, compliance with drawings, conformance to functional and performance requirements, identification and acceptability of all materials, parts and equipment. In addition to tests as per the approved quality plan, the Contractor shall also carry out all tests/inspection required to establish that the items/equipments conform to requirements of this specification and the relevant codes/standards specified in this specification.



- xvi) The purchaser/ Engineer and/or his duly authorised representative shall have at all reasonable times access to the contractor's premises or works and shall have the power at all reasonable times to inspect and examine the materials and workmanship of the works during its manufacture or erection and part of the work being manufactured or assembled on other's premises or works. The contractor shall obtain for the Engineer and his duly authorised representative the permission to inspect as if the works were manufactured or assembled on the contractor's premises or works.
- xvii) The contractor shall give the Engineer/ Inspector fifteen (15) days written notice of any material being ready for testing. Such tests shall be to the contractor's account except for the expenses of the Inspector. The Engineer/Inspector unless the inspection of the tests is virtually waived, shall attend such tests within fifteen (15) days of the date on which the equipment is notified as being ready for test/inspection, failing which, the contractor may proceed with the test which shall be deemed to have been made in the Inspector's presence and he shall forthwith forward to the Inspector duly certified copies of tests in triplicate.
- xviii) The Engineer or Inspector shall within fifteen (15) days from the date of inspection as defined herein give notice in writing to the contractor of any objection to any drawings or any equipment and workmanship which in his opinion is not in accordance with the contract. The contractor shall give due consideration to such objections and shall either make the modifications that may be necessary to meet the said objections or shall confirm in writing to the Engineer/Inspector, giving reasons therein that no modifications are necessary to comply with the contract.
- xix) When the factory tests have been completed at the contractor's or sub-contractor's works, the Engineer/Inspector shall issue a certificate to this effect within fifteen (15) days after completion of test. If the tests are not witnessed by the Engineer/Inspector, the certificate shall be issued within fifteen (15) days of the receipt of the contractor's test certificate by the Engineer/Inspector. Failure of the Engineer/Inspector to issue such a certificate shall not prevent the contractor from proceeding with the works. The completion of these tests or the issue of the certificate shall not bind the owner to accept the equipment, should on further tests after erection, the equipment is found not to comply with the contract.
- xx) In all cases where the contract provides for tests whether at the premises or works of the contractor or of any sub-contractor, the contractor, except where otherwise specified, shall provide free of charge such items as labour, materials, electricity, fuel, water, stores, apparatus and instruments as may be reasonably demanded by the Engineer/Inspector or his authorised representative, to accomplish testing.



- xxi) Quality audit/surveillance/approval of the results of the tests and inspection will not, however, prejudice the right of the purchaser to reject the equipment if it does not comply with the specification when erected or does not give complete satisfaction in service and the above shall in no way limit the liabilities and responsibilities of the Contractor in ensuring complete conformance of the materials/equipment supplied to relevant specification, standards, data sheets, drawings etc.

- xxii) The cost of all the tests shall be borne by the Contractors.



STANDARD TECHNICAL SPECIFICATION FOR MAIN PLANT PACKAGE

SECTION- 2

(STEAM GENERATOR AND AUXILIARIES)

2.1 DESIGN AND SIZING CRITERIA

2.1.1 Type of Steam Generator

The steam generators shall be drum type with assisted circulation, water tube, direct pulverised coal fired, balanced draft furnace, single reheat, radiant, dry bottom, suitable for semi-outdoor installation and top supported. The gas path arrangement of steam generators shall be two pass type. The design and sizing of various plants, systems, equipment offered for the steam generators and auxiliaries shall comply with the general requirements indicated in the specification.

2.1.2 Contractor's Responsibilities

The criteria specified are the minimum design and sizing requirements of the purchaser and all components, equipments and systems are to be designed to cater to these requirements. Contractor's utilisation of various values and criteria indicated by the purchaser shall in no way relieve the Contractor of his responsibilities to meet all guarantee requirements or of providing completely safe and reliable operating equipments/ systems.

2.1.3 Unit Operation Range

The specified requirements shall be complied for the most stringent conditions resulting either from the range of coals specified or from the range of operating conditions specified (like 100% BMCR or HP heaters out or variable/ constant pressure operation etc.), or from both occurring simultaneously, unless otherwise specifically mentioned by the purchaser.

2.1.4 Codes and Standards

- i) All equipment, systems and work covered under this specification shall comply with all latest statutes, regulations and safety codes, as applicable in the location where the equipment will be installed.
- ii) The design of steam generator shall meet or exceed all the requirements of latest editions of Indian Boiler Regulations (IBR).
- iii) Any other standards acceptable to IBR can also be considered, provided the requirements of those standards are equivalent or exceed the IBR requirements.
- iv) Wherever the specification stipulates requirements in addition to those specified in IBR, the same shall also be complied by the Contractor.



- v) In cases where IBR does not govern, other international standards established to be equivalent or superior to the codes and standards specified, are also acceptable. However, in the event of any conflict between the requirements of the equivalent codes and standards, and the requirements of the Indian standards/ regulations, the latter shall govern, unless, specified otherwise in the specification.
- vi) It shall be responsibility of the Contractor to obtain the necessary approvals of Inspection Authority/ Chief Inspector of Boilers on behalf of the purchaser, as may be required for designing and design calculations, manufacturing and erection procedure, testing etc. as called for under the IBR. All such documentation submitted to statutory authorities shall also be submitted to the purchaser for his review. It shall also be the responsibility of the Contractor to furnish the requisite documentation as required by the purchaser for getting the boiler registered under IBR.

2.1.5 Steam Generator Rating

The Steam Generator shall be designed to cater to duty requirement/ rating specified below:

<u>Description</u>	<u>Rated parameters</u>
i) Steam flow at superheater outlet at boiler maximum continuous rating (BMCR)	: 1.02 times the steam flow at turbine VWO condition plus continuous auxiliary steam requirement of unit at TMCR rounded to next integer divisible by 5.
ii) Steam temperature :	
a) At superheater (SH) outlet	: To correspond to HP turbine inlet parameters of 537°C (indicative value: 540°C).
b) At re-heater (RH) outlet	: To correspond to IP turbine inlet temperature of 565°C (indicative value: 568°C).
iii) Feed water temperature at economizer inlet	: To be selected by the bidder based on his optimisation of the turbine cycle. The steam generator shall also be suitable for accepting feed water at lower temperatures corresponding to HP heaters out of service condition without exceeding any of its design limits including design metal temperatures.
iv) Steam pressure at superheater outlet	: To correspond to turbine throttle steam pressure of 170 kg/cm^2 (abs) [indicative value: 179 kg/cm^2 (abs)].
v) Steam generator control range	: 50% TMCR to 100% BMCR. However, the bidder to specify the feasible mill combinations below 60% TMCR.



Note:

- a) Pressure drop in reheater should not exceed 2.5 kg/cm^2 under all operating conditions.
- b) The steam temperatures at superheater and reheater outlet(s) shall be guaranteed to be maintained at $\pm 5^\circ \text{C}$ of the rated value at all loads within control range, under all operating conditions including HP heaters out of service condition.

2.1.6 Fuels

A) Coal

- i) The plant systems shall be designed considering project specific data¹ on coal quality and ash analysis. However, the typical coal quality parameters on as received basis are indicated below: -

Sl. No.	Particulars	Units	Performance coal	Worst coal
A.	Proximate analysis			
1.	Moisture	%	10	15
2.	Ash	%	35	45
3.	Fixed carbon	%	31	20
4.	Volatile matter	%	24	20
	Total	%	100	100
B.	Gross calorific value	kcal/kg	4100	3200
C.	Grindability index	HGI	50	50
D.	Ultimate analysis			
1.	Carbon	%	43.02	32.88
2.	Hydrogen	%	2.82	2.13
3.	Sulphur	%	0.45	0.28
4.	Nitrogen	%	0.81	0.59
5.	Oxygen (by difference)	%	7.90	4.12
6.	Moisture	%	10.0	15.0
7.	Ash	%	35	45
	Total	%	100	100

¹ Coal and ash analysis data to be furnished by the purchaser.



ii) Typical Ash analysis

Characteristics	Range/ value
SiO ₂	54 to 60 %
Al ₂ O ₃	27 to 31 %
Fe ₂ O ₃	3 to 5%
TiO ₂	0.3 to 0.5%
CaO	1 to 3%
MgO	0.5 to 1.5%
Chloride as Cl	0.03 to 0.06%
Sulphate as SO ₄	0.1 to 0.2%
Alkalies as NaOH	< 0.01mg/kg
Chromium as Cr	25 to 28 mg/kg
Mercury as Hg	< 0.002 mg/kg
Lead as Pb	<0.1 mg/kg
Cadmium as Cd	< 0.01 mg/kg
Nickel as Ni	71 to 95 mg/kg
Zink as Zn	84 to 86 mg/kg
Copper as Cu	56 to 60 mg/kg

- iii) Correction curves shall be furnished by the bidder for the variation of coal quality parameters for making adjustment on calculated efficiency during performance guarantee test of the unit(s).
- iv) The steam generator and its auxiliaries shall be capable of giving the guaranteed maximum continuous output under the most adverse conditions satisfactorily when firing coal as per the variations in the coal quality parameters.
- v) The selection and sizing of equipment and auxiliaries for steam generator shall be made taking into consideration the most adverse conditions of coal quality given above as relevant/applicable to such selection.
- vi) The steam generator and its auxiliaries shall be designed for efficient and trouble free operation when firing the range of coal supplies having the characteristics given above and any of the coals characteristics in between these. The steam generator and its auxiliaries shall also be capable of giving BMCR rating, as specified above and other operating capabilities matching the requirements of plant operating capabilities without any trouble and limitations, when firing the coals having the range of characteristics specified.

B) Fuel Oil

- i) The heavy fuel oils (heavy furnace oil/ HPS/LSHS)² having characteristics as given below shall be used for start-up, coal flame stabilization and low load operation of the steam generators. In addition, the light diesel oil (LDO) firing facilities shall also be provided for cold start ups of the steam generator(s).
- ii) The design and construction of the steam generator shall be suitable for firing the fuel oils mentioned above in any combination with coal.

² Applicable heavy fuel oils to be confirmed by the purchaser.



C) **Analysis of heavy fuel oils**

i) Analysis of heavy furnace oil

1.	Specification	:	Furnace oil conforming to IS:1593, heavy grade
2.	Average gross calorific value	:	10,000 kcal/kg
3.	Flash point	:	66°C minimum (PMCE)
4.	Pour point	:	20°C maximum
5.	Kinematic viscosity at 50 °C	:	370 centistokes
6.	Specific heat	:	0.5 kcal/kg/°C (average)
7.	Ash, % by weight	:	0.1 maximum
8.	Sediment, % by weight	:	0.25 maximum
9.	Sulphur, % by weight	:	4.5 maximum
10.	Water content % by volume	:	1.0
11.	Acidity	:	Nil
12.	Specific gravity	:	0.95 to 0.96 average

ii) Analysis of heavy petroleum stock (HPS)

1.	Acidity inorganic	:	Nil
2.	Ash, % by weight	:	0.1 maximum
3.	Flash point	:	66°C minimum
4.	Kinematic viscosity in cst at 50°C	:	500 cst
	at 100°C	:	50 cst
5.	Pour point	:	72°C (maximum)
6.	Sediment, % by weight	:	0.25 (maximum)
7.	Sulphur, % by weight	:	4.5 (maximum)
8.	water content, % by volume	:	1.0 (maximum)
9.	Calorific value	:	About 10,000 kcal/kg



iii) Analysis for low sulphur heavy stock (LSHS) fuel oil

1. Flash point : 75⁰C minimum
2. Pour point : 57⁰C maximum
3. Total sulphur (% by weight) : 1%
4. Gross calorific value : 10700 kcal/kg
5. Sediment (% weight) : 0.05% (typical)
6. Water content (% volume) : 1% max.
7. Viscosity (maximum):

Temperature (°C)	CST	Redwood No. 1
38	-	-
50	40	166
60	26	112
70	20	150 maximum
80	13.5	63
90	10.5	53
99	8.5	47.5
100	-	49.0
110	-	-

8. Specific gravity : 0.865 minimum
9. Ash content : 0.05% (by weight)
10. Specific heat : 0.65 kcal/kg/°C

iv) Analysis for light diesel oil (LDO) : As per IS:1460 (latest)

The design and construction of the steam generator shall be such as not to call for any other liquid or gaseous fuel than that mentioned above for purpose of operation of the steam generator at low load including initial ignition. High energy arc (HEI) igniters shall be used for ignition of HFO/HPS/LSHS fuel oil directly.

2.1.7 Cooling Water

Cooling water required for coolers, bearings, instruments etc. will be supplied from the equipment cooling water (ECW) system of the plant described in Section-4 of this specification.

2.1.8 Ambient Air

For the purpose of steam generator design, the ambient air temperature and relative humidity shall be taken as 27° C and 60% respectively, unless specifically mentioned otherwise for design and sizing of individual equipment/ auxiliary of steam generator.



The steam generator and its auxiliaries shall, however, also be so sized that they are capable of giving boiler maximum continuous rating (BMCR) within the range of ambient air temperature from 6^oC to 50^oC.

2.1.9 Limiting Parameters for Steam Generator Design

The steam generator design shall comply with the following limiting parameters with design coal firing, under stipulated ambient air condition i.e. 27^oC temperature and 60% relative humidity:

- i) Excess air at economiser outlet at TMCR load : 20% (minimum)
- ii) Flue gas temperature at air-heater outlet (corrected) at TMCR load : 125^oC (minimum).

The steam generator guarantees shall, however be as per the conditions stipulated in relevant section of the specification.

2.1.10 Minimum Load without Oil support for Flame Stabilization

The design of steam generator shall be such that it does not call for any oil support for flame stabilization beyond 40% BMCR load when firing any coal from the range specified, with adjacent mills in service and mill load not less than 50% of its capacity. This shall be guaranteed and demonstrated by the Contractor.

2.1.11 Cyclic Load Capability and Adoptability for Sudden Load Changes/ Load Throw Off

- i) To match the desired plant operating capabilities, the steam generator shall also be designed for regular cyclic/ two shift operation. The total number of start ups shall be as under:
 - a) Hot starts (less than 10 hours of unit shutdown) : 4000
 - b) Warm starts (between 10 and 72 hours of unit shutdown) : 1000
 - c) Cold starts (greater than 72 hours of unit shutdown) : 150
- ii) Under the above conditions, no portion of the steam generator and the associated systems shall be stressed beyond acceptable safe stress and fatigue levels and the design of steam generator and its pressure parts shall take care of above without affecting the life of equipment and pressure parts adversely.
- iii) Steam generator shall also be capable of satisfactory, stable and safe operation in case of rapid load changes in downward direction due to external disturbances or equipment malfunction. Under such conditions the system shall stabilise itself through proven concepts and controls and within the recommendations of National Fire Protection Association, USA (NFPA), Sections 85C, 8502 and 8503.
- iv) In case of sudden load throw-off, in worst case from 100% BMCR, the steam generator shall be capable of automatically bringing down the steam generating capacity to match with HP-LP bypass capacity of 60% BMCR. The bidder to indicate minimum load of steam generator to which it can be brought down under such condition, during short turbine outages or export load rejection, with a view to save fuel and reduce heat losses. The unit shall be capable to operate at house load conditions.



- v) In line with automatic run back capability of the unit load on loss of critical auxiliary equipments, the steam generator equipment and systems shall also ensure smooth and stable runback operation.

2.1.12 Operation without HP Heaters in Service

Steam generator shall be designed for continuous operation with HP heaters out of operation. The steam generator heat output under HP heaters out condition shall be equal to at least 100% BMCR heat output with HP heaters in service. Under this condition the superheater and reheater outlet steam temperature shall be maintained at rated values within the whole control range of steam generator load. Further, during such operation the metal temperature of various pressure parts shall not exceed the limits stipulated in their design/selection.

2.1.13 Operation with/ without Turbine HP- LP Bypass System

- i) As specified elsewhere, when unit trips under full load, HP-LP by-pass system will come into service. This will call for boiler operation in HP-LP bypass mode, with SH flow of 60% BMCR capacity and feed water temperature of 140°C at economiser inlet. For such condition the economiser shall be suitably designed to take a thermal shock of sudden change of feed water temperature from the rated value to approx 140°C. The superheater and reheater outlet steam temperatures, during such operation shall be maintained at the rated value without the metal temperature for various pressure parts exceeding the safe limits stipulated for their design/ operation.
- ii) Irrespective of the fact that HP-LP bypass system is provided for smooth start-up, fast loading and house load operation of the unit; the steam generator shall also be capable of start up without HP-LP bypass system in service, except in case of hot start-up.

2.1.14 Mode of Steam Generator Operation and Rate of Loading

- i) In line with the plant operating capability requirements, the steam generators shall be designed for both constant as well as variable pressure operation. Thermal design of steam generator and the selection of materials shall be suitable for both the operational modes.
- ii) The steam generators shall be designed for minimum rate of loading/ unloading mentioned below from 50% to 100% (TMCR) loads without compromising on design life of pressure parts.
- | | | | |
|----|------------------|---|---|
| a) | Step load change | : | Minimum \pm 15% |
| b) | Ramp rate | : | Minimum \pm 3% per minute under variable pressure operation |
| | | | Minimum \pm 5% per minute under constant pressure operation |

Bidder shall clearly bring out the max. rates of loading/ unloading achievable with steam generator offered and the corresponding limiting variations (\pm %) of boiler parameters such as throttle pressure, oxygen in flue gas, drum level, SH steam temperature, RH steam temperature, furnace draft, etc.



2.1.15 Provision for Future Installation of FGD System

- i) A flue gas desulphurisation (FGD) system may be installed by the purchaser in future to meet the requirements of pollution control.
- ii) Following provisions needs to be kept by the bidder for this purpose:
 - a) Suitability of duct between ID fan and chimney for future interconnection of FGD system with minimum modification.
 - b) The ducting and supporting structure to be designed to take care of future guillotine damper to be installed between the two tap offs before chimney.

2.1.16 Furnace

Furnace shall comply with following requirements at 100% BMCR with or without HP heaters out of service and with range of specified coals, under most stringent combination of operating conditions:

- i) Maximum net heat input (NHI) per unit plan area of furnace : 5×10^6 kcal/hr/m²
- ii) Maximum heat liberation rate : 1.1×10^5 kcal/hr/m³
- iii) Maximum burner zone heat release rate : 1.5×10^6 kcal/hr/m²
- iv) Maximum heat input per burner : 55.0×10^6 kcal/hr/burner
- v) Maximum furnace cooling factor : 1.8×10^5 kcal/hr/m²
- vi) Maximum furnace exit gas temperature (FEGT) : 60⁰C below minimum initial deformation temperature (IDT) of ash.
- vii) Minimum furnace residence time : 1.72 seconds. Selected furnace residence time shall be coal specific
- viii) Pressure withstanding capability : Minimum \pm 660 mmwc at 67% yield strength or maximum conceivable head of fans, whichever is higher.
- ix) No. of coal burner elevation to be fed from one mill : One
- x) Buckstay spacing : To ensure that its natural frequency is sufficiently away from the flame pulsation frequency.
- xi) Buckstay support : Self support from furnace walls with no interconnection with boiler structure.



- xii) Furnace bottom hopper : Designed for hopper with one third full of ash/ clinker with density of 1350 kg/m³ (minimum)

Definitions of acronyms/ terms used above:

- a) Burner zone is defined as the centre line distances between the top and bottom burner plus 3.05 meters of furnace height. Further, heat input is the input from coal.
- b) For FEGT, the furnace exit plane shall be defined as the plane above the furnace nose tip or the plane beyond which the transverse tube pitching is less than 600 mm whichever is positioned first in the flue gas path.
- c) Furnace cooling factor in kcal/h/m² is the ratio of NHI or heat available and effective projected radiant heat absorbing surface (EPRS). Calculated EPRS shall be reduced by at least 10% to account for deterioration of furnace walls surface condition due to fouling and slagging.
- d) NHI or heat available in furnace is obtained by considering the GCV of the fuel minus the radiation loss, unburnt combustible, moisture in the air, latent heat of moisture in fuel and that formed by combustion of H₂ in the fuel plus the sensible heat of combustion air (primary plus secondary air), all above 27⁰C.
- e) Furnace residence time shall be defined as the residence time of the fuel particles from center line of the top elevation coal burners to the furnace exit planes. For this purpose the furnace exit plane shall be defined as the horizontal plane at the furnace nose tip for two pass boilers.

2.1.17 Pressure parts

- i) The design of all pressure parts (tubes, headers, vessels etc.) shall be as per IBR or other international codes with the approval of the purchaser.
- ii) Design pressure of the boiler pressure parts shall be at least 1.05 times the maximum operating pressure, or as required by IBR/ other international codes, whichever is higher. For boiler drum, the design pressure shall be higher of the value as per (a) above or lowest drum safety valve set pressure for full discharge.
- iii) The thickness of the pressure parts (steam and water tubes/ headers, pressure vessels etc.) shall be calculated using IBR formulae/factor of safety etc. (and not as per codes/ formulae acceptable to IBR). Such thickness as per IBR formulae shall be arrived at after allowing for tube bend thinning allowance, where applicable as per IBR/ international codes. Additional erosion allowance on the calculated tube thickness shall be provided at specified locations as specified by the purchaser in these specifications.
- iv) In line with IBR, the maximum permissible temperature/ metal temperature for design of different components of the boiler shall be considered as below:
 - a) Economiser tubes : Maximum working water temperature plus 11⁰C.



- b) Furnace and boiler tubes : Saturation temperature corresponding to maximum working pressure plus 28⁰C.
- c) Superheater and reheater tubes in convection path : Maximum working steam temperature plus 39⁰C.
- d) Superheater and reheater tubes in radiation path : Maximum working steam temperature plus 50⁰C.
- v) Pressure part materials

Materials used for boiler tubing, headers, piping, vessels and other pressure parts shall comply with maximum permissible temperature limits for various materials as specified below:

- a) Upto and including 400⁰C : Carbon steel to ASTM 106 Gr.B/C or SA 299, SA 210C, SA 210Gr A1 or equivalent.
- b) Above 400⁰C and upto and including 550⁰C : Alloy steel to ASTM A335/ ASTM A213, P11/T11, P22/T22, P91/T91 or equivalent
- c) Above 550⁰C and upto 590⁰C : P91/T91, stainless steel grade to purchaser's approval.
- d) Above 590⁰C : P92/T92, stainless steel grade to purchaser's approval.

2.1.18 Superheaters and Reheaters

- i) Maximum average flue gas velocity in section/ tube banks with transverse tube pitching 600 mm or less and with 25% excess air at economizer outlet : 10 m/s (The maximum localised velocity across the cross section shall not exceed 12 m/s)
- ii) Minimum transverse pitch of elements in heating surfaces in the direction of gas flow :
 - a) 762mm in banks/ sections placed in area where gas temperature exceeds IDT for the range of coal specified.
 - b) 600mm in the banks/ sections where temperature exceeds FEGT [measured by multiple- shield high velocity thermocouple (MHVT)].
- iii) Means of temperature control:
 - a) Super heater : Spray water attemperation shall be tapped off from a suitable source upstream of HP heaters (from BFP discharge or Kicker stage outlet). The bidder can also tap off the spray water from a suitable location downstream side of HP heaters, provided, bidder has experience of such tapping, details of which shall be provided to purchaser.



- b) Reheater : Primary control
Tilting of burners/ gas recirculation/ gas biasing
- Secondary (emergency) control
Spray water attemperation (utilising water tapped off from interstage of BFP)
- iv) Maximum allowable spray water flow : a) For superheater : 8% of BMCR flow
(The steam temperature downstream of desuperheater shall have at least 10°C super-heat to ensure proper evaporation). However, the control valve shall be sized for 12% of BMCR flow.
- b) For reheater : Nil
(Reheater attemperation shall be used only under emergency conditions). However, the control valve shall be sized for 5% of the BMCR flow.

2.1.19 Economiser

- i) Type : Non steaming type, with parallel cross flow or counter cross flow arrangement
- ii) Approach temperature : 17°C (min.) at BMCR load. However, there shall be no steaming at part load and/ or sliding pressure operation.
- iii) Maximum average flue gas velocity through inter-tube space of the economizer banks (the gas velocity shall be calculated considering 25% excess air at economiser outlet) : 10 m/s (maximum localized velocities shall not exceed 12m/s)

2.1.20 Air Pre Heaters

- i) Type : Regenerative type tri-sector air pre heaters with facility of steam coil heating on secondary air side to guard against low cold end temperature.
or
Regenerative type bi-sector air pre heaters for primary air and secondary air with facility of steam coil heating both on primary air side and secondary air side to guard against low cold end temperature
- ii) Design ambient air : 27°C and 60% RH
- iii) Boiler load to be : a) 60% BMCR with worst coal and maximum moisture with one APH in service.
b) 100% BMCR with worst coal and maximum moisture with both APHs in service.



- iv) Minimum average cold-end temperature at 100% BMCR (with SCAPHs out of service) : 76⁰C
- v) APH sizing shall also ensure following (for whole range of specified fuels)
- a) Minimum flue gas temperature (corrected) at APH exit at 100% TMCR load with design coal firing : 125⁰C
- b) Air leakage : Less than 10% of the TMCR flue gas weight entering air-heater
- c) Minimum flue gas temperature at all loads : 5⁰C above acid dew point of flue gas

Sizing of air-preheater(s) shall also ensure that there is no need for economiser bypass to get the desired mill outlet temperature, for the whole range of specified coals.

2.1.21 Steam Coil Air Pre Heaters (SCAPH)

SCAPH shall be designed and sized to increase the air heater inlet temperature based on following criteria:

- i) Design ambient air temp. : 6⁰C
- ii) Number of SCAPHs : One(1) in secondary air by-pass duct after each FD fan for tri-sector type APH. In case of bi-sector type APHs, the SCAPHs shall also be provided for primary air in by-pass duct after each PA fan.
- iii) Air temperature at the inlet of each air pre heater (throughout boiler control range) : To keep average cold end metal temperature minimum 10⁰C above the acid dew point for flue gases
- iv) Design SCAPH and connected duct work suitable to handle flows corresponding to 50% BMCR loads without any undue noise/vibration.

2.1.22 Auxiliary Steam PRDS

The sizing of auxiliary steam PRDS shall be based on following:

Description	High capacity auxiliary PRDS	Low capacity auxiliary PRDS
i) No. of aux. PRDS/unit	1	1
ii) Source of steam	Main steam line	Cold reheat steam line



iii) Capacity	As per Note-1	As per Note-2
iv) Indicative parameters of steam on downstream sides	16 kg/cm ² (abs.) and 310°C	16 kg/cm ² (abs.) and 210°C

- Note: 1) The high capacity PRDS shall be sized for auxiliary steam requirement of the equipment in contractor's scope of supply with the unit running at 60% TMCR load plus start up auxiliary steam requirement of another unit plus auxiliary steam requirement of fuel oil system (in purchaser's scope).
- 2) The low capacity PRDS shall be sized for auxiliary steam requirements of the equipment in contractor's scope of supply with unit running at 100% TMCR load plus auxiliary steam requirement of fuel oil system (in purchaser's scope).
- 3) The requirements of auxiliary steam for fuel oil system in purchaser's scope shall be confirmed during detailed engineering.

2.1.23 Coal Firing System

A) Coal pulverisers (mills)

- i) The coal pulverizes shall be of vertical spindle ball and race type/ Raymond bowl mills/MPS mills or approved equivalent type.
- ii) No. of coal pulverizes to be supplied shall satisfy following requirements:

<u>Operating criteria</u>	<u>No. of coal pulverisers</u>
100% BMCR (worst coal firing)	N
100% BMCR(design coal firing)	N+1
100% TMCR(worst coal firing)	N+1

'N' is number of working mills required for respective operating criterion.

- iii) Selection of number of mills at various loads as specified above shall be based on following requirements, all occurring simultaneously:

Maximum permissible mill loading for selection of mill capacity/ type/model meeting requirements specified at A (ii) above.	:	90% of design capacity
Pulverised coal fineness at rated capacity of the pulveriser	:	70% thru 200 mesh (75 microns) and 98% thru 50 mesh (300 microns)
Input coal size	:	Upto 50 mm

- iv) Coal quality : As per specified coal



- v) Bidder shall guarantee the wear life of mill wear components (for whole range of specified coals) as per the table given below:

<u>Component</u>	<u>Guaranteed wear life in equivalent hours</u>
a) Classifier cone and other items lined with ceramic materials	: 25,000 hrs.
b) Classifier vanes	: 25,000 hrs.
c) Seals	: 20000 hrs.
d) Mill discharge valve	: 15000 hrs.
e) Grinding elements (rolls, balls, rings and race)	: 5500-8000 hrs.

The bidder shall indicate YGP (Yancey, Geer and Price method) index considered for design of wearing components, and shall furnish curves along with his offer indicating the variation in guaranteed wear life with variation in quality of coal fired. Separate curves for different wear elements of mill shall be furnished i.e. grinding rolls, balls, rings etc. The curve shall be subject to purchaser's approval.

B) Pulverised coal pipe

i) Velocity in coal pipe	: Minimum 15m/s Maximum 28m/s
ii) Continuous operating temperature for pipe design	: 110 ⁰ C (Minimum)
iii) Special erosion protection (on identified areas)	: Ceramic lining
iv) Guaranteed liner life	: 25000 Hrs.
v) Design pressure	: 3.5 kg/cm ² (minimum) as per NFPA requirement

C) Raw coal feeders

i) Type	: Gravimetric, belt type with minimum coal inlet pipe size of 36 inches
ii) Maximum moisture	: As per specified coal
iii) Feeder capacity	: Minimum 20% spare capacity over maximum mill capacity



- iv) Environment withstand capability as per NFPA norms : a) Operating pressure of 0.14 kg/cm²
b) Explosion pressure of 3.5 kg/cm² (minimum)
c) Ambient temperature 70⁰C (minimum)
d) Other environmental conditions envisaged

D) Primary air fans

- i) Type : Two stage axial type with rotor blade of aerofoil design.
- ii) Nos. of fans : Two (2) for each unit
- iii) Capacity:
- a) Each fan shall be rated to meet requirement of 60% BMCR load (one stream in operation) with following conditions all occurring together.
- Worst coal firing with maximum moisture content.
 - Power supply frequency - 47.5 Hz.
 - Ambient air temperature of 50⁰C and RH of 65%.
 - Air pre heater leakage of 15% or guaranteed value whichever is higher.
- b) Both fans working in any case the margins on flow and pressure shall not be less than 25% and 30% respectively over the calculated values at 100% BMCR condition. Above margin shall be under conditions indicated below all occurring together.
- Worst coal firing with maximum moisture content.
 - Power supply frequency - 50 Hz.
 - ambient air temperature of 50⁰C and RH of 65%.
 - Air heater air - in leakage of 10% or guaranteed whichever is higher.
 - All mills including standby mill shall be in service.
- iv) Speed : Maximum 1500 rpm
- v) Control : Blade pitch control
- vi) Location of silencer : At suction

E) Seal air fans

- i) Type : Centrifugal
- ii) Margin over and above the calculated values under maximum duty conditions : 25% in flow and 30% in head
- iii) Ambient air condition : 50⁰C dry bulb temperature and 65% RH



- iv) No. of fans : 2x100% common for all mills of one boiler
- v) Fan speed : Not to exceed 1500 rpm under test block condition

F) Coal burners

- i) Capacity :
 - a) To cater to 100% BMCR load
 - b) To ensure stable operation at and above BMCR with coal having lowest volatile matter without oil support.
- ii) Turn down ratio of each set from one mill : To be decided by contractor as per stable operation criteria detailed above subject to minimum of 2:1.
- iii) Special feature :
 - a) Low NO_x design.
 - b) Total NO_x emission (fuel as well as thermal NO_x shall not exceed 260 gms/giga joule of heat input to the boiler.
- iv) Control : Centralised automatic control with flame scanner and safety protection.
- v) Operation : Conforming to relevant NFPA guidelines.

2.1.24 Fuel Oil Preparation and Firing System

- i) Fuel oil preparation and firing system shall be designed common for both the units.
- ii) Type of fuel oil:
 - a) Startup fuel for cold start : LDO
 - b) Startup fuel for normal startup, low load operation, coal flame stabilization : HFO/LSHS/HPS
- iii) Minimum fuel oil firing capacity
 - a) For LDO : 7.5% BMCR heat input capacity
 - b) For HFO/LSHS/HPS : 30% BMCR heat input capacity
- iv) Oil burners
 - a) Type : Steam/air atomised with HEA ignitors



- b) Atomisation medium : Air for LDO and steam for HFO/LSHS/HPS
- c) Capacity : > To cater for 30% BMCR heat input with HFO/ LSHS/ HPS for load carrying and as oil support.
> To cater for 7.5% BMCR heat input with LDO for startup at cold start conditions.
- d) Turndown ratio : 4:1
- e) Control : Centralised automatic control with flame scanner and safety protection.

2.1.25 Draft Plant

The forced draft (FD) fans and induced draft (ID) fans shall be capable of maintaining balance draft conditions in the furnace over the entire load range with any one or both FD fans and any one or both ID fans in operation while burning the specified range of fuels.

<u>Description</u>	<u>FD fans</u>	<u>ID fans</u>
i) Type of fans	Constant speed axial	Variable speed radial/ constant speed axial
ii) Fan sizing criteria with all the following conditions occurring together	Each fan to be sized for 60% BMCR flow (one stream in operation) calculated taking into account following factors occurring together.	Each fan to be sized for 60% BMCR flow (one stream in operation) calculated taking into account following factors occurring together.
a) Type of coal firing	Design/best/worst coal whichever gives maximum FD fan air requirement	Design/best/worst coal whichever gives maximum flue gas flow.
b) Power supply frequency	47.5 Hz	47.5 Hz
c) Excess air	20% over stoichiometric air requirement	20% over the stoichiometric air requirement
d) Fan inlet air/ flue gas temperature	50 ⁰ C with 65% RH	Gas temperature corresponding to ambient air temperature of 50 ⁰ C and 65% RH
e) Air heater air-in leakage	10% or actual guaranteed value whichever is higher	Based on minimum 15% leakage from primary air and 10% leakage from secondary air or actual guaranteed values whichever is higher



Section- 2 (Steam Generator and Auxiliaries)

f)	Pressure drop through ESP	Not applicable	25 mmwc or actual guaranteed value whichever is higher
g)	Air-in leakage through ESP	Not applicable	1% or actual whichever is higher
h)	Pressure required at chimney inlet	Not applicable	+ 10 mmwc
i)	Air in leakage through duct	Not applicable	+2%
j)	Operating medium	atmospheric air	Flue gas
iii)	The fan shall also fulfil following sizing criteria in addition to that mentioned above (with both fans working):	Each fan to be sized for 50% BMCR flow calculated taking into account following conditions taken together:	Each fan to be sized- for 50% BMCR flow calculated taking into account following conditions taken together:
a)	Margin over 100% BMCR flow	20%	20%
b)	Margin over 100% BMCR pressure	44%	44%
c)	Type of coal firing	Design/worst/best whichever gives maximum FD fan flow	Design/worst/best coal whichever gives maximum gas flow
d)	Excess air at economiser outlet	20% over the stoichiometric air requirement	20% over the stoichiometric air requirement
e)	Fan inlet air/ flue gas temperature	50 ⁰ C with 65% RH	150 ⁰ C or actual whichever is higher corresponding to ambient air temp. of 50 ⁰ C and 65% RH
f)	Air heater in leakage	10% or guaranteed value whichever is higher	10% or guaranteed value whichever is higher
g)	Power supply frequency	50 Hz	50 Hz
h)	Pressure drop through ESP	Not applicable	25 mmwc or actual guaranteed value whichever is higher



- | | | | |
|----|--------------------------------------|----------------|--|
| i) | Air-in leakage through ESP and ducts | Not applicable | 1% through ESP and 2% through duct or actual whichever is higher |
| j) | Pressure at chimney inlet | Not applicable | +10mmwc |

(The sizing criteria specified above shall consider air heater and ducts in normally fouled up condition. The static pressure requirements only shall be considered without any credit for velocity pressure recovery.)

- iv) Air/flue gas flow control : Variable frequency/hydraulic coupling control for radial type fan and blade pitch control for axial type fans.

2.1.26 Flue Gas Ducts and Air Ducts

- | | | | |
|------|---|---|--|
| i) | Maximum allowable flue gas velocity (the velocity shall be calculated considering 25% excess air at economiser outlet, worst coal firing at 100% BMCR load) | : | 13m/s (before ESP)
16m/s (after ESP) |
| ii) | Maximum allowable air velocity (the velocity shall be calculated considering 25% excess air at economiser outlet, design/ worst coal firing at 100% BMCR load whichever gives maximum air/gas flow) | : | 16 m/s |
| iii) | Design pressure | : | ± 660 mmwc at 67% yield strength or maximum conceivable pressure of the relevant fans, whichever is higher. |
| iv) | Type of damper | : | a) Control damper: Pneumatic
b) Isolation : Electric/pneumatic, where fast closing is desirable from process point of view. |
| v) | Duct plate material | : | a) Minimum thickness 7 mm in the flue gas ducts. However, duct plate thickness of 5 mm from outlet of ESP to chimney can be considered provided the duct stresses remain in the normal range.
b) Minimum thickness 5 mm in the air ducts.
c) A corrosion allowance of 1.5 mm shall be considered for stress calculation for gas ducts. |

2.1.27 Electrostatic Precipitator Design Data

The electrostatic precipitator(s) shall be designed to comply with the requirements stipulated under 'guarantee point' and 'design point' in the table below:

Item	Guarantee point	Design point
i) Unit loading	100% TMCR	100% BMCR
ii) Type of coal	Design coal ash coal from range)	Worst coal (maximum ash)
iii) Ambient air condition	27 ⁰ C temp. and 60% RH	45 ⁰ C temp. and 60% RH
iv) Gas flow per steam generator at the ESP inlet when firing respective coal (m ³ /sec)	To be worked out by bidder when firing the specified design coal at TMCR load considering 25% excess air at economiser outlet, 15% air heater in leakage and 2% duct leakage as a minimum.	To be worked out by bidder when firing the specified worst coal with max. ash at BMCR load, considering 25% excess air at economiser outlet, 15% air heater in leakage and 2% duct leakage as a minimum.
v) Gas temperature at ESP inlet (⁰ C)	125 ⁰ C or as predicted by the bidder under conditions stipulated above, whichever is higher	140 ⁰ C or as predicted by bidder under conditions stipulated above, whichever is higher
vi) Inlet dust burden (gm/Nm ³)	To be worked out by the bidder (based on 85% of ash or actual predicted whichever is higher being carried forward to ESP while firing specified design coal.	To be worked out by the bidder (based on 90% of ash or actual predicted whichever is higher being carried forward to ESP while firing specified worst (maximum ash) coal.
vii) No. of series electrical fields out of operation	Nil	one each in all 4 passes
viii) ESP dust collection efficiency (%)	To be worked out by bidder to limit outlet dust burden (ODB) to 45 mg/Nm ³ (maximum) with all fields in operation.	To be worked out by bidder to limit outlet dust burden (ODB) to 80 mg/Nm ³ (maximum) with one field out of service.



ix)	Minimum specific collection area with one series of electrical fields out of operation ($m^2/m^3/s$)	180*	
x)	Maximum flue gas velocity through the ESP (m/s)	1.0	1.0
xi)	Treatment time of the flue gases (seconds) minimum	20	20
xii)	Other design parameters:		
a)	Minimum aspect ratio	1.5	1.5
b)	Design internal pressure at 67% yield strength (mmwc)	± 660	± 660
c)	Precipitator mechanical design temperature ($^{\circ}C$)	200	200
d)	Short temp excursion temperature (for approx. thirty (30) minutes at a time) ($^{\circ}C$)	300	300
e)	Minimum no. of transformer rectifier (TR) sets per stream per series electrical field	One (1)	One (1)
f)	Maximum collection area served by one TR set (m^2)	4000	4000
g)	Minimum no. of bus sections per TR set	One (1)	One (1)
h)	Minimum dust hopper storage capacity (upto the maximum trip level based on design point conditions (while firing worst coal (with maximum ash) (in hrs)	-	eight (8)
i)	Minimum hopper valley angle to the horizontal(degrees)	Sixty (60)	Sixty (60)
j)	Maximum spacing between * the collecting plates (centre line to centre line) transverse to the gas flow (mm)	400	400
k)	Minimum installed corona ** power per unit effective collection area ($Watts/m^2$)	17	17



l) Maximum nos. of ash hoppers	Two (2) for one TR set	Two (2) for one TR set
--------------------------------	------------------------	------------------------

Note :

- * The minimum specific collection area shall change in inverse proportion to the spacing between collecting plates i.e. for collecting plate spacing of 300mm, the minimum specific collection area shall be $240 \text{ m}^2/\text{m}^3/\text{s}$.
- ** The corona power shall be defined as the product of, average bus voltage and mean current divided by the collection area served by one TR set.

Bidder shall furnish the detailed calculations in support of ESP gas flow, inlet dust burden, ESP efficiency as offered by him both at ESP design and guarantee points during detailed engineering.



2.2 TECHNICAL REQUIREMENTS

The specified requirements shall be complied for the most stringent conditions resulting either from the range of coal (design/worst /best) specified or from the range of operating conditions specified (like 100% BMCR or HP heaters out of service or variable pressure operation or constant pressure operation etc. or from all occurring simultaneously) unless otherwise specifically mentioned.

2.2.1 Steam Generator Enclosure

- i) Steam generator enclosure shall form air and gas tight envelop from combustion air inlet point to chimney inlet to prevent infiltration of extraneous air in to the combustion chamber and gas passes.
- ii) The enclosure integral with boiler (except air heaters) shall be formed by water/steam cooling tubes using welded wall construction on all the four sides, roof and bottom. Where use of refractory is unavoidable, 4mm thick steel plate behind refractory shall be provided to form enclosure and any penetration (s) into the steam generator enclosure shall be sealed for gas tight integrity.
- iii) Seal plates of stainless steel (type 430) or better corrosion and erosion resistant steel material of minimum 6mm thickness all around the furnace bottom shall be provided to prevent ingress of air.
- iv) Dissimilar metal welds (DMW) between austenitic and ferritic steels, martensitic and austenitic steels, martensitic and ferritic steel shall be avoided inside the boiler enclosure for the pressure parts which are exposed to hot flue gases. However, if such DMW are unavoidable, same can be permitted at shop provided manufacturer has previous experience of such DMW and appropriate heat treatment is done after welding.
- v) In the steam generator enclosure, minimum $1.5 \pm 10\%$ m clear cavity height shall be provided in between the horizontal banks, sections of economiser, superheater and reheater for maintenance purpose.
- vi) The entire furnace shall be suspended from a suitable supporting structure to allow free expansion of surfaces and to prevent its distortion and dislocation of insulation. Thermal expansion of the furnace wall shall be in the downward direction.

2.2.1.1 Furnace and water walls

- i) Water/ steam walls shall be of membrane wall construction made from seamless tubes.
- ii) The height of furnace bottom shall be about 10 m above ground level and smaller side of opening for bottom ash hopper shall be 110 cm (minimum).
- iii) The thickness of water wall tubes shall be increased by minimum 0.6 mm over and above the calculated thickness as per IBR to account for tube erosion and corrosion. Further, an additional tube thickness of 1.0 mm over and above the thickness of water wall tubes as calculated above shall be provided on all water wall tubes coming within a radius of half a meter of each wall blower to guard against premature tube failure due to soot blowing. Alternatively, fasciated tubes may be provided in the soot blowing radius to guard against impact of soot blowing.



- iv) There shall not be any flame impingement on water walls.
- v) Headers shall be located external to gas path to the extent possible and as per the manufacturer's standard practice.
- vi) Minimum 10% thinning allowance shall be provided wherever there is bend in the tubes of furnace and water walls.
- vii) Minimum 10mm diameter carbon steel wear bar shall be welded on all the corners of the furnace bottom hopper (S shaped panel) up to three metres from the side and additional 0.5m vertical height for prevention of tube damage due to falling slag/ ash erosion.
- viii) Adequate numbers of furnace observation and tapping points shall be provided for local instruments, gauges, switches, test pockets etc.
- ix) In case water wall orifices are provided, these should be supplied with indexing holes and index pins.

2.2.1.2 Steam generator casing and framing

- i) The design of steam generator casing including pent house shall ensure:
 - a) The enclosure of steam generator shall be complete including superheaters, reheater and economisers headers.
 - b) The casing, pent house and its supporting system shall be capable of taking additional loads due to accumulation of ash in the pent house upto a height of 300 mm or actual expected (in between two annual overhauls of the units) whichever is higher. This additional load shall be over and above other loads considered for casing design. The ash density for the purpose of loading shall be at least 1350 kg/m³.
- ii) Steam generator casing including pent house shall have following features:
 - a) Rigid self containing structure with adequate stiffening.
 - b) Welded wall construction, sectionalised to allow easy removal/ replacement. However pent house may be bolted/screwed type and shall be easily removable.
 - c) Water proof/ tight construction under rains and winds with proper drainage system.
 - d) All drainage arrangement like gutters, drain pipes, connected to plant drain system at ground level.
 - e) Boiler roof arrangement of proven design and architecture.
- iii) At least two pent house ventilation/cooling fans with their air inlet opening at opposite ends, shall be provided.
- iv) The casing including pent house shall be provided with air tight access, observation and cleaning doors with frame having fire brickwork. Access alongwith platform shall be provided for easy and quick installation of scaffolding for furnace inspection/ maintenance.



2.2.1.3 Access and observation openings

- i) The steam generator shall be provided with adequate number of access and observation openings doors at different levels and at various positions as per the purchaser's approval. The doors shall be provided to permit access to the furnace, superheaters, reheaters, and other enclosed pressure parts and any other area requiring access. All doors shall be hinged and be air-tight. Suitable poke doors at the furnace bottom shall be provided for maintenance.
- ii) One of the access doors provided shall be suitable to take a power operated furnace tube maintenance cradle inside the furnace. This access shall be provided on one of the side walls and shall be such as to provide easy accessibility to introduce the maintenance cradle directly on the water wall hoppers, either in assembled condition or in dismantled condition to be assembled inside the furnace. Suitable number of openings in the roof superheater shall be provided to pull the maintenance cradle up and reach any place of all the water walls and pendent super-heaters to effect any repair on the tubes.
- iii) Design shall also include observations ports at various levels to facilitate observation of the furnace including inside surface of burners, ignitors, thermocouple connections and the burner flame.
- iv) All such openings e.g. manholes, peepholes etc. shall have suitable approach platforms and ladders from the nearest platform level. This shall assume easy and safe approach during operation and maintenance.

2.2.1.4 Drum

- i) Design code : IBR
- ii) Design temperature : As per IBR
- iii) Suitable moisture eliminators, screens and other internals, as necessary, shall be provided in the steam drum. The boiler water quality to be maintained shall not be inferior to the following limits:

• Phosphate ions	0.5 to 3 ppm
• Silica	≤ 0.25 ppm
• TDS	≤ 20 ppm
• Conductivity at 25 ⁰ C	≤ 50 μS/cm
• pH at 25 ⁰ C	9.2 to 9.4
- iv) Minimum six (6) nos. chromel alumel thermo couples shall be provided on drum for monitoring the drum metal temperature.
- (v) Boiler drum construction shall have:
 - a) Fusion welded construction with welded hemispherical dished ends. 100% radiography shall be done for all longitudinal and circumferential welds.
 - b) Nozzles for steam and water connections and tappings for instrumentations,



- sampling and other mountings and fitting etc.
- c) Connections for chemical dosing and nitrogen preservation.
 - d) Nozzles and tappings to comply with heat treatment, weld and other requirements as per ASME Section-I/ BS 5500/ IS 2825.
 - e) Manhole with forged steel cover.
- vi) The quality parameters of saturated steam shall be as per requirement of the turbine manufacturer. However, the same shall not be inferior to the following under all operating conditions:
- a) Silica carry over : <15 ppb
 - b) Sodium carry over : <5 ppb
 - c) Copper carry over : <3 ppb
 - d) Iron carry over : < 20 ppb
 - e) Conductivity at 25⁰C : < 0.2 μ S/cm

2.2.1.5 Boiler circulation system

- i) Boiler circulation system shall be of assisted circulation type.
- ii) Functional requirements:
 - a) Boiler circulation system shall be designed for adequate circulation ratio during rapid start-up and load changes to prevent overheating of the water wall tubes with maximum possible heat flux in the furnace.
 - b) Boiler circulation pumps of suitable size shall be provided to meet the reduced available differential head between steam and water owing to high pressure operation of the boiler.
- iii) Specific requirements:
 - a) Number of pumps : 3x50% (two working + one standby, each pump shall be sized for 60% BMCR load requirement).
 - b) Type of pumps : Vertical type heavy duty gland less, zero leakage type, hermetically sealed
 - c) Motor specification :
 - Motor shall be wet type, specifically designed for the application and shall be as per standard adopted by the pump manufacturer subject to purchaser's approval.
 - Motor windings shall be of non- hygroscopic material and shall be designed to withstand continuous water pressure and temperature variation.
 - The insulation shall have sufficient dielectric strength to withstand rated phase to earth voltage in slot portion and phase to phase voltage in end windings.

- The insulation material shall not have any tendency to plastic deformation even under extreme operating condition of conductor temperature, mechanical forces, vibrations etc.
 - The cooling circuit shall be provided with a reflux pressure compensation drums at the bottom of the water wall to guard against any rise in pressure, if required.
 - Power and instrumentation leads shall be taken out of the motor through water tight sealing glands and shall be run in flexible metal conduits or metal cable sheathing along the length of the pump body.
 - The design of the seals shall allow for effects of differential expansion between insulation conductor and pressure casing, over the entire range of operating temperature.
- d) Cooling system : 2x100 % external high pressure coolers shall be provided with 2x100 % capacity filters for each pump set to remove the heat generated by the motor and bearings during operation. A high temperature motor cavity alarm/ trip shall be provided. The design shall be such that during hot standby service of the pumping unit, sufficient cooling effect is provided by natural circulation of the coolant so as to prevent over heating of the motor.
- e) The circulation pumps and motors shall be provided with necessary handling arrangement including runway beams, trolleys etc. Further, special T&Ps like stud tensioners and gang jacks shall be provided.
- f) Construction requirements:
- Pumps and motors shall be hermetically sealed.
 - The design and construction shall be heavy duty type suitable for operating pressure and temperature.
 - Pumps shall be mounted and supported directly from the boiler circulation piping system.
 - Motor shall be mounted beneath the pump.
 - Pump casing shall be one piece casting with end suction and dual side discharge.
 - Impellers shall be of one piece casting secured to the shaft in over hung position on the extension of the motor shaft.
 - Impeller mounting shall allow the hub to freely expand and contract independent of the shaft.



- Materials selected shall cause minimum erosion and corrosion, and shall also eliminate electrolytic action.
- Common shaft of the pump and motor shall be guided and supported on spherically seated journal guide bearings and spherically seated tilting pad type double action thrust bearings, respectively.
- All bearings shall be lubricated by liquid in motor cavity.
- Bearing material shall be leaded bronze impregnated with polytetra fluora ethylene.



2.2.2 Super Heaters and Reheaters

2.2.2.1 Superheater(s) and reheater(s) shall be designed, suitably sectionalised and positioned to comply with the requirements of the specified load(s), coal(s) and whole range of operating conditions.

2.2.2.2 Construction of superheater(s) and reheater(s) shall have following features:

i) Heating surfaces arrangements:

- a) Tubes, banks, sections shall be made from seamless tubes and shall be drainable to the maximum possible extent.
- b) Even temperature distribution shall be ensured at gas and steam side by criss crossing the steam paths between LHS and RHS.
- c) Use of girdling loops shall not be allowed. .
- d) Elements shall be uniformly spaced to avoid gas bypassing.
- e) Use of radiant wall superheater or reheater shall not be allowed.
- f) Minimum clear spacing between any two sections of horizontal tube banks shall be 1500 mm.
- g) Maximum depth of tube bank sections in the direction of gas flow shall be 2 meters or maximum soot blowing radius whichever is lower.

ii) Supporting arrangement

All horizontal surfaces shall be supported by steam cooled hanger tubes. The hanger tubes shall not hamper the access to any part of heat transfer surfaces. Horizontal surface support by water cooled hanger tubes is also acceptable provided the contractor has proven experience with the same.

iii) Arrangement of headers

Headers shall be located out side the gas path to the extent possible and shall be fully drainable. Wherever locating the headers in the gas path becomes unavoidable, these shall be suitably protected with erosion shields. Further, the nipples and studs of the header shall be provided with wear resistant stainless steel shields of minimum 2mm thickness. The arrangement of header shall be such that it does not cause the high localised flue gas velocity zones near tubes downstream side of the header. The established design practices of the manufacturer shall be given due credence.

iv) Attemperators

Attemperators shall be made from corrosion/ erosion resistant steel, and shall be fitted with removable liners. These shall be located at inlet or between the two stages of superheaters and reheaters.



- v) Minimum tube thickness
 - a) Leading tubes of each bank shall be provided with additional thickness of minimum 1.0 mm as erosion allowance over and above the calculated thickness as per IBR.
 - b) Balance of tubes in the bank shall be provided with additional thickness of minimum 0.6 mm as erosion allowance over and above the calculated thickness as per IBR.
 - c) Minimum thinning allowance of +10% shall be provided on bends in addition to the above.

- vi) Tube and header materials

The materials shall be appropriate for most adverse operating conditions and as per design criterion at clause 2.1.17 (Alloys containing molybdenum only without any suitable stabilization with vanadium and chromium shall not be used. Total content of molybdenum, tungsten, silicon, vanadium, titanium, tantalum etc., individually or all together, if not otherwise specified, shall not exceed the limits specified in relevant material codes).

- vii) Maximum number of material grades that can be used in one tube bank shall be limited to three (3).

2.2.2.3 Superheater(s)/ reheater(s) design shall cater to the operation requirements as elaborated at clause 2.1 throughout the control range, for specified fuel and under all operating conditions like variable and constant pressure operations, HP heaters out of service, HP-LP bypass operation, top mills in service etc.

2.2.2.4 The steam generator design shall ensure that rated RH outlet temperature is achievable for the entire range of operation by use of primary control device only, while firing from the specified range of coals and all the following operating conditions:.

- a) Normal operation.
- b) Operation of steam generator with reduced feed water inlet temperature during the conditions of HP heaters out of operation and/or HP-LP bypass operation.
- c) Continuous operation of steam generator at BMCR conditions.
- d) Unit start-up.
- e) With middle mill combination at 100% TMCR load.

The RH spray water shall, however, be used for temperature control in case of emergency conditions.

2.2.2.5 Bidder to ensure that no damage is caused to the reheaters with sudden closure of turbine interceptor valves.

2.2.2.6 For continuous temperature monitoring, minimum nos. of thermocouples as per following shall be provided:



- a) For superheaters and reheaters elements placed before furnace exit plane (in the direction of gas flow), chromel-alumel thermocouples on at least two elements of every fifth assembly between the two headers shall be provided for tube metal temperature detection out of gas path (in SG casing).
- b) In addition to the above, adequate number of chromel-alumel thermocouples for measurement of tube metal temperatures outside the gas path shall also be provided. Total number of thermocouples including those at (a) above shall, however, not be less than 2 (two) thermocouples per RH/SH assembly between the two headers.

2.2.2.7 For maintenance and inspection of SH and RH, the following shall be ensured:

- a) Minimum 1.5 m clear cavity height between two sections/ banks of heat transfer surfaces for personnel access. For vertical surfaces, minimum clearance between the two banks shall be 600 mm.
- b) Access opening shall be provided alongwith air/ gas tight hinged door for approach to above maintenance spaces without any hindrance from hanger tubes. All access doors shall be of 500x500 mm size (minimum) and access doors above 0.8 m from the nominal floor level shall have access platforms. Hanger tubes of horizontal banks shall have access opening for crossing.
- c) Stainless steel erosion shields shall be provided for all bends of all SH and RH sections and hanger tubes in areas where flue gas temperature is below FEGT. For the pendent tube sections, the erosion shields on the leading tubes and wherever else considered necessary by the bidder as per his proven practice shall be acceptable.
- d) Arrangement shall be provided for internal inspection of attemperators.
- e) Arrangement of structural steel, runway beams, motorised hoists, walkway platform etc.) shall be provided for removing, handling and placement of tubes banks/section at ground level for repair and replacement.
- f) Headers and pipes if made of using X20 Cr Mo V 12-1 material shall have provisions to ensure that no site welding of this material with similar or dissimilar material is needed.

2.2.3 Economiser

2.2.3.1 In addition to the sizing design criteria requirement elaborated at clause 2.1, economiser design shall confirm to the following criteria and requirements under all conditions of operation and for the complete range of specified fuels.

<u>Criteria</u>	<u>Requirement</u>
i) Economiser tube thickness :	a) Erosion allowance of minimum 1 mm in addition to IBR requirements and b) Minimum 10% thinning allowance on bends, in addition to above.
ii) Maximum allowable tube metal skin temperature :	400 ⁰ C

2.2.3.2 Constructional features

- i) The economiser shall be bare tube and inline type, arranged for counter flow of feed water and flue gases with modular construction. It shall be fabricated from seamless tubes in suitable modules to facilitate block erection.
- ii) Stainless steel erosion shields shall be provided with for the leading tubes of each tube bank of the economiser. Minimum 5 mm thick sturdy cassette baffles shall be provided for all front and rear bends of the economizer banks. The cassette baffles shall cover complete bends and additional 300 mm straight tube length.
- iii) Steam/ water cooled hanger tubes/headers supporting the economiser shall form part of steam/ water circuit such as not to cause any dislocation /damage to the tube banks/setting.
- iv) Clear side spacing (gas lane) of minimum 63.5 mm shall be provided with proper barriers to avoid gas laning.
- v) Ash hoppers shall be provided for the economiser.
- vi) No valve shall be provided in the piping from economizer outlet to boiler drum.
- vii) If the steam generator has the flue gas downflow section with horizontal tube banks, the top most row shall be shielded to reduce erosion.
- viii) Headers shall be located external to gas path and shall be drainable to the maximum possible extent. If locating headers in gas path becomes unavoidable, than suitable erosion shields must be provided.
- ix) The economiser header shall be provided with drains and suitable opening with forged weld on caps for internal inspection and chemical cleaning.



2.2.3.3 Maintenance requirements

- i) Clear cavity height of minimum 1.5 m shall be provided between two sections/ banks of the economiser for maintenance access.
 - ii) Access/opening alongwith air/ gas tight hinged door shall be provided for approach to each tube bank.
 - iii) Necessary walkways, platforms, runway beams, motorised hoists etc. shall be provided for removing, handling and placement of complete tube bank/section at ground level for repair and replacement.
- 2.2.3.4 Space provision shall be provided on gas inlet side of the economiser for future addition of minimum 20% economiser surfaces. Structures and hangers shall be designed considering loads due to these additional surfaces also.



2.2.4 Air Pre Heaters and Steam Coil Air Pre Heaters

2.2.4.1 Air pre heaters (APHs)

- i) In addition to sizing and design criteria requirements elaborated at clause 2.1, the air preheaters shall be designed to cater to following requirements also:
- | | |
|--|---|
| a) Type | Regenerative type. |
| b) No. of air preheaters per steam generator | Two tri-sector type APH or two bi-sector type APH each for primary air and secondary air. |
| c) Air temperature at APH outlet | Adequate to attain the required coal/air mix temperature at burner inlet and to provide combustion air at required temperature to furnace at all loads and full range of specified coals. |
- ii) Air and flue gas ducts at inlet and outlet of APH shall be of aerodynamic design to ensure uniform flow distribution across the duct sections at all loads.
- iii) The air pre heaters shall be of rotary regenerative, Lungstorm or approved equivalent type with axis of rotation as vertical. The construction of air pre heaters shall conform to the following:
- | | |
|--|------------------------------------|
| a) Heating Elements | |
| • Cold end | Corten steel, minimum 1.2 mm thick |
| • Hot/ intermediate end | Carbon steel, minimum 0.8 mm thick |
| b) Bearings (forced lubricated and oil cooled) | |
| • Cold end | Spherical roller thrust bearing |
| • Hot end | Radial guide bearing |
- Only metallic hoses shall be used for bearing cooling and lubrication. Rubber hoses shall not be acceptable.
- c) Air heater seals
- The seals shall be of externally adjustable and easily replaceable type.
 - The maximum air-in leakage to flue gas after 3000 hours continuous operation of the boiler with coal shall be guaranteed and demonstrated. The contractor shall also demonstrate that the drift in air heater leakage (percentage change in air-in-leakage) does not exceed 2%, subject to a maximum air leakage of 12%, one year after demonstration of above guaranteed air-in-leakage. Within this period of operation till all air heater leakage demonstrations are completed only external adjustments of seals without needing any shut down for replacements or internal adjustments shall be allowed. The seal design/construction shall be such that the above requirements are satisfied.



- Seals shall have life not less than 2 years (with leakages not exceeding permitted limits)
- d) Air heater drive system
- The drive system shall consist of one (1) no. peripheral AC drive with gear box and automatic clutching/ declutching facility, and one (1) no. independent air motor drive with its gear box and automatic clutching facility for rotation during non availability of AC drive system. An air receiver of storage capacity to cater to 10 minutes (minimum) operational requirement of air motors shall be provided.
- iv) Ash hoppers shall be provided for collection of ash.
- v) The rated air temperature exiting the air heater shall be achievable upto 100% BMCR load with design coal.
- vi) Facilities along with the grids for flue gas sampling and gas temperature measurement on both the inlet and outlet sides of APH(s) shall be provided.
- vii) Alarms for failure of drives and lubrication system shall be provided.
- viii) Air pre heater rotor standstill sensing device with alarm shall be provided.
- ix) Air pre heater off load water washing facilities (including hoppers, water connections etc.) with drainage connected to station drains shall be provided.
- x) Air heater elements shall be arranged in baskets and shall be easily removable in groups/baskets for maintenance.
- xi) Observation ports with vapour proof light shall be provided at air inlet duct for rotor inspection.
- xii) Maintenance facilities:
- a) The arrangement of walkways, platform, runway beams, trolley, hoists etc. as required, shall be provided conveying, lowering and placement of elements/baskets to ground level.
 - b) Hinged access doors shall be provided in the housing for internal inspection, cleaning, maintenance and replacement of elements without dismantling air heaters.
 - c) Galleries and platform around air heater and access to observation ports/access doors etc. shall be provided. Platforms shall be capable of taking load and storing elements for at least one sector of the air pre heater.
 - d) Special T&P kit shall be provided for removal of bearings and for replacement of shaft.
- xiii) Permanent firefighting facilities alongwith thermocouple type fire sensing device and redundant temperature elements shall be provided for each bearing and oil sump. Fire fighting facilities on cold end and hot end of the air preheaters shall be provided and the fire fighting facilities shall cover both flue gas sides of air preheaters. Connections for fire water shall be taken from fire water lines in the purchaser's scope. Necessary water draining system, connected to station drains shall also be provided.



2.2.4.2 Steam coil air pre heaters (SCAPHs)

- i) SCAPH and connected air ducts shall be designed to handle flows corresponding to 50% BMCR loads with one of the two streams working without any undue noise/vibration.
- ii) Condensate from SCAPH shall be led to intermittent blow down (IBD) tank.
- iii) SCAPH shall have modular construction with adequate tube spacing to avoid chocking by contamination in the entering air.
- iv) SCAPH shall be located in the bypass duct at the outlets of each FD fans. For bi-sector type APH, SCAPH shall also be provided in the bypass duct at the outlet of each PA fan.
- v) Facility shall be provided for complete isolation of SCAPH from the air flow path.
- vi) SCAPH should be in service only during startup, low load and under abnormal conditions. It shall not be in service under all normal operations for the complete specified range of fuel.
- vii) The construction shall be of side entry type to facilitate removal of SCAPH modules by sliding out of modular frame.
- viii) Proper approach to the side entry and adequate facility (platform, runway beam, hoist etc.) for removal and placement of SCAPH modules on ground level shall be provided.



2.2.5 Coal Preparation and Firing System

2.2.5.1 General

- i) The coal preparation and firing system shall commence with the shut-off valve/ gate at raw coal bunker outlet and shall include raw coal feeders with shut off gate at inlet, coal pulverisers, primary air and seal air fans, pulverised coal piping, coal burners and associated auxiliaries.
- ii) The design of coal preparation and firing system shall ensure the following:
 - a) Complete safety of the plant, equipment and the personnel.
 - b) Complete compliance with the latest NFPA (USA) requirements and other requirements specified hereinafter.

2.2.5.2 Coal shut off gates/ valves and coal chutes

- i) Bunker shut off gate(s) and coal feeder inlet gate(s) shall be provided with the following features:
 - a) Size of gates/valves shall be suitable for round bunker opening of minimum 914.4 mm (36”).
 - b) Shut off gates/valves shall be motor operated, with double rack and pinion drive arrangement and shall be of non-jamming type.
 - c) Gate/ valve design shall ensure dust tight enclosure and shall be of self cleaning type.
- ii) All components coming in contact with coal and the roller bearing shall be of stainless steel material.
- iii) Shut off valves/gates shall be designed to operate with “bunker full of coal” condition without its motor getting overloaded. Normal motorised as well inching operation of these shut off gates/valves should be possible from the feeder floor. For manual operation from feeder floor level, wheel and chain shall be provided for each gate/valve.
- iv) The chutes between bunker outlet gate and inlet to the coal feeder shall not have internal diameter less than 914.4 mm. The chute between feeder outlet and pulveriser inlet shall not be of internal diameter less than 600 mm.
- v) The chutes shall be of made of minimum 12mm thick SS-410 material and shall be of fully welded construction. The chute between feeder outlet and pulveriser inlet shall have a SS lined hopper with suitable reinforcement. The provision shall be made for the insertion of poke rods in two direction opposite to each other at outlet of the bunker and inlet of the feeders.
- vi) Suitable coupling (Dresser or equivalent) shall be provided for chute connection(s) at outlet of feeder and pulveriser with SS 410 inner ring.

- vii) The arrangement of permanent bunker emptying chute alongwith necessary coal flow diversion valve shall be provided between each bunker and RC feeder. Necessary access shall be provided for operation of coal flow diversion valves. The emptying chute shall enable unloading of bunkers on trucks at ground level. An arrangement with a temporary chute fitted on the bunker downspout alongwith a permanent chute from the feeder floor to the ground level shall also be acceptable.
- viii) Suitable indicators shall be provided in the downspout between bunker and feeder to detect presence of coal flow to ensure minimum seal height at inlet to feeder and trip the feeder if the level of coal tends to be below the seal height.

2.2.5.3 Raw coal (RC) feeders

- i) The raw coal feeders shall be of gravimetric, belt type with minimum size of 914.4 mm (36"). Each RC feeder shall be sized for 1.2 times the maximum capacity of coal pulveriser. The feeder casing shall be designed to withstand an explosion pressure of 3.5 kg/cm²(g).
- ii) The RC feeders shall comply with all the stipulations of NFPA.
- iii) The feeder belt shall be of multi-ply reinforced rubber of single piece construction with arrangement for tracking and to prevent spillage. The width of the belt shall have sufficient margin while operating in conjunction with feeder inlet opening. Suitable arrangement shall be provided to adjust belt tension.
- iv) All components coming in contact with coal (except belt) shall be made of stainless steel.
- v) All site equipment shall be suitable for 70⁰C ambient temperature and other environment conditions envisaged.
- vi) Detection for "No coal" flow shall be provided to stop the feeder when no coal is detected on the conveyor and when pluggage occur at feeder outlet. Paddle type coal alarm switch shall be provided for this purpose over the feeder conveyor for indication of loss of coal flow and near the feeder discharge to stop the feeder in the event of coal pluggage at the feeder outlet.
- vii) The feeder control system shall be microprocessor based. Coal weighing shall be automatic and shall include local and remote indication for rate of flow and totaliser counter. The feeder control cabinet shall be located in control equipment room (CER).
- viii) The weighing accuracy of the feeder shall be $\pm 0.5\%$ with repeatability of 0.1%. Facility for in-built calibration shall be provided.
- ix) The following facilities shall be provided for the feeders:
 - a) Spraying water inside the casing.
 - b) Providing purge air to the feeder.



- x) Feeders shall be provided with adequate number of manholes on for quick and easy release of the feeder jamming. Easy access to any part of the feeder internals shall be possible without dismantling the complete casing.

2.2.5.4 Coal pulverisers (mills)

- i) Pulveriser type:

The coal pulverizes shall be of vertical spindle type. The pulverisers offered by the bidder can be of Ball and Race/ Roller/ Bowl/ MPS type or approved equivalent type.

- ii) Classifier design:

- a) The classifier design shall be of static type and shall be capable of maintaining rated conditions of fineness under all conditions of operation, load changes and specified fuels. Further, the classifier vanes shall be adjustable externally and shall be lined with suitable wear resistant material to ensure the guaranteed wear life.

- b) The classifier shall ensure reduction in particle of 50 mesh without increasing 200 mesh percentage to ensure uniform sizing and distribution of particles. Fineness adjustment shall be possible while the mills are in service.

- c) Outlet of the classifier shall have aerodynamic shape to prevent eddies.

- iii) Provision shall be provided in the mill design for future accommodation of rotary classifier in place of stationary classifier. For this purpose necessary structure, piping, spare piece etc. shall be provided.

- iv) Mill noise level:

The mill noise level shall not exceed the specified values. While selecting lagging, background noise from adjacent mills, drive system and other secondary and stray noises shall be taken into account.

- v) Mill seal air system:

- a) 2x100% seal air fans common for all the mills shall be provided for each steam generator unit. The fans shall preferably be located at ground floor.

- b) The sealing system shall prevent ingress of any dust into the bearings and leakage of coal-air mixture to atmosphere.

- c) The seal air fans shall take their suction from atmosphere/ PA fan cold air bus. Silencers shall be provided, if required, at the suction of the fans to restrict noise level within permissible limits.

- vi) Mill gear box:

The gear box shall be planetary type. The gear box design shall ensure that there is no ingress of coal dust into gear box under all conditions of operation. The gear box shall give trouble free operation of not less than 100,000 hours of mill operation.



vii) Mill motor capacity:

The mill motors shall be adequately sized and selected motor capacity shall enable restart of the mill after a trip with mill full of coal. Such restart shall not call for any emptying of the mill.

viii) Inlet coal pipe between RC feeder and the mill shall not have any reduction in section throughout the length, including at entry point on top of the mill.

ix) Each mill shall be fed with coal by an independent coal feeder.

x) Materials of construction:

a) The material of construction of wear parts shall be selected taking into account highly abrasive nature of coal resulting from coal contamination with silica sand and alpha-quartz.

b) The grinding rings/ race shall be made of material having hardness of minimum 550 BHN at the surface with adequate chilled depth. The grinding balls/ rolls shall be of material with minimum hardness 350 BHN. Minimum difference between hardness of rings/race and balls/rolls shall be 100 BHN.

c) The classifier cone shall be lined with minimum 15 mm thick ceramic tiles on both inside and outside surfaces of the cone. The classifier vanes shall be lined with suitable material to provide minimum specified wear life.

xi) Lubrication system:

The design of lubrication system shall ensure continuous operation of mill bearings. Suitable arrangement shall be provided for readily determining the oil level in the gear box(es) and all other lubricated parts.

xii) Pulverised coal sampling:

a) Tapping points shall be provided on each pulverized coal pipe at mill outlet and shall be suitable for coal sampling as per ISO 9931. The sampling provisions shall be complete with screwed plugs, compressed air purging connections at tapping points, heating arrangement and other requirements as per ISO 9931.

b) One (1) no. of Rota probe shall be provided for each steam generator for coal sampling as per ISO 9931. Further, four (4) nos. of Dirty Pitot tubes shall be provided for steam generator and shall be suitable for measurement of coal-air velocity in the coal pipes.

c) Convenient approach/access from nearest platform floor shall be provided for coal sampling/ measurement points.

xiii) Mill outlet temperature control shall be capable of achieving and maintaining rated temperature for adequately drying the specified coal range for all unit loads.

xiv) The flap of power operated mill discharge valves shall be totally out of coal path during operation of the mill.



- xv) All mill wear parts shall be arranged so as to facilitate easy replacements without total dismantling of pulveriser(s).
- xvi) The mill shall be capable of running at part loads and ensure minimum turn-down ratio of 2:1.
- xvii) Handling of pulveriser parts:
 - a) The pulveriser shall be designed to facilitate ease of handling of heavy parts for maintenance purpose.
 - b) Motorised hoists shall be provided for O&M works of components below separator top.
 - c) The gear case shall be accessible and suitable for removing gearing/ removing upper structure.
- xviii) Adequate numbers of access doors/windows with access ladders shall be provided to facilitate access to various parts of mill. The access doors shall be suitable for on load inspection and maintenance of the mill. The oil pumps and filters shall be readily accessible.
- xix) Necessary ladders and approach platforms for mill bay hoist shall be provided at one end/ corner to carry out any maintenance activity on hoists.

2.2.5.5 Pulverised coal pipes

- i) In addition to sizing and design requirements elaborated for pulverized coal pipes at clause 2.1, the following requirements shall also be adhered:
 - a) The design and arrangement of fuel pipe shall ensure uniform distribution of coal air mixture between all burners served by one pulveriser under all conditions of loading.
 - b) The maximum permissible design stress shall be 67% of yield strength (or 0.2% proof stress).
 - c) The coal air mixture velocity in the coal pipes shall not be lower than the critical fallout velocity under all conditions of mill operation from start up of boiler onward.
 - d) The fuel pipe shall preferably have no horizontal run and if horizontal run is necessitated due to layout constraints it shall tilt either towards mills or burners.
 - e) The pipe and bend base material thickness wherever liners are provided shall not be less than 8 mm.
 - f) The straight unlined pulverized coal pipe length shall be of mild steel having a thickness not less than 12.7 mm with a minimum wear allowance of 4 mm.



- g) Calculated static loading of each support of the pulverized coal pipes shall be increased by at least 25% to arrive at the design load, to take care of the shock loading, occurring in the pipe work under abnormal conditions of operation.
- ii) The guide plates, wherever provided in the coal pipe, shall be removable and access to them shall be obtained through detachable cover. The guide plates shall be made up of suitable abrasion resistant material.
- iii) The following pulverized coal piping portions shall be ceramic lined:
 - a) From mill outlet upto and including 1st bend and two times pipe diameter straight length down stream of first bend.
 - b) All bends between 15⁰ and 30⁰ angle and straight length down stream of the bends equivalent to one pipe diameter.
 - c) All bends 30⁰ and higher and two times diameter straight length downstream of the bend.
 - d) The burner inlet elbow and the pipe piece after the elbow.
 - e) Pulverised coal pipe from mill to classifier (in case of separate classifier).

The ceramic material shall have alumina content of not less than 90%. The ceramic lining shall be minimum 15 mm thickness and shall provide guaranteed life of 25000 hrs.

- iv) Purge air connections shall be provided after the mill discharge valve to clean pulverised coal pipes of any deposits etc.
- v) Provisions shall be made at suitable locations on pulverized coal piping for sampling the pulverized coal. Suitable sampling equipment shall also be provided.



2.2.6 Coal Burners

2.2.6.1 Burners design

- i) Turn down ratio of coal firing system shall be 2:1 (minimum).
- ii) The coal burner design shall ensure a steady log mean density of coal air mixture distribution as it enters the combustion zone, without allowing the coal dust to settle down.
- iii) The burner design shall minimise erosion.
- iv) The burner shall be designed to ensure smooth variation in the fuel flow without affecting the air to fuel ratio.
- v) The air to fuel ratio around the burner shall be optimized to ensure low emission of NO_x. Total NO_x emission (fuel as well as thermal NO_x) shall not exceed 260 gm/giga joule of heat input to the boiler.
- vi) Burners shall be provided with centralised automatic control with flame scanner and safety protection.

2.2.6.2 Burners construction

- i) Each coal burner shall be served by one separate coal pipe and shall be provided with one knife edge type gate valve at burner inlet. The valve shall be power operated and hooked up to burner management system.
- ii) Compartmented wind box shall be provided for supply of secondary air for combustion.
- iii) The material and construction of burner shall withstand radiation from the furnace, and shall not be damaged when not in use.
- iv) The parts subjected to high temperature which cannot be protected by other means shall be made of alloy steel. Further, burners parts subject to abrasion that may require replacement at frequent intervals shall be easily removable.
- v) Burner design shall ensure freedom from deposits and distortion under all operating condition in the furnace. Further, burners shall not require adjustment to maintain flame shape.
- vi) Minimum operating life of burner parts without requiring any maintenance and replacement shall be guaranteed for minimum 8000 hours.
- vii) Burner shall be removable or replaceable from outside the steam generator without entry to the furnace.

2.2.6.3 Air register construction shall be such that tangential air vanes are always free to move. The support bearings shall preferably be located outside. In case the support bearings are located inside, minimum period of operation shall be 16000 hours without calling for maintenance of any sort during this period.

2.2.6.4 The angle at confluence between the coal burner primary air and secondary air shall be such that the inherent carbon monoxide produced is removed by scrubbing action without any significant reduction in velocities of the air stream.

2.2.7 Primary Air Fans

2.2.7.1 Fan characteristics

The fan shall take suction from atmosphere. The fan characteristics shall be compatible with pulverized coal system resistance and boiler operation at rated loads, during boiler start up and low load operation with minimum number of mills. The system resistance curves shall always be sufficiently below the fan stall line. The best efficiency point of the fan shall be close to 100% TMCR operating point.

2.2.7.2 Fan control system

- i) The system shall be designed to achieve stable and satisfactory operation with air flow control and air pressure controls.
- ii) Fan flow control shall be by blade pitch control. The final control element shall be electrically/ pneumatically operated and shall not have a backlash or play etc.
- iii) The regulating dampers for air pressure control shall operate in the range of 20% to 85% steam generator loads up to BMCR conditions.
- iv) The system shall be capable of working on automatic mode for all regimes of operation in a steady and stable manner.

2.2.7.3 Constructional features

- i) Material of construction
 - a) Fan blades : High strength aluminum alloy with minimum hardness of BHN-75.
 - b) Base plate : Cast iron or welded steel.
 - c) Casing : Sheet steel of suitable thickness.
 - d) Fan inlet boxes, diffuser and intermediate pieces : Fabricated with sheet steel of thickness not less than 5 mm.
- ii) Special construction features:
 - a) The fan suction shall be provided with rigid bird and trash screen assembly and shall have suitable arrangement to prevent rain water from directly entering the fan.
 - b) The fan design shall be over hung type. The layout of PA fans shall ensure interchangeability of impellers. Similar fans shall have same direction of rotation.
 - c) The contractor shall submit detailed calculations for purchaser's approval to confirm compliance with the sizing requirements specified under clause 2.1.
 - d) Pulsation shall be avoided by suitable design of fan and connecting ductwork.



iii) Fan bearings:

- a) The rotor assembly shall be supported over a oil lubricated bearing assembly consisting of antifriction/sleeve bearing adequately sized to take care of radial thrust loads.
- b) Bearing housings shall be provided with vibration pad and sensors for remote monitoring, interlock and protection.
- c) In case of oil lubricated bearing, the design shall be such that bearing are lubricated by external force oil lubricating system in which oil is cooled by external cooler. In addition, sump lubrication shall also be provided.
- d) One number duplex RTD (100 ohm at 0⁰ C) and temperature indicators shall be provided for local and remote monitoring of the bearing metal temperature of fans for each bearing.

iv) Fan lubrication system

The lubricating system shall be complete in all respect, compact and frame mounted. The lube oil pressure shall be higher than cooling water pressure. Each bearing shall be provided with an oil level indicator and screwed drain plug.

- v) Silencers shall be provided to limit the noise level to the specified values.
- vi) Fan vibration monitoring pads shall be provided.
- vii) Fan housing shall be designed for ease of maintenance and access to the fan wheel or impeller. The casing shall be split type to provide easy removal of the fan wheel or impeller for replacement and repairs. Access doors shall be provided in each suction chambers, casing. The casing section shall have gasketed joints to ensure air-tight sealing. Drain connections shall be provided at the bottom most point of fan housing.
- viii) Fan casing shall be properly stiffened to minimize vibrations and distortions during operation.

2.2.7.4 Primary air flow measurement

- i) PA flow measuring devices shall be provided at air inlet to each mill for total air flow measurement and control.
- ii) Independent tapping points with necessary isolating valves shall be provided for control, measurement and performance test.
- iii) Location, type and design of flow measuring devices shall be subject to purchaser's approval.
- iv) Necessary temperature element points for temperature compensation in the flow measurement shall also be provided.



2.2.8 Balanced Draft System

2.2.8.1 Both FD and ID fans shall operate with highest possible efficiency which shall be nearly equal at the 100% TMCR and test block points.

2.2.8.2 Construction features

The construction of FD & ID fans shall comply with the following requirements:

Description	FD fans	ID fans	
	(Axial type)	(Radial type)	(Axial type)
i) Type of fan blade	Stream line, aerofoil shaped section	Backward curved single thickness plate bladed type or aerofoil type	Stream line, aerofoil shaped section
ii) Blade material and thickness	High strength Al-alloy BHN-75 (min)	25mm (min.) thick blade plate provided with renewable liners of wear resistant material having minimum 10 mm thickness.	High strength Al-alloy with anti wear spray coating/ liners.
iii) Fan speed	Maximum 1500 rpm	Maximum 600 rpm	Maximum 600 rpm
iv) Air/flue gas flow control	Blade pitch control	Variable frequency drive or hydraulic coupling	Blade pitch control
v) Fan critical speed	Not less than 125% of fan maximum operating speed	Not less than 125% of fan maximum operating speed	Not less than 125% of fan maximum operating speed
vi) Fan component design	To withstand torsional stresses three times the normal full load motor torque at all speeds	To withstand torsional stresses three times the normal full load motor torque at all speeds The shaft material shall be 15 Mo3 or better. The operating stresses shall be limited to 2kg/mm ² . Welded zones shall be suitably stress relieved and residual stress shall be considered for design.	To withstand torsional stresses three times the normal full load motor torque at all speeds The shaft material shall be 15 Mo3 or better. The operating stresses shall be limited to 2kg/mm ² . Welded zones shall be suitably stress relieved and residual stress shall be considered for design.
vii) Fan casing material and plate thickness	5 mm (min.)	Abrasion resistant high BHN Steel 8 mm (min.)/ 12mm (min.) mild steel with liner thickness 6 mm (min.).	Abrasion resistant high BHN Steel 8 mm (min.)/ 12mm (min.) mild steel with liner thickness 6 mm (min.).
viii) Fan housing design pressure	Shut off head of the fan	Shut off head of the fan	Shut off head of the fan



- Note : a) Fan components along with servo/blade pitch control mechanism shall be designed to withstand and continuously operate with the maximum air or flue gas temperature that these fans will be required to handle.
- b) ID fan components shall also be designed to withstand the excursions upto 300⁰C which may persist for about 30 minutes duration.

2.2.8.3 Fan bearings

- i) Bearing shall be provided with oil bath to avoid damage in case of complete loss of plant auxiliary power when the fans must coast down without power.
- ii) Oil reservoir in bearings housing shall be sized for maintaining lubrication for extended periods in case of oil circulation system being out of service.
- iii) One number duplex PE-RTD (100 ohm at 0⁰C) and temperature indicator shall be provided for each bearing.
- iv) Bearing housings shall be provided with vibration pads and sensors for remote monitoring and interlock/ protection.

2.2.8.4 Fan balancing

- i) The fans shall be statically and dynamically balanced before. Balancing of each fan shall be checked and adjusted at site, if necessary.
- ii) Natural frequency of fan components shall be established by vibration testing to ensure that no part of the wheel is adversely excited by any force generated at operating speeds.
- iii) For axial fan cantilever, variable pitch blade shall be subjected to natural frequency. The other components of ID & FD fan wheels need not be subjected to natural frequency test if supplier can prove that these component are very rigid and have very high natural frequency compared to the operating frequency of respective fans giving justification.

2.2.8.5 Operational requirements

FD & ID fans shall meet the following operational requirements:

Description	FD fans	ID fans
Mode of operation	a) Two fans in parallel b) One fan operation (one as well as both streams in operation)	a) Two fans in parallel. b) One fan operation (one as well as both streams in operation)
Fan control	a) Capable of operating in automatic mode for all regimes of operation in a steady and stable manner	a) Capable of operating in automatic mode for all regimes of operation in a steady and stable manner



	b) The final control element shall not have any backlash, plays etc., and shall operate in the range of 20% to 85% BMCR load.	b)The final control element shall operate in the range of 20 to 85% BMCR load.
Vibration monitoring	Suitable pads matching with vibration pickup shall be provided on fan bearing housings.	Same as that for FD fans
Bearing metal temperature monitoring	Shall be possible from remote as well as locally using adequate nos. of duplex platinum RTDs (100 ohms at 0°C.)	Shall be possible from remote as well as locally using adequate nos. of duplex platinum RTDs (100ohms at 0°C)

Note :- The fans shall be suitable for parallel operation and sharing the load equally over the entire range of operation without hunting. Pulsation shall be avoided by suitable design of fans and connected ductwork.

2.2.8.6 Flow measuring devices

- i) The draft plant shall include venturi/ aerofoil type flow elements in the air system for total air flow measurements and control, each with three pairs of tapping points.
- ii) Two nos. duplex temperature element with thermo wells for temperature compensation shall be provided.

2.2.8.7 Fan casing

- i) The fan casing shall be of split type to facilitate easy removal of the fan wheel or impeller for replacement and repairs.
- ii) Access doors shall be provided in each suction chamber casing and diffuser.
- iii) The sections shall have gasketed joint to ensure air tight sealing.

2.2.8.8 Fan layout

The layout of FD fans shall ensure interchangeability of the impellers. Similar fans shall have same direction of rotation.

2.2.8.9 Drain connections

Drain connections shall be provided at bottom most point of the fan housing.

2.2.8.10 Fan suction

- i) Silencers shall be provided at the suction of FD fans to limit the noise level to 85 dBA at a distance of 1.0 m.
- ii) Fan suction shall be provided with rigid bird and trash screen assembly and shall have suitable arrangement to avoid rain water from directly entering the FD fan.
- iii) Location of FD fan hood shall prevent entry of dusty air into fan.

2.2.9 Fuel Oil System

The fuel oil system shall comprise of fuel oil preparation and firing system for heavy fuel oil (HFO/LSHS/HPS) and LDO, fuel oil drain system and fuel oil condensate system.

i) Heavy fuel oil firing system

Heavy fuel oil shall be used for initial start-up, low load operation and as secondary fuel for pulverised coal flame stabilization at the start ups and low load operation. The scheme as envisaged for firing these oils shall cater to requirements of two units. The fuel oil shall be drawn from HFO storage tank(s) by fuel oil pressurising pumps and pumped through steam oil heaters. The oil shall be taken in steam generator unit(s) and re-circulated back to the storage tanks through oil coolers. The oil requirement of oil burners of the steam generator shall be tapped off from a ring main formed at the respective steam generator area. The oil pressure shall be maintained to the required value in the pressure main by means of automatic pressure regulating valve(s). Oil temperature shall be controlled by regulating steam flow to fuel oil heaters. All facilities required for functioning of fuel oil supply to the burners under certain operating conditions etc. shall be incorporated in the design. For each steam generator between pressure oil line and return oil line an interconnecting line shall be provided with automatic control system to maintain the pressure of the oil to the steam generator at a predetermined value.

ii) LDO firing system

The LDO firing system shall be provided to facilitate start of units when no auxiliary steam is available from external source. Light diesel oil firing system shall also be used for cold start up of steam generators and for flushing of heavy fuel oil lines. Basic scheme for light oil system shall be the same as that discussed above for heavy fuel oil system, except that the suction for the LDO pressuring pumps shall be from the LDO tanks and there shall not be any heating requirements. Provision of draining shall be provided in the LDO system.

iii) Fuel oil drain system

The fuel oil drains from different equipments and piping etc. of a steam generator shall be brought by gravity to the drain oil tank provided for each steam generator. The oil collected in these tanks shall be periodically pumped back to the fuel oil storage tanks (in purchaser's scope). Drains from the common oil pressurising pump house area shall be led to another drain oil tank and shall be pumped to fuel oil storage tanks by 2x100% pumps. Adequate heating arrangement shall be provided for drain oil tanks.

iv) Oily water drain system

The oily waste water drains from each steam generator area shall be collected and suitably treated in an oil separator. The treated out let water shall not have oil content more than 10 ppm. The recovered oil from oil separators shall be led to drain oil tanks/ waste oil collection tanks. Separated water shall be pumped to effluent treatment plant (in purchaser's scope) using sump pumps.



v) Fuel oil condensate system

Condensate from complete fuel oil plant shall be brought to a common condensate flash tank in fuel oil unloading area. Drains from this condensate tank shall be connected to station drains.

2.2.9.1 Fuel oil preparation and firing system

- i) The fuel oil preparation and firing system shall be designed common for both the units. The system shall be designed to function in total association with the furnace safeguard supervisory system (FSSS).
- ii) The heavy fuel oil system shall have the following design features:
 - a) Steam tracing shall be provided for all the heavy fuel oil lines. There shall be no cooled legs in oil supply and recirculation piping.
 - b) Relief valves shall be provided on larger section of fuel oil pipes which can be isolated.
 - c) Isolation valves shall be provided both on up stream and down stream sides for all in-line items like pumps, heaters, flow meters, filters, control valves etc. which are required to be taken out for maintenance.
 - d) Adequately sized pressure accumulators shall be provided on fuel oil lines to individual steam generator for maintaining constant oil pressure. Each accumulator shall be complete with a pressure gauge, stop cock and isolation valves to ensure maintainability of nitrogen pressure.
 - e) Facility shall be provided for complete flushing of heavy fuel oil handling system by LDO. For LDO handling system, steam flushing system shall be provided for cleaning during commissioning.
- iii) Design and sizing of various pumps shall be based on following criteria:

	Heavy oil pressuring pumps	LDO pumps	Drain oil pumps	Sump pumps
a) Type of fuel to be handled	HFO/HPS/LSHS	LDO	HFO/HPS/LSHS/LDO	Oil and water
b) Temperature of fuel oil to be handled	90 ⁰ C	Atmospheric	90 ⁰ C	50-85 ⁰ C
c) Pump design and construction	-----HI Standards, ASTM, ASME or equivalent code) ----- (subject to purchaser's approval)			
d) No. of pumps	3 (2W+1S)	3 (2W+1S)	2 (1W+1S) per unit	2 (1W+1S) per unit
e) No. of oil heaters	3 (2W+1S)	Nil	-	-



Section- 2 (Steam Generator and Auxiliaries)

f) Capacity of each pump	To cater to 30% BMCR requirements of one steam generator without coal firing plus 10%.	To cater to minimum 7.5% BMCR requirement of one steam generator without any coal firing plus 10%.	4m ³ /hr	7.5m ³ /hr
g) Pump suction head	Head from tank	Head from tank	(-)1.0 m approx.	Flooded suction
h) Pump discharge head.	To suit the requirements of burners	To suit the requirements of burners	As required to pump oil from drain oil tanks to main oil storage tanks	To suit site requirements
iv) Construction of heavy fuel oil pressuring pumps, LDO pressuring pumps and drain oil pumps shall comply with the following:				
a)	Type of Pump	: Rotary, positive displacement, horizontal pump fitted with relief valves.		
b)	Pump/motor base plate	: Common		
c)	Type of drive	: Constant speed squirrel cage, induction motor with flexible couplings.		
d)	Materials			
	• Casing	: Close grained cast iron		
	• Shaft	: Carbon steel		
e)	Type of bearings	: Antifriction		
v) Heavy fuel oil heaters shall be designed based on the following:				
a)	Type and no. of heaters	: Three (2 working + 1 standby) shell and tube type, preferably with oil through tubes. (oil through shell also acceptable).		
b)	Capacity of each heater	: To suit the rated capacity of each heavy fuel oil pressurising pump.		
c)	Heater inlet fuel oil temp. (considered for sizing)	: 30 ⁰ C		
d)	Heater outlet temperature	: To suit the viscosity requirements at the fuel oil tips for the grade of oil (HPS/HFO/LSHS) used.		
e)	Metal temperature of heater heat transfer surface	: 210 ⁰ C (Maximum)		



- f) Heater design and construction : TEMA, ASME Boiler and pressure vessel code, HEI standards, USA. Pipe connections to heater as per TEMA class C BEV type.
- g) Heater tubes : Seamless (tube bundles shall be of removable type)
- vi) Filters
- a) Coarse filter shall be provided at pressuring pumps inlet and fine filter at oil heater outlet.
- b) The maximum pressure drop across filters shall be 0.1 kg/cm² when filter is clean and 0.3 kg/cm² when filter is 50% clogged.
- c) Material of filtering mesh shall be stainless steel.
- d) Aperture size for fine filter shall not exceed 150 μm or shall be at least 30% smaller than smallest oil orifice or passage to the burners.
- vii) Trip and nozzle valves
- a) Heavy fuel oil and light oil trip valves and nozzle valves shall be suitable to handle oils at temperature and pressure required at the burners. Further, these valves shall confirm to ANSI leakage Class-VI under shut off pressure conditions of respective pumps.
- b) The solenoids of trip valves and individual burner nozzle valve shall be of single coil heavy duty construction having class 'H' insulation.
- c) The closing time of trip and nozzle valve shall be less than one (1) second. The valves shall close when de-energised /failure of air supply.
- d) The operating voltage shall be as under:
- Trip valve solenoid : 24 volts DC
 - Nozzle valves solenoid : 110 volts AC
- viii) Oil burners and burner components

Description	Heavy fuel oil firing system	LDO firing system
a) Type of burner	Steam atomised (steam to be tapped off from auxiliary steam system)	Air atomised (air tapped off from the compressed air system)
b) Burner cooling	Steam or air	Air



c) Burner tip material	Resistant to corrosion (Tips to be fully leak tight) due to oil containing sodium, vanadium, sulphur, chloride etc.	Resistant to corrosion due to fuel oils containing sodium, vanadium sulphur, chloride etc.
d) Minimum guaranteed life of burner tips, before needing any maintenance/replacements.	----- 8000 hours -----	
e) Hardness of atomiser (hardness to be retained even at 400 ⁰ C)	Minimum vickers hardness number of 400	Minimum vickers hardness number of 400
f) Type of oil ignitor	High energy arc ignitors	High energy arc ignitors

ix) Piping shall conform to following codes:

Piping	Code
a) Steam and condensate piping below 20 kg/cm ² pressure	IS: 1239 (heavy duty) or ASTM 106 Gr. B or approved equivalent.
b) Fuel oil piping	: API-5L Gr. B or ASTM-106 Gr. B in the unloading area. : IS:1978 or approved equivalent from discharge of pressurising pump to the boiler.

Piping, fittings shall be of carbon steel butt welded connection conforming to ASTM A-234 or approved equivalent. All flanges, where provided, shall conform to IS :6392 or approved equivalent.

x) Valves shall conform to following:

Parameter	Requirement
a) Type of valves (for oil services)	Plug type, leak proof, self lubricating
b) Material of valves on oil lines: <ul style="list-style-type: none"> • On pump suction side • On pump discharge side 	Cast iron Cast steel
c) Material of valves on steam and condensate lines	Cast steel

Instrument root valves on heavy oil lines shall be of 25 NB size, flanged OS and Y type with body rating in ASA as per process conditions.



- xi) Maintenance facilities to be provided shall include:
- a) Burner maintenance trolley along with accessories
 - b) Fixed drip tray for each oil burner to contain any oil leakage
 - c) Handling facility (with runway beam, hoist, equivalent structure etc.) for all pumps and heaters.
 - d) Oil gun cleaning station and the facility for blow off of the oil guns using auxiliary steam at each firing floor. For this purpose auxiliary steam tapping with necessary isolation valves and necessary hose connection shall be provided.
- xii) Operational requirements:
- a) Facilities shall be provided for auto start of standby heavy fuel oil/LDO pressuring pumps in event of tripping of any running pump or low fuel oil pressure. For drain oil pumps, auto start and shutdown facility shall be provided in conjunction with level in the drain oil tanks.
 - b) Interlock shall be provided for automatic purge before light up and after failure to first oil burner operation.
 - c) Separate flame viewing opening/ facility shall be provided for boiler operation and for flame monitoring at each burner from out side. The provision shall be made to keep the system cool below 75⁰C and to keep the optical system clean during firing/non firing by pressurised air.
 - d) Adequate instrumentation such as temperature, pressure, differential pressure, flow transmitters, switches for independent high and low signalling contacts required for burner management system and other interlock/alarm shall be provided for interfacing with other systems/ equipments.
 - e) Adequate potential free contacts shall be provided for status of individual pumps.

2.2.9.2 Fuel oil drain and condensate system

- i) Design and construction of drain oil tank(s) and condensate tank shall comply with following requirements:

	Drain oil tank	Condensate flash tank
a) Medium to be stored	Heavy fuel oil (HPSLSHS/HFO) and LDO	Condensate water/ flash steam



Section- 2 (Steam Generator and Auxiliaries)

b)	No. of tanks	Two (2) in boiler area and one (1) in FO pressurizing pump house area.	One (1)
c)	Tank capacity	6m ³ (each) in SG area and 10m ³ in FO pressurizing pump house area.	6m ³
d)	Design and construction code	IS:800	IS: 2825 Class-II or equivalent
e)	Design temperature	120 ⁰ C (minimum)	215 ⁰ C (minimum)
f)	Tank design pressure	-	As per applicable code
g)	Type of construction	Rectangular	Vertical cylindrical with dished ends
h)	Material of construction	As per IS:2062	As per IS:2825/ ASME Sec. VIII
i)	Corrosion allowance	1.8 mm	1.8 mm
j)	Insulation	Required	Required
k)	Nominal venting capacity	-	Vent pipe of 250 Nb (min.) and 3.5 m height
l)	Heater tube material	50 Nb tubes as per IS1239 (heavy grade) or ASTM 106 Gr. B	-
ii)	The design, fabrication, erection, commissioning and testing of the tanks shall be conform to IS:2825.		
iii)	Steam coil heaters shall be provided at the bottom of drain oil tanks to maintain the oil temperature to facilitates its pumping. The heaters shall be sized considering ambient air temperature of 10 ⁰ C. Total heating surface of heaters shall not be less than 4 m ² per drain oil tank. Steam for the heaters shall be drawn from the auxiliary steam supply system.		

2.2.9.3 Fuel oil cooler

Oil cooler on the heavy fuel oil return line shall be sized for cooling the return oil from each unit to the temperature of oil in the fuel oil storage tanks.



2.2.10 Duct Work and Dampers

2.2.10.1 Duct work

- i) Loads for design of ducts and structures:

The duct design shall take into account following loads all occurring together:

- a) Wind load as specified.
- b) Dead weight including weight of insulation, lining, wash water and vertical live load.
- c) Horizontal flue gas ducts shall be designed additionally for minimum 245 kg/m^2 fly ash loading on the surface or for one fourth of duct full of ash or for maximum possible accumulation of ash in the duct work, under all normal, upset or abnormal operating conditions, whichever is higher. The ash density for the purpose of loading shall be at least 1300 kg/m^3 .
- d) Expansion joint reaction.
- e) The following minimum load factors shall be applied to the design loads:

Temp. ($^{\circ}\text{C}$)	:	27	38	93	149	203	260	316	321
Load factor	:	1.00	1.02	1.12	1.19	1.25	1.29	1.34	1.42
- f) The duct work and its structure shall take into account loads due to future addition of FGD interconnection ducts and dampers in the duct between ID fan outlet and chimney inlet.

- ii) Duct slope:

All interconnecting gas ducts, connecting one gas stream to another, between the boiler and the ESP shall have a minimum slope of 45 deg. with respect to horizontal so that any chance of accumulation of ash particles in the duct can be avoided under all operating conditions.

- iii) Type of duct construction:

The ducts shall be of rectangular cross-section and shall be of all welded construction. Circular ducts shall not be acceptable. The following requirements shall be satisfied:

- a) Duct stiffening shall be made of rolled sections.
- b) The thickness of the duct plate shall be suitably increased, if required, in the transition zone at steam generator outlet where the flue gases change direction, to increase the wear life of the duct plates.



- iv) Material of construction:
- a) Duct plates, turning vanes : ASTMA 36 or equivalent
perforated plates
 - b) Structural shapes : ASTMA 36 or equivalent
 - c) Pipe struts, trusses tracing : ASTMA 53 or equivalent
 - d) Erection bolts for ducts : ASTM A 307 or equivalent
 - e) Bolts for connection to : ASTM A 325, AISIA 325
structural steel (friction type) or equivalent
 - f) Stainless steel : ASTM A 316 L
 - g) Gaskets : 'Refrasil' by Hitco or equivalent
 - h) Access and inspection doors : Reinforced steel plate
- v) Insulation and lagging:
- a) All air ducts handling air above ambient temperature shall be suitably insulated and lagged to suit the design requirements.
 - b) Thermal insulation shall be applied to all air/gas ducts to meet the specification requirements.
 - c) Acoustic insulation shall be used on air and gas ducts to restrict the noise level to 85 dB(A).
- vi) Specific requirements:
- a) The stiffeners provided on the ducts wall shall be of such a design and layout that no rain water can accumulate on the duct surfaces.
 - b) The flanges at the bolted joints shall have adequate stiffeners to avoid damages to the flanges.
 - c) All necessary wall boxes and floor collars shall be provided where the duct work pass through walls, floor and roof.
 - d) The floor collars shall be fitted with a high combing to prevent water and dust falling through the hole.
 - e) The duct work shall be fitted with a steel hood to cover the opening.
 - f) Weather proof flashing shall also be provided wherever necessary.
 - g) The configuration and design of ducts shall be coordinated with the pulveriser parts removal requirement.



- h) Air and gas ducts shall not counter internal bracings which cause excessive pressure drop.
 - i) Duct plates shall be designed for one-way beam action over stiffeners and considered fully continuous over all supports.
 - j) The deflection of the plate, assumed continuous, shall be less than one-half the plate thickness.
- vii) Duct work structure:
- a) Duct work sections between expansion joints shall be checked and designed with regard to their ability to transmit loads to supports. Care shall be exercised to identify uplift condition.
 - b) Internal stiffening elements shall consist of trusses, preferably comprised of extra-strong steel pipes (minimum diameter 76.2 mm) acting in conjunction with external stiffeners. Such internal stiffeners for the flue gas duct between boiler and ESP shall be provided with erosion protection shields. The number of internal trusses shall be limited to the minimum required for structural integrity and shaped so as to offer least resistance to gas flow and to minimise the accumulation of fly ash in the bottom of duct.
 - c) Corner angles shall be used on inside corners of all ducts to provide adequate continuity.
 - d) Inside welds of corner angles to duct plate shall be continuous and seal welded. Where inside surface of ducts will be coated, welds shall be full throat.
 - e) Field welding and all connection of bracing (stiffening elements) to stiffeners shall be well designed in order to develop full strength of the members. The gusset plates shall be of minimum 10 mm thickness.
 - f) The duct, plates, trusses, stiffeners and ductwork shall be designed as structures in accordance with relevant Indian Standards.
 - g) All opening inducts shall be reinforced for all design loads.
 - h) Ductwork supports may be hangers or sliding bearing, guides and anchorages. The allowable bearing stress for self-lubricated plates shall be 70 kg/cm².
- viii) Fabrication requirements:
- a) Fabrication shall be as per IS codes for design, fabrication and erection of structural steel for building.
 - b) Welding shall be in accordance with Section IX of ASME/ equivalent code.
 - c) Ducts shall be strength welded and seal welded to produce a gas tight duct. Alignment holes shall be provided in mating flange sections.
 - d) Ducting shall be detailed and fabricated in the pieces as practical taking into account shipping and erection considerations.



- ix) The horizontal flat surface of air and gas ducts shall be pitched for drainage. Where necessary, stiffeners shall be arranged to avoid formation of pockets.
- x) Access and inspection doors of hinged type with matching heavy duty surface shall be provided. The access and inspection door shall be minimum of 500 mm x 500 mm size. The door closing devices shall be designed to force the doors to make an air or gas tight sealing when closed.

2.2.10.2 Expansion joints

- i) The expansion joints shall be of metallic type suitable for the service conditions.
- ii) Expansion joint shall not support the duct work.
- iii) The materials for joints shall be tested as per IS/ASTM/DIN or other international standards.
- iv) The outer cover shall preferably be elastomer coated for better corrosion and abrasion resistance and weatherability.
- v) The minimum trouble free operational life of expansion joint shall not be less than 20000 hrs of operation from the date of commissioning.

2.2.10.3 Blanking plates

Bolted plates or other positive closure means shall be provided in order to permit pressure testing of steam generator enclosure.

2.2.10.4 Dampers

- i) Power operated gas tight isolation dampers along with their drives shall be provided at all locations required for carrying out internal repair and maintenance of pulverisers, electrostatic precipitators, ID fans, PA fans, FD fans when the steam generator is under operation. Interconnecting dampers shall be provided where necessary. As a minimum, the following locations shall be provided with power operated gas tight dampers:
 - a) On each hot air duct to each of the mills.
 - b) On each inlet and outlet to each ESP stream (there being four ESP streams, with eight inlets and eight outlets).
 - c) Before and after each ID fan.
 - d) At inlet to each of the regenerative air pre heater on flue gas side.
 - e) Before and after each of the regenerative air pre heater on air side.
 - f) At discharge of each of PA fan.
 - g) At discharge of each of FD fan.



- h) Interconnecting duct dampers as necessary.
- ii) Heavy duty multi louver dampers shall be provided at locations not requiring tight shut off duty.
- iii) Pneumatically or motor operated control dampers shall be provided on the hot and cold primary air inlet to each mill, and at each air pre heater outlet on flue gas path (if applicable).
- iv) Type of power operated gas tight dampers at various locations shall be as follows:
- a) Guillotine gate type : at locations (i) a), b), c), d) and f) above.
- b) Diverter type : at location (i) d) above, if required due to space constraints.
- c) Multi louver type : at location (i) e), g) and h) above.
- v) Damper gas tightness:
- The dampers at mentioned clause (iv) a), b) above shall have a guaranteed gas tightness efficiency (on flow) of not less than 99.3% along the duct as well as from the duct to atmosphere or from atmosphere to duct depending on the pressure in both the damper open and damper closed condition without the use of seal air fans of the damper and 100% with the use of sealing air.
- vi) Pressurisation fans:
- a) All dampers at ID fan discharge, primary and secondary air at APH outlets and mill inlets shall be provided with 2x100% pressurisation fans to achieve 100% sealing efficiency. Alternatively, for mill inlet gate, bidder may take seal air from PA fan cold air bus.
- b) The location and scheme for pressurisation system shall be to purchaser's approval.
- vii) All dampers shall be designed to withstand the operating air and flue gas temperature without distortion.
- viii) The multi louver damper shall be capable of effectively stopping the flow when in closed position and while in full open position shall cause minimum pressure drop. The isolating damper design shall provide positive shutoff when closed.
- ix) All regulation dampers, vanes, blade pitch controls coming under auto regulation shall be able to provide the desired relationship between percentage opening and the flow.
- x) The auto regulating dampers shall be capable of being operated between 20% to 85% opening as per the optimal requirements of control systems to achieve stable, steady and smooth automatic control of the plant and processes under all operating conditions.



- xi) There shall not be any backlash, play etc. with linkage mechanism, actuator and final control element.
- xii) Thermal expansion of ducting shall not produce stress in louvers, linkage arrangement etc.
- xiii) Outlet dampers of seal air fans, scanner air fans and emergency dampers of scanner air shall be pneumatically operated, suitable for remote manual operation.
- xiv) All pneumatically operated interlocked dampers actuators shall be provided with solenoid valves.
- xv) Guillotine dampers:

All guillotine dampers shall be located in horizontal duct to avoid fly ash build up when in closed position and shall be of top entry type. The damper sealing efficiency shall be minimum 99.3% on flow without seal air and it shall be 100% with seal air.
- xvi) Multi louver dampers:
 - a) The damper shall be of heavy duty construction and shall operate without bind or fluttering under operating conditions.
 - b) The damper louver shaft shall be rigidly constructed to prevent bending and shall be suitably insulated to protect from over heating.
 - c) The spindles shall be adequately sized and bearings suitably insulated to protect over heating.
 - d) The shaft bearings shall be mounted outside the damper box channel and arranged for convenient inspection.
 - e) Stuffing boxes shall be provided on all damper blade shafts.
 - f) The shaft shall be horizontal wherever possible.
 - g) For preventing hot air or gases from escaping around damper shaft, double gland type stuffing boxes with graphite impregnated packing material shall be provided on all damper blade shafts.
 - h) The dampers in flue gas paths shall be so located that the build up of grit behind the damper blades is reduced to a minimum.
 - i) The damper sealing efficiency shall be minimum 99.30% on flow without seal air and it shall be 100% with seal air.
- xvii) Diverter dampers/ flap dampers (if provided)
 - a) Dampers shall be single flap/double flap construction with flexible duplex seals mounted on the flap itself. The seals shall have minimum life of 3 years. The seal material shall be high nickel alloy equivalent or better than hastelloy C-276 (ASTM B575, UNS 10276) or Inconel 625.



- b) The diverter damper shall ensure sealing efficiency of minimum 99.3% on flue gas flow without seal air. To provide man safe isolation for on-line maintenance of air pre heater, 2x100% seal air fans per damper shall also be provided to attain 100% gas tightness.
 - c) The diverter flap shall be totally out of flue gas flow path in order to avoid any erosion from ash.
 - d) The damper design shall prevent ash accumulation when in closed position.
- xviii) Weather hood to prevent rain water entry and accumulation shall be provided at damper top.
- xix) If grease lubrication is required, grease connection shall be accessible and suitable platforms etc. shall be provided.
- xx) Dampers operation:
- a) All dampers shall be arranged to facilitate local manual operation also from a gallery or floor level. Open and closed positions shall be clearly marked on the dampers
 - b) The force required to operate the damper shall be limited to 35 kgs (maximum) at the rim of the hand wheel.
 - c) The operating gear shall be fitted with a graduated indicator and shall be designed such that the damper may be retained in any position. The isolating dampers shall additionally be fitted with locking devices to permit locking in the fully open and shut positions.
 - d) All powered dampers shall also have provision for manual operation during emergency and maintenance along with graduated local position indicator.
 - e) Suitable all-around approach and platform shall be provided for manual operation of dampers and for carrying out maintenance on damper.
 - f) All bearings for spindles for damper operating gear shall, be arranged for efficient grease lubrication. Grease lines of copper/ steel shall run from all greasing points on each damper to a convenient and easily accessible location adjacent to the respective damper and terminated with suitable clamps and grease nipples on a steel frame to facilitate easy lubrication.



2.2.11 Steam Generator Integral Piping, Valves, Fittings and Mountings

- 2.2.11.1 In addition to specific requirements indicated in the subsequent paragraphs below, the steam generator integral piping, valves, fittings and mounting shall also comply with all specification requirements of power cycle piping given in Section- 4 of this specification.
- 2.2.11.2 All the start- up vents shall be provided with two valves in series one motorized isolating and one motorized regulating type (low noise, erosion resistant type). Silencers shall be provided on all start up vents and lowest set pressure safety valves.
- 2.2.11.3 Temperature indicators shall be provided on all drain lines including soot blower drain line.
- 2.2.11.4 Air release valves, two in series, shall be remote motor operated and shall be connected to a funnel with drain leading to drain trench.
- 2.2.11.5 Complete valve schedule including control valve sizing calculations, characteristics, and data sheets etc. shall be furnished and shall be subject to purchaser's approval.
- 2.2.11.6 Drain valves (two in series, one manually operated isolation and other motorised regulating) shall be provided for draining furnace walls, superheaters, reheaters, economiser and feed water lines. The arrangement of drain system shall comply with following requirements :
- i) Drain lines upto drain valves and drain valves shall be designed for the maximum operating parameters of main process line to which it is connected
 - ii) Drain system shall be sized to enable draining of complete pressure parts in maximum one (1) hour.
 - iii) The drain valves shall be of low noise and erosion resistant type. The limiting noise level for regulating drain valves shall be 90 dBA.
 - iv) The flow velocity through the drain valves shall not exceed 90 m/s.
 - v) Plugging/ locking arrangement with chain and lock system shall be provided for each isolating valve.
- 2.2.11.7 Blowdown valves, two in series, shall be provided at the lowest point of each water wall header comprising of one manually operated isolation valve and one motorized regulating valve. Valves shall have plugging/ locking keys and shall be located at appropriate location for convenient operation. The piping from this blowdown valve shall be connected to blow down tank. .
- 2.2.11.8 All remote operated control valves shall be provided with the following:
- i) 100% bypass control valves, remote operated and exactly identical to main control valve.
 - ii) Separate power operated isolation valve on upstream side of each of main and bypass control valve.
 - iii) Separate manually isolation valve on down stream side of each of main and bypass control valve.



- iv) Pressure gauge at inlet and outlet of each respective control station in the common line of main and bypass control valve.
- 2.2.11.9 Drains from headers, gauge glasses and integral piping of steam generator shall be terminated into one or more drain collection headers which in turn will be connected to blow down tank. The steam from the blow down tank shall be vented out to the atmosphere and the drain shall be connected to the plant drain system after the same has been cooled by the cooling water. Selection of design conditions of blow down tank shall be as per BS:806 and the atmospheric vent pipe shall be extended upto SG top canopy level. Necessary cooling system for this shall also be furnished. Suitable arrangements to prevent overflow in this tank shall be furnished. The valves in the blow down line shall be power operated and regulating type with provision of a motorized isolating valve on upstream side and manual isolating valve on downstream side. The water level control station shall be complete with the control valves, bypass valves, and the level controllers.
- 2.2.11.10 Boiler fill line shall be provided with a non-return valve of size not less than 100 Nb and a stop valve.
- 2.2.11.11 All required sampling points shall be provided alongwith root valves including that for feed water at economiser inlet, saturated steam, superheated steam reheated steam.. The sampling probes shall be provided as per relevant section of the latest ASME power test code. For laboratory samples, necessary sample coolers with valves and cooling water pipe shall be provided. The root valves shall be of stainless steel. The cooling water shall be taken from the main cooling water system. Drain from sample coolers shall be terminated at appropriate floor level. Each steam and water terminal connection for vent, drain, instrument tapping point and sampling shall be provided with two valves.
- 2.2.11.12 Tapping points shall be provided for all the instrumentation and controls as required for performance guarantee tests.
- 2.2.11.13 All the valves (including drain, vent and air release valves) required to be operated during startup and shut down of steam generator shall be provided with remote motorized operation. For valves located in inaccessible locations, remote operation facility shall be provided to enable startup, shutdown, load monitoring from unit control room.
- 2.2.11.14 The number, size, location and setting of safety valves on drum, superheaters and reheaters shall be as per IBR. The safety valves shall be provided on all steam lines including soot blowing lines, auxiliary PRDS lines and the steam lines, wherever pressurisation may take place.

The safety valves and relief valves shall have minimum discharge capacities as under

- i) Safety valves on boiler drum and superheater (excluding power operated impulse safety valve) : Combined capacity 100% BMCR
- ii) Power operated impulse safety valves
- a) Superheater outlet : 20% BMCR
- b) Reheater outlet : 20% of reheater flow at BMCR

The noise level during lifting of safety valves of drum, superheaters and reheaters shall not exceed 105 dBA with the provision of silencer on the lowest set pressure safety valve.



2.2.12 Soot Blowing System

2.2.12.1 The type of soot blowers to be provided for different sections of the boiler shall be as below:

- i) For furnace chamber : Short rotary, single nozzle, retractable type.
- ii) Vertical pendent section : Two nozzles in diametrically opposite side, long retractable type.
- iii) For horizontal heat exchanger sections (rear pass) : Long rotary, multiple nozzle retractable type.
- iv) Air pre- heaters : Power driven swinging arm soot blower, or retractable multi-nozzle soot blower.

DDCMIS controlled soot blower control system shall be provided for sequential operation of soot blowers, soot blower steam pressure control and drain temperature control etc.

2.2.12.2 The design of air pre- heater soot blowing system including piping, valve and fittings shall allow use of high temperature steam from high temperature auxiliary steam header during start-up. A check valve and/or motor operated valve shall be provided on this high temperature line to prevent normal soot blowing steam from entering auxiliary steam header.

Safety valve of adequate capacity and setting pressure shall be provided on the soot blowing lines. The location of elements, travel and nozzle angles shall be such that maximum cleaning is obtained with a minimum of flowing medium.

The soot blowing system design shall be of self draining type.

2.2.12.3 Soot blowing system elements shall be manufactured from extra heavy seamless tubing of high temperature alloy steel. Heat, corrosion and erosion protection shall be provided for parts in permanent contact with hot gases.

2.2.12.4 Soot blower nozzles shall be single or multiple row of nozzles welded to prevent falling out during service. Venturi or straight bore nozzle shall be installed as per system requirement.

2.2.12.5 Retractable soot blowers (RSB):

- i) RSBs shall be retractable even during emergencies such as drop in steam supply pressure and low steam flow etc.
- ii) Long RSBs shall be half of steam generator width on each side.
- iii) Double helix cleaning pattern shall be used.
- iv) RSBs shall be actuated by electric motors
- v) RSBs shall be controlled from soot blower panel and shall be actuated by electric motors. Dual electric drive shall be provided.



- 2.2.12.6 Motor Control Centre (MCC) of soot blowers shall be draw out type, multi-tier, compartmentalised, double front type suitable for top/bottom entry of cable and shall be subject to approval of the purchaser. As an alternative, integral valve actuator with built in starter can also be offered.
- 2.2.12.7 The soot blowing control system shall be capable of following functions:
- i) Individual operation of any soot blower.
 - ii) Facility to bypass any soot blower.
 - iii) Automatic starting of each soot blower.
 - iv) Cancellation of operation of any soot blower in the system when required.
 - v) Monitoring all the essential requirements and display of operation of each soot blowing system.
 - vi) Trip selected soot blower operation, in case of malfunctioning or upset condition.
 - vii) Simultaneous operation of two soot blowers located on opposite walls.
 - viii) Manual over riding of automatic operation.
- 2.2.12.8 Warming- up of complete piping system before the start-up of soot blowing operation shall be facilitated by providing adequate number of pneumatic drain temperature control valves. Each pneumatic flow control valve shall have bypass line with adequately sized orifice plate for draining the system when the valve is closed. Temperature detectors shall be provided on the drain lines to ensure satisfactory warming- up and initiation of blowing operation.
- 2.2.12.9 All soot blowers shall be suitable for local and remote automatic sequential operation. Emergency hand crank shall be provided for each.
- 2.2.12.10 Provision shall be made to maintain the soot blower heads free of deposits during the periods when they are retracted and are not in operation.
- 2.2.12.11 The soot blowers shall be accessible from local operation platform and platforms/galleries etc. shall be provided at and around the soot blowers to facilitate maintenance and inspection.



2.2.13 Blow Down Tanks (BDTs)

2.2.13.1 Two number blow down tanks shall be provided for each steam generator, one intermittent blow down (IBD) tank and other continuous blow down (CBD) tank. The IBD shall be sized to receive the following:

- i) All blow down and drains from steam generator.
- ii) Drain from water wall headers, attemperators headers and CBD tank.
- iii) Alternate drains from main steam lines, CRH lines, HRH lines and SCAPH drains.
- iv) Other drains from power cycle piping.

The CBD tank shall receive the continuous blow down from the steam generator drum. CBD system shall be designed for maximum blow down of 5% BMCR load. Facility for complete bypass of CBD tank shall also be provided.

2.2.13.2 The IBD tank shall be located at ground level near steam generator and CBD tank shall be located at deaerator floor.

2.2.13.3 Tank design shall not allow discharge of any free water from vent. Water drops leaving vent pipe shall have sizes not more than 0.127 mm. The steam velocity through the vent pipe shall not exceed 90 m/s. Vent pipe size shall be so selected that no pressurisation takes place in the blow down tank.

The flashed vapour from CBD vessel shall be led to the deaerator.

2.2.13.4 Constructional features:

- i) Tanks shall be designed and fabricated as per requirements of IS 2825/ BS 806.
- ii) All drain connection to the tanks shall be tangential, and wear plates shall be provide to prevent erosion due to high pressure and high velocity drains.
- iii) Matching flanges shall be provided for level switches and other instruments.
- iv) Drain valves and drain piping shall be provided at the bottom of the BDT. All drains from BDT shall be cooled to a temperature not exceeding 60⁰ C.
- v) Manholes on BDT shall be provided with hung on hinged type bolted doors.



2.2.14 Auxiliary Steam Pressure Reducing and Desuperheating Stations (PRDS)

2.2.14.1 General

To meet the continuous and startup auxiliary steam requirements, two numbers auxiliary pressure reducing and desuperheating stations (PRDS), one taking tap off from main steam line (high capacity PRDS) and other taking tap off from cold reheat line (low capacity PRDS) shall be provided per unit. A high temperature unit header with steam parameters as 16 kg/cm² (abs) and 310⁰C shall be provided and shall draw steam from above two PRDS stations. A low temperature unit header with steam parameters as 16 kg/cm² (abs) and 210⁰C shall also be provided and shall draw the steam from high temperature unit header through a desuperheater. The auxiliary steam systems of the two units shall be interconnected. A branch connection alongwith isolating valve(s) and a blanking flange(s) shall also provided for interconnection with the future units on both high and low temperature headers.

If steam for the steam generator unit auxiliaries is required at pressure/ temperature other than that of the auxiliary steam headers, suitable arrangements shall be made by the Contractor in design of the steam generator to meet such requirements.

2.2.14.2 High capacity PRDS shall supply steam for following :

- i) Startup requirement of the unit
- ii) Continuous and intermittent requirement of the unit.
- iii) Startup requirement of other unit.
- iv) As standby to low capacity PRDS station.

2.2.14.3 Low capacity PRDS shall supply steam for normal requirements of its own unit.

2.2.14.4 The sizing of high capacity and low capacity PRDS shall be subject to purchaser's approval. Stub connections alongwith isolating valves shall be provided on low temperature header to meet the auxiliary steam requirement of other systems which are not in contractor's scope such as fuel oil system. Further, adequate number of spare connections shall also be provided on each header for purchaser's use.

2.2.14.5 Sharing of load requirement between high temperature header to low temperature header shall be done in case low capacity PRDS is unable to meet auxiliary steam requirement on its own.

2.2.14.6 Low capacity PRDS shall be capable of supplying continuous requirement of auxiliary steam to the unit. The change over of control from high capacity PRDS to low capacity PRDS and vice versa shall be automatic with manual override facility.

2.2.14.7 In case each unit is provided with only high temperature auxiliary steam header as per manufacturer's standard and proven practice, auxiliary steam requirement at lower parameters shall be met with PRDS stations provided for individual application. Further, connections with individual PRDS shall also be provided to meet the auxiliary steam requirement of other systems which are not in contractor's scope such as fuel oil system.



2.2.15 Walk Ways, Platforms and Stairs etc.

2.2.15.1 Walkways, platforms and staircases shall be provided in accordance with following clear width requirements:

- | | |
|---|-----------|
| i) Operating platforms and maintenance access walk ways | : 1500 mm |
| ii) Other walk ways | : 1000 mm |
| iii) Ladders and staircase | : 850 mm |

2.2.15.2 Platforms with necessary access shall be provided at all burner levels and all around the furnace to facilitate operation, service and maintenance of all burners and associated auxiliaries. The platforms shall generally extend upto 3 m from furnace walls. However where there are layout constraints, it shall be minimum 2.7 m.

Platforms shall allow complete burner withdrawal. The platforms at each burner elevation shall be continuous and run at same level without any interruption from intervening steps and obstructions etc. Adequate space shall be provided for placing local instrument enclosure/ racks and for performing maintenance work including enough space for door opening.

The burner platforms within 200 mm of igniter shall be welded steel chequered plate with edges welded-in place to prevent oil spillage from spreading.

2.2.15.3 Personnel access requirements:

Personnel access shall be provided for Class I, Class II and Class III areas as per following:

i) Class I area:

These are regularly attended access areas such as operating platforms which are fully accessible from an elevator landing. No ladders etc. shall be used for the access to these areas.

- Burner platforms shall have direct access to elevator unless levels are so close together that the 3500 mm minimum elevator door spacing does not permit separate elevator opening at each level. In such case, access stairs shall be provided for each burner level.
- Boiler drum shall be provided direct access from elevator without use of stairs.
- Observation ports, lancing openings, lubricated equipment, bearings, soot blowers, instruments, valves actuators and equipment requiring access during operation and for normal day-to-day inspection and maintenance shall have adequate platforms for access.
- Ash hoppers requiring fly ash removal by the ash handling system shall have adequate platforms for access to fly ash intakes.
- Boiler scaffolding inspection door shall be accessible from elevator landing.



ii) Class II area:

These are maintenance access areas such as furnace access doors, superheater and reheater access doors, safety valves actuators, and other areas requiring access only monthly or annually. These shall have access platforms of adequate size to permit two people to work (approximately 1.5 m²) with access ladders and maintenance access walkways for reaching the platforms. Access shall be provided on both sides of safety valves.

iii) Class III area

These are maintenance access areas where access is only required for painting, re-insulation or replacement of components which have a service life of 10 years or more. These shall have facilities to enable the purchaser to erect patent scaffolding, temporary ladders, platforms and safety nets to safely perform the work involved other than for the LTSH and economiser requirements brought out elsewhere.

2.2.15.4 Access platforms etc. shall also comply with the following requirements:

- i) Platform at same elevation on each side of steam generator shall have a walkway connecting the two sides.
- ii) Platforms requiring access from the elevator shall extend to the elevator entrance and shall be attached to the elevator steel as required.
- iii) Soot blowers shall have operating platforms along the entire length of retractable blowers and adequate space for removal, handling and maintenance of rotary blower elements shall be provided.
- iv) Provide escape ladders from any platforms having dead ends at the rear of the steam generator.

2.2.15.5 Two main stairways with clear width of minimum 1.0 m shall be provided, one on each side of the steam generator. One stair way shall extend continuously from grade to the highest operating level and the other shall extend continuously from grade to the boiler roof. Steel framing for penthouses for each stairway shall be provided. The portion of main stairway within the enclosed portion of the building, if any, shall be designed for one hour smoke/ fire proof requirements.

2.2.16 Electro Static Precipitators (ESPs)

2.2.16.1 System description

The ESPs shall be of outdoor type and installed on the cold end side of regenerative air pre-heaters. The flue gas shall be drawn from air pre-heater outlets and guided through adequately sized duct work into the specified number of independent gas streams of the ESP. Similarly, the flue gas after the ESP shall be led to the suction of the induced draft fans. The flue gas temperature may approach the economiser outlet temperature in case the regenerative air pre-heaters fail to operate. The Contractor shall take these aspects into account while designing the ESPs.

2.2.16.2 Service conditions

The steam generators are designed to burn HFO/HPS/LSHS and LDO in conjunction with pulverised coal during startup and at low loads for warm up and flame stabilisation. Further, the frequency and durations for startup and low loads operation may be quite large during unit commissioning and first year of operation. The Contractor, shall take into account the entire characteristics of expected combination of fuels to be fired and shall clearly indicate the preventive measures or equipment to be provided by him to minimise the possibility of fires in the ESPs and the features/ materials provided to avoid the corrosion of ESP components/ surfaces.

2.2.16.3 Design criteria

- i) The ESPs shall be designed to meet all the conditions specified above and specified coal and ash analysis. The precipitator parameters which are required to be satisfied are given at clause 2.1.27 and these shall be considered as minimum design criteria. The values indicated at above clause shall be modified to more conservative values if Contractor's experience warrants the same. However, no credit shall be given to the Contractor for this during evaluation of the bids. Utilisation of these values in no way shall relieve the Contractor of his responsibility to meet all the guarantee requirements. The Contractor shall also furnish the detailed calculations and data to establish as to how he meets the efficiency requirements both at design point and guarantee point as specified in clause 2.1.27.
- ii) The ESP of each unit shall be arranged in four independently operating gas streams i.e. four independent casings. Each casing shall be provided in twin compartments.
- iii) The Contractor shall furnish detailed calculations for ESP efficiency, ESP power consumption and TR set rating etc. during detailed engineering.

2.2.16.4 Justification for proposed design

- i) All the design procedures, systems, and components proposed shall have already been adequately developed and have demonstrated good reliability under similar or more arduous conditions elsewhere.
- ii) The bidder shall optimize the design of ESP for specified coal and shall furnish comprehensive information on how the specific collection area, effective migration velocity or total migration velocity of the proposed design has been arrived at. A detailed write up on design features of the proposed ESPs shall be submitted by the bidder alongwith his offer.



2.2.16.5 Location and layout requirements

- i) The Contractor shall offer the best design to accommodate the ESPs and accessories within the confines of the space available. The design shall permit satisfactory duct layout before and after the ESP terminal flanges.
- ii) ESP control room located at grade level adjacent to the ESP shall house the control cubicles. The Man Machine Interface (MMI) to be provided to enable unit control room operator to access the ESP controls for control, monitoring and data acquisition functions may be suitably located in the unit control room.

2.2.16.6 Model Study

- i) The Contractor shall conduct computer based model study using CFD technique to achieve optimum size and layout of the ducting, uniform flue gas distribution, maximum particulate collection, minimum draft loss, minimum dust drop out and build up and minimum re-entrainment from within the precipitator.
- ii) The model study shall include the design of all connecting duct work from the air preheater gas outlets to the induced draft fans inlets, induced draft fan outlet to chimney flue inlet including the inlet duct transition piece, including all dampers, turning vanes and distribution devices. Based on the model test studies, the Contractor shall finalise the design of the duct work, guide vanes, flow splitters etc. The model study shall also include a gas distribution study for the duct system around ESP to find out the effect of isolation of one stream of the ESP.
- iii) The report of CFD model study shall be furnished to the purchaser.
- iv) CFD model study for the ESP may not be needed in case the bidder has earlier carried out the CFD modeling for similar size and type of the ESP. The report of CFD model study earlier carried out by bidder for similar size and type of the ESP shall be furnished to the purchaser.

2.2.16.7 Maintenance Requirements

- i) The design of the precipitators shall allow adequate space above and between the adjacent fields to carryout necessary inspection and maintenance. A permanent walkway shall be provided at each rapping level both for the discharge and collecting plates.
- ii) Minimum 2.0 m wide platforms shall be provided between the two casings of the ESPs to facilitate maintenance work. The protection for the platform and the rapping motors from exposure to rain shall also be provided.
- iii) Three (3) nos. of staircases of minimum 0.85m clear width shall be provided from ground to the roof of the ESPs with landings connected at all platforms. One of the staircases shall be located towards the boiler side and the other two towards the chimney side of the ESPs with two adjacent staircases located on opposite ends. Further, the platforms between all the ESP casings shall be interconnected at least at one intermediate elevation.



- iv) Each compartment of four streams of ESP shall be provided with isolation dampers at inlet and outlet for carrying out maintenance work while the remaining section of ESP is in service by completely isolating it electrically and grounding it. Suitable safety interlocks etc. shall be provided.
- v) A monorail system with movable trolley and an electrically operated hoist mounted on the precipitators roof shall be provided for handling and maintenance of TR sets, rapper motors, fans (if applicable) etc. By this arrangement, it shall also be possible to lower the TR sets down to the ground level and/or onto a truck. Normal and special maintenance tools shall also be furnished for attending to different equipment.

2.2.16.8 Gas distribution system

Gas distribution system shall be provided at the precipitator inlet as well as outlet sections to achieve uniform gas distribution throughout the ESP with maximum utilisation of collection areas at the inlet and outlet. It shall be designed to minimise local velocity regions and to avoid bypassing and re-entrainment of dust. To achieve the above, internal baffles etc. shall be provided. The distribution screens shall be of modular design. The Contractor shall give full description of the gas distribution system, stating the means he proposes to keep the distribution screens clean.

2.2.16.9 Collecting plates (electrodes)

- i) Collecting plates shall be designed for dimensional stability and to maintain the collection efficiency at the specified level. The specific collection area shall in no case be less than the value specified at clause 2.1.27. The profile of the collecting plate shall be such as to minimise the re-entrainment of collected dust at the time of rapping. Minimum plate thickness shall be 18 BWG. Each plate shall be shaped in one piece construction and shall be stiff enough to carry the rapping intensity. The swaying and warping tendencies shall be prevented by suitable means. These means shall be clearly brought out in the proposal.
- ii) The collecting plate height shall in no case be higher than maximum height which has been successfully tested and proved by the Contractor or his principal for the equipment offered, over a minimum period of one (1) year of commercial operation in at least one plant, where the ESPs are operating in conjunction with a coal fired boiler under coal firing conditions. In support of the above, the Contractor shall furnish sufficient data, to the purchaser's satisfaction, with reference to the operating experience as stipulated elsewhere.

2.2.16.10 Discharge electrodes

The high tension discharge electrodes shall be of rigid frame type design, located midway between the collecting plates. The electrodes shall be self tensioned, or restrained in pipe frames. They shall be constructed from durable, corrosion and erosion resistant material. In case spiral type discharge electrodes are being offered, the material for the same shall be UHB 904 L or approved equivalent. Vertical and horizontal members shall be rigid enough to maintain the alignment of the system without warping or distortion even at elevated temperatures. Provisions made to maintain alignment of electrodes during normal operation, including rapping and thermal transients, shall be clearly brought out in the offer. However, no anti sway insulators shall be used at the bottom of the discharge electrodes frame to accomplish the above.

2.2.16.11 Rapping System

- i) Independent rapping system shall be provided for discharge electrodes and collecting plates with control systems as per the requirements specified. The rapping mechanism shall be of either electric impact type or tumbling hammer type. This shall be adjustable in frequency, intensity (for electric impact type only) and frequency (for tumbling hammer type) to provide an efficient cleaning rate. Separate rapping equipment, shall be provided for the discharge and collecting plates served by one TR set so that each mechanism can be suitably adjusted when required. It shall be so arranged that the rapping frequency can be independently set from the control room in accordance with the operating requirements. The rapping frequency range shall be adjustable in wide range and this facility shall be such that it does not require any stoppage of rapper operation. Sufficient number of rappers and rapper drives shall be provided so that minimum collection area and discharge electrode lengths are rapped at a time, which shall not be more than 4.33% of the total collection area for at least the last two fields/discharge electrode length of each field served by one TR set. The bidder shall provide necessary calculations in support of fulfilling the above requirements. The rapping system shall be designed for continuous sequential rapping to prevent puffing under any conditions of precipitator operation.
- ii) A minimum rapping acceleration of 75 g measured normal to the plane of the plate shall be imparted on all parts of all the collecting plates.
- iii) All internal parts of the rapping mechanism shall be accessible for inspection and they shall be placed on wide access passages and shall be easily accessible for operational and maintenance purposes. Major part of the rapping mechanism shall be located external to the precipitator. Necessary lubrication system shall be provided for the rapping mechanism.
- iv) The perforated plates and/or guide vanes furnished for gas distribution system shall also be provided with rapping systems. The rapping mechanism shall produce sufficient force to keep the perforated plates/guide vanes clean.

2.2.16.12 Dust hoppers

- i) Dust hoppers shall be of pyramidal type or conical as per bidder's proven practice, each having a storage capacity of minimum of eight (8) hours corresponding to the maximum ash collection rate of the field under which the hopper is being provided when two preceding fields are de-energised. The hopper capacity shall be based on the inlet dust burden, gas flow rate and gas temperature indicated at clause 2.1.27 for the design point condition while firing the maximum ash coal. Storage shall be upto a level that will not reduce the overall efficiency of the precipitator due to re-entrainment. Ash storage capacity shall be at least 10% higher than the ash storage capacity theoretically required for each dust hopper. Specific weight of ash shall be assumed as 650 kg/m³ for calculating storage capacity and 1350 kg/m³ for structural design. Further, for hopper strength and ESP structural calculations the level of ash in ESP shall be considered at least upto the top of hopper partition plane or the bottom of plates (whichever is more). The number and arrangement of dust hoppers shall be such that there is at least one dust hopper per TR set. The hoppers for all fields shall be identical in shape and size.

- ii) Hoppers shall be in welded steel plate construction. The lower 1.5 meters of each hopper shall be lined with 16 gauge or heavier stainless steel 304. All hopper internal sloping corners shall have 100 mm radius. Hopper valley angle to the horizontal shall not be less than sixty (60) degrees. Hopper outlet flanges shall be terminated at a height of 3.5 meters above the ground level to facilitate installation of fly ash removal system.
- iii) The dust hoppers shall be electrically heated upto a minimum of lower one third (1/3) of the dust hopper height but not less than 1.5 meter in height by thermostatically controlled panel type heating elements to prevent ash bridge formation. All heaters on each level shall have same wattage and be capable of maintaining internal hoppers temperature of 140⁰C or the gas temperature whichever is lower, and capacity selection of these heaters shall be as per purchaser's approval. This temperature must be maintained even when there is no flow of flue gases through the precipitator. Maximum excursion of flue gas temperature upto 300⁰C, while the air heaters are out also shall be considered for heater mechanical design. They shall be arranged in at least three groups i.e. for the lower, middle and upper half of the heated height. The heating system shall be of low watt density (less than 3W/square inch of heater area), panel type to avoid hot spots and to have more uniform distribution of heat, as are being manufactured by Bylin USA and Cooper heat UK having the heating capacity not less than 10 kW per hopper or approved equivalent and shall be complete with local panel having solid state controllers, alarms, indicating lights and test lights. The Minimum heat input shall in no case be less than 500 W/m² of hopper surface area. These heaters shall have high reliability by connecting multiple parallel circuits (not less than six), thereby ensuring that burn out of one element does not affect the other heater element. Heating element shall be Inconel or Ni-Chrome. Brass or Aluminum alloys shall be avoided. These heaters shall have design life of minimum 25 years and shall be able to withstand the thermal cycling as well as dynamic forces such as hopper poking, vibrations, sledge hammering to the hopper anvil or hopper itself. Each hopper shall be provided with separate thermostats. External surface of the hoppers shall be properly insulated.
- iv) Each hopper shall be provided with two (2) nos. of 100 mm dia poke hole in opposite directions, with threaded caps. The caps shall have flat iron bars suitable for striking with a hammer, to assist in breaking free any seized threads. The hoppers shall also be provided with suitably designed and located rapping anvils for loosening the fly ash by striking with sledgehammer. Further, two (2) nos. poking rods shall be supplied for each independent ESP passes for cleaning of choked ESP hoppers.
- v) Hopper baffles shall be designed to be capable of withstanding the unbalance of pressure created when one side of the hopper is filled with fly ash and the other side is empty. All bracing and stiffening shall be on the external side of the hoppers. Internal bracing, stiffening etc. shall not be accepted.
- vi) Each dust hopper shall be provided with a high level and a low-level dust level monitor operating on proven radio frequency measurement principle. The level monitoring system shall incorporate all the necessary accessories including two nos. level switches per hopper (one for high and other for low level), each with 2 NO + 2 NC contacts, local and remote signaling lamps and high and low level alarms. The high-level ash switch will provide contact closure and activate the alarm when the ash level reaches a level high enough to cause deterioration of ESP

performance and possibility of damage to ESP structure if not corrected. After a preset time elapses with the ash under high alarm activated, the logic shall have provisions to de-energise the TR set of the particular field of the affected ash hopper. The level control device shall be unaffected by ash build up, due to moisture or charged ash on either the hopper walls or on the probe itself.

- vii) Each hopper shall be provided with a quick opening access door of not less than 600 mm dia, if round or not less than 450 mm x 600 mm, if rectangular. Access doors shall be hinged vertically and provided with a safety chain and grounding strap. Suitable access ladders shall be provided from the walkway beneath the hoppers to facilitate approach to the access doors.
- viii) The hopper outlet shall not be less than 350 mm x 350 mm.

2.2.16.13 Casing

- i) Each of the ESP streams shall be housed in its own separate casing. The space provision shall be kept for installation of one additional field in all streams of the ESP in future, if required.
- ii) The precipitator elements shall be enclosed in gas tight, weather proof, and all welded reinforced steel plates. Sway bracing, stiffener and other local members shall be incorporated into the shell construction. The precipitator casing shall be fabricated from all welded reinforced, 5 mm minimum thickness, carbon steel plates conforming to ASTM A36/ IS-2062. The exposed surfaces shall be self-draining and seal welded to prevent ingress of moisture during monsoon.
- iii) The precipitator casing and its elements shall be designed to withstand a pressure \pm 660 mmwc at 67% of yield strength and a temperature of 200°C. The casing shall also be able to withstand excursion temperature upto 300°C that may persist for upto thirty (30) minutes on account of air pre heater failure. All the calculations shall be furnished to substantiate this. Adequate provision shall be made to accommodate thermal expansion and movements as required by the arrangement and operating conditions. The casing shall be gas tight. In order to prevent distortions, the structural design shall take care of unequal expansions. Care shall be exercised in the design and fabrication of the precipitators to reduce air in leakage to a minimum. All joints, which do not require opening during maintenance and/or inspection, shall be seal welded.
- iv) The precipitator casing and hoppers shall form a common structure reinforced to withstand the wind load (in accordance with IS: 875) and load due to dust storage in the hoppers etc.
- v) The inlet of the precipitators shall be provided with suitable flanged connections with the flue gas ducting, which shall be completely seal welded inside and outside after assembly.
- vi) Access door of quick opening type, shall be provided to allow entry to all sections of the precipitators for maintenance and access. The size of these doors shall not be less than 600 mm dia if circular or not less than 450 mm x 600 mm if rectangular. They shall be provided with safety chain and grounding strap. Doors shall be capable of being pad locked. Design shall be such as to eliminate air in leakage through the doors. All doors providing access to high voltage parts shall have warning signs permanently attached and marked "Danger High Voltage".



- vii) The precipitator shall be guided, anchored or supported by lubricated plates/roller bearings at such locations as may be required to limit precipitator, ductwork or expansion joint forces or movement. Each casing shall be restrained to grow in a radial direction from the anchor point. In case lubricated plates are used these shall be covered under all conditions of precipitator movements by 1.6 mm thick type 306 stainless steel plates.
- viii) The casing shall be gas tight. In order to prevent distortion, the structural design shall take care of unequal expansion.

2.2.16.14 Pent house covering

ESPs shall be provided with weatherproof-pent house. The pent house shall be covered continuously with corrugated GI sheet (minimum 1 mm thick) or metapoly sheet as per proven practice of the bidder.

- 2.2.16.15** Thermal insulation and cladding shall be provided conforming to requirement stipulated in the Section- 4 of this specification.



STANDARD TECHNICAL SPECIFICATION FOR MAIN PLANT PACKAGE

SECTION- 3

(STEAM TURBINE AND AUXILIARIES)

3.1 STEAM TURBINE

3.1.1 Equipment Sizing Criteria

3.1.1.1 Steam turbine rating

The steam turbine unit shall conform to the following design and duty conditions:

- | | | |
|-------|---|--|
| i) | Output under turbine maximum continuous rating (TMCR) (guaranteed output load) at generator terminals | : 500MW (or above)* |
| ii) | Turbine throttle steam pressure | : 170 kg/cm ² (abs) |
| iii) | Turbine throttle main steam temp. | : 537 °C |
| iv) | Reheat steam temp. at turbine inlet | : 565 °C |
| v) | Variations in rated steam temperature and pressure | : As per IEC 45 |
| vi) | Pressure drop in reheat circuit i.e. between HP turbine exhaust and IP turbine inlet | : 10% of HP turbine exhaust pressure (maximum) |
| vii) | a) Cooling water temperature at inlet to condenser | : 33°C ¹ |
| | b) Condenser design pressure | : 77 mm Hg (abs) ² |
| viii) | Turbine speed | : 3000 rpm. |
| ix) | Frequency variation range around rated frequency of 50 Hz | : +3% to -5%
(47.5Hz to 51.5Hz) |
| x) | DM water make up to thermal cycle under TMCR condition | : 3% of throttle steam flow |

¹ 28°C for sea water based once- through type CW system.

² 60mm Hg (abs) for sea water based once- through type CW system.



- xi) Final feed water temperature for heat rate guarantee point and TMCR condition : To be selected by the bidder based on his optimisation of the turbine cycle
- xii) Turbine protection against water induction : As per ASME-TDP-1-1985 (reaffirmed latest)

* The conditions corresponding to turbine maximum continuous rating (TMCR) shall be guaranteed output at generator terminals (after deducting all electrical power used for excitation, turbine generator control, lubrication, generator cooling and sealing, turbine gland steam exhaust, turbine generator main oil tank vapour extractor and any other such auxiliary of turbine generator) under design steam conditions with cycle make up of 3% of throttle steam flow, all extractions in operation and design back pressure.

3.1.1.2 Other Features

- i) The turbine- generator set shall be capable of continuous TMCR output under rated steam conditions, 89 mm Hg (abs)³ condenser pressure, 3% make-up and 47.5 Hz grid frequency.
- ii) The turbine shall also be capable of operating continuously with valves wide open (VWO) to swallow 105% of TMCR steam flow to the turbine at rated main steam and reheat steam parameters.
- iii) The steam turbine generator unit shall be suitable for direct connection to steam generator having no interconnection with other units either on the boiler feed water side or main steam side.
- iv) The steam turbine shall have uncontrolled extractions for regenerative feed heating based on optimised cycle of the bidder.

3.1.1.3 Operational capabilities

- i) H.P. heaters out of service : Turbine shall be capable of continuous operation under all HP heaters out of service with maximum output commensurate with boiler heat duty corresponding to 100% BMCR operation with HP heaters in service and the same shall be demonstrated.
- ii) HP heaters (one string) out of service : Turbine shall be capable of enhanced output under HP heaters (one string) out of service with boiler heat duty corresponding to 100% BMCR operation with HP heaters in service.

³ 70mmHg (abs) for sea water based once through CW system



- iii) Over pressure operation : a) Bidder shall indicate the turbine over pressurisation (under VWO) possible and ensure corresponding continuous output of TG set.
- b) Turbine shall be capable of accepting variation in steam temp. and pressure as per IEC 45 in case continuous over pressure operation is possible .
- iv) Two shift and cyclic load : Turbine shall be suitable for two shift operation and cyclic load variation.
- v) Part load and start up operation : a) Turbine shall be capable of operating on constant pressure mode as well as on variable pressure mode during part load and start up operation.
- b) TG set shall be capable of being started from cold condition to full load operating conditions in as short time as possible.
- vi) House load operation : TG set shall be capable of operating on house load during sudden total export load throw off using HP and LP bypass system. Unit shall not trip on over-speed in the event of total export load throw-off.
- vii) No. of start ups : Expected numbers of turbine generator start-ups are given below. The design of turbine generator and the associated systems shall take care of these start ups without affecting the life of equipment adversely. No component shall be stressed beyond acceptable safe stress and fatigue levels when operating under the stated duty conditions.

<u>Type of starts</u>	<u>No. of starts</u>
-----------------------	----------------------

Hot start (within 10 hours of unit shut down)	4000
---	------

Warm start (between 10 hours and 72 hours of unit shut down)	1000
--	------

Cold start (after 72 hours of unit shut down)	150
---	-----

- viii) Rate of loading/unloading
- The turbine generators shall be designed for minimum rate of loading/ unloading mentioned below without compromising on design life of pressure parts.
- a) Step load change: Minimum $\pm 15\%$
- b) Ramp rate:
- Minimum $\pm 3\%$ per minute under sliding pressure operation
 - Minimum $\pm 5\%$ per minute under constant pressure operation

3.1.2 Type of Steam Turbine

- i) The steam turbine shall be of tandem compound construction, condensing type with six (6) or seven (7) steam extractions at optimum points for regenerative feed heating. HP turbine shall be of double casing design. The HP, IP and LP casings shall be independent of each other **OR** combined HP-IP and separate LP casing(s). LP turbine may consist of two separate turbines. HP inner casing, IP casing and LP casing(s) shall be of horizontally split type. HP steam dumping device shall be provided for evacuation of steam from HP turbine to the condenser after shutdown /tripping to avoid windage.
- ii) Steam turbine shall be complete with casings, rotors, bearings, temperature detectors, couplings, steam gland seal, rotor turning gear preferably hydraulic type and having local/remote operation facility, hand barring gear, emergency stop and control valves (or combined emergency stop and control valve) and reheat stop and control valves with their servomotors, removable type steam strainers for start up and normal operation upstream of emergency stop and reheat stop valves, crossover/ cross around piping and electric motors for all its integral subsystems. Steam strainers integral with main steam emergency stop and reheat stop valves are also acceptable.
- iii) Hydraulic/pneumatic power operated quick closing non-return valves (QCNRV) and ordinary non-return valves for each extraction (except for the heater in condenser neck) including steam lines to BFP turbine drives and for each cold reheat line one hydraulic / pneumatic power operated QCNRV shall be provided. The type of actuation i.e., hydraulic/ pneumatic shall be as per the standard proven practice of the manufacturer.



3.1.3 Turbine Design and Construction

3.1.3.1 Turbine casings

The Turbine casing design shall have following features :

- i) Separate casing shall be provided with for HP, IP and LP turbines **OR** combined casing for HP-IP turbine and separate casing(s) for LP turbine.
- ii) Casings shall be symmetrical in design to minimise the effects of thermal stress and creep.
- iii) Turbine casings shall be designed for maximum pressure and temperature to be encountered during service including those specified under equipment sizing criteria. The HP and IP turbine casings shall be designed for a hydro-static test pressure of at least 50% in excess of the working pressure.
- iv) There shall be no sudden cross section changes and sharp corners leading to stress concentrations.
- v) Steam tightness of HP and IP turbine casings shall be ensured by providing horizontal joints with metal to metal contact. Steam tightness of LP turbine shall be ensured by providing suitable seals.
- vi) Steam chest support arrangement shall be of proven type and shall be capable of accepting piping forces during operation without transmitting the same to the casings.
- vii) All extractions shall preferably be from the lower half of casing and extraction branches should be welded to casings except for LP casing extractions which can be bolted connections.
- viii) Adequate drainage facility shall be provided with temperature sensing devices (in pair) in casings and drain lines for water detection and proper removal during start-up.
- ix) Pressure relief bursting diaphragms shall be provided for LP casing(s) to limit the exhaust hood pressure within a safe margin from design pressure.
- x) LP casing(s) shall be provided with completely self contained exhaust hood spray system to protect the turbine against excessive temperature due to windage at no load, low load and HP-LP bypass operations.
- xi) Inspection holes shall be provided for field balancing of rotor without dismantling the casings.
- xii) Dismantling of casing should be possible with minimum removal of insulation.



- xiii) Guide rods shall be provided to prevent damage to blades during erection and maintenance.
- xiv) Bearing inspection should be possible without necessity of dismantling the turbine casing.

3.1.3.2 Steam turbine rotors

- i) Rotors shall be of forged alloy steel.
- ii) Uniformity of material composition and strength shall be ensured by examining adequate number of test specimen.
- iii) Rotors shall be subject to heat stabilization as per SEP 1950, ASTM -A-472, or approved equivalent standards.
- iv) Dynamic balancing shall be carried out on composite rotor and blade assembly.
- v) Vibrations shall be minimized and shall be within limits as per ISO 10816 and ISO 7919.
- vi) Critical speed of composite rotor and blade assembly shall not be within $\pm 15\%$ of operating speed i.e. 3000 rpm. Bidder shall furnish studies carried out for combined critical speeds for the offered TG set.

3.1.3.3 Nozzles and blades

- i) Material of nozzles and blades shall be hard, corrosion and erosion resistant alloy steel.
- ii) Design shall ensure quick and easy site replacement of blading.
- iii) LP blade design shall be stand alone type without lacing wire.
- iv) Design of LP blades shall ensure effective removal of moisture.
- v) LP stage shall be provided with blade hardening upto 1/3 rd (minimum) of blade length and width 25 mm (minimum) or stellite as per the proven standard practice of the turbine manufacturer.
- vi) There shall be no resonance of LP blading in the continuous operating frequency range of 47.5 Hz to 51.5 Hz. The bidder shall furnish campbell diagrams for free standing stages of LP blading offered.
- vii) Free standing stages of LP turbine blades shall be independently tuned to avoid resonance frequency in the operating frequency range of 47.5 Hz to 51.5 Hz.



- viii) Stress induced in LP turbine blading due to back end steam loading under VWO conditions shall not exceed 90% of design stress value. Supporting calculations shall be furnished for the above.

3.1.3.4 Bearings

- i) The journal and thrust bearings shall have following features:
- a) Tin base babbit lining of the bearings shall be properly secured to the bearing shell.
 - b) Bearings shall be provided with pressurised oil lubrication.
 - c) Bearings shall be provided with independent supporting arrangement outside the turbine casings and with easy access.
 - d) Bearings shall be of horizontally split type with the ability to dismantle and replace lower half with minimum shaft lift.
 - e) Provision shall be made for measuring bearing temperature as near the point of heat generation as possible and for measuring the oil temperature leaving the bearing.
 - f) No oil leakage shall take through bearings.
 - g) One number portable type fire extinguisher shall be provided for the turbine bearings.
- ii) Following instrumentation shall be provided for each journal and thrust bearing:
- a) Necessary pick-ups and accessories for remote monitoring of vibrations (horizontal and vertical).
 - b) At least two nos. duplex temperature sensing elements for remote monitoring.
 - c) Local temperature indicators in each bearing lube oil drains along with RTDs for remote indication and annunciation.

3.1.3.5 Shaft couplings

- i) Shaft couplings shall be of ready disconnection type preferably through bolts.
- ii) Sufficient allowance shall be provided for taking up reaming and honning of bore holes during entire life of the machine.



3.1.3.6 Turning gear

- i) Suitable turning gear device shall be provided, either hydraulic type or motorised type, capable of continuously rotating the turbine shaft to ensure fast uniform cooling and warming during the shut down and start up respectively as per standard proven practice of bidder. The design of the turning gear shall have minimum 25% additional capacity for turning.
- ii) Turning gear shall have provision of automatic engagement/ disengagement with shaft speed decrease/ increase at preset value.
- iii) Manual hand barring facility shall also be provided for manually cranking the turbine in case of emergency including AC power failure. Availability of lube oil shall be ensured to the bearings during manual barring operation.
- iv) Instrumentation and control shall be provided for local and remote operation (from unit control room).
- v) Suitable interlocks of lubrication system shall be provided with operation of turning gear.
- vi) Suitable protection shall be provided to prevent the turning gear device from being started unless the jacking oil pump is in operation and an adequate jacking oil pressure has been established.
- vii) All other necessary interlocks and protections, as required, shall be provided.

3.1.4 Steam Admission Valves (Emergency Stop, Reheat Stop, Interceptor Stop Valves and Control Valves)

- i) Emergency stop valves
The turbine shall be equipped with two stop valves each operated by hydraulic actuator and complete with hangers, supports and piping to turbine.
- ii) Control valves
The turbine shall be equipped with suitable steam admission control valves. The actuation system shall be fail-safe whereby loss of oil pressure of hydraulically operated mechanism shall result in valve closure. The control valves shall be designed to ensure full arced admission of steam and facilitate efficient and uniform heating of turbine and its internal parts during start up.
- iii) Reheat stop valves and interceptor valves
The turbine shall be provided with two reheat steam stop valves and two interceptor valves or combined stop-cum-interceptor valves operated by hydraulic actuators and shall be complete with hangers, supports and piping to the turbine.



- iv) Design features of the valves
 - a) The valves shall be designed to allow blowing out of steam prior to startup.
 - b) The valves shall not seize under any operating condition.
 - c) Internal components of the valves shall be stellite to withstand high erosion. The valves are stable and shall not vibrate at high steam velocities.
 - d) Steam admission valves shall be located close to the turbine casing for limiting turbine over-speeding to safe limits because of entrapped steam volumes.
 - e) The valves shall be designed so as not to cause any objectionable noise and vibrations of the pipes and valves.
 - f) The valves shall be equipped with auxiliary contacts and limit switches for control interlocks and signalling. Additionally position transmitters shall be provided on control valves for remote indication and control.
 - g) Each valve shall be provided with two additional normally open (NO) potential free direct limit switch contacts in the valve closed position.
 - h) The valves shall be lagged with insulation and provided with lifting eye bolts.
 - i) Temporary and permanent steam strainers shall be provided for emergency stop and reheat stop valves. The strainers shall be arranged to permit easy inspection and cleaning. Steam strainers integral with main steam emergency stop and reheat stop valves shall also be acceptable.
 - j) The valves shall be hydraulically operated, fail safe type and equipped with test device to permit complete closing of one valve at a time while the unit is carrying load.
 - k) The valves shall close simultaneously and automatically when the overspeed governor trips and upon action of other protective devices.

3.1.5 Non-Return Valves

- i) NRVs shall be suitable for on load testing individually and shall be provided with fail safe design and shall close on loss of power.
- ii) The valves shall be full bore type designed for minimum pressure drop.
- iii) Each valve shall be provided with two sets of limit switches for both open and close position with two changeover contacts.



- iv) Based on TSR (tip speed ratio) analysis to be carried out by the successful bidder any additional requirements shall be met by him.
- v) Valves shall be of proven design w.r.t. type, size and rating offered (bidder shall furnish sufficient experience data for the same).
- vi) Valves shall close during unit trip.
- vii) The material of the NRVs shall be compatible to the material of piping on which these are mounted.

3.1.6 Insulation (Steam Turbine and BFP drive turbine)

- i) Bidder shall provide insulation and cladding for all equipment and piping with surface temperature more than 60°C.
- ii) The temperature of cold face of finished insulation shall not be greater than 60°C with ambient temperature of 40°C.
- iii) The insulation and cladding shall comply with the requirements specified in Section- 4 of this specification

3.1.7 Material Requirements

The bidder shall submit the schedule of materials used in turbine construction. The steam turbine shall be built-up using materials/components which are field proven. The materials adopted shall not be inferior to those mentioned below:

<u>Description</u>	<u>Material</u>
i) Turbine casing	
HP outer casing	GS-17 Cr. Mo V 511
HP blade carrier	GS-17 Cr. Mo. V511
IP casing	GS-22 Mo 4
LP casing	R St 37-2N.
ii) Turbine shaft and shaft coupling	
HP shaft	28 Cr Mo Ni V 59
IP shaft	30 Cr Mo Ni V 511
LP shaft	26 Ni Cr Mo V145



iii)	Moving blades	
	HP turbine first stage	X22 Cr Mo V 121
	HP turbine other stages	X 20 Cr Mo 13
	IP turbine stages	X 22 Cr Mo V 121
	LP turbine stages	X 20 Cr 13
iv)	Fixed blades	
	First stage of HP and IP turbines	X 22 Cr Mo V 121
	Other stages HP and IP turbines	X 20 Cr Mo 13
	First stage of LP turbine	X 20 Cr 13
	Other stages of LP turbine	X 20 Cr Mo 13
v)	Casing joint bolts	
	HP cylinder and IP cylinder	21 Cr Mo V 57
	LP cylinder	24 Cr Mo 5
vi)	IP and LP crossover/ cross around piping	R St 37-2 N
vii)	Turbine steam admission valves	
	Valve body	GS-17 Cr Mo V 511
	Valve spindle	X 22 Cr Mo V 121
	Valve seat	Stellited 21CrMoVNi47

3.1.8 Maintenance Requirements

- i) Wet steam washing : Each turbine shall be suitable for wet steam washing. Necessary stub connections on turbine/piping shall be provided for future connection to wet steam washing system. Recommended washing procedures shall be furnished by the bidder.
- ii) Forced cooling of turbine : Necessary equipment shall be provided for forced cooling of turbine during emergency



condition for quick access.

3.1.9 Performance Requirements

- 3.1.9.1** i) The steam TG set apart from being capable of operation on base load, shall also be suitable for two shift operation and cyclic load variations as the unit is expected to operate in automatic load-frequency control system. For catering to two shift and cyclic operation, turbine shall have following design features:
- a) Low thickness and weight of components
 - b) Uniformity and symmetry of section
 - c) Small rotor diameters
 - d) Small size horizontal flanges for casings
 - e) Thinner casing outer shells
- ii) Bidder shall provide adequate temperature measurement and other instrumentation etc. for adequately guiding the operator to regulate loading of unit to keep the thermal stresses and fatigue levels within safe limit.
- iii) TG set shall be capable of operating on constant as well as variable pressure mode. Necessary facilities shall be provided for switching over to variable pressure mode of operation from constant pressure operation and vice versa from unit control board.
- iv) During sliding pressure mode, throttle pressure shall slide from 100% to 40% of rated pressure corresponding to 30% load.
- v) Adjustable throttling reserve from 0 to 20% shall be provided.
- vi) TG set shall be capable of operating continuously with HP heaters out of service, with 89 mm Hg condenser pressure⁴, 3% make-up and auxiliary steam requirement tapped from CRH, generating maximum output without overstressing turbine components.
- vii) The peak to peak value of vibration measured on bearing housing shall be minimized and shall be within limits as per ISO 10816 and ISO 7919.
- viii) Normal DM water makeup to cycle added in the condenser hotwell shall be 3% which at times may go upto 5%.
- ix) During HP and LP bypass operation, the deaerating feed water heater and accessories shall be able to heat feed water from 45 °C to 140 °C.
- x) All cycle drains shall be led to condenser through flash tanks. In addition, the provision shall be kept for main steam line drains and HP bypass line drains to be led to a separate atmospheric flash tank.

⁴ 70 mmHg (abs) for sea water based once through CW system



- xi) Condenser shall be designed to accept additional flows from boiler during startup (as applicable).

3.1.9.2 Heat balance diagrams

- i) Following heat balances complete in all respects shall be furnished for the conditions stipulated with units indicated in MKS system and latest edition of BIS steam tables. The parameters of pressure (in ata), temperature (in °C), enthalpy (in kcal/kg) and flow (in tonnes/hour) shall be indicated at all required locations to facilitate manual checking by the purchaser.
- a) 100% TMCR output under rated steam conditions at design condenser pressure with zero make-up (guaranteed heat rate condition).
 - b) 80% TMCR output under rated steam conditions at design condenser pressure with zero make-up (guaranteed heat rate condition).
 - c) 60% TMCR output under rated steam conditions at design condenser pressure with zero make-up
 - d) 50% TMCR output under rated steam conditions at design condenser pressure with zero make-up
 - e) 30% TMCR output under rated steam conditions at design condenser pressure with zero make-up.
 - f) 100% TMCR output under rated steam conditions at design condenser pressure with 3% make-up (guaranteed output condition).
 - g) 80% TMCR output under rated steam conditions at design condenser pressure with 3% make-up.
 - h) 60% TMCR output under rated steam conditions at design condenser pressure with 3% make-up.
 - i) 50% TMCR output under rated steam conditions at design condenser pressure with 3% make-up.
 - j) 30% TMCR output under rated steam conditions at design condenser pressure with 3% make-up.
 - k) 100% TMCR output under rated steam conditions at condenser pressure of 89mm Hg (abs)⁵ with 3% make-up.
 - l) 80% TMCR output under rated steam conditions at condenser pressure of

⁵ 70 mm of Hg (abs) in case of sea water based once- through CW system



- 89mm Hg (abs)⁵ with 3% make-up.
- m) 60% TMCR output under rated steam conditions at condenser pressure of 89mm Hg (abs)⁵ with 3% make-up.
 - n) 50% TMCR output under rated steam condition at condenser pressure of 89mm Hg (abs)⁵ with 3 % make-up.
 - o) 30% TMCR output under rated steam condition at condenser pressure of 89mm Hg (abs)⁵ with 3 % make-up
 - p) VWO output under rated steam conditions at design condenser pressure with 3% make-up.
 - q) VWO output under rated steam conditions at design condenser pressure with zero percent make-up
 - r) VWO with over pressurization, if applicable, corresponding to boiler capability at design condenser pressure with 3% make-up.
 - s) VWO output under rated steam conditions at condenser pressure of 89mm Hg (abs)⁵ with 3% make-up.
 - t) 100% TMCR output under rated steam conditions with HP heaters out of service at condenser pressure of 89mm Hg (abs)⁵ with 3% make-up.
 - u) HP heaters out of service (one string and both strings) under rated steam conditions at design condenser pressure and 3% make-up and maximum output.
 - v) HP heaters out of service (one string and both strings) under rated steam conditions at condenser pressure 89mm Hg (abs)⁵ with 3 % make-up and maximum output.
 - w) 100% TMCR output under sliding pressure conditions at design condenser pressure with zero percent make-up and 3% make-up with 0% throttle reserve.
 - x) 80% TMCR output under sliding pressure conditions at design condenser pressure with zero percent make up and 3% make-up with 0% throttle reserve.
 - y) 60% TMCR output under sliding pressure conditions at design condenser pressure with zero percent make-up and 3% make-up with 0% throttle reserve.
 - z) 50% TMCR output under sliding pressure conditions at design condenser pressure with zero percent make-up and 3% make-up with 0% throttle



reserve.

- z1) 30% TMCR output under sliding pressure conditions at design condenser pressure with zero percent make-up and 3% make-up with 0% throttle reserve.
- z2) HP and LP bypass operation under rated steam conditions with 60% BMCR flow.
- z3) HP and LP bypass operation under rated steam conditions with bypass valves open to full capacity and turbine on house load operation.
- z4) 65% TMCR output under rated steam condition.
- z5) BMCR output under rated steam condition.
- z6) 60% TMCR output with one pass of condenser(s) in isolated condition

Note :

- Heat balance diagrams listed at a) to d), f), k), p) and u) above shall be furnished along with the bid. The other heat balances shall be furnished during detailed engineering.
- Heat balance diagrams for 3% make up shall depict how 3% loss is affected from the power cycle.
- Heat balance diagrams for guarantee conditions shall depict SH and RH desuperheating water flows as applicable.
- Heat balance diagrams for HP- LP bypass operation at item z3) shall be corresponding to no steam extraction (for heaters and BFP turbine) except for deaerator pegging.
- Any additional heat balances deemed necessary by the purchaser shall be furnished. All the heat balances shall show turbine output, mechanical and electrical losses in turbine and generator and input to shaft driven auxiliaries, if any.
- Steam supply to deaerator shall be from IP-LP cross over/ cross around pipe or from a point as per optimised cycle of bidder and the minimum deaerator pressure shall be 3.5 ata during low-load operation and HP-LP bypass operation. During cold startup the supply shall be from auxiliary steam header and deaerator pressure shall be maintained at 1.5 ata.
- Drive turbines of BFP shall get steam from IP-LP crossover/ cross around pipe or from a point as per optimised cycle of bidder during normal operation and from CRH line at low loads (below 60% TMCR).



- ii) The turbine cycle heat rate shall be calculated as per the formula indicated in Section-1 of this specification.
- iii) Based on cycle condition and covering entire range of operation for turbine and condenser, following correction curves for variation in turbine heat rate and output shall be furnished by the bidder:
 - a) Variation in main steam pressure and temperature.
 - b) Variation in reheat steam temperature.
 - c) Variation in CW inlet temperature and flow.
 - d) Variation in power factor, frequency, and voltage.
- iv) Following condenser pressure variation curves for change in CW inlet temperature, heat load and CW flow in condenser shall be furnished by the bidder:
 - a) Change in CW inlet temperature.
 - b) Change in net heat load.
 - c) Change in CW flow.

The above list of correction curves at (iii) and (iv) is conclusive and curves in addition to above shall not be applied.
- v) Turbine expansion line diagrams shall be furnished for various load conditions alongwith stage by stage efficiencies of turbine.
- vi) The bidder shall furnish thermal kit data for computation of plant performance by DDCMIS and true copies of performance guarantee test reports for sets rated for 100% TMCR rating or more.
- vii) The bidder shall turbine clearance diagram indicating values for radial and axial clearances and leakage rate at TMCR and under worst operating conditions.



3.2 GLAND SEALING SYSTEM FOR STEAM TURBINE AND BFP TURBINE

- i) Gland sealing system for the TG set and BFP drive turbines shall comprise of spring back labyrinth seals. However, the gland seals of BFP drive turbine may not be of spring back type and shall be as per standard practice of the turbine manufacturer.
- ii) Turbine shaft glands shall be sealed with steam. Fully automatic gland sealing steam supply system shall be provided including necessary piping, valves, fittings and control and instrumentation as required.
- iii) Gland steam condenser shall be provided to condense and return to cycle all gland leak off steam alongwith 2x100% capacity motor drive exhausters to remove air and non-condensable gases. The exhaust gases shall be discharged above the TG hall roof level.
- iv) Suitable arrangement shall be provided to bypass gland steam condenser (designed to operate under vacuum condition also) alongwith desuperheating arrangement, if required, for the bypass. The exhaust shall be discharged above the TG hall roof level. The gland steam condenser shall be provided with bypass on water side also.
- v) The gland seal material shall be of proven type.
- vi) The turbine shall be self sealing during normal operation of the unit. During startup and low load operation, sealing steam shall be supplied from high temperature or low temperature auxiliary steam header or CRH depending upon the sealing requirement. Facility shall be provided for automatic switchover from alternative source to the main source and vice versa.
- vii) During changeover of steam supply source from turbine or CRH or auxiliary steam header, there shall be no rubbing at glands and no undue increase in vibration and the system shall be capable of withstanding thermal shock.
- viii) Effective drain system shall be provided alongwith instrumentation to monitor and maintain the required temperature to avoid thermal shock to the rotor during changeover from self sealing to alternate source of sealing steam.
- ix) Two nos. modulating type control valves shall be provided, one discharging surplus steam to condenser and other for supplying extra steam to gland sealing header from steam source to maintain sealing steam header pressure at a preset value. These control valves shall be provided with electrically operated bypass valves.
- x) Control valves shall be stay put during power failure and sealing steam header pressure shall be maintained by manual control of these valves.
- xi) Gland sealing arrangement provided by the bidder shall permit easy examination and replacement of glands without lifting the upper half of the turbine casing. However, for BFP drive turbine, the arrangement for replacement of glands may be as per standard practice of the manufacturer.



3.3 TURBINE LUBRICATION OIL AND PURIFICATION SYSTEM

3.3.1 A self-contained lubricating oil system shall be provided for each TG unit and shall consist of the following:

- i) Centrifugal or gear type main oil pump (MOP) directly driven by turbine as per bidder's standard practice with capacity to cater to lube oil required for bearings and emergency seal oil requirement. The grade of oil to be used with its complete specification shall be stated by the bidder.
- ii) 2X100 % AC auxiliary oil pumps for start up, shutdown of TG unit and as standby to MOP for automatic operation, each pump having capacity to cater to lube oil and turning gear oil requirement.
- iii) 1 x 100% DC emergency oil pump for meeting lube oil requirement of bearings during emergency, with automatic starting on low lube oil pressure preset value.
- iv) 1 x 100% each AC and DC jacking oil pumps with interlocking not to start till lube oil pressure is established.
- v) Pressure transducers for monitoring pressure of jacking oil of each bearing.
- vi) One number unit lube oil tank of capacity to allow 5 to 8 oil changes per hour (at normal operating level) alongwith with 2 x 100% duty vapour extraction fans driven by explosion proof motors. The tank shall be provided with non-corrodable strainers, level indicator visible from turbine operating floor/ oil room floor, man holes, platforms, railings, necessary piping, supports and accessories etc.
- vii) 2 x 100% DM water cooled lube oil coolers with 15% excess tube surface area, designed as per TEMA having oil pressure greater than water pressure. The oil coolers shall be provided with dial type thermometers and manual 3 way valve on oil side for change over of coolers. Oil temperature at outlet of coolers shall be maintained within permissible limits as per requirement at inlet to the bearings.

Manufacturer's standard and proven system for turbine lubricating oil pumps stipulated at (i) and (ii) above with equivalent functional redundancies shall also be acceptable subject to purchaser's approval.

3.3.2 Unit Purification System

Each steam turbine shall be provided with a permanently connected, continuous oil purification system having following major equipment:

- i) Oil centrifuge having capacity to purify 20% of total oil charge in system per hour and constructed from high grade stainless steel. Purified oil shall not have any free moisture and maximum particle size shall be conforming to code 15/12 as per ISO 4406 with inlet oil quality conforming to code 21/18 as per ISO 4406.



- ii) Carbon steel anti-flood tank for each purifier.
- iii) Positive displacement feed and discharge pumps (if required), each having capacity 10% higher than purifying unit. Necessary interlock for preventing centrifuge operation in case these feed and discharge pumps are not operating shall be provided.
- iv) Indirect electric oil heater to heat oil to temperature not more than 65°C with facility to cut heater elements in steps.
- v) Entire purification equipment shall be mounted upon a suitable metal base having a raised lip around the outside with a drain connection.

3.3.3 Filters/ Strainers

Duplex type filters/strainers with stainless steel element shall be provided at common lub oil supply line of the turbine. Differential pressure switches with alarm shall be provided for the filters/ strainers. The filter element size shall be five (5) microns or a size suited to requirement of the turbine.

3.3.4 Oil Piping and Fittings

- i) Piping and all other components of system coming in contact with control fluid shall be of stainless steel.
- ii) Double oil piping or equivalent shielding arrangement shall be provided for all high pressure lines and all pipes close to hot pipes and parts to protect against fire hazards.
- iii) Oil return lines from bearings shall be fitted with illuminated sight fittings or any other device to see the flow of oil depending upon the standard proven practice of the manufacturer.
- iv) Oil supply lines to and oil return lines from bearings and generator seals should have provision for oil flushing filters. Oil flushing filters may not be provided in individual return lines if a common strainer is provided in the tank for return oil as per standard practice of the bidder.

3.3.5 Central Turbine Lubricating Oil Storage and Purification System.

A central turbine lubricating oil storage and purification system shall be provided common for both units. The system shall consist of identical dirty and clean oil tanks with capacity 1.5 times the capacity of unit oil tank, purification system identical to unit purification system and 2x100% capacity oil transfer pumps. The facility shall be provided to add new oil to any unit oil tank.



3.4 TURBINE CONTROL FLUID SYSTEM

3.4.1 Each unit shall be provided with control fluid system consisting of the following:

- i) Fire resistant fluid for control fluid system for servomotors of all hydraulically operated turbine stop and control valves, extraction NRVs and spray water valves for LP bypass system (if applicable). The grade of oil to be used with its complete specification shall be stated by the bidder.
- ii) 2 x 100% AC driven pumps connected to fluid reservoir alongwith hydraulic accumulators.
- iii) Fluid reservoir of adequate capacity fitted with non-corrodable strainers, level indications, level alarm switches and overflow devices alongwith draining and sampling connection. The surfaces of reservoir in contact with fluid shall be of stainless steel. The reservoir shall be fitted with 2 x 100% vapour extraction fans, access ladders, platforms, railings and man holes with covers etc.
- iv) 2x100% DM water cooled control fluid coolers with 15% excess tube surface area, designed as per TEMA having oil pressure greater than water pressure fitted with dial type thermometer and manual 3- way valve on oil side for change over of coolers. Oil temperature at outlet of coolers shall be maintained within permissible limits at inlet to the bearings. All surfaces coming in contact with control fluid shall be of stainless steel.
- v) Control fluid purifying unit to purify at least 2% of the total fluid charge in the system per hour on a continuous bypass basis alongwith 2x100% capacity AC driven purification pumps (for fluid circulation through purification system).
- vi) Duplex filters at down stream of all pumps having mesh size as per bidder's standard practice alongwith differential pressure switches for alarm. Alternatively, filters before each equipment requiring filtered fluid shall be provided as per standard practice of the bidder.

3.4.2 Piping and Fittings

Piping and all other components of system coming in contact with control fluid shall be of stainless steel.



3.5 TURBINE GOVERNING SYSTEM, PROTECTIVE DEVICES AND UNLOADING GEARS

3.5.1 Governing System

The steam turbine generator unit shall be equipped with an electro-hydraulic governing system with mechanical-hydraulic back up or electro-hydraulic system with 100% hot back-up as described in Section- 6 of this specification. The turbine governing system shall meet the following requirements:

- i) The governing system shall be capable of controlling with stability the turbine speed between zero to maximum power output when the unit is operating isolated or in parallel with other units.
- ii) Over speed during full load loss shall be limited to 8% of the rated speed.
- iii) Adjustable steady state speed regulation shall be provided between +3% to +8% of rated speed.
- iv) Dead band at rated speed and at any power output within rated output shall not exceed 0.06% of rated speed.

3.5.2 Speed Load Changer

The governing system shall be equipped with speed and load changers to control the speed or power output of the steam turbine within the limits. The speed/load changer provided shall be capable of adjusting the speed of the turbo set to any value in the range of 94% to 106% of rated speed for manual/auto synchronisation of the generator with the bus. It shall be capable of varying the load on the machine from no load to full load.

For remote control, suitable motor drive shall be provided. Indication of the speed/load changer position shall be provided on the operator's work station and console panel insert.

3.5.3 Load Limiting Device

The governing system shall be equipped with a load limiting device capable of being operated both locally as well as remotely from unit control room for the purpose of limiting the amount of opening of the governor controlled valves to set the load at a pre-determined limit, while the turbine is in operation. A remote position indicator shall be provided on the console panel insert for indication of the setting of the load limit. Contacts shall also be provided on the load limiter for signalling load limited operation in unit control room.



3.5.4 Turbine Protection Devices

i) **Emergency governor**

- a) Bidder shall provide a separately actuated overspeed device called quick acting emergency governor to trip the unit at 110% of rated speed in case speed governor fails to limit the turbine overspeed.
- b) The emergency governor resetting shall be as per manufacturer's standard practice. However, it shall meet the IEC-45 requirements for overspeed trip.
- c) Bidder shall provide means for testing the operation of emergency governor when the machine is on load without exceeding the rated speed of the unit.

ii) **Emergency hand trip**

Bidder shall provide emergency hand trip device on front pedestal/panel near turbine to facilitate manual tripping of the unit alongwith facility to trip turbine from UCB.

iii) **Other protection devices**

Other turbine protection devices including vacuum trip gear, solenoid trip gear and thrust bearing trip shall be provided as per standard practice of the bidder.

3.5.5 Unloading Gear

i) **Initial Pressure Regulator**

- a) Initial pressure regulator shall ensure turbine unloading to a preset point to run on house load in case main steam pressure falls below a predetermined value.
- b) It shall be possible to adjust or bypass the initial pressure regulator from UCB at start up condition to facilitate starting with low steam pressure and during sliding pressure operation.
- c) Contact shall be provided for signalling the device in 'Operation' and 'Reset'.

ii) **Low vacuum unloading gear (if applicable)**

- a) Based on the standard proven practice of the bidder, the bidder shall provide a low vacuum unloading gear which shall ensure progressive decrease of steam flow to turbine below a preset value of condenser vacuum, thus restoring the condenser vacuum.



- b) Same as i (c) above.

3.5.6 Vacuum Breaker

Bidder shall provide suitable device for rapid reduction of vacuum in condenser for turbine rotor to be brought to rest as quickly as possible. Provision shall be made to operate it both manually and through DC actuator.



3.6 TURBINE EXHAUST HOOD SPRAY CONTROL SYSTEM

Steam turbine exhaust hood spray cooling system shall be provided to permit low load operation of the turbine- generator set without excessive rise in the exhaust-hood temperature. Steam turbine exhaust hood spray cooling system shall be self-contained and complete with spray arrangements, associated piping, instrumentation and control devices, valves and fittings, motor/solenoid operated valves and specialties, hangers, supports and insulation etc. The spray arrangement shall be activated automatically under the condition of low load or exhaust hood temperature exceeding the permissible value.



3.7 WARMING UP, DRAIN, VENT SYSTEM AND FLASH TANKS

3.7.1 The bidder shall provide warming-up and drainage system for the turbine system to drain away the condensate which may be formed due to steam coming into contact with cooler metal during start-up and stagnant steam sections. The system shall comply with the requirements of ASME TDP-1, "Recommended practices for the prevention of water damage to steam turbines used for electric power generation". The drainage system shall be provided but not limited to the following:-

- i) Main steam, CRH and HRH line drains
- ii) Main steam stop and control valves
- iii) Reheat stop valves and interceptor valves
- iv) Steam lead and turbine drains
- v) Steam seal system
- vi) HP & LP bypass valves and warming up line
- vii) Turbine extraction steam piping system
- viii) BFP turbine system

The drains shall be provided for every low point with automatic disposal of collected condensate. The drains shall be connected to the flash tanks via headers. The connections on the header shall be graded according to the pressure, the farthest from the tank being the drain connection with highest pressure. The drains from main steam piping, HRH, CRH, and auxiliary steam headers etc. shall also be connected to the flash tanks described herein.

3.7.2 The following flash tanks shall be provided as a minimum to receive the drains and safety valve connections from various equipments and systems.

- i) Unit flash tank
- ii) Turbine drain flash tank (left)
- iii) Turbine drain flash tank (right)
- iv) HP drain flash tank
- v) LP drain flash tank



- 3.7.3 The arrangement for connection of various drains to the flash tanks shall be as under:
- i) The drains from MS piping and HP bypass piping including warm up line shall be connected to unit flash tank.
 - ii) The turbine integral and power cycle drains shall be connected to turbine flash tanks. The left side drains shall be connected to left side flash tank and right side drains to the right side flash tank.
 - iii) The drains from CRH, HRH, LP bypass piping including warm-up line, extractions to HP heaters, CRH and auxiliary steam to BFP turbine and deaerator (high pressure side) and drain, vent and safety valve connections on HP heaters shall be led to the HP flash tank. The drains of extractions to LP heaters, IP extractions to BFP turbine, BFP turbine integral system, CRH to BFP turbine and deaerator (low pressure side), auxiliary steam header, drain, vent and safety valve connections of LP heaters and drain coolers, deaerator overflow and CEP discharge vent shall be led to the LP flash tank.
 - iv) The drains led to HP drain flash tank, LP drain flash tank and turbine drain flash tanks shall be recovered by connecting drains and vents of these vessels to the condenser. The vents of unit flash tank shall be open to atmosphere and drains of these tanks shall be led as waste to the plant drain/ channel.

The above scheme of drain connections is indicative only. The bidder may provide alternative scheme/ arrangement for connection of drains to different flash tanks as per his standard practice which shall be subject to approval of the purchaser.

- 3.7.4 Drains shall be tapped off from main line through a drip pot with provision for removal of entrapped dirt. Each drain shall be provided with one locked open manual valve followed by one motor/ pneumatic operated leak proof angle valve on downstream side to be used for draining and warming-up the pipes as applicable. For sections having drain formation during normal plant operation such as auxiliary steam header lines and alternate steam lines to BFP turbines and deaerator, steam trap assembly shall be provided in parallel to the motorized/ pneumatic drain valve.
- 3.7.5 The drain valves shall be located in accessible positions to facilitate their maintenance.
- 3.7.6 Facility shall be provided for remote manual operation of the drain valves from the control room. Motor operated drain valves shall be interlocked to open/ close as per the process requirements. Detailed operation philosophy/interlocks shall be furnished by the bidder along with the bid.
- 3.7.7 On the CRH line downstream of NRV, a drain pot shall be provided at the lowest point in the CRH line. The following features shall be provided for drain pot valve control system:
- i) On high level in the drain pot, the motorised drain valve shall open automatically and an alarm shall be initiated in the control room. Closing of motorised valve shall be by remote manual.



- ii) On high-high level in the drain pot, an alarm shall be raised in the control room, and an automatic repeat command shall be given for opening of the motorised drain valve.
- iii) Position indication of drain valve shall be provided in the control room.

3.7.8 Flash Tanks

- i) The flash tanks shall be adequately sized to take care of the total drains in the complete power cycle piping system. There shall be sufficient margin to accommodate the possible variation in drain quantities as well as flash steam. Flash tanks shall be designed as per the requirement of ASME boiler and pressure vessels (B&PV) codes, and ANSI standard.
- ii) The design pressure and temperature for the pressure vessels (except bellows) to be designed shall be 3.5 kg/cm² and 215 °C respectively. Flash tanks shall also be designed for full vacuum condition.
- iii) Corrosion allowance of 3 mm shall be added to the design thickness of the shell and head of the vessels. The minimum thickness of the vessels including corrosion allowance shall not be less than 8 mm.
- iv) The flash tanks and manifolds shall be designed to take care of the impact forces due to incoming drains.
- v) The temperature in the flash tanks shall be maintained by using condensate spray or service water spray (for flash tanks open to atmosphere). The spray shall be automatically controlled. However, for flash tanks open to atmosphere continuous spray through an orifice shall also be acceptable.
- vi) In case the spray is in the manifold, the material for the flash tank manifolds shall conform to ASTM A335 Gr. P22 or better and its thickness shall not be less than Schedule 100 of ANSI B36.10 irrespective of temperature of the fluid handled.
- vii) Constructional features
 - a) Flash tanks shall be vertical, cylindrical design and of welded construction with torispherical or hemispherical heads.
 - b) Drain/hot water inlet nozzles shall be tangential/ radial to the vessel periphery. Suitable vortex breaker arrangement shall be made at the liquid outlet to the vessel. In case the contractor finds better alternate arrangement, the same can be submitted for the purchaser's acceptance and approval.
 - c) A manhole shall be provided on the flash tanks for inspection purpose. It shall be of minimum 500 mm diameter. The manhole shall be of devit type and shall be provided with grip.



- d) The flash tanks shall be located on the ground/ mezzanine floor of the power house. Necessary structural supports including anchor bolts shall be provided. Three support legs at 120 degree spacing shall be provided on each flash tank. Necessary lifting lugs for handling by the main plant building EOT crane shall be provided.
 - e) The flash tanks shall be provided with a full length level indicating gauge glass complete with protective rods, isolation valves and drains. Temperature indicators and temperature switches shall be provided on the flash tanks.
 - f) The flash tanks shall be provided with access ladders.
- viii) Schedule of materials

Shell and head	:	ASTM 285 Gr. C
Wear plate/ baffle	:	ASTM 285 Gr. C
Nozzle neck	:	ASTM A 106 Gr. B
Manhole nozzle flange and cover	:	ASTM 285 Gr. C
Couplings	:	ASTM A 105
Bolts and studs	:	ASTM A 193 Gr. B7
Nuts	:	ASTM A 194 Gr. 2H
Gaskets	:	Spiral wound SS 316 with graphite

In place of ASTM 285 Gr. C material, the bidder may also offer ASTM A 516 Gr 60 or IS 2062 Gr B materials provided the relevant code/standard permits use of these materials for the intended design parameters.



3.8 HP-LP STEAM TURBINE BYPASS SYSTEM

Steam turbine unit shall be provided with HP-LP bypass system with following features:

- i) HP bypass system shall be provided between MS and CRH. The HP bypass system shall have capacity not less than 60% of boiler MCR steam flow with 2x50% valves considering rated main steam parameters at upstream of valves and CRH steam parameters corresponding to 60% TMCR condition on the down stream with constant pressure operation and no steam extraction for regenerative feed heating except deaerator pegging.
- ii) LP bypass system shall be provided between HRH and condenser. The LP bypass system shall consist of 2x50% valves and shall be designed to condition the incoming steam from reheater to parameters matching with those of LP turbine exhaust steam and the capacity shall be commensurate with that of the HP bypass system plus the spray water used in HP bypass.
- iii) Seat tightness of the HP and LP bypass valves shall be equivalent to block valve tightness confirming to MSS SP61.
- iv) Complete HP-LP bypass system shall be provided with necessary control and instrumentation including all necessary positioners for continuously controlled actuators, power modules, various converters, power supply and other fault monitoring and alarming modules, position transmitters, etc.
- v) HP bypass station spray water requirement shall be supplied from boiler feed pumps discharge and LP bypass spray water requirement from condensate extraction pump discharge. Spray water system shall include spray water control valves, NRVs and isolating valves.
- vi) HP bypass shall be designed to accept continuous spray water at temperature corresponding to all HP heaters out of service and deaerator pegged at 1.5 ata. Spray water shall be sprayed at the most turbulent zone inside the valve having steam velocity in the order of 350 to 400 m/s. The entire atomization and evaporation of spray water shall be complete within shortest possible distance but not exceeding 1.0 m from the spray point. The HP bypass spray controller shall have state controller with observer to achieve accurate control over outlet steam temperature under different operating conditions including the transients.
- vii) For LP bypass system, desuperheating may be done outside the valve body with spray water tapped from condensate pump discharge.
- viii) All valves (both in steam and spray water service) shall be electro-hydraulically operated.



- ix) Control oil system(s) for HP and LP bypass systems shall be provided with 100% redundant pumps, motors, accumulators and control cubicles etc. Accumulators shall be sized to take sufficient number of stroking operations of all actuators under a condition of loss of oil supply from the pumps. The LP bypass system shall also be provided with high pressure hydraulic system to have appropriate valve opening and closing response time.
- x) Alternatively for LP bypass system, the control fluid supply can be taken from the steam turbine control fluid system based on bidder's standard practice.
- xi) HP and LP bypass valves shall be provided with gland cooling arrangement, preferably using spray water, as per manufacturer's standard practice. Further, graph-oil packing rings or equivalent arrangement shall be provided for valve glands.
- xii) Warming up arrangement shall be provided for HP and LP bypass valves and associated piping.
- xiii) HP-LP bypass system shall be suitable for operations under sliding pressure mode to enable short start up time.
- xiv) HP-LP bypass system shall be capable of operation in parallel with turbine with all feed water heaters in service.
- xv) HP-LP bypass system shall facilitate hot and warm restart of the unit following a trip from full load, part loads, controlled shutdown and cold start up following a long shutdown.
- xvi) The system design shall ensure that boiler operation is not affected in the event of loss of load on the turbine, by disposing off the steam produced in the boiler automatically by providing a quick opening device. The full stroking time of valve under quick action shall be within 2 to 3 seconds.



3.9 STEAM CONDENSING PLANT

3.9.1 General Requirements

- i) Steam condensing plant shall be of proven type with design, manufacturing and testing as per Heat Exchange Institute (HEI), USA (latest). Bidder shall furnish thermal, hydraulic and mechanical design calculations for checking equipment capability.
- ii) The steam condensing plant shall be suitable for specified condenser cooling water system (closed type with cooling towers using clarified fresh water/ sea water or once through type using sea water)⁶. As such all the materials have to be suitable for intended service.
- iii) Isolating butterfly valves and expansion bellows shall be provided at inlets and outlets of condenser cooling water on each half of the condenser.
- iv) Condenser(s) shall be designed for installation of LPH-1 in the condenser neck. The drain cooler shall be installed outside the condenser neck. Extraction pipes routed through condenser neck shall be provided with stainless steel shroud to prevent erosion due to steam.
- v) Condenser(s) shall be designed for minimum air leakage and under normal operating conditions the air leakage in the condenser(s) shall not exceed more than 50% of design value taken for sizing of vacuum pumps. The same shall be demonstrated at site under actual operating conditions, failing which bidder shall carry out necessary modifications.
- vi) For normal make up to the power cycle, DM water shall be added in the condenser hot well. The DM water shall be supplied from DM water storage tanks of DM plant, and shall be added in the hot well through a control valve. The indication for status of operating DM water supply pumps shall be provided in the UCB.
- vii) Emergency make up to the condenser hot well shall be supplied by 2x100 % centrifugal pumps of adequate capacity taking suction from the condensate storage tank which shall also receive excess flow from discharge of condensate extraction pumps. The condensate storage tank shall be of epoxy coated mild steel to IS 2062 Gr- B and its capacity shall be to meet 12 hour normal make up requirement of the unit subject to a minimum effective storage of 600 m³.
- viii) Separate sponge rubber ball type condenser on-load tube cleaning system (COLTCS) shall be provided for each half of the condenser including ball circulation pumps, strainer, ball monitoring system etc.

⁶ Purchaser to delete what is not applicable.



- ix) Maximum oxygen content of condensate leaving the condenser shall be 0.015 cc per litre over 50-100% load range.
- x) Condensate temperature at all loads shall not be less than the saturation temperature corresponding to condenser pressure.

3.9.2 Condenser(s)

3.9.2.1 Equipment sizing criteria

- i) The steam condensing plant shall be designed, manufactured and tested as per HEI (latest edition). The condenser(s) shall be designed for heat load corresponding to unit operation for valves wide open (VWO) conditions, 3% make-up, design condenser pressure and other conditions specified in clause 3.9.2.2 and 3.9.2.4 below. The value of design condenser pressure to be measured at 300 mm above the top row of condenser tubes shall be guaranteed under VWO condition, 3% make-up, design CW inlet temperature and CW flow. The condenser vacuum shall be measured with a vacuum grid utilising ASME basket tips.
- ii) The condenser hotwell shall be sized for three (3) minute storage capacity (between normal and low-low level) of total design flow with the turbine operating at VWO condition, 3% make-up, design condenser pressure. The low-low level of hotwell shall be at least 200 mm above the bottom of hotwell.

3.9.2.2 Design parameters for condenser and associated systems

- i) Condenser design parameters:
 - a) Number of passes : Single pass/ double pass
 - b) Design cold water temp. : 33⁰C⁷
 - c) Min. size (OD) of the tube : 22.225mm
 - d) Minimum thickness of the tube : 22 BWG
 - e) Tube velocity : 1.6 to 2.2 m/sec
 - f) Design condenser pressure : 77 mm Hg (abs)⁸
 - g) Max. tube length between tube plates : 15 meters
 - h) Temperature rise of circulating water across the condenser : 8 to 10 deg C⁹

⁷ 28⁰C for sea water based once- through type CW system.

⁸ 60mm Hg (abs) for sea water based once- through type CW system.

⁹ Not to exceed 7⁰C for sea water based once- through type CW system



i)	Tube material	:	Stainless steel ASTM A249 TP304 ¹⁰
j)	Cleanliness factor	:	0.9
k)	Fouling factors	:	As per HEI
l)	Tube plug margin	:	5% under design condenser condition
m)	Max. CW side pressure drop across bidder's terminal points with tube cleaning system in operation	:	6 mwc
n)	Maximum temperature of circulating water	:	36 deg C ¹¹
o)	Condenser arrangement	:	Perpendicular to TG axis
ii)	Water box design pressure	:	5.0 kg/cm ² (g)
iii)	Water box test pressure	:	1.3 times the design pressure
iv)	Water box design temperature	:	60 ⁰ C
v)	Shell side design pressure	:	Full vacuum and 1.08 kg/cm ² (g)
vi)	Shell side design temperature	:	120 ⁰ C
vii)	Design parameters for expansion joints		
a)	Design pressure	:	Vacuum (0.1 kg/ cm ² (abs)) and 5 kg/ cm ² (g)
b)	Design temperature	:	60 ⁰ C
c)	Test pressure	:	1.3 times the design pressure (minimum)
viii)	Design parameters of isolating butterfly valves with actuator		
a)	Design pressure	:	Vacuum (0.1 kg/ cm ² (abs)) and 5 kg/cm ² (g)

¹⁰ Titanium for sea water

¹¹ 31⁰C for sea water based once- through type CW system

- b) Design temperature : 60⁰C
- c) Test pressure : 1.3 times the design pressure (minimum)
- ix) Condenser air evacuation system design parameters:
- a) Source of vacuum pump heat exchanger cooling water : Condenser cooling water
- b) Source of sealing water : Condensate
- c) Source of make-up water : Condensate
- d) Design pressure (cooling water side) for vacuum pump heat exchanger : Vacuum (0.1 kg/ cm² (abs)) and 5 kg/ cm² (g)
- e) Pressure of make-up water : CEP discharge pressure
- f) Maximum temperature of condenser cooling water : 36⁰C
- g) Duty code : HEI
- h) Design back pressure : 25.4 mm (1 inch) of Hg (abs)
- x) Design pressure for CW piping, valves fittings, COLTCS equipment etc. : Vacuum (0.1 kg/cm² (abs)) and 5 kg/cm² (g) (minimum)

3.9.2.3 Construction

- i) The condenser shall be of horizontal surface type with divided water box construction and shall be provided with integral air cooling section.
- ii) Large box type screening structure with the anti-vortex baffling shall be provided at each hotwell connection to suction of condensate pumps.
- iii) Shell material shall be carbon steel conforming to ASTM A-285 Gr. C/ IS 2062 or equivalent and suitable for intended service, welded construction and 16mm minimum wall thickness. The hotwell shall be of same material as that of the shell and shall be longitudinally divided with proper drainage provisions.
- iv) Condenser shall be spring supported and directly welded to the turbine exhaust. Alternatively condenser can be solid supported with expansion joints (of fully stabilised austenitic stainless steel all welded type) in the condenser neck.



- v) Suitable impingement guards or baffles shall be provided on top row tubes. Similar guards shall also be provided for any steam or water connection to condenser. Other alternate arrangements to protect the top row of tubes can also be considered with the approval of purchaser.
- vi) Condenser(s) shall be provided with easily removable/hinged type and refittable type water boxes alongwith suitable handling arrangement for the same. Hinged manhole (of minimum 460 mm size) shall be provided in shell, each water box and each hotwell section.
- vii) Adequate provisions shall be made for future installation of cathodic protection in water box, condenser on-load tube cleaning system, and other components of CW system to protect against corrosion.
- viii) For fresh water based application, tubes shall be of welded type stainless steel as per ASTM-A-249-TP304 and meeting the ASME specification for general requirements for carbon ferritic alloy and austenitic alloy steel tubes SA-450 and continuous without any circumferential joint suitable for the duty intended, with average wall thickness of minimum 22 BWG¹². Top rows of tubes shall be extra thick. Provision for taking care of thermal expansion of tube bundle and proper drainage of tubes during shut down shall be ensured.
- ix) Water box, tube plates and support plates material shall be carbon steel as per ASTM A-285 Gr. C/ IS 2062 or equivalent and suitable for duty intended. Water box interiors shall be painted with two coats of corrosion resistant primer and coated with coal tar epoxy paint.¹³
- x) Corrosion allowance of minimum 3.2 mm for water boxes, tube plates and 1.6 mm for shell, hotwell and condenser neck shall be provided.
- xi) All bolts, nuts and stays etc. inside the steam space shall be of approved material and where such parts project through tube plates they shall be fitted with stainless steel or approved cap nuts and protective sleeves. For deaerating zone, trays, fittings etc. made of stainless steel shall be provided.
- xii) Stand pipes shall be provided with necessary connections for instruments, with water level gauges and isolation valves.
- xiii) Condenser design shall provide for efficient steam distribution in the condenser when one half of condenser is isolated and shall ensure atleast 60% of rated output under this condition.
- xiv) Suitable provisions shall be made for expansion between shell and tube.

¹² For sea water application, the tubes shall be of titanium B- 338 Gr- II and continuous without any circumferential joint with average wall thickness of minimum 22 BWG.

¹³ For sea water application, materials shall be of proven type as per duty involved and shall be compatible with titanium tubes. The materials proposed shall be subject to approval of the purchaser.



- xv) Suitable provisions (like sliding and fixed base plate of condenser support feet etc.) shall be made for expansion of condenser shell under various operating conditions.

3.9.2.4 Other features

- i) Condenser shall be designed to receive exhaust steam from steam turbine, BFP drive turbine, HP-LP bypass system, heater drains and vents, drains during start-up, low-load and abnormal conditions.
- ii) Steam dumping device shall be provided for dumping of desuperheated steam from LP bypass. Sizing of steam dumping device shall be adequate to accept the steam from HP-LP bypass with necessary spray water including abnormal condition like HP heaters out of service etc.
- iii) Air removal section shall be designed to cool the air and vapour mixture to at least 4.17°C below saturation temperature corresponding to 25.4mm Hg (abs). Connections to air evacuation pumps shall be made at this section.
- iv) Condenser shall be designed to carry flooded weight (upto tip of last stage of LP turbine blades) for hydraulic and hydrostatic testing of condenser without installation of temporary supports or bracing.
- v) CW butterfly valves with actuators shall be designed as per AWWA-C-504-80 or purchaser approved equivalent standards. Valve material shall be suitable for the duty intended.
- vi) CW expansion joints shall be made from high quality natural/synthetic rubber with stainless steel reinforcement rings and with flanges of 125 lb as per ANSI B16.25. The materials used shall be suitable for service intended. The expansion joints shall be designed to the deflection fluid pressures through out plant life and shall be suitable to withstand full vacuum without collapse and the proposed arrangement for this shall be indicated in the offer. Further the design shall limit the reaction forces/ moments on condenser CW nozzles and on CW piping.
- vii) Material of construction for CW piping and butterfly valves shall be suitable for the duty involved and shall conform to the relevant standards.¹⁴
- viii) There shall not be any damaging effect due to vibrations during normal, abnormal and transient conditions and during turbine trip from full load to HP-LP bypass operation. Satisfactory operation under all operating conditions shall be ensured including HP-LP bypass operation, feed heaters out of operation, VWO condition, 100% load and start-up conditions etc.
- ix) Natural frequency shall be well above the frequencies induced by other associated equipment under all operating conditions including abnormal conditions.

¹⁴ GRP/ FRP/ MSRL for sea water application.



- x) Condenser design shall provide for maximum deaeration and removal of non-condensable gases from steam and make-up water. Air removal section shall be suitably baffled to prevent water carryover.
- xi) Air release valves and vacuum priming pumps (if applicable) shall be provided in the waterbox of the condenser.
- xii) Condenser shall be provided with arrangement for complete drainage of water from the hotwell.
- xiii) Catch trough shall be provided below tube sheet in hotwell for detection of water leakage into steam side.
- xiv) Motorised butterfly valve shall be provided in each exhaust duct of BFP turbine for isolation of BFPT, when not in use.

3.9.3 Condenser Air Evacuation Pumps

3.9.3.1 Equipment sizing criteria

- i) Each unit shall be provided with 2x100% vacuum pumps with all accessories for condenser air evacuation.
- ii) Pumps shall be sized as per latest HEI requirements. Capacity of each pump in free dry air at standard condition with condenser operating at design pressure of 1 inch (25.4 mm) of Hg (abs) and sub-cooled to 4.17⁰C below temperature corresponding to absolute suction pressure shall not be less than 30 scfm (51 m³ per hour) under standard condition (i.e 760 mm of Hg (abs) and 21.1⁰C). The capacity of each pump during hogging shall be as per criteria given in latest version of HEI plus 20% margin.

3.9.3.2 Technical requirements

- i) Air evacuation pumps shall be single/two stage liquid ring type with both stages (if two stage pump required) mounted on a common shaft. The pumps shall be suitable for indoor installation and for continuous duty.
- ii) Each pump and its accessories shall be mounted on common steel base plate. Pump shall be connected to its motor by flexible couplings.
- iii) Heat exchangers shall be shell and tube type with tubes of SS 316, and shell and tube plates of ASTM-A285 Gr. C¹⁵. For U-tube type heat exchangers, the tube bundle shall be of removable type.

Alternatively, plate type heat exchangers with SS 316 plates and 20% area margin on plates shall also be acceptable¹⁶.

¹⁵ For seawater application, the material of tubes shall be titanium. The material of shell and tube plates shall be of proven type as per duty involved and shall be subject to approval of the purchaser.

¹⁶ For seawater application, the plates shall be of titanium.



- iv) Selection of materials for vacuum pumps and seal water recirculation pump shall be as below:
 - a) Casing : Nickel cast iron
 - b) Shaft : Carbon steel (EN8)
 - c) Impeller : Nodular iron/stainless steel
 - d) Shaft sleeves : Nodular iron/stainless steel
- v) Air evacuation pumps shall be designed for vibration levels as per VDI – 2056.
- vi) Flexibility shall be provided for operating both pumps during hogging and must be able to evacuate the condenser in specified time as per HEI.
- vii) Standby pump shall cut-in automatically in case running pump fails or when condenser pressure falls back to a preset value.
- viii) Each pump shall be suitable for evacuating 100% designed air steam mixture and non-condensable gas as per HEI.
- ix) Pumps shall be designed for no cavitation under all operating conditions.

3.9.4 Condensate Extraction Pumps

Each unit shall be provided with 3x50% condensate extraction pumps.

3.9.4.1 Sizing criteria

- i) Design capacity

Combined flow of 2x50% condensate extraction pumps shall be based on 15% margin over highest Condensate flow envisaged during unit operation (excluding HP-LP bypass operation).
- ii) Design Head

Design head shall be corresponding to (a) above considering 10% margin on deaerator pressure.
- iii) Best efficiency point

Best efficiency point shall correspond to 100% TMCR under rated condition.
- iv) Maximum capability

One pump shall be capable of handling the flow and head corresponding to 65% unit load.



- v) Other capabilities
 - a) Two pumps shall be capable of handling the flow corresponding to 100% TMCR, HP heaters out, 3% make-up and worst condenser pressure at 47.5 Hz.
 - b) Two pumps shall be capable of handling the flow corresponding to HP-LP by pass operation with turbine under tripped condition as well as turbine on house load so as not to fall into over-discharge trip due to rapid action of the LP turbine bypass de-superheater spray.

vi) Motor rating

Motor rating at 50⁰C ambient temperature shall not be less than the maximum load demand of its driven equipment in its entire range of operation at frequency variations from 47.5Hz to 51.5Hz, and motor shall not be overloaded during any mode of operations of driven equipment.

3.9.4.2 Technical requirements

i) Drive

Pump shall be driven by constant speed squirrel cage induction motor with speed of 1500 rpm (synchronous).

ii) Constructional requirements

Pumps shall be vertical, centrifugal, multistage, cannister type, diffuser type with double suction first stage impeller.

iii) Shaft sealing

Shaft sealing shall be either by mechanical seals or packed type with external water sealing designed to prevent air ingress into condenser even when the pump under shut down and exposed to condenser.

iv) End Connections

Discharge and suction connections shall be of weld neck type with raised steel flange as per ANSI B 16.5 and shall be located above floor mounting flange.

v) Thrust bearing

Thrust bearing shall be provided for the combined thrust load of pump and motor with a rigid coupling between pump and motor or individual thrust bearings shall be provided for pump and motor with a flexible coupling between motor and pump.



vi) Impeller and casing design

Pump impellers shall be of closed and non over-loading type with wear rings provided on pump casing bowls.

vii) NPSH margin

NPSH(R) at 3% head drop shall be not more than half the NPSH(A) at design flow with lowest hot well level and maximum pressure drop across suction strainer. Under all other operating regimes, the NPSH(R) at 3% head break shall be well below NPSH(A).

viii) Motor bottom level

Bottom of motor shall be above zero metre level by suitably considering the pit level and motor stool dimensions.

ix) Minimum recirculation flow

Minimum recirculation flow requirements of the pump shall not be less than 25% of design flow or on set recirculation (discharge/suction) whichever is higher.

x) Performance curve

Characteristic curve of pumps shall be continuously rising type with decrease in flow and shut off head shall be between 115 to 125% of total developed head (TDH) at design point.

xi) Critical speed

First critical speed of the pump shall not be within 20% of design speed.

xii) First stage impeller life

The wear life due to cavitation for first stage impeller shall not be less than 40,000 running hours.

xiii) Peripheral speed

Peripheral speed of the impellers shall not exceed 20m/s.

xiv) Suction specific speed

Suction specific speed of first stage impeller shall not exceed 11,000 U.S. units based on 3% head break of that impeller.



xv) Interchangeability

Complete interchangeability shall be ensured in all respect for the pumps, motor and their components.

xvi) Design pressure

a) Bowls and discharge components shall be designed for pressure corresponding to shut off head at 51.5 Hz, operating specific gravity and maximum suction condition.

b) Suction components shall be designed for 8 kg/cm² pressure and full vacuum.

xvii) The pump internals shall be capable of being lifted out of casing after removal of motor and disconnecting discharge flange but without disturbing the discharge piping.

xviii) Materials

a) Suction bell/pump casing : Cast iron

b) Impeller/wear rings/shaft/ shaft sleeves : 12% Cr stainless steel.

c) Cannister : Fabricated mild steel.

xix) Applicable code

The pumps shall be designed as per latest edition of Hydraulic Institute Standards (HIS), USA.

3.9.4.3 Strainers at suction of condensate extraction pumps

i) Strainer shall be provided on suction line of each pump.

ii) Strainer body shall be of simplex and cylindrical type.

iii) The clear area of strainer shall be five times the inlet cross sectional area of the connecting piping.

iv) Strainers shall be constructed of 16 gauge perforated stainless steel plates (304 grade) and shall be lined with stainless steel (316 grade) screen.

v) The pressure drop of the strainer at design flow and clean condition shall not exceed 0.1kg/cm². Pressure drop at design flow and 50% clogged condition shall not exceed 0.15 kg/cm².

vi) Strainers shall be designed to permit ease of inspection and cleanliness.



3.9.5 Condenser On Load Tube Cleaning System (COLTCS)

- i) COLTCS shall be of sponge rubber ball type designed for continuous and trouble free operation. Provision of abrasive coated balls shall be made for cleaning in case of hard deposits inside tubes.
- ii) The system shall consist of non-clog type ball recirculation pump, ball injection nozzles, ball collecting vessel, ball monitoring system, necessary instruments, pipings and accessories etc.
- iii) Provision of manual and automatic back wash arrangement shall be made with automatic collection of balls prior to back washing.
- iv) Ball monitoring system shall include ball circulation monitor, oversize monitor and ball sorter.
- v) The ball collecting strainer shall have differential pressure transmitter with back-washing system.
- vi) Provision shall be made to prevent loss of balls under normal and abnormal operation including tripping of CW pumps.
- vii) The no. of balls in circulation shall be at least 10% of no. of condenser tubes. Bidder shall indicate no. of ball losses in 1000 hours of normal operation.
- viii) Provision shall be made to avoid any dead zone inside water box. There shall not be crowding of balls at the inlet of ball collecting strainer at discharge pipe.

3.9.6 Debris Filters¹⁷

- i) Two number debris filters shall be provided on the circulating water pipelines upstream of the condenser for online filtering of cooling water.
- ii) Each debris filter shall comprise of perforated stainless steel screen, butterfly valves, turbulence flap, debris flushing valve, drain plug valve, motor actuators for the valves, differential pressure gauge and control and instrumentation etc.
- iii) The materials of construction of various components shall be of proven type as per quality of water to be handled by the debris filters. Inside surface of the debris filters shall be coated with anti-corrosive paint to ensure long life.
- iv) The filters shall be capable of removing solids, suspended matter and fibrous material up to 5 mm size.
- v) The removed debris shall be suitably disposed off.

¹⁷ Applicable for sea water based once- through system and also for seawater based cooling tower system.



- vi) The operation of the debris filters shall be of automatic type with facility provided for remote manual operation also.
- vii) The maximum allowable pressure drop under clean screen condition shall be limited to 0.5 mwc, and under 50% choked screen condition the pressure drop shall not exceed 1.0 mwc. The filter shall be designed for pressure of 5 kg/cm² (g) and vacuum of 0.1 kg/cm² (abs).



3.10 FEED WATER HEATING PLANT

3.10.1 Equipment Sizing Criteria

- i) The plant shall be designed in accordance with the latest applicable requirements of ASME boiler and pressure vessels (B&PV) codes, Sec-VIII, Division-I, Heat Exchange Institute (HEI) Standards (USA) or any approved equivalent standards. In addition the requirements of ASME-TDP-I-1985 (latest) code for turbine damage prevention shall also be taken care of.
- ii) The plant shall be suitable for operation in conjunction with the turbine offered. It shall be capable of raising the temperature of feed water from that in the condenser to the design value at the outlet of top heater at rated output with zero percent make-up and design back pressure.
- iii) TTDs and DCAs of heaters shall correspond to the heat rate guarantee conditions.
- iv) Velocity of water through the tubes shall be restricted to 3.05 m/s under all operating conditions.
- v) Each of the HP heaters, LP heaters and drain cooler shall be capable of handling 110% of the design flows from 2x50% BFPs, 2x50% CEPs as the case may be without undue vibration and other deleterious effects.
- vi) The heater shell side design pressure shall be not less than the maximum extraction steam pressure. It shall also be designed for full vacuum. For LP heaters, the minimum shell design pressure shall be not less than 3 kg/cm² (g). For the HP heater taking extraction from CRH line, heater shell design pressure shall be same as CRH line design pressure. For the HP heater taking extraction from HP turbine, the heater shell design pressure shall be at least 15% higher than maximum pressure of extraction stream under all operating conditions.
- vii) Heater tubes shall be designed for shut off head of BFP/CEP at maximum speed (as the case may be) and full vacuum. Alternatively, if feed control station is located at upstream of HP heaters and feed water system is designed without economizer inlet isolation valve, the HP heaters can be designed based on boiler design pressure meeting IBR requirement with provision of mechanical relief device to prevent BFP shut off pressure being communicated to the feed water system.
- viii) The deaerator shall be spray cum tray type or spray type. The deaerator shall be designed such that maximum oxygen content at deaerator outlet shall be 0.005 cc/litre measured as per ASTM D-888 reference method-A or Indigo Carmine method at all operating conditions.
- ix) The feed water storage tank capacity shall be as minimum 6minute storage of 100% BMCR flow between normal operating level and low-low level with a filling factor of 0.66. It shall be designed for maximum incoming steam flow when none of the LP heaters are working under HP-LP bypass condition.



3.10.2 General Requirements

- i) The HP heater drips shall normally be cascaded to successively lower pressure HP heaters and lowest pressure HP heater drip shall be led to the deaerator. The LP heater drips shall be cascaded to successively lower LP heaters and lowest LP heater drip shall be led to the condenser. All other LP drips shall be finally led to the condenser. Alternative heater drains shall be directly led to condenser in case of high - high level in the heaters.
- ii) Heaters shall be designed for all operating conditions including transients like sudden load throw-off, HP-LP bypass coming in the operation, preceding one or two heaters going out of service etc.
- iii) Each heater shall be designed for removal from service individually without shutdown of unit, using hydraulically operated or motorised bypass and isolating valves. In case, HP heaters are offered in two strings, these shall be isolated as a string and not individually.
- iv) Heaters shall be designed with minimum pressure drop on tube side.
- v) Heaters shall be designed for handling drains from proceeding heaters for all operating conditions and under emergency condition drains shall be led to condenser bypassing the drain cooling zone.
- vi) Heater installation shall be easy for floor mounting and shell removal dismantling except for LP heater in condenser neck.
- vii) Provision shall be made for complete drainage of heaters both on shell side and tube (water box) side.
- viii) Heaters shall be provided with start-up and operating vents with orifices and relief valves. Provision shall be made for removing non condensable gases collecting on shell side individually to the condenser. Vent orifices shall be sized to pass one half percent of rated steam flow to respective heater.
- ix) Tube material shall be stainless steel as per ASTM A 213 Gr. TP 304 for seamless tubes without circumferential joints and ASTM A 688 Gr. TP 304 for welded tubes.
- x) Tube sheet shall be of carbon steel as per ASTM A 266 Class II or SA 350-LF-2 or SA 516 Gr- 70 or equivalent and shall be welded to shell and water box. Tube support plates shall be of common quality steel of 16 mm (minimum) thickness.
- xi) Water box channels shall have access openings of minimum 450 mm diameter. These shall be of self sealing type and bolted design shall not be acceptable.
- xii) Superheated steam shall not come in contact with tube plate and joint at entry to the heaters.



- xiii) arrangement shall be provided for preservation by nitrogen blanketing during shut down.
- xiv) Tube size shall be minimum 15.875 mm OD and minimum wall thickness shall be as per HEI.
- xv) Minimum fouling resistance on tube inside shall be taken as $0.00004098 \text{ hr-m}^2\text{-}^\circ\text{C/ kcal}$ and $0.000061475 \text{ hr-m}^2\text{-}^\circ\text{C/ kcal}$ on tube outside as per HEI.
- xvi) Corrosion allowance of minimum 3.2 mm shall be considered for shell and water box of each heater.
- xvii) Stand pipes shall be provided with necessary connections for instruments and water level gauges with isolation valves.
- xviii) Proper drainage of bled steam lines shall be ensured. Each bled steam line shall have ordinary and power assisted NRVs and motorised isolation valves except for heater mounted in condenser neck and extraction to heater from CRH line.
- xix) Adequate baffling shall be provided to prevent vibrations. Uniform distribution of steam and free drainage of condensate shall be ensured.
- xx) Pass partition plates shall be provided to facilitate easy removal and access to tube sheet.
- xxi) Heaters shall be designed to have minimum space requirement for withdrawal of tube nest/ shell as the case may be.
- xxii) Sentinel relief valves shall be provided on tube side. Relief valves on shell side shall be sized to pass flow from two ruptured tubes (four open ends) or 10% of design water flow at 10% accumulation which ever is higher and set to open at heater design pressure.
- xxiii) No copper or brass shall be used in the internal construction of heaters to avoid copper pick up through condensate/drips.

3.10.3 LP Heaters and Drain Cooler

- i) LP heaters shall be of horizontal U-tube type with integral drain coolers except for LP heater- 1 in the condenser neck. LP heater- 1 may be provided with straight or U tubes.
- ii) Shell material shall be rolled steel as per ASTM A-516 Gr.70 or equivalent with SS-304 bands at cut points on shell to prevent damage against flame impingement during torch cutting.



- iii) Water box channel shall be of carbon steel as per ASTM A-516 Gr. 70 or equivalent and shall be welded to tube sheet.
- iv) Roller supports shall be provided for shell removal of all heaters except LP heater-1 and for LPH-1 heater roller supports shall be provided for heater channel during tube bundle removal.
- v) Shell attachments shall be provided for supports of LP heater- 1 in the condenser neck. Anti-flash baffles shall be provided to protect the turbine from water ingress.
- vi) LP heaters shall have provision of integral desuperheating, condensing and drain cooling zones except for LP heater- 1 mounted in condenser neck which has a separate drain cooler.
- vii) Provision shall be made for differential expansion between shell and tubes.
- viii) Details of tube sheets, tube to tube sheet joint, tube support plates and material of construction for drain cooler shall be identical to the LP heaters.

3.10.4 Deaerator

- i) Deaerator shall be of horizontal, spray-cum-tray type with integral vent condenser mounted on horizontal storage tank. Alternatively, deaerator may be of spray type with minimum two (2) spray control valves of disc type or equivalent.
- ii) Design and construction shall be as per IBR, ASME code for unfired pressure vessels, Section-VIII or any other equivalent code subject to approval of purchaser.
- iii) Reinforced wide mesh strainer and anti-vortex baffles shall be provided at discharge connections from deaerator.
- iv) Fixed and saddle supports shall be provided on deaerator storage tank.
- v) All pressure parts like shell, heads and nozzles shall be of carbon steel as per ASTM A 515 Gr. 70. Shell plate shall be of minimum 15.8 mm thickness in welded construction.
- vi) Hardened 400 series stainless steel impingement plates shall be provided for flashed drain inlet from HP heaters, BFP recirculation, boiler start-up drains etc.
- vii) All water spray valves, splash plates, trays, vent condenser and other elements in contact with undeaerated water or non-condensable gases shall be of stainless steel 304.
- viii) Deaerator safety valves of adequate relieving capacity shall be made of 13% Cr. stainless steel disc and spindle.



- ix) Deaerator shall be designed for efficient steam distribution and deaeration of condensate under all operating conditions including VWO, 3% make up, HP-LP bypass, one string/both strings of HP heater out of service.
- x) The deaerator shall be of floating pressure type with pegging pressure of 3.5 ata during warm and hot startup, HP-LP bypass operation, major load rejection, turbine trip and low loads when extraction steam pressure is less than 3.5 ata. During cold startup the deaerator pressure shall be maintained at 1.5 ata with steam from auxiliary steam header. Deaerator pressure shall vary with load when it gets steam from turbine extraction. Design pressure and temperature shall not be less than extraction steam/CRH pressure or worst operating condition with sufficient margins above the same.
- xi) Sources for heating:
 - a) Extraction steam from turbine IP-LP cross over pipe (normal operation)
 - b) Steam from CRH (upto 60% loads)
 - c) Steam from auxiliary steam header (Initial heating and low loads)
- xii) Maximum temperature difference between effluent and saturation temperature of incoming steam shall be 0.56°C at all load conditions.
- xiii) Free carbon dioxide as measured by APH method shall be non-traceable at all loads.
- xiv) Corrosion allowance of 3.2 mm shall be considered for shell thickness.
- xv) Sparger pipe and nozzle shall be provided for feed water heating.
- xvi) Vent orifice shall be sized for capacity equal to 0.5% of rated flow to the deaerator.
- xvii) Deaerator shall be sized for handling all incoming condensate from LP heaters and drips from HP heaters.
- xviii) Access platforms and ladders alongwith hand rails shall be provided on deaerator and storage tank.
- xix) Manholes of minimum 450 mm diameter shall be provided on deaerator and storage tank for access to and removal of internals including trays.



3.10.5 HP Heaters

- i) HP heaters shall be of horizontal, U-tube type with integral desuperheating, condensing and drain cooling sections. HP heaters can also be provided in two half capacity banks as per bidder's standard proven practice.
- ii) Shell material shall be carbon steel as per ASTM A-516 Gr. 70. Water box channel shall be as per ASTM A-266 class-II and shall be welded to tube sheet.
- iii) Roller supports shall be provided for removal of shell.
- iv) Tubes shall be welded to tube sheets and then roller expanded.
- v) Level of condensate in the heaters shall be maintained in the pre-set range.
- vi) Provision shall be made for differential expansion between shell and tubes.



3.11 BOILER FEED PUMPS (BFPs)

Each unit shall be provided with 2x50% turbine driven boiler feed pumps (normally working) and 1x50% motor driven boiler feed pump (standby). Each pump shall be provided with booster pump to meet the net positive suction head (NPSH) requirement of the main pump.

3.11.1 Sizing Criteria

i) Design capacity

The combined flow of 2x50% boiler feed pumps shall have 10% margin over feed flow corresponding to turbine VWO condition, 3% makeup, design back pressure and corresponding head. One pump shall be capable of handling the flow and head corresponding to 65% of unit load.

ii) Best efficiency point

The best efficiency point of the pump shall correspond to 100% TMCR under rated condition.

iii) Emergency point

Two feed pumps shall be capable of generating the discharge pressure not less than 3% over steam generator highest safety valve set pressure corresponding to 105% of boiler maximum continuous rating.

iv) Shut off head

The shut off head of the pumps shall be between 120% and 130% of total developed head (TDH) under rated condition.

v) Motor rating for MDBFP

The maximum continuous motor rating corresponding to maximum cooling water temperature to cooler inlet shall not be less than the maximum load demand of driven equipment at its entire range of operation at frequency variations from 47.5 Hz to 51.5 Hz and motor shall not be overloaded during any mode of operations of the driven equipment.

Note: Discharge flow of the pump shall not include any seal flow, warm up flow and balance drum leakage flow.



3.11.2 Design Aspects

i) Drives

a) TDBFP

Each TDBFP shall be provided with a variable speed turbine drive. Main pump shall be connected to the turbine through a disconnect coupling and booster pump shall be connected at other end of turbine through a gear box.

b) MDBFP

MDBFP shall be provided with a constant speed squirrel cage induction motor. The main pump shall be connected to the motor through a combined gear box cum hydraulic coupling and booster pump shall be connected at other end of the motor.

ii) Construction requirements

a) Main pumps

The main pump shall be of horizontal, centrifugal type, multistage, outer casing barrel type with end rotor removal.

b) Booster pumps

The booster pump shall be of single stage, two bearing design and double suction impeller type. Overhung type impeller shall not be acceptable.

iii) Suction and discharge connections

a) Main Pump

Location of suction and discharge connections of TDBFPs shall be on the bottom of barrel and those of MDBFP shall be on top of the barrel. Discharge connections shall be of butt welding type and suction connection shall be of either butt welding or flanged connection type.

b) Booster Pump

Side suction and discharge connections shall be of flanged type with weld neck raised face as per ANSI B16.5.

iv) Shaft sealing

Shaft sealing shall be achieved by mechanical seals both for main pump and booster pump.



v) NPSH margin

NPSH (R) at 3% head drop for booster pump as well as main pump shall be one third of NPSH (A) at design point with lowest deaerator level and maximum pressure drop across the strainer.

vi) Inter-stage bleed

Inter-stage bleed tap off for boiler reheater desuperheating shall preferably be taken from the lowest available intermediate stage pressure of main pump.

vii) Kicker stage (if required)

Spray water requirement of boiler superheater desuperheating shall be taken either from Kicker stage or any proven arrangement of bidder shall be acceptable subject to purchaser's approval. Kicker stage shall be capable for continuous operation with no flow to superheater desuperheating.

viii) Trip speed of TDBFP

Trip speed of TDBFP shall be 10% above the design speed of the feed pump.

ix) Performance curve

The characteristic curves of all the pumps shall be identical and shall be of continuously rising type with decrease in flow. The shut off head of the pump shall be between 120 and 130% of TDH at rated condition.

x) Minimum recirculation

a) The minimum flow of the booster pump and main pump shall not be less than 25% of their respective design flow or on set recirculation (discharge/suction) whichever is higher.

b) ON-OFF type minimum recirculation valve shall be provided with valve body designed for 40% of design flow.

xi) Interchangeability

The boiler feed pumps, booster pumps, drive turbines, hydraulic coupling and major equipment shall be identical in design in order to provide complete interchangeability.

xii) Motor drive start-up time for MDBFP

Motor drive shall be able to accelerate the pump from standby condition to its rated pumping condition in less than 15 seconds after receipt of starting signal while operating either singly or in parallel with other operating pump. MDBFP and associated auxiliaries shall be designed for auto start-up on failure of running equipment/ auxiliaries.



xiii) MDBFP lube oil system

Common lubricating oil system shall be provided for BFP, booster pump, motor and hydraulic coupling complete with AC motor driven auxiliary oil pumps, two full capacity each of working oil coolers, lube oil coolers, oil filters, strainers. The system shall be provided with piping, valves, fitting, instruments etc. as required.

xiv) Shaft design

The pump shall have stiff shaft design and minimum internal clearances more than maximum static shaft deflection.

xv) Critical speed

The first critical speed in water shall be above the speed corresponding to turbine over speed trip condition and internal clearances being 150% of new clearance or 130% of design speed whichever is higher.

xvi) First stage impeller life

The wear life due to cavitation for first stage impeller shall not be less than 40,000 running hours.

xvii) Dry running

The pumps shall be capable of accepting complete loss of water due to incidents such as inadvertent complete closure of suction valve and brought down to rest in controlled manner from design condition with simultaneous closure of suction valve.

xviii) Clearance between impeller and casing

The clearances between periphery of impeller and casing of boiler feed pump shall not be less than 4% and 6% of impeller outer diameter for diffuser and volute type pumps respectively.

xix) Efficiency

Efficiency of the BFP shall not be considered more than 83% (hot) for the purpose of arriving at capacity of the drive.

xx) Suction specific speed

The suction specific speed of first stage impeller for main pump and booster pump shall not exceed 8000 US units and 9500 US units respectively based on 3% head break down.



xxi) TDH per stage

TDH per stage for the main pump shall not exceed 670 mwc.

xxii) Casing design pressure

Casing design pressure for TDBFP shall be TDH at minimum flow with pump operating at trip speed under lowest operating density plus maximum suction pressure at booster pump. For MDBFP, the casing design pressure shall be TDH at minimum flow with pump operating at maximum speed at 51.5 Hz under lowest operating density plus maximum suction pressure at booster pump.

xxiii) Brinell hardness

The Brinell hardness of casing wear rings shall be 50 points different from that of impeller wearing surfaces.

xxiv) Axial thrust

Balancing drum shall be designed to balance 95% of total pump axial thrust. Balancing disc shall not be acceptable.

xxv) Thrust bearings

Thrust bearings of booster pump and main pump shall be designed for two times the worst thrust under turbine on trip speed, pump at shut off head and internal clearances 200% of new clearance. Thrust bearing shall be suitable for reverse rotation.

xxvi) Base plate

TDBFP shall be provided with fabricated steel common base plate for drive turbine, gearbox and booster pump, and separate base plate for main pump. However, bidder can offer combined base plate for booster pump and gear box and separate base plates for drive turbine and main pump individually as per his standard practice.

MDBFP shall be provided with fabricated steel common base plate for booster pump, motor, hydraulic coupling and main pump.

The bed plates shall extend under all parts of the equipments from which oil or water may drip and shall have a raised lip with tapped drain connection with suitable grout holes.



xxvii) Materials

A) Main pumps

- a) Barrel : Forged carbon steel with austenitic stainless steel inlay in high velocity zones and sealing surface.
- b) Inner casing, impellers, stage pieces : 13% chromium steel casting
- c) Wear rings, balancing drum bush : 13% chromium steel with antigalling properties
- d) Balancing drum : Stainless steel
- e) Pump shaft : 13% chromium steel forging.
- f) Shaft sleeves : High alloy chromium or chromium nickel alloy steel.

B) Booster pumps

- a) Shaft, shaft sleeves and wearing rings : 13% chromium steel forging
- b) Casing : Cast steel

xxviii) Applicable Code

The pumps shall be designed as per latest edition of Hydraulic Institute Standards (HIS), USA.

3.11.3 Other Requirements

i) Availability/ reliability

The pumps shall be designed for the highest practicable degree of availability and reliability under all conditions of operation such as operation on turning gear during startup, maximum and minimum temperature of feed water encountered during operation, abnormal pressure decay in deaerator, sudden generator load throw off, frequency variations (47.5 Hz to 51.5 Hz), HP-LP bypass operation.

ii) Warm up arrangement

The pump shall be capable of starting from any conditions without having any external warm up facility.



iii) Parallel operation

Response and performance characteristics of MDBFP and TDBFP shall be such that while operating in parallel the difference in flow handled by them shall not be more than 5% of flow through any one pump.

iv) Emergency lubrication of MDBFP

Provision shall be made for pressure lubrication (if necessary) of MDBFP at the time of coasting down of the motor driven boiler feed pump in the event of AC power failure.

v) Maximum flow handling

If bidder foresees any possibility of the feed pump operating at flow beyond its maximum flow handling capability due to low system resistance, bidder shall make necessary arrangements to protect the pump from such high flow condition without any necessity of reducing the plant load.

vi) Cartridge concept

The inner pump elements comprising shaft, impellers, stage casings shall be capable of being removed and replaced as a unit without disturbing feed piping in not more than 12 hours and shall be demonstrated by bidder. Suction, discharge and interstage bleed connections should not require to be broken to dismantle the pump.

vii) Handling arrangement

TDBFPs and MDBFP shall be accessible to turbine hall EOT crane for their erection and maintenance. In case MDBFP and TDBFPs are not accessible by turbine hall EOT crane, separate adequate handling facilities shall be provided for these equipments subject to purchaser's approval.

3.11.4 Mechanical Seals

i) Type

Mechanical seals shall be of fully cartridgised design and shall have dry running withstand capability. The seal face materials shall not be inferior to a rotating silicon carbide and stationary carbon seal face combination.

ii) Life

Life of mechanical seals shall not be less than 20,000 running hours between overhauls.



iii) Supporting system

Each mechanical seal shall be provided with 2x100% magnetic filters, 2x100% tubular coolers, piping, valves, control and instrumentation etc. Coolers shall be designed with margin of 20% over worst condition of heat generated in seals. Further in case of AC power failure, seals should be able to withstand operation without cooling water.

3.11.5 Gear Boxes

i) Type

The gear boxes shall be of double helical type manufactured by hobbing process and shall be dynamically balanced. The high speed pinion shall be of heat treated forged steel with integral shaft and low speed gear shall be of forged steel keyed to the input shaft. The gear casing shall be horizontally split and accurately machined to provide oil tight joints. The gears shall be enclosed in an oil and dust proof gear casing made of grained cast iron or fabricated steel. Oil used shall be same as for the pump, motor and turbine and supplied from pump lubrication system. Gear boxes shall be designed for continuous service.

ii) Service factor

- a) TDBFP (gear box between turbine drive and booster pump) : 2.0
- b) MDBFP (combined gearing/hydraulic coupling) : 1.4

iii) Instrumentation

Gear box shall be provided with two oil level gauges, drain fill vent thermometer dipstick with approved mounting valves, fitting etc. on gear casing.

iv) Bearings

Gear box shall be provided with separate thrust bearings to meet worst duty conditions. Bearings shall be of split sleeve type bronze backed with a high grade centrifugally cast tin base babbitt lining. Gear journal bearing shall have babbitted thrust faces next to the gear to act as locating surfaces for the gear train.

v) Applicable code

Design and manufacturing of gear boxes shall be as per AGMA 420 and 421.

3.11.6 Hydraulic Coupling

i) Type

The hydraulic coupling shall be of combined gear box and fluid coupling type, and shall be provided with electric actuator, linkages and necessary amplifier units.

ii) Rating

The hydraulic coupling shall be adequately rated to meet the requirement of pump characteristics while operating in the range of capacities specified.

iii) Materials and other accessories

The hydraulic coupling shall be complete with stainless steel impellers, casing, self supported double duty roller bearings, pillow blocks and Kingsbury/ Mitchell thrust bearing or proven thrust bearing as per manufacturer's standard practice for inlet/outlet with removable covers, oil sump, duplex filters to remove all particles upto 5 microns, oil temperature and pressure gauges, control pump for oil regulation if provided, regulating valves, stainless steel scoop tube, 2x100% lube oil coolers, 2x100% working oil coolers, one portable type oil purifier of adequate capacity.

3.11.7 Other Couplings

Other couplings shall be of flexible metal diaphragm type designed to limit the rotor end play with spacer. However, bidder may offer flexible gear coupling between gear box and booster pump for TDBFP.

3.11.8 Oil Coolers

i) Type

Oil coolers shall be of shell and tube type. The tubes shall be roller expanded and flared at the ends and tube bundles shall be of removable type.

ii) Materials

Tubes shall be of SS 304 and shell construction shall be of carbon steel. Suitable corrosion allowance shall be provided for all carbon steel and iron parts including shell, flanges etc.

iii) Rating

Oil coolers shall be adequately rated with suitable fouling allowance in accordance with EMA with necessary arrangements for changing over the cooler without interrupting the oil flow.

iv) Cooling arrangement

Cooling medium shall be demineralized water taken from closed loop equipment cooling system. Cooling medium shall flow in tube side.

v) Instruments

Temperature and pressure indicators shall be provided on inlet and outlet branches of the water side and also on the shell side of each cooler. Adequate arrangement for draining and venting of all parts of cooler shall be provided.

3.11.9 Drive Turbine

3.11.9.1 Design and constructional features

i) Type

Drive turbine shall be of dual admission type or single admission type with an external control valve, single cylinder, condensing type.

ii) Casing

- a) The casing shall withstand the maximum pressure and temperature likely to be encountered during normal operation and 25% over rated pressure for short term duration.
- b) Casing shall have uniform shape and thickness, free from sharp corners and shall be symmetric design to maintain thermal balance.
- c) Provisions shall be made to take care of the effects of temperature changes on the alignment of the rotating parts relative to the casing and glands and free movement of casing due to expansion both longitudinal and transverse.
- d) Casing shall be horizontally split at the centre line for raising and lowering the upper halves and rotor to clear off remainder of machine. It shall permit inspection of the main bearings without dismantling the casing.
- e) Horizontal casing joint shall be made steam tight with metal to metal contact. Gasket or grooves shall not be acceptable.
- f) Horizontal joint bolts shall be heat tightened and necessary bolt heating equipment and accessories (if required) shall be provided by the bidder.
- g) Control valve chest shall be an integral part of the drive turbine.

iii) Rotor

- a) Rotor shall be of forged steel, heat treated, accurately machined and proportioned in order to keep critical speed away from operating speed.
- b) The rotor shall be dynamically balanced.



- c) Turbine blading shall be designed to have a high efficiency of energy conversion, consistent with low loading, stressing and vibration consideration to ensure high degree of availability.
 - d) All nozzles and blading in steam path shall be of corrosion and erosion resisting alloy steel suitable for temperature encountered.
 - e) Rotor blading shall be securely fixed and readily renewable type.
 - f) Turbine blading shall operate smoothly over the operating speed range. The natural and harmonic frequency of vibration of last few rows of blades shall be such that they are well outside the operating range so as to avoid resonant vibrations.
- iv) Stop and control valves
- a) Valves shall be arranged to close through a trip device actuated either by over speed governor or by action of other protective devices.
 - b) Stop valves shall be provided with removable stainless steel steam strainer for normal operation, and one extra strainer shall be provided for initial operation.
 - c) Valves shall be provided with removable internals to allow for steam blowing.
 - d) Valves shall be designed to resist erosion due to steam flow and to be stable and not to vibrate over entire operating range.
 - e) Control valves shall be designed to provide the required steam flow control when operating in conjunction with turbine governing system as specified elsewhere.
 - f) Control valves and their seats shall have stellite inlays with their stem hardened. Alternatively, nitriding of spindles and guide bushes shall also be acceptable as per standard practice of the manufacturer.
 - g) Stop valves shall have provision for on-load testing.
 - h) Inlet connections of control and stop valves shall be of flanged type.
- v) Bearings
- a) The bearing shall be designed to avoid oil whip. Bearings shall be spherically seated, horizontally divided type, with provision of adjustment and alignment of rotor, forced feed lubricated type, lined with babbitt or suitable anti-friction alloy. The thrust bearing shall be of proven design as per standard practice of the manufacturer.



- b) Bearings shall be arranged outside drive turbine so that these are readily accessible. Lower half of bearing shall be capable of being removed and replaced by minimum lifting of shaft.
- vi) Couplings
- a) The disconnect coupling shall automatically disconnect the pumps from the drive turbine so as to permit independent operation of turbine on turning gear. Alternatively, dry type flexible membrane coupling may also be provided between BFP and drive turbine to facilitate disengagement by dismantling of spacer bolts as per standard practice of the manufacturer.
- b) Other couplings shall be of flexible metal diaphragm type, requiring no oil lubrication from the external source. However, the coupling between gear box and drive turbine may be oil filled flexible type without requiring external oil supply. Closure plates shall be supplied to allow drive turbine to be disconnected for spin testing.
- vii) Turning gear
- a) Turbine shall be provided with an adequately sized AC motor driven or hydraulically operated turning gear for rotation of complete TDBFP train i.e. booster pump, gear box, drive turbine and main pump while unit being started or taken out of service.
- b) Turning gear shall be so arranged that drive gear is engaged manually by means of external lever while turbine is at rest. When steam is admitted to the turbine and its speed reaches beyond turning speed, its gear shall automatically disengage and latch in a disengaged position.
- c) Necessary interlock shall be provided to prevent the starting of turning gear motor and shall trip on loss of lube oil pressure and should have provision of starting from the control room.
- d) Hand barring gear shall be provided for manually rotating the drive turbine in an emergency. The lube oil shall be made available to the bearings during such operation.
- viii) Lubricating oil system
- a) Each drive turbine shall be provided with a complete lubricating oil system which shall provide lube oil for drive turbine, main pump, booster pump and disconnect coupling and also to cater the control oil of governing system and turning gear oil requirements. The lube oil system shall consist of:
- 2x100% AC motor driven oil pumps



- One no. DC motor driven emergency oil pump for bearings oil requirement only.
 - 2x100% capacity oil coolers
 - Oil reservoir with five minutes retention time
 - Duplex type full capacity oil filters of cartridge type with automatic bypass facility
 - One no. full capacity AC motor driven jacking oil pump (if required)
 - One no. oil conditioning system of centrifuge type as specified for main turbine
 - One no. portable type oil purifier per unit
 - 2x100% AC motor driven oil vapour exhausters
 - Other accessories to render the system complete.
- b) It is preferable to have quality of lube oil and working oil for MDBFP and TDBFP identical to that of main turbine lube oil quality.
- c) Suitably sized hydraulic accumulators shall be provided in governing oil system to maintain system pressure, when there is a change over from one running pump to stand by oil pump. Also provision shall be made for initial air purging of the governor system.
- ix) Turbine exhaust pipe
- Turbine exhaust shall be separately piped to the condenser of main TG unit in the downward direction.
- x) Codes
- Design of drive turbines shall be in accordance with API 612 and 614 except as modified herein and generally used in thermal power plants and testing in accordance with ASME-PTC6. However, ageing factor on BFP drive turbine shall be considered same as for main TG.
- xi) Blades tuning
- Turbine blades, in particular last stage blades shall be independently tuned to keep the blade resonant frequencies away from operating speed.

xii) Protection against water induction

Turbine shall be designed for protection against water induction. All drains shall consist of motorised drain valves with isolating valves and drain piping for connection to drain flash tank i.e. for warming up drains before and after valve seats, casing drains, gland steam system drain, IP extraction, CRH and auxiliary steam lines alongwith necessary controls.

xiii) Protection against erosion and corrosion

Last stage blading of turbine shall be designed for protection against erosion and corrosion by moisture.

xiv) Governing system

Turbines shall be designed for electro-hydraulic or electronic control system to control speed from 0% to 100%. It shall be of the type which provides continuous corrective action until equilibrium conditions are obtained in response to changes in external signals or speed change resulting from other causes, such as changes in energy of the steam available to a turbine during sudden load pick ups or rejection on the main turbine generator unit. The system shall ensure controlled accelerating of the drive turbine and shall prevent over speed without tripping of the equipment under any operating condition or in the event of maximum load rejection.

3.11.9.2 Source of steam for TD-BFP

- i) During low unit load conditions, turbine bypass operation, shutdown operation when extraction steam pressure from IP turbine is insufficient to operate the drive turbine, steam from alternate source i.e. cold reheat steam shall be admitted through a separate set of stop and control valves. Both sets of control valves shall be controlled by electro-hydraulic governing system. Bidder can offer single admission turbine with an external control valve (to be operated from the same governing system).
- ii) During cold/warm/hot start of boiler, TDBFP can be started with auxiliary steam (in case MDBFP is inoperative) till motive steam from CRH is available.
- iii) All other auxiliaries shall be designed for auto start of standby equipment on tripping of running auxiliaries.

3.11.10 Suction Strainers

Strainer shall be provided at suction of each boiler feed pump and its booster pump. The details and requirements of the strainers shall as per clause 3.9.4.3 of this Section.



3.12 CONDENSATE POLISHING UNIT (CPU)

The bidder shall supply complete system including common regeneration facility as per his standard design and as elaborated in these specifications for treating the condensate.

3.12.1 Salient Design Data

- i) There shall be 3x50% capacity service vessels per unit designed as per condensate flow corresponding to maximum TG output at 3% make up, 89 mm Hg (abs)¹⁸ back pressure and all HP heaters out of service.
- ii) The quality of influent (condensate at inlet of CPU), effluent (condensate at outlet of CPU) and service run length to be considered for design of the CPU shall be as below:
 - a) Normal conditions:

During normal conditions, the quality of influent and effluent shall be considered as below:

<u>Description</u>	<u>Influent</u>	<u>Effluent</u>
Sodium, ppb	10	2
Iron, ppb	50	5
Silica, ppb	30	5
Chloride, ppb	10	2
Ammonia, ppb	500	-
TDS (total dissolved solids), ppb (excluding ammonia)	100	25
pH	9.2	-
Conductivity, μ mhos/cm	0.3	≤ 0.1 at 25 ⁰ C
Suspended solids (crud), ppb	50	5

Under the above operating conditions and design flow through the polisher units, the service run of the vessels shall be minimum 15 days (360 hrs). The mode of CPU operation during this period shall be either in hydrogen cycle or a combination of hydrogen and ammonia cycle which shall be decided by the bidder while maintaining the above effluent quality.

¹⁸ 70 mm Hg (abs) for sea water based once through CW system



Bidder shall declare in his bid the number of days of operation in hydrogen cycle and ammonia cycle (if opted by the bidder) separately in a cycle of 15 days. Whenever specific conductivity starts increasing in the effluent, it shall be deemed that the ammonia cycle has commenced.

b) Start up conditions

During unit start- up conditions, the quality of influent shall be considered as below:

TDS, ppb	2000
Silica, ppb	150
Crud (mostly black oxide of iron), ppb	1000

For design purposes, average crud loading shall be considered as 500 ppb.

For the above influent parameters, total crud content of the effluent shall not exceed 150 ppb.

The useful service run between two regenerations under start- up conditions shall not be less than 50 hours.

c) Condenser tube-leakage condition:

For condenser tube-leakage condition, the CPU shall be designed for TDS of 2000 ppb in addition to the normal influent contaminants stated at (a) above. The analysis of cation and anion in 2000 ppb TDS shall be based on the circulating water analysis.

Under condenser tube-leakage condition, the sodium content of the effluent shall be limited to 20 ppb maximum.

The useful service run between two regenerations under condenser tube-leakage condition shall not be less than 50 hours.

- iii) The bed cross section shall be such that the average velocity of condensate through it shall not exceed 2 meters/min at the design flow rate. The effective depth of the mixed resin bed in the condensate polisher service vessels shall not be less than 1100 mm.
- iv) Maximum pressure drop under dirty conditions will be restricted to about 3.5 kg/cm² including the pressure drop across effluent resin traps.
- v) Cation resins shall be regenerated by technical grade hydrochloric acid to IS:265 (concentration 30-33% by volume) and anion resins by sodium hydroxide, rayon grade to IS:252 available as 48% lye or as flakes.



- vi) The regeneration process offered by the bidder shall be of proven design and shall give resin separation compatible with the desired effluent quality. The bidder shall include inert resin in the system if he feels that it helps in better resin separation.
- vii) Bidder shall submit sizing calculations for resin volume provided and capacities of various regeneration equipment and neutralizing pit during detailed engineering.

3.12.2 System Requirements

- i) Service vessels
 - a) Service vessels shall be complete with condensate inlet and outlet connections, connections for resin transfer to and from the vessels, bed support-cum-underdrain system, inlet water distributors, air distribution arrangement for resin mixing, all fittings and appurtenances etc. as specified and as required.
 - b) Inlet water and regenerant distributor of service vessels shall be of hub and diffuser splash plate or header and perforated laterals. Material of construction shall be SS-316 except for acid service which will be of hastelloy- B.
 - c) Under drains shall be provided with screened laterals with internal perforated pipes and rubber lined flat bottom. For resin separation/ regeneration/ mixed resin vessels, it may have fully screened bottom (NEVA - clog type with pora septanurese screen, fully supported by subway grid or equal).
 - d) All internal fasteners shall be of SS-316 and heavy duty locknuts shall be used throughout.
 - e) External resin traps shall be provided at the outlet of each service vessel, designed for in-place manual back washing.
 - f) All necessary valves and fittings with actuators necessary for their remote operation.
 - g) A common drain header shall be provided for the service vessels of each unit.
 - h) All necessary drains, vents and sampling points, with valves shall be provided as required.



ii) Exchange resins

- a) Cation-anion resin ratio shall be 1.5 parts cation to 1.0 part anion by volume. In case the bidder's process require any non ionic resin the same shall represent at least 10 percent of the bed volume, but not less than 15 cm of the bed depth in the resin separation/cation regeneration tank of the external regeneration facility.
- b) The bidder shall include with the plant adequate resins for the condensate polisher service vessels along with one (1) spare charge of resin in the mixed resin storage tank. In addition a separate charge of resin shall also be included for using the resins during commissioning of unit.
- c) The resins shall be in the form of spherical beads. The particle sizes and densities shall be carefully selected to facilitate clear separation between the resins during regeneration process.
- d) The average force required to fracture the individual bead of cation resin in hydrogen form, anion resin in hydroxide form and Inert resin shall exceed 350 grams. Not more than 5 percent of the beads tested in each batch shall get fractured by forces less than 200 grams.
- e) Base of the ion-exchange resins shall be copolymer of styrene and divinylbenzene forming a macroporous or macroreticular structure. The type of resins to be supplied shall as below:

Cation : Strong acid, with sulfonic acid functional group

Anion : Strong base, with quaternary ammonium (type- I) functional group

Inert : Non ionic, compatible with the above type resins
- f) The resins shall be of reputed manufacturer with adequate past record of successful service for not less than 3 years in similar application.

iii) Vessel freeboard requirements

The pressure vessels in the common external regeneration facility shall be provided with adequate freeboards over the top of the settled resins, to minimize resin loss during their use. Minimum permissible freeboards are as follows:

- Mixed resin storage vessel - 50%
- Resin separation vessel - 75%
- Anion and cation regeneration vessels- 100%
- Activated carbon filter- 75%

In case resin separation vessel is also used as regeneration vessel then the free board shall be 100%.



- iv) Design and construction requirement
- a) Design pressure of service vessels shall be equal to shut off pressure of condensate extractions pump + 5% margin. For all other pressure vessels the design pressure shall be atleast $8 \text{ kg/cm}^2 \text{ (g)}$.
 - b) Design temperature of the vessel shall take care of all operating regimes including HP-LP bypass operation.
 - c) All pressure vessels shall be designed and constructed in strict accordance with the ASME code Section- VIII or acceptable equivalent international standard. Suitable mill tolerances shall be considered for determining the thickness of the shells and dished ends. A minimum thinning allowance of 2 mm shall be considered for the dished ends.
 - d) All service vessels and regeneration area pressure vessels shall be fabricated from carbon steel plates to SA 285C or SA-516 Gr. 70 or equivalent and lined internally. Conical or flat end service vessels shall not be accepted.
 - e) Lining used may be soft rubber having a shore durometer reading of 40-70 on the A scale, or semihard rubber having a durometer reading of 45-70 on the D scale. The lining shall be applied in three layers, resulting in a total thickness of not less than 4.5 mm anywhere on the internal surfaces of the vessels.
- v) Resin traps
- Outlet of each condensate polisher vessel, activated carbon filter and waste effluent header of the common regeneration shall be provided with a resin trap. Pressure drop at design flow through a clean resin trap shall not exceed 0.35 kg/cm^2 . Resin trap shall be of rubber lined steel construction and internals (cord and screen) shall be of Johnson Screens (Ireland) or equivalent (SS-316) construction.
- vi) Emergency bypass system
- a) Each condensate polisher service unit shall be provided with an automatic bypass for the condensate polisher on the condensate inlet and outlet headers of the unit with a butterfly type control valve and wafer type butterfly isolation valves on the upstream and down stream sides of the control valve. In the event of excessive pressure differential between the condensate inlet and outlet headers, this control valve will open automatically to bypass requisite quantity of condensate to prevent this pressure differential from exceeding a preset limit. The control system shall be so designed that the control valve is able to bypass 50% of rated flow when any of the service vessel is out of service and 100% of flow when both the service vessels are out of service.

- b) Complete instrumentation and controls for this system, including the differential pressure transmitters, panel mounted indicating type controller with provision for remote manual operation, actuator for the control valve with position indicator etc.
- vii) Piping
- a) Bidder shall design, supply and erect the piping between the service units and the common external regeneration facility, for transferring the exhausted and regenerated resins as required. Routing of this pipe line shall be developed by the bidder in line with his standard practice and shall be finalised in coordination with the Purchaser.
 - b) The arrangement shall avoid any sharp bends which cause segregation of the mixed resins, and pockets where the resins can get trapped. Suitable observation ports shall be provided in all critical areas to enable the operator to monitor completeness of the resin transfer operations. All necessary arrangements for venting and draining of the pipeline shall be provided.
 - c) Remotely operated valves suitably interlocked with the plant operation, shall ensure that the resins get transferred to and from only the particular service vessel which has been selected by the operator.
 - d) The resin transfer pipeline shall be of stainless steel type 304. The pipeline shall be sized for a flow velocity of between 2 and 3 m/s. The isolation valves on the resin transfer line shall be of eccentric plug type/ball valve of stainless steel construction.

3.12.3 External Regeneration Facility

One (1) common facility for regeneration of the ion-exchange resins from the condensate polishers of two units shall be provided. The system shall include but not limited to the following:

- i) Regeneration system
 - a) Two nos. resin separation/ regeneration vessels, one no. mixed resin vessel and one no. mixed resin storage vessel (to hold charge of one service vessel) shall be provided alongwith all internals, fittings and appurtenances for these vessels.
 - b) Resin injection hopper, complete with a water ejector system shall be provided for resin make-up to the resin separation/ regeneration vessel. The system shall be sized to handle upto 150 liters of as received new resins per single injection.



- c) All necessary piping, valves and fittings with the actuators necessary for their remote automatic operation shall be provided. These shall include all drains, vents and sampling points with valves as required.
 - d) Common waste effluent header with one resin trap designed for in-place manual backwashing shall be provided.
 - e) 2x100% capacity DM water pumps shall be provided for water supply for chemical preparation/dosing and transfer of resin from service vessel to regenerating vessels and vice versa. The pumps shall be horizontal centrifugal type and conform to IS: 1520/IS: 5120 or equivalent without any negative tolerance. All wetted parts of the pump shall be of CF-8M.
- ii) Chemical dosing system

Complete facility for dosing of acid, alkali and ammonia (if applicable) shall be provided as per details given below:

- a) 2x100% capacity hydraulically operated ejectors or metering pumps shall be provided each for dosing of acid and alkali. Material of construction shall be suitable for liquid being handled.
- b) Acid ejectors shall take suction from 2x100% acid measuring tanks and alkali ejectors from 2x100% alkali day tanks. Alkali day tanks shall be complete with carbon dioxide absorber and overflow seal. The capacity of tanks shall be atleast 20% higher than that required from process calculations.
- c) For heating of alkali diluent water, 2x50% electrical heating coil in a MSRL tank shall be provided. The capacity of tank shall be minimum 20% higher than the maximum water demand. This tank shall be provided with burn out protection, pressure relief valve, level switches, temperature indicator etc. The heater shall be controlled by the temperature switches provided on the tank. The heaters shall be sized for heating the water from a temperature of 15 to 50⁰C at the outlet of ejector. The water shall be heated to the required temperature within 5 hours.
- d) All interconnecting piping, valves and fittings as required for the system.
- e) Complete system for off-stream ammoniation of the resins, using ammonium hydroxide, shall be included in the offer, if felt necessary by the bidder to meet the system requirements. The system, if offered, shall include two (2) nos. bulk ammonia storage tanks (total one month storage), two (2) nos. motor-driven feed and recirculation pumps (each with 100% capacity), regenerant dilution tank, instrumentation and controls and all other appurtenances mounted on a separate structural steel skid.



iii) Alkali solution preparation facility

Complete facility for preparing alkali solution from alkali flakes shall be provided as per details given below:

- a) One (1) no. alkali preparation tank complete with electrically driven stirrer, and dissolving basket shall be provided. The tank capacity shall be equal to 120% of regeneration requirement of one polisher vessel.
- b) 2x100% capacity horizontal centrifugal type alkali solution transfer-cum-recirculation pumps shall be provided to fill the alkali day tank in one hour.
- c) One (1) no. activated carbon filter shall be provided for alkali preparation. The rated flow of the filter shall not be less than the design capacity of the alkali transfer-cum recirculation pump, and the maximum velocity through the filter shall not exceed 12 m/hr. Depth of the filter material shall not be less than 1 m.
- d) The prepared alkali shall be stored in two (2) no. alkali day tanks.
- e) Facility of bulk storage tanks to hold 48% alkali lye shall also be provided and alkali dosing system shall be designed for this also.
- f) All interconnecting piping, valves and fittings as required for the system.

iv) Materials

All the equipment viz. tanks, valves, piping, resin trap etc handling acid, alkali, DM water etc. shall be of MSRL construction, Valves for handling acid, alkali, ammonia, etc shall be preferably of diaphragm type (MSRL).

v) Air blowers

2x100% capacity air blowers (1W+1S) shall be provided for subsequent mixing of the resins. Further 2x100% capacity air blowers shall also be supplied for mixing the resins in the service vessels. Each blower shall be complete with motor, V-belt drive with belt guard, inlet filter/silencer, flexible couplings and discharge snubber, all mounted on a single base. Relief valve (s) shall be provided as required.

vi) Bulk acid and alkali storage tanks

These tanks shall be horizontal, dished ends, cylindrical type as per BS-2594 or equivalent and shall be located outdoor near the regeneration plant. These tanks shall be made of mild steel as per relevant codes. The inside surface of tanks shall be rubber lined (4.5 mm thick) and the out side surface shall be applied with chlorinated rubber paint. Vessels should be complete with vent, overflow, sample connection, manhole, stair case, platform, level indicator, fume absorber, CO₂



absorber, overflow seal pit etc. Specification of tank and pump shall be as below:

- Acid storage tanks : 2 Nos., 15 m³ each.
- Alkali storage tanks : 2 Nos., 15 m³ each.
- Acid unloading pump (Hastealloy-B construction for wetted parts) : 2x100%, 10 m³/h each
- Alkali unloading pumps (SS-316 construction) : 2x100%, 10 m³/h each

Required number of hoses shall be provided to receive acid and from road tankers.

vii) DM regeneration water tanks

Two nos. DM regeneration water tanks of MS rubber lined shall be supplied by bidder alongwith CO₂ absorber and over flow seal pit. The capacity of each tank shall meet the requirement of 1.5 times the DM water required for one regeneration including resin transfer operations subject to minimum capacity of m³. These tanks shall be filled by DM water cycle make-up system.

viii) Effluent disposal system

Neutralising pit shall be in two (2) sections of RCC construction and each section shall have a holding capacity of 1.5 times the waste effluent from each regeneration. Three (3) nos. Waste Recirculation / Disposal pumps of horizontal centrifugal type (Rubber lined) with priming arrangement shall be supplied for waste recirculation and disposal to the Purchaser's central monitoring basin. Each pump shall be designed to pump the, waste effluent of one regeneration in less than three (3) hours. Proven agitation system like air agitation, venturi mixing etc shall be provided in addition to recirculation from pumps.

Provision of dosing acid, alkali and lime shall be provided to neutralise effluents before disposal. All piping, valves etc. including lime solution preparation facilities shall be in bidders scope.

3.12.4 Control and Operation of Plant

i) General

The regeneration system shall be external and common to the two units. Under normal conditions, it will hold a complete charge of freshly regenerated and mixed resin, ready for use, in its storage tank. For regeneration, resin from the exhausted exchanger vessel will be transferred hydraulically to this facility. The empty exchanger vessel will then be filled up with the already regenerated resin



which was stored in the regeneration facility. This exchange vessel shall come into service soon after prerequisite condition is satisfied or as and when desired by the operator. In the meantime, the exhausted resin shall be cleaned, separated, regenerated, mixed and rinsed before being stored for next use.

- ii) Control and operation of the condensate polishing unit
 - a) The condensate polishing unit shall be controlled from the condensate polishing unit control panel, located near the polishing vessels. This panel shall be suitably interlocked with the regeneration system control panel.
 - b) It shall be possible to select each of the CPU vessels for any of the following operations:
 - Service
 - Resin transfer from CPU vessel to regeneration plant
 - Resin transfer from regeneration plant to CPU vessel
 - Isolation from service
 - Rinse recycle
 - c) A mimic diagram shall be provided for the CPU scheme on the front of the CPU control panel. Status of various valves shall be indicated by LED's on the mimic diagram.
- iii) Condensate polisher control system

Each condensate polishing system shall be provided with programmable logic control based local panel that will clearly show the status of each service vessel. From this panel it shall be possible to initiate any of the following operating modes:

- a) Rinse recycle

The rinse recycle shall be a manually initiated in full automatic sequence. This sequence shall include the rinse down step until the unit effluent quality is acceptable for boiler feed water. The effluent quality shall be determined by conductivity monitoring of the rinse water outlet. A panel mounted cation conductivity indicator shall be interlocked to prevent advancing of the automatic sequence until the rinse down is complete.

- b) Service mode

Service flow rate for each polishing vessel shall be monitored by panel mounted flow indicators. During periods of low condensate flow the operator may select to remove one of the vessels from service by a manually initiated automatic sequence. A differential pressure switch installed between the influent and effluent headers shall on a high signal cause an annunciator alarm.



Panel mounted cation conductivity indicators shall be provided to monitor the polishing system influent and effluent streams as well as the discharge of each service vessel.

- c) The sequence resin transfer from CPU vessel to regeneration plant and from regeneration plant to CPU vessel shall be initiated from the condensate polishing unit control panel but shall be controlled by the programmable logic controller in the regeneration control panel.
- iv) Regeneration control system
- a) Manually initiated automatic sequences shall be provided for transferring resin from a vessel to the remote common facility for physical cleaning and chemical regeneration and for returning fresh resin to that vessel. Control for chemical dosing system and alkali preparation facility shall also be provided in it.
- b) Regeneration shall include hydraulic reclassification of the resins and the transfer of the resins to the respective regeneration vessels. The separated resins shall then be backwashed, cation and anion regenerated with hydrochloric acid and sodium hydroxide solutions respectively, rinsed and then followed air scrubbing and a good backwash. The resin is then transferred back to the resin separation vessel and the resins are air mixed. The mixed resins after regeneration are given a final rinse with the discharge conductivity being monitored. If the quality is satisfactory, the mixed resin shall be transferred to the resin storage vessel otherwise regeneration sequence shall be repeated.
- c) Demineralized water shall be used throughout the regeneration process for backwashing, regenerant diluent, rinsing and resin transfer. A conical bottom hopper having a water ejector will be used for resin make-up.
- d) The complete control and operation of the regeneration plant shall be through programmable logic controller (PLC).
- e) It shall be possible to operate the regeneration plant in auto/semi-auto/manual mode.
- f) Following operations shall be possible from the regeneration control panel:
- Complete regeneration
 - Resin transfer from CPU vessel to regeneration plant.
 - Resin transfer from regeneration plant to CPU vessel.
- g) In 'Auto' mode, once the sequence has been initiated, it shall proceed from step to step automatically.
- h) In 'Semi-auto' mode each step shall be performed only after initiation by the operator.



- i) In 'Manual' mode complete operation shall be by the operator by operation of the control switches on the panel.
- j) On PLC failure, it shall be possible to operate the valves by means of manual operation of solenoid valves also.
- k) It shall be possible to switch mode of operation from one to the other at any moment and the operation shall proceed on the newly selected mode from that time.
- l) The system shall incorporate the necessary safety features. During automatic sequential operation, if any pre-requisite criteria is not fulfilled or missing for a pre determined time interval, the steps should not proceed further, and Alarm shall be provided. Missing criteria, sequence which is under hold up etc. shall be displayed on the panel.
- m) A mimic diagram of the Regeneration system shall be provided on the front of the panel. The status of various drives and valves shall be indicated by LED on the mimic diagram.
- n) Wherever standby equipments are provided, it shall be possible to select each of the drive on 'standby' duty.
- o) The detailed logic for the sequence and for each of the drive shall be subject to the Purchaser's approval.
- p) Start, progress and stop of each of the sequence shall be annunciated in all the control panels.
- q) At any time only one of the sequence shall be in progress.
- v) Interlocks

All interlocks for safe operation of the plant shall be provided. They shall specifically include the following as minimum requirement:

- a) Service vessels shall be taken back in service, only after they have been pressurized.
- b) Service vessels shall be taken up for resin transfer only after they have been completely isolated from the condensate system and depressurized.
- c) Resin shall be transferred to and from only one service vessel at a time.
- d) Resin transfer between the service and the regeneration skids shall be permitted only when the receiving vessel is initially empty.



- e) It shall be possible for the operator to extend the timing of a particular step by isolating the timer for the duration. The timer will restart once the operator puts back the system on 'auto' and the other steps will then follow as programmed.
- f) The regeneration sequence shall be prevented from advancing further in the event of tripping of a running motor or other fault condition which do not permit the various desired parameter of this step to be achieved. A manual override for this shall also be provided.
- g) The immersion heater in the hot water tank can be put on only when there is adequate water level in the tank.



STANDARD TECHNICAL SPECIFICATION FOR MAIN PLANT PACKAGE

SECTION- 4

(PIPING, VALVES, THERMAL INSULATION AND MISCELLANEOUS SYSTEMS/ EQUIPMENT)

4.1 HIGH PRESSURE / POWER CYCLE PIPING AND VALVES

4.1.1 General

- i) The design, engineering, erection, testing, etc. of the complete piping systems shall be to the requirements of power piping code ANSI B 31.1. In addition to this, requirements as laid down in Indian Boiler Regulations (latest edition) shall also be met completely.
- ii) All the piping systems and equipments supplied shall be designed to operate without replacement and with normal maintenance for a plant service life of 30 years and shall withstand the operating parameter fluctuations and cycling which can be normally expected during this period.
- iii) The design and engineering shall include, but not limited to, pipe sizing, flexibility and dynamic analysis, hangers, snubbers & support engineering etc. and shall be to purchaser's review and approval.
- iv) Steam blowing of piping systems after complete erection shall be carried out which shall include supply, erection and dismantling of temporary piping, valves and fittings.

4.1.2 Pipe Sizing

- i) Inside diameters of piping shall first be calculated for the flow requirement of various systems. The velocities for calculating the inside diameters are listed below:
 - a) Main steam, CRH & HRH : 76m/s (max.)
 - b) Auxiliary steam : 40- 50 m/s
 - c) Feed water suction : 2.0-3.0 m/s
 - d) Feed water discharge : 4.0-6.0 m/s
 - e) HP bypass upstream : 76 m/s (max.)
 - f) HP bypass downstream : 100 m/s (max.)



- g) LP bypass : 76-100 m/s
 - h) Extraction steam : 60 m/s (max.)
(Super heated)
 - i) Condensate suction : 1.5 m/s (max.)
 - j) Condensate discharge : 3.0-5.0 m/s
 - k) Other pipings : As per good engg. practice
- ii) Pipes shall be sized for the worst operating conditions (i.e. maximum flow, temperature and pressure values). In case of BFP suction sizing, transient analysis shall be carried out for optimum sizing of the system in order to establish the pipe inside diameter for minimum pressure drop in system to match with the pump NPSH requirement under worst operating conditions.

4.1.3 Material Selection

Piping system generally shall be of carbon steel for design temperature upto 400⁰C and alloy steel materials P11/P22/P91 for design temperature from 400 to 550⁰C and P91/stainless steel above 550⁰C.

4.1.4 Pipe Wall Thickness

Thickness calculation shall be made on the basis of procedure and formula given in ANSI B 31.1. Stress values of piping material for calculation shall be selected from tables given in ANSI B 31.1. Thickness, thus calculated shall be checked as per IBR formula (where applicable) and the more stringent of the two shall then be selected. In any case the thickness selected shall not be less than the standard thickness specified in ANSI B 36.10. In such cases where thickness calculated does not fall in the standard range of thickness as given in ANSI B 36.10, ID/OD controlled pipes as per ASA-530 shall also be acceptable.

However, the minimum selected pipe thickness shall be corresponding to Sch.-80 for pipe sizes 50 NB & below. For 300 NB & above, minimum pipe thickness shall be corresponding to Sch.- STD.

4.1.5 Layout

- i) All high points in piping system shall be provided with vents. All low points shall be provided with drains. Provisions of drains on steam piping shall be as per ASME code TDP-1. Drain lines shall be adequately sized so as to clear condensate in the line and prevent water hammer and damage to turbine due to water induction. All piping shall be sloped towards the system low point such that slope is maintained in both hot and cold condition. All drains and vent lines in piping system with design pressure 40 kg/cm² and above shall have two valves in series.



- ii) The pipe routing shall be such that a clear head room of not less than 2.5 metres above the walkways/working area is available. The contractor shall ensure correct orientation of and easy access to valves and instruments etc. and sufficient clearance for removal and maintenance of the same. The piping shall not encroach on withdrawal space of various equipments and walking space.

4.1.6 Stress/Dynamic Analysis

- i) Flexibility and stress analysis for various piping systems shall be carried out by the contractor as per the requirement of ANSI B 31.1. Analysis results shall satisfy the following:
- a) Calculated stresses shall be within the allowable limits stipulated in ANSI B 31.1 and IBR.
 - b) Calculated forces and moments on equipment nozzles shall not be more than the allowable loading provided by equipment manufacturer(s). Flexibility analysis shall also calculate the deflections in all directions (translational and rotational) to enable design and selection of hanger/support system.
 - c) Besides the flexibility analysis, steam hammer analysis/ dynamic analysis shall also to be performed wherever required to study the effects of fast closure of steam admission valves and safety valve blowing. Requirements of additional restraints/ snubbers to take care of these effects shall be established, and the contractor shall provide such restraints/ snubbers. The contractors shall also analyze the effects of seismic and wind loads and provide adequate support to take care of the same.
- ii) Cold pulling is not permitted. The contractor shall so design the piping systems that there will be no requirement of cold pull for meeting allowable reaction/stress values.

4.1.7 Piping

- i) Manufacturing tolerances on pipe diameter and thickness shall be as follows:
- a) ID controlled pipes:
 - Inside diameter : +0.0, - 1.6 mm
 - Thickness : -0.0, + 3.2 mm
 - b) OD controlled pipes
 - Outside diameter : -0.0, + 1.6 mm
 - Thickness : -0.0, + 3.2 mm
 - c) Other pipes : As per ASTM A-530



- ii) To account for losses due to corrosion, erosion etc. during the plant service life, an allowance of 1.6 mm shall be added to the minimum wall thickness of pipes.
- iii) Bend thinning allowance shall be provided for all bends as per the recommendations of ANSI B 31.1.
- iv) Steel pipes and fittings shall in general be provided with butt welding ends as per ANSI B 16.25. Pipe fittings of size 50 Nb and below shall be socket welded as per ANSI B 16.11. However, in certain cases the preparations of welding end for the pipe may be required to be done to match equipment terminals, valves etc.
- v) All stubs welded to the pipe including welded thermo-wells and instrument source tapings shall be installed on the pipe prior to stress relieving.
- vi) Instrument tubing upto and including the root valves and all line drains & vents shall be generally of the same pipe material as that of the main pipe on which they are located unless & until specified otherwise elsewhere.
- vii) Wherever ASTM A 106 Gr. B/Gr. C or A - 105 material are used the maximum carbon content shall be limited to 0.3% (Max.).
- viii) Wherever mitered bends are used the thickness of pipe from which they are fabricated shall conform to the requirements of IBR Regulations 361 (C). The angle between axes of adjoining pipe sections shall not exceed 22.5 deg.
- ix) Non-destructive examinations, as specified in Cl. 4.1.11 are for butt welds of NPS over 50 mm and for welded branch connections of branch size over 100 mm NPS. For smaller sizes, the mandatory minimum requirements shall be as per Table 136.4 of ANSI B 31.1 for non-IBR piping and as per Regulation 360 of IBR or table 136.4 of ANSI B 31.1, whichever is more stringent, for piping under purview of IBR.

4.1.8 Valves and Specialties

- i) For all globe and check valves, the direction of flow shall be clearly stamped on the body of the valve.
- ii) All globe valves shall be capable of being closed against the design pressure.
- iii) Where globe valve has been specified for regulation purpose, the disc shall be tapered plug type and suitable for controlling throughout its lift.
- iv) All gate and globe valves shall have bonnet-back seating arrangement to facilitate easy replacement of packing with the valves in service.
- v) All gate, globe and check valves shall be designed for reconditioning seating surfaces and replacement of stem and disc without removing the valve body from the line.



- vi) Manual gear operators shall be provided to open/close the valve against the maximum differential pressure across the valve such that the effort required to operate the valve does not exceed 25 kgf.
- vii) All valves of 50 mm NB and below with rising stem shall have visual indication through plastic stem covers. However, valves of 65 mm NB & above with rising stem visual indication either through plastic stem covers or through metallic stem covers shall be provided. All gate, and globe valves of size 50 mm and below in vacuum service shall have extra deep gland packing without requiring water gland sealing. All gate and globe valves of size 65 mm Nb and above in vacuum services shall have adequately deep gland packing and shall be equipped with lantern rings to admit pressurized water for gland sealing.
- viii) Where floors and extension spindle arrangements is required for valves, the height of floor stand shall be about one meter from the floor/platform. The floor stand shall be sturdy construction with column, nut plate and hand wheel made of the cast iron conforming to material ASTM-A-126 Grade B.
- ix) Integral bypass valves
 - (a) The requirement of integral bypass valves shall be worked out, as per process requirement, during detailed engineering.
 - (b) If integral bypass valve selected is of size 50 mm Nb and below, then gate or globe type of forged construction with socket weld end as per ANSI B-16.11 shall be provided. For integral bypass valves of size 65 mm Nb and above, only cast steel gate valves with butt weld ends as per ANSI B 16.25 shall be provided.
 - (c) Bypass pipe shall be of seamless construction and thickness corresponding to minimum of schedule 80 and shall be of the same material class as the main pipe.
 - (d) Integral bypass shall be motor operated if main valve is motor operated.
- x) All valves shall be provided with proper name plates indicating complete information about the valves.

4.1.9 Fabrication Requirements

- i) Piping system fabrication shall be in accordance with the requirement of ANSI B 31.1. However for system under purview of IBR, the requirements of IBR, shall also be complied with. All dissimilar material piping connections shall be subjected to the acceptance and approval of the Purchaser. The contractor in addition to the fulfillment of IBR requirement shall submit complete document.
- ii) Where welded pipe and fittings are used the longitudinal weld seams of adjoining sections shall be staggered by 90 deg.



- iii) While welding P1 materials to P5 materials (as identified in ASTM), suitable P4 materials shall be introduced in between.
- iv) Bends and elbows:
 - a) Elbows shall be generally of long radius type.
 - b) Bends for piping 65 mm Nb and above shall be made hot and for piping 50 mm Nb and smaller may be made cold.
 - c) Bends shall be made in accordance with PFI-ES-24.
 - d) Heat treatment of bends shall be done as per material specification and PFI-ES-6.
 - e) The finished bends wall thickness at any point of the bend shall not be less than the calculated minimum wall thickness. All bends 65 mm Nb and larger shall be ultrasonically examined as per PFI-ES-20.
 - f) Where examination of bends indicates that wall thinning has resulted in thickness less than the minimum specified, repair by weld deposition shall not be allowed.
 - g) Circumferential butt welds shall not be used in the area of the bend. Longitudinal welds, where bends are formed from welded pipe shall be located on the bend's neutral axis.
- v) Branch connections shall conform to the requirements of ANSI B 31.1. All branch connection welds shall be full penetration welds, except as permitted by ANSI B31.1/IBR.
- vi) All materials that are bent, forged or formed shall be subject to heat treatment after the forming operations as required by the original material specification. For alloy steel materials the preferred heat treatment process is full annealing.
- vii) Cleaning and protection:
 - a) Cleaning techniques shall be as per SSPC-SP-4.
 - b) After cleaning outside surface shall be coated with enamel or other protective paint. The weld end preparation shall be coated with deoxyaluminate paint and protected adequately. Use of grease or oil, other than light grade mineral oil is not allowed.
 - c) After descaling, the pipe shall be protected by applying internally with a water soluble preservative.
 - d) Following cleaning and preservation, the fabricated sections shall be covered, boxed, capped, or others shielded from further contamination or corrosion.



4.1.10 Erection Requirements

- i) Where control valves, flow nozzles, orifices and other piping appurtenances are to be installed, they shall be installed only after steam blowing and chemical cleaning operation. The contractor shall supply the pipeline without cutting it short. After the completion of the steam blowing/chemical cleaning the contractor shall cut spool pieces of required length and install the components as required to render the piping system complete.
- ii) The setting and logging of all supports, restraints, spring hangers, etc. is the responsibility of the contractor. The initial setting on all hangers and supports and clearance on restraints and limit stops shall correspond to the cold values. The Contractor shall check all readings after completion of welding, and application of insulation, and carry out readjustment as necessary. After satisfactory setting of all hangers, the load values, clearance etc. shall be logged clearly by the contractor in proper format and a joint protocol made.
- iii) The contractor shall monitor the behaviour of all hangers, supports, restraints etc. during the initial stages of plant operation. When the unit has attained its rated load and all piping system has attained its rated temperature the contractor shall log all load conditions, hangers and snubber deflections and clearances at restraints/limits stops.
- iv) The hydrostatic testing of the piping system shall be done after proper installation of all permanent hangers/supports. Spring hangers shall be locked during hydrostatic test. Prior to steam blowing all hangers which had been locked for the hydrostatic testing shall be unlocked.

4.1.11 Piping and Fittings

A. Pipes	<u>Alloy Steel</u>		<u>Carbon Steel</u>
	(1)*	(2)**	(3)***
1. System	Main steam, HP bypass	HRH, LP bypass and others Temp.>400°C	All other t<400°C
2. Material	ASTM-A-335-P-91	A335 P22 or A-335- P-91	A106Gr. B (Gr. C for BFD and CRH system) A672GrB60/70Cl 12/22
3. Construction	Seamless	Seamless	Seamless/ EFW
B. Fittings			
1. Material for connecting Nominal pipe size (NPS)			



Section- 4 (Piping, Valves, Thermal Insulation and Miscellaneous Systems/ Equipment)

a) 200 NB & above	ASTM A234 Gr. WP91	ASTM A234 Gr.P22 A 234 Gr.WP91	A234Gr. WPB/ Gr. WPC
b) 65 NB to 150 NB	ASTM A234 WP 22 OR ASTM 234 GR. WP91	ASTM A234 Gr.P22 ASTM 234 GR. WP91	A234 Gr. WPB/ Gr. WPC
c) 50 NB & below	ASTM A182 Gr. F22 or F91	ASTM A182 Gr. F22 or F91	ASTM A105
2. Basic standards	ANSI B16.9, B 16.11& B 16.25	ANSI B16.9, B16.11 and B 16.25	ANSI B16.25, B16.11 & B 16.9
3. Construction	Seamless (Forged for NPS 50 mm & below)	Seamless (Forged for NPS 50 mm & below)	Seamless (Forged for NPS 50 mm & below)
4. Rating/ wall thickness	----- To match with that of pipe -----		

C. Welding

Use of backing rings ----- Not permitted -----

D. Material analysis

1. Mandatory requirements	ASME for P-91	As per ASME B&PV Sect.-II	As per ASME B&PV Sect. II
2. Supplementary requirements		S1 and S2 for A335 P22 (one end on 5% of pipes per lot)	A106 Gr. C (one end on 5% of pipe per lot)
		S1, S2 & S4 for A234 WP 22	S2, S4 & S5 for ASTM A105
		S2, S3, S4 for A182 Gr. F22	S1, S2, S4 for A234 WPC

E. Non destructive examination (NDE)

1. Mandatory	-	100% UT & MPI, & 3% hardness testing on butt welds
--------------	---	--



2. Special requirement - As per ANSI B31.1 & Reg. 360
(d) of IBR
- 100% MPI for all welds.

F. Hydrostatic test pressure

1) Piping system under IBR purview:-

- At shop - All piping including fabricated piping shall be hydro-tested at 1.5 times the design pressure subject to regulation 374 of IBR.
- After erection - All piping systems shall be hydro tested at 1.5 times the design pressure subject to regulation 374 of IBR.

2) Non-IBR piping systems:-

- At shop - All piping including fabricated piping shall be hydro tested at 1.5 times the design pressure. However, the fabricated piping with NDE shall also be acceptable.
- After erection - All piping systems shall be hydro tested at 1.5 times the design pressure.

Notes:

- (1)* Applicable for MS&HP bypass line upto HP bypass valve. However, for piping 150 NB & below A335 P22 can be used but for temperatures above 550°C, the material shall be ASTM-A 335- P 91.
- (2)** Applicable for HRH, LP bypass and all other alloy steel piping.
- (3)*** Material A 672 Gr. 60/70 shall be applicable for 150 class EFW piping for sizes 550 NB and above. The fitting shall be fabricated from ASTM A 234 Gr. WPB to ANSI B 16.9.
- (4) Materials for fittings, specialities and valves shall be compatible with piping material.

4.1.12 Valves

- i) All valves shall be full port and shall meet the requirements of B 16.34. The valves shall be of reputed makes. The class of the valves shall be compatible to the service requirements.
- ii) Valves of size 65 NB and above shall have butt welded ends as per ANSI B16.25 and valves 50 NB and below shall have socket weld ends as per ANSI B16.11.
- iii) Locking arrangement, where specified shall be of non-detachable type.



- iv) Valves shall be tested in accordance to ANSI B 16.34.
- v) All gate and globe valves shall be with outside screw and yoke with rising stem. Globe valves shall be regulating type wherever the service intends so the material of body and trim shall be suitable to the class of valve.
- vi) Gate valves below 100 NB shall be solid wedge/flexible wedge type. Valves of class 150/ 300 and size 100 NB and above shall be of flexible wedge type. However, for sizes 100 mm NB and above for temperatures above 300 ⁰C, parallel slide valves are also acceptable.
- vii) Rubber lined valves shall have flanged ends as per ANSI B16.5.
- viii) Stem for all valves shall be heat treated and hardened - minimum, hardness 200 HB and surface finish of 16 RMS or better in area of stem packing.
- ix) Gland packing for gate and globe valves shall be alloy steel/ SS wire / Grafoil reinforced asbestos with stem corrosion inhibitor.
- x) All bolts and nuts for carbon steel valves shall be ASTM A-193 Gr. B 7 and ASTM A-194 Gr. 2H and for alloy steel valves shall be ASTM A-193 Gr B16 and A-194 Gr 4/7.
- xi) Hand wheels for valves shall be of carbon Steel or malleable iron.
- xii) Minimum differential hardness between seat and other disc material shall be 50 HB in case of 13% chrome hardened with heat treatment of steel.
- xiii) Valve closure test shall be as per ANSI B16.34 and MSS-SP-61. Acceptable seat leakage shall be 2 ml of water per hour per 25 mm of nominal pipe size.
- xiv) Safety and Relief valves shall be supplied complete with discharge elbow and drip pan along with drain.
- xv) For butterfly valves and all other valves of size 65 NB and above in vacuum service, water gland sealing arrangement shall be provided. For valves of size 50 NB and below, deep gland packing shall be provided. Butterfly valves, subjected to vacuum, shall be tested for vacuum as per relevant code.
- xvi) Specification for valve actuators shall be as indicated in relevant Sub-section.

4.1.13 Hangers and Supports

- i) All hangers and supports shall be erected such that they are vertical when the piping is in hot condition. However, in piping system connected to the turbine/turbine valve nozzles it may be required to erect the hangers/supports vertical in the cold condition or as per the recommendation of TG supplier to ensure that there is no transfer of undesired pipe weight/ load on the turbine valves/nozzles.



- ii) Design and Manufacture of hangers and supports shall conform to ANSI B 31.1, MSS-SP-58, MSS-SP-89.
- iii) Where hangers' rod angularity exceeds 4 degrees from cold to hot position, the hanger and structural attachments shall be offset in the cold position in such a manner that the hanger rod is vertical in hot position unless otherwise specified.
- iv) The Contractor shall furnish detailed arrangement sketches for each support, restraints, anchor, snubber etc in case of critical piping. The sketches shall include the key plan identification no., bill of quantities, design load, operating load, spring stiffness, amount of pre-compression, centre line elevation of pipe, spring box position/orientation, etc.
- v) Technical requirements
 - a) Each threaded connection and adjustable rod shall be with lock nuts.
 - b) Hanger support rods of less than 10 mm diameter for supporting pipes of 50 Nb and smaller and less than 13 mm diameter for supporting pipes of 65 mm Nb and larger, shall not be used.
 - c) Attachments to piping shall be by clamps/lugs. Bolted pipe clamps shall have a minimum thickness of 5 mm for weather protected locations and 6 mm for locations exposed to weather. Beam clamps shall be forged steel equipped with a rod to fix a nut.
 - d) All sliding surfaces of supports and restraints shall have teflon lining on one surface coming in contact with stainless steel lining on the other surface.
 - e) All pipes hangers and supports shall be designed to carry the weight of the piping fitting, thermal insulation, self weight of the hanger assembly and medium transported or test medium whichever is heavier. In addition, all rigid rod hangers and variable spring shall be designed to carry the operation load in hot condition.
- vi) Spring hangers
 - a) Constant load hangers shall generally be used when vertical displacement exceeds 40 mm or where the supporting effort variation of available variable spring exceeds 25%.
 - b) Constant load hanger shall be of moment-coil-spring counter balanced or cam and spring arrangement type design. Variable spring hangers shall be of helical spring design. Spring hanger/ assembly shall be constructed such that complete release of piping load is impossible in case of spring mis-alignment or failure.
 - c) Constant load hanger shall have a minimum field adjustment range of 15% of the load. The total travel for constant load hangers shall be design travel plus



20% but in no case shall the difference between total travel and design travel be less than 50 mm. The supporting effort variation throughout the travel range of constant load hangers shall not exceed 5%.

- d) Variable spring hangers shall have supporting effort variation of not more than 25% throughout the total travel range.
 - e) All springs shall remain under compression throughout their operating regime and never under tension.
 - f) Spring hangers shall have provision for locking the hangers in any position of the travel.
 - g) Spring hangers shall be adjusted to the cold position before shipment and locked in that position. The cold and hot position shall be clearly marked on the travel indicator scales.
 - h) All spring hangers shall be locked before performing the hydrotest. The locking shall be removed before the line is placed under operation.
- vii) Snubbers
- a) Snubbers shall be designed to allow normal movement of pipe due to thermal expansion and shall require minimal maintenance.
 - b) Axes of snubbers/ restraints shall be parallel to the direction of the expected reaction force in operating condition.
- viii) Restraints and anchors
- a) All anchors shall be designed for direct rigid fastening to the structural steel member.
 - b) Anchors, guides and restraints shall be capable of withstanding the forces and moments due to thermal expansion and dynamic effects.

4.1.14 Metallic Expansion Joints

- i) The expansion joints shall be of metallic multi-bellows construction and shall be used to reduce the reactions (forces and moments) at the connected equipment terminals due to thermal expansion/contraction and/or vibration of connected equipment and piping.
- ii) The design, material, construction, manufacture, inspection, testing and performance of the expansion joints shall comply with the currently applicable requirement of EJMA, Boiler and Pressure Vessel Code Section III, ANSI B-31.1 and all statutes, regulations and safety codes.



iii) Construction details

A) Bellows

- a) The bellow shall be hydraulically or roll formed from perfect cylinders of single ply, 304 grade SS.
- b) The number of longitudinal weld seams shall be minimum and there shall be no circumferential weld seam.
- c) Cold formed SS bellows shall not be heat treated.
- d) All bellow elements shall be pickled after forming.
- e) Equalising rings, where required, shall be either from high quality castings or from fabricated metal.
- f) Flanged expansion joints shall be provided with adequate pipe stubs.
- g) Butt welded expansion joints shall have adequate length of pipe so that site welding does not impair or reduce the joints efficiency.

B) Sleeves

- a) Expansion joints will be furnished with internal sleeves of the same material as the bellows and installed with sufficient clearance to allow full rated deflection. The sleeves shall be welded on the flow inlet end of the joint only.
- b) Bellow shall have external sleeves with an arrow indicating the direction of flow on the outside. The external steel covers provided to protect bellows from physical damages, shall be suitable for supporting insulation where necessary and shall be detachable.

C) Tie bars

- a) Joints shall be shipped at neutral length. They shall be provided with suitable erection and knock-off type temporary tie bars to prevent damage and misalignment during transit and also with permanent tie bars along with necessary nuts, bolts etc.
- b) The rods on pressure balanced type expansion joints shall be adequately sized to prevent buckling in vacuum services or services with other external loads.



4.1.15 Chemical Cleaning of Piping Systems and Equipments

- i) It is intended to chemically clean the following piping system:
- a) Boiler feed discharge piping
 - b) Heater drains piping
 - c) Main condensate piping
 - d) Extraction steam piping

The following equipments which form a part of the above system shall also be included in the cleaning operation.

- HP Heaters
 - LP Heaters
 - Deaerator
 - Gland steam condenser
 - Drain cooler
- ii) Before introducing chemicals, all the piping systems and equipment listed above shall be water flushed. Water flushing will be followed by alkaline cleaning, acid cleaning and passivation or by EDTA (Ethylene Diamene Tetra Acid) and passivation.
- iii) However, the Bidder shall submit alongwith the offer his usual procedures and practices for chemical cleaning of the piping and equipment specified. The Bidder shall submit all schematics, write up, details of chemicals to be used etc. and detailed procedures he intends to follow. These schematics and procedures shall be subject to the approval of the Purchaser.
- iv) Pre- cleaning procedure:

Prior to starting any phase of cleaning operation the following procedures shall be ensured:

- a) Installation of all temporary piping, valves, pumps and equipments as required for the flushing and chemical cleaning operations.

Temporary piping shall be routed at floor level as far as possible and secured in place to prevent movement/ vibration beyond acceptable limits.

- b) Installation of the instruments as required to ensure satisfactory monitoring and control of the cleaning process. The Contractor shall also determine and arrange locations for sampling of the cleaning solution during cleaning.



- c) Bypassing all regulation/control valves coming in the cleaning circuit or installation of temporary spool pieces.
- d) Installation of special end covers and temporary suction strainers, for boiler feed pumps and condensate pumps. Pump internals shall not be installed.
- e) Installation of plastic seal in the condenser neck to protect the turbine from alkaline fumes.
- f) Blocking and securing of all spring hangers in the steam lines which may be flooded during the cleaning operation.
- g) Hand cleaning of the interiors of all vessels which are included in the cleaning operation.
- v) General cleaning procedures:
 - a) Seal water lines to pump shall be flushed by the permanent arrangement provided for the same.
 - b) Where pipeline terminate in spray headers, these headers shall be inspected after each phase of the cleaning operation and cleaned if necessary.
 - c) All strainers shall be observed closely during the cleaning operation by reading differential pressure gauges, and shall be cleaned when the differential pressure exceeds a predetermined value.
 - d) All high points, vents shall be opened periodically to ensure full system flow.
 - e) Upon completion of each stage of cleaning, the waste products shall be drained and transferred to the waste treatment basins. The Contractor shall then supply and add the necessary chemicals to the basin to neutralise all waste solutions and rinses generated by the cleaning process, and arrange for its disposal to an area to be indicated by the Purchaser/Engineer.
 - f) Strict safety precautions shall be exercised at all times during the chemical cleaning and during storage and handling of the chemicals. The Contractor shall ensure provision of all protective clothing, apparatus and equipment alongwith necessary first aid kits as required for handling the chemical and for carrying out the cleaning operation.

4.1.16 Steam Blowing of Piping Systems

- i) Steam blowing shall include engineering, supply and installation of all temporary piping, valves, fittings including quick actuating valves (for puffing purposes), supports, blanking plates, spools, target plates, instruments, controls and all other accessories and services required to complete the cleaning process as specified herein.



- ii) The detailed schemes and procedure for steam blowing operations shall be prepared and furnished by the contractor and discussed and finalized during the detailed engineering stage.
- iii) Steam blowing shall also include reinstatement of cleaned piping systems; and dismantling/removal of all temporary piping, equipment and materials from site. All temporary piping, valves, equipment and materials shall be taken back by the contractor upon satisfactory completion of cleaning, and shall be removed from the Purchaser's premises.
- iv) Engineering involved regarding temporary piping shall include the following:
 - a) Selection of temporary piping including disturbance factor calculation.
 - b) Preparation of layout of temporary piping and performing stress analysis as per ANSI B 31.1.
 - c) Selection of temporary hangers and supports as required.
- v) The following piping systems shall be cleaned through steam blowing operation.
 - a) Main steam, HRH, CRH, HP bypass & LP bypass piping
 - b) Auxiliary steam piping including TG gland sealing lines.
 - c) Steam lines feeding turbines of boiler feed pumps
- vi) Steam blowing shall be carried out for removal of particles (rust, scales, weld splatter etc.) from various piping systems to avoid damage to turbine bladings. Cleanliness of system shall be checked by means of test plates made of steel, which will be installed in the centre line of the piping system.
- vii) Cleaning shall be achieved by steam purging i.e. by blowing of steam through the piping such that the momentum of flow is greater than that of steam flow during normal operation of unit (at TMCR). The disturbance factor during steam blowing (ratio of momentum of flow during purge to that during TMCR) shall be more than 1.4.
- viii) The blow off shall be done with steam, which is exhausted through adequately sized, open-ended temporary piping. Temporary piping and motor operated valves shall be installed for steam blowing operation. Pressure shall be built up in the boiler and the piping warmed before release of steam by quick opening of motor operated valve located on temporary piping. The cycle shall be repeated until steam from the blow out pipe is determined to be clean.
- ix) If the flow nozzles and control valves etc. have already been erected these shall be removed and replaced by spool pieces before steam blowing. The removed flow nozzle and control valves etc. shall be put back after steam blowing.



- x) The motor operated valves used for steam blowing shall have special characteristics like minimum loss of pressure, resistance to wear during severe working conditions (high velocity and carry over of water and solid particles), quick opening time, minimum effort on electric actuator etc.

- xi) The steam blowing termination criteria shall be as under:
 - a) Acceptable target plate condition
 - b) Measured disturbance factor (DF) more than 1.4

The required values to calculate actual DF will be measured at site. The criteria for acceptable target plate condition shall be finalised during detailed engineering.



4.2 CONTROL VALVES

4.2.1 General Requirements

- i) The control valves and accessories equipment furnished by the Bidder shall be designed, constructed and tested in accordance with the latest applicable requirements of code for pressure piping ANSI B 31.1, the ASME Boiler & pressure vessel code, Indian Boiler Regulation (IBR), ISA and other standards specified elsewhere as well as in accordance with all applicable requirements of the Federal Occupational Safety and Health Standards, USA or acceptable equal standards.
- ii) Bidder shall furnish all the control valves under this package as finalized during detailed engineering stage depending on the process requirements. All the control valves provided by the Bidder shall meet the specifications requirements specified herein.
- iii) The start-up system control valves and HP & LP bypass control valves shall be proven in same application and shall be as per Purchaser's approval.

4.2.2 Control Valve Sizing and Construction

- i) The design of all valve bodies shall meet the specification requirements and shall conform to the requirements of ANSI (USA) for dimensions, material thickness and material specification for their respective pressure classes.
- ii) The valve sizing shall be suitable for obtaining rated flow conditions with valve opening at approximately 80% of total valve stem travel and minimum flow conditions with valve stem travel not less than 10% of total valve stem travel. All the valves shall be capable of handling at least 120% of the required rated flow. Further, the valve stem travel range from minimum flow condition to rated flow condition shall not be less than 50% of the total valve stem travel. The sizing shall be in accordance with the latest edition of ISA on control valves. While deciding the size of valves, Bidder shall ensure that valves port outlet velocity does not exceed 8 m/sec for liquid services, 150 m/sec. for steam services and 50% of sonic velocity for flashing services. Bidder shall furnish the sizing calculations clearly indicating the outlet velocity achieved with the valve size selected by him as well as noise calculations, which will be subject to Purchaser's approval during detailed engineering.
- iii) Control valves of steam and water applications shall be designed to prevent cavitation, wire drawing, flashing on the downstream side of valve and downstream piping. Thus for cavitation/flashing service, only valve with anti cavitation trim shall be provided. Detailed calculations to establish whether cavitation will occur or not for any given application shall be furnished during detailed engineering stage.
- iv) Applications like the CEP minimum recirculation valve shall have anti-cavitation trim with tight shut-off. The deaerator level control valve shall have characterized trim cages to have a cavitation protection at minimum flow as well as good rangeability.



- v) All control valves shall have leakage rate as per leakage Class-IV.
- vi) The control valve induced noise shall be limited to 85 dBA at 1 meter from the valve surface under actual operating conditions. The noise abatement shall be achieved by valve body and trim design and not by use of silencers.

4.2.3 Valve Construction

- i) All valves shall be of globe body design & straightaway pattern with single or double port unless other wise specified or recommended by the manufacturer to be of angle body type. Rotary valve may alternatively be offered when pressure and pressure drops permit.
- ii) Valves with high lift cage guided plugs & quick change trims shall be supplied.
- iii) Cast iron valves are not acceptable.
- iv) Bonnet joints for all control valves shall be of the flanged and bolted type or other construction acceptable to the Purchaser. Bonnet joints of the internal threaded or union type will not be acceptable.
- v) Plug shall be one-piece construction either cast, forged or machined from solid bar stock. Plug shall be screwed and pinned to valve stems or shall be integral with the valve stems.
- vi) All valves connected to vacuum on down stream side shall be provided with packing suitable for vacuum applications (e.g. double vee type chevron packing).
- vii) Valve characteristic shall match with the process characteristics.
- viii) Extension bonnets shall be provided when the maximum temperature of flowing fluid is greater than 280 deg. C.
- ix) Flanged valves shall be rated at no less than ANSI press class of 300 lbs.

4.2.4 Valve Materials

The control valve body & trim material shall be generally as given below:

S. No.	Service	Body material	Trim material
1	Non-corrosive, non-flashing and non-cavitation service below 275 deg. C like Aux. steam flow to Deaerator, Condensate flow to Deaerator, CRH flow to Deaerator	Compatible with piping material	316 SS with stellite faced guide posts and bushings



2	Severe flashing/ cavitation services like HP heaters & LP heaters emergency drain, Deaerator overflow drain to hotwell etc.	Alloy steel as per ASTM-A 217 Gr.WC9	400 series SS or equivalent to suit the specific requirement
3	Low flashing/ cavitation service like HP heater/ LP heater normal drains level control, GSC minimum flow, gland seal steam pressure control valve etc.	Alloy steel as per ASTM A217 Gr. WC6	400 series SS or equivalent to suit the specific requirement
4	Condensate service below 300 deg. C like condensate normal and emergency make-up control, ECW DP control	316 SS	316 SS

Note : Valve body rating shall meet the process pressure and temperature requirement as per ANSI B16.34.

However, Bidder may offer valves with body and trim materials better than specified materials and in such cases Bidder shall furnish the comparison of properties including cavitation resistance, hardness, tensile strength, strain energy, corrosion resistance and erosion resistance etc. of the offered material vis-à-vis the specified material for Purchaser's consideration and approval.

4.2.5 End Preparation

Valve body ends shall be either butt welded/socket welded, flanged (Rubber lined for condensate service) or screwed as finalized during detailed engineering and as per Purchaser's approval. The welded ends wherever required shall be butt welded type as per ANSI B 16.25 for control valves of sizes 65 mm and above. For valves size 50 mm and below welded ends shall be socket welded as per ANSI B 16.11 Flanged ends wherever required shall be of ANSI pressure-temperature class equal to or greater than that of control valve body.

4.2.6 Valve Actuators

The HP and LP Bypass, turbine inlet control valves shall be with electro-hydraulic actuators and all other control valves shall be furnished with pneumatic actuators. The Bidder shall be responsible for proper selection and sizing of valve actuators in accordance with the pressure drop and maximum shut off pressure and leakage class requirements. The valve actuators shall be capable of operating at 60 deg. C continuously.

Valve actuators and stems shall be adequate to handle the unbalanced forces occurring under the specified flow conditions or the maximum differential pressure specified. An adequate allowance for stem force, at least 0.15 kg/sq.cm. per linear millimeter of seating surface, shall be provided in the selection of the actuator to ensure tight seating unless otherwise specified.

The travel time of the pneumatic actuators shall not exceed 10 seconds.



4.2.7 Control Valve Accessory Devices

- i) All pneumatic actuated control valve accessories such as air locks, handwheels/ hand-jacks, limit switches, pneumatic positioners, E/P Converters, diffusers, external volume chambers, position transmitters (capacitance or resistance type only), reversible pilot for positioners, tubing and air sets, solenoid valves and junction boxes etc. shall be provided as per the requirements.

- ii) Electric to pneumatic (E/P) converters:

E/P converters and associated accessories shall be furnished in accordance with the specifications given below:

- a) Air supply: 1.5 kg/cm sq., Input signal: 4-20mA DC (as required by the design of control system), Output signal: 0.2 to 1.0 kg/cm sq., Linearity: 0.5% of span or better, Hysteresis: 0.1% of span or better, Ambient temp. effect: less than 0.02% of span per deg C between -20 to +60 deg C. Mounting : Close to actuator (but not on the actuator), output capacity to suit the actuator, protection class IP-55.
- b) On loss of control signal, the last set point pressure shall be maintained so that the associated control valve remains in stayput position without using any solenoid valve. The allowable drift rate shall be $\pm 2\%$ of set point/hour maximum.

4.2.8 Tests

All valves shall be tested in accordance with the quality assurance programme agreed between the Purchaser and Contractor which shall meet the requirements of IBR and other applicable codes mentioned elsewhere in the specifications. The tests shall include but not be limited to the following:

- i) Non destructive test as per ANSI B-16.34
- ii) Hydrostatic shell test in accordance with ANSI B 16.34 prior to seat leakage test
- iii) Valve closure test and seat leakage test in accordance with ANSI- B 16.34 and as per the leakage class
- iv) Functional test: The fully assembled valves including actuators control devices and accessories shall be functionally tested to demonstrate times from open to close position.
- v) CV test: CV test shall be carried out as type test on each size, type and design of the valves as per ISA 75.02 standard and test report shall be furnished for Purchaser's approval.



4.3 EQUIPMENT COOLING WATER (ECW) SYSTEM

4.3.1 General

Closed circuit type ECW system shall be provided with demineralised (DM) water in the primary circuit and water tapped off from CW system upstream of condenser in the secondary circuit. ECW system shall be provided unit-wise and shall cater to cooling water requirements of TG and its auxiliaries as well as Steam Generator auxiliaries. Primary cooling circuits for auxiliaries of TG and SG packages shall be independent. The secondary cooling water circuit shall, however, be common for both the primary cooling systems.

4.3.2 System Design

- i) For primary circuit of TG auxiliaries of each unit, a set of demineralised cooling water (DMCW) pumps of 3 X 50% capacity shall discharge the cooling water through 3 X 50% capacity plate heat exchangers (PHE). For SG auxiliaries of each unit, 2x100% capacity DMCW pumps and 2x100 % capacity plate heat exchangers shall be provided.
- ii) The outlet header from plate heat exchangers shall be suitably branched off to supply the cooling water to the various auxiliary coolers. Outlet from the auxiliary coolers shall be connected back into a common return header and led back to the suction of DMCW pumps to complete the closed loop primary cooling circuit.
- iii) For both the primary cooling circuits of each unit, an overhead tank of minimum effective capacity of 10 m³ shall be provided with level control facility. The effective capacity of the tank shall correspond to 60% of the tank height. Outlet of this tank shall be connected to the closed circuit return headers of TG and SG auxiliaries cooling circuits to serve the following:
 - a) The expansion of closed cycle water due to temperature fluctuations and to control other transients.
 - b) For adequate Net Positive Suction Head (NPSH) for DMCW pumps.
 - c) For normal make-up to closed loop cycles.
 - d) Emergency water supply to critical coolers in case of power failure.
- iv) The pH of DM water in the closed loops shall be continuously monitored and controlled at around 9.5. The control shall be achieved by dosing sodium hydroxide in DM water overhead tank and primary side pipings for TG and SG auxiliaries. The NaOH solution shall be prepared in an overhead tank of adequate capacity, located above the elevation of ECW make up tank, and dosing shall be done under gravity by manually operating respective dosing valve. The material of construction of NaOH solution tank shall be mild steel rubber lined.



- v) The common secondary circulating water system shall operate in parallel to the condenser and shall receive water through a tapping on the CW inlet line to the main condenser. Pressure of this water shall be further boosted by a set of 3x50% capacity secondary cooling water (SCW) pumps and fed through the plate heat exchangers back to the CW discharge line of the main condenser.
- vi) To prevent fouling on the secondary circulating water side of the PHE, 2x100% capacity self cleaning type filters shall be provided on the circulating water inlet header to the PHE. The filter shall be provided with an automatic back-wash arrangement to facilitate cleaning of the choked filter while the pumps are in operation. Backwash shall be collected in a sump to be located in the main plant area. The collected backwash shall be pumped using 2x100% capacity sump pumps of adequate capacity such that the collected backwash can be removed in one shift of 8 hours. Backwashing shall be actuated and controlled either according to differential pressure and /or by timer.
- vii) The plate heat exchangers shall be designed with a terminal temperature difference (TTD) of 3°C (max.). The outlet temperature of cooling water on the secondary circuit shall in no case exceed the design outlet temperature of circulating water in the condenser.
- viii) Frame of each plate heat exchanger shall have about 25% extra capacity i.e. the frame shall be able to accommodate about 25% extra plates.
- ix) Make up to the closed loop primary circuit shall be taken from DM make up piping to the condenser. The make up would be given to overhead storage tank through a motorised valve interlocked to open/close automatically with level in the tank.
- x) A control valve shall be provided to maintain a constant pressure differential between the main supply and return headers of DM water. The valve will bypass flow to maintain a constant return header pressure to compensate for fluctuations in coolant flow to the process heat exchangers due to modulating control valves on the process coolers or if any cooler goes out of service in DM circuit.

4.3.3 Constructional Features

4.3.3.1 Pumps (primary side & secondary side)

- i) Type : Horizontal centrifugal type as per Hydraulic Institute Standards (HIS), USA
- ii) Casing : Axial split type.
- iii) Impeller type : Closed
- iv) Speed : 1500 rpm (max.)



Section- 4 (Piping, Valves, Thermal Insulation and Miscellaneous Systems/ Equipment)

- v) Drive transmission : Direct
- vi) Seal : Mechanical seal
- vii) Lubrication : Oil/ Grease/ Self liquid.
- viii) Coupling : Spacer type (as applicable).
- ix) Drain plug, vent, priming connection, coupling guard, lifting lugs, lifting arrangement (crane) : Required.
- x) Operating range : 40% to 120% of rated flow
- xi) Pump characteristic : Non overloading type & stable
- xii) Shut off head : At least 15% more than rated head.
- xiii) Parallel operation : Required (No damage should occur to any component due to flow reversal).
- xiv) Material of construction :

	Primary DM water cooling (DMCW) pumps	Secondary cooling water (SCW) pumps ¹	
		<u>For fresh water</u>	<u>For seawater</u>
a) Casing	ASTM-A-351 CF8M	2.5% Ni CI, IS 210 Gr FG 260	18% Ni CI ASTM A 439 type D ₂ /ASTM A 351 Gr CF8M
b) Impeller	-do-	Bronze to IS 318 Gr. I/II	ASTM A 351 Gr CF8M/Duplex SS
c) Wearing rings	SS-316	High leaded bronze to IS-318 Gr. V	Hardened duplex SS/ ASTM A 351 Gr CF8M/ SS 316 L
d) Shaft	SS-316	EN-8 (BS-970)	AISI 420
e) Shaft sleeve	SS-410	SS- 410	Duplex SS
f) Mechanical seal	-----	Manufacturer's standard	-----
g) Base plate	-----	MS fabricated IS-2062 with epoxy coating -----	

¹ Retain the details of fresh water or sea water as applicable



4.3.3.2 Heat exchangers

- i) Type : Plate type, single pass
- ii) Design pressure : 2 times working pressure or 1.5 times shut off head of respective pumps, whichever is higher.
- iii) Material of construction :
- | | <u>For fresh water</u> | <u>For seawater</u> |
|--|--|---------------------|
| a) Heat transfer plate | : SS-AISI-316 | Titanium |
| b) Compression/ fixed plates, movable pressure plate, support beam/ column | : ----- IS::2062 ----- | |
| c) Guide rail | : ----- IS-2062 with SS cladding ----- | |
| d) Plate gasket | : ----- Nitrile Rubber ----- | |
| e) Nozzle and flanges | : ----- Carbon steel ----- | |
| f) Nozzle flange gasket | : -- 3 mm wire inserted Red Rubber -- | |
| g) Nozzle flange bolts/ nuts | : ----- SA 193 B7/SA 194 2 H ----- | |
| h) Name plate | : ----- AISI-316 ----- | |
| i) Tightening rods | : ----- IS-1367 or equivalent ----- | |
- Double sealing arrangement should be provided at outer edge and around ports to avoid intermixing of fluids. The inter-space should be vented to atmosphere.
 - Plate thickness should be adequate to withstand all operating conditions but not less than 0.6 mm.
 - Frame of exchanger should be designed so that 25% additional plates can be added in future.
 - Flanges shall be per ANSI B 16.5 or equivalent.
 - Thickness of pressure and frame plates as per ASME sec. VIII Div. I.
 - Minimum corrosion allowance for heat exchanger parts shall be 1.6 mm.
 - After pressing all the plates shall be tested by light box/vacuum/air chamber test as per manufacturer's standard practice.



- The corrosion allowance for the heat exchanger parts such as pressure parts (support plates), nozzles, sliding channels and frame shall be 1.6mm (minimum).
- At least 10% plates shall also be randomly tested by dye-penetrant test.

4.3.3.3 Butterfly valves

- i) Standard for design : AWWA C-504 or BS 5155
- ii) Standard for testing : As per AWWA C-504
- iii) Design pressure : 2 times working pressure or 1.5 times shut off head of pump, whichever is higher.
- iv) Water application : Suitable for circulating water/ DM water application as required.
- v) Material of construction :

	Primary side	Secondary side ²
a) Body & disc	2% Ni-CI	CI to IS 210 FG-260/ ASTM A-216-CLB or fabricated steel as per ASTM A-515 Gr 60/ 80/ IS 2062/ IS 2002
b) Shaft	SS 410	AISI 410
c) Bearings	-----Self lubricating -----	
d) Seal	Buna- N	Buna- N
e) Retaining segment	SS-316	SS-316
f) Internal hardware	SS-316	SS-316
g) Companion flanges	---- IS-2062/ ASTM A 285 Gr. C -----	

4.3.3.4 Self cleaning filters

- a) Body of filter shall conform to carbon steel to IS 2062 or MSRL as applicable based on cooling water quality.
- b) Strainer element shall be constructed of perforated stainless steel plate lined with SS 316L/ SS316 screen as applicable based on cooling water quality.

² The material of construction of various components are given for fresh water. For sea water application these shall be of proven type as per the duty involved and subject to the approval of the purchaser



- c) The mesh size shall be selected on the basis of average clearance between the plates of the plate heat exchanger.

4.3.4 Sizing/ Design

4.3.4.1 Pumps

- i) Flow : Design flow of respective plate heat exchanger(s) +10% margin.
- ii) Head : As per system requirement +10% margin on friction head.
- iii) Motor Rating : Continuous motor rating (at 50⁰C ambient) for all pumps shall be at least 10% above the maximum power requirement at any condition of entire characteristic curve of the pump.

4.3.4.2 Plate type heat exchanger

- i) Design Secondary water inlet temperature : 36 deg. C
- ii) Secondary water outlet temperature : Not more than the design hot water temperature at condenser outlet.
- iii) Primary water outlet temperature : 39 deg C (maximum)
- iv) Overall fouling factor : 0.8×10^{-4} Hr m² deg C/ kcal
- v) Metallurgy : Suitable for circulating water and DM water application.

4.3.5 Overhead DM Make Up Tank

- i) Quantity per unit: : One
- ii) Size : Adequate (minimum 10m³ effective capacity)
- iii) Design Pressure : Atmospheric
- iv) Design Standard : ASME Boiler and PV code Section-VIII/ IS:2825 (Class 3)
- v) Material of Construction : Plates to IS:2062/ ASTM A36. Minimum shell thickness shall be 6mm.
- vi) Inside Protection : Rubber lining of 4.5 mm thickness



vii) External surface protection : Red lead primer with epoxy resin

All accessories such as vents, overflow and drain, CO₂ absorber for vent, seal for overflow, manhole & staircase, level indicator, level transmitter and level switch etc. shall be provided.

4.3.6 Instruments

- i) All instruments, such as thermo-wells, temperature elements, flow elements pressure & temperature gauges, DP switches, pH analyser, Rotameters etc. alongwith associated devices shall be provided.
- ii) Flow meter and manually operating globe/ regulating valves shall be provided on the water side of each cooler for control of DM water flow.



4.4 CHEMICAL DOSING SYSTEM

4.4.1 Low Pressure Chemical Dosing

- i) Arrangements shall be made to inject Ammonia and Hydrazine in the feed water suction lines to the boiler feed pumps as well as at the condensate pumps discharge after the condensate polishing unit. Ammonia shall be used as pH control agent and hydrazine as oxygen scavenger. The concentration of aqueous ammonia to be dosed shall be around 3% and that of hydrazine around 0.6%.
- ii) Each unit shall be provided with independent and skid mounted dosing system for Ammonia and Hydrazine dosing. Each chemical dosing skid shall consist of 1x100% capacity measuring tank, 2x100% capacity preparation/ storage tanks and 2x100% metering pumps complete with strainers, piping, valves, fittings, instrumentation and control panel etc. In addition, one bulk storage tank shall be provided for each unit for storage of concentrated aqueous ammonia. 2x100% capacity transfer pumps shall be provided for transfer of concentrated ammonia from bulk storage to the measuring tank. The ammonia transfer pumps shall be of centrifugal type. Hydrazine shall be received in small containers and hand pumps shall be provided for transfer of hydrazine to the measuring tank. The flow of chemical from measuring tank to the preparation/ storage tank shall be by gravity.
- iii) The bulk storage tank for ammonia shall be sized to hold one month requirement of aqueous ammonia. The measuring and preparation/storage tanks for each chemical shall be designed to have storage capacity equal to one day requirement of chemical dosing. Metering pumps for each chemical shall be of horizontal positive displacement, reciprocating and variable stroke type. All the chemical storage/handling tanks shall be of SS316. Transfer/ dosing pumps shall be of SS-304 construction. The tanks shall be complete with necessary fittings and accessories etc. including manhole/hinged cover, motorized stirrers for preparation tanks, drain connection, exhaust through water seal for ammonia vapours and level switches etc. The provision shall be made for flushing of the transfer/metering pumps by the condensate/DM water.

4.4.2 High Pressure Chemical Dosing (Phosphate Dosing)

4.4.2.1 Arrangements shall be made to inject sodium phosphate in the boiler water for water conditioning to suppress corrosion of the plant components/ material and to maintain the required water quality.

4.4.2.2 Each unit shall be provided with independent and skid mounted dosing system for sodium phosphate dosing. Each chemical dosing skid shall consist of 1x100% capacity measuring tank, 2x100% capacity preparation / storage tanks and 2x100% metering pumps complete with strainers, piping, valves, fittings, instrumentation and control panel etc. Adequate facilities shall be provided for transfer from storage tank/ container to the respective measuring tank. The flow of chemical from measuring tank to the preparation/ storage tank shall be by gravity.



4.4.2.3 The measuring and preparation/ storage tanks shall be designed to have a storage capacity equal to one day's requirement of chemical dosing. The transfer pumps shall be of centrifugal type and metering pumps shall be of horizontal positive displacement, reciprocating and variable stroke type. All the chemical storage/handling tanks and transfer/ dosing pumps shall be of SS-304 construction. The tanks shall be complete with necessary fittings and accessories etc. including manhole/hinged cover, motorized stirrers for preparation tanks, drain connection, exhaust and level switches etc. The provision shall be made for flushing of the transfer/metering pumps by the condensate/DM water.

4.4.3 Control and Instrumentation Requirements

- a) The bidder shall supply all necessary control and Instrumentation for satisfactory operation of chemical dosing system. All field instruments, devices as per the approved schemes shall be supplied.
- b) It is intended to control chemical dosing system from DDC MIS, including ON/OFF command of individual pumps. However bidder shall provide local pre-wired control panel complete with i) start/stop push buttons ii) indicating lamps iii) local/remote indication iv) stroke position indicator v) rise/lower push buttons for stroke position vi) local annunciations.



4.5 LOW PRESSURE PIPING, VALVES AND TANKS

4.5.1 LP Piping-General

- i) Sizing and system design of LP piping system, covered under this specification, shall conform to the requirements of relevant codes and standards. In addition to this, requirements of any statutory code as applicable shall also be taken into consideration.
- ii) Inside diameters of piping shall be calculated for the flow requirements of various systems. The velocities for calculating the inside diameters shall be limited to meet the following:

A) Water application

Application	Velocity in m/sec.
-------------	--------------------

- | | |
|----------------------------|-----|
| • Pump suction | 1.5 |
| • Pump discharge & Headers | 2.5 |

Pipe line under gravity flow shall be restricted to a flow velocity of 1 m/sec generally. Channels under gravity flow shall be sized for a maximum flow velocity of 0.6 m/sec.

WILLIAM & HAZEN formula shall be used for calculating the friction loss in piping systems with the following "C" value:

- | | | |
|-----------------------------|---|-----|
| a) Carbon steel pipe | : | 100 |
| b) C.I Pipe/ Ductile Iron | : | 100 |
| c) Rubber lined steel pipe | : | 120 |
| d) PVC/ HDPE/ GRP/FRP pipes | : | 140 |

For calculating the pump head, at least 10% margin shall be taken over the pipe friction losses and static head shall be calculated from the minimum water level of the tank/ sump/ reservoir from which the pumps draw water.

B) Compressed air application

Compressed air velocity : 15.0 m/sec.

- iii) The pipes shall be sized for the worst operating conditions. (i.e. maximum flow, temp. and pressure values)
- iv) Based on the inside diameter so established, thickness calculation shall be made as per ANSI B 31.1 and OD of pipes shall be selected as per standard range of manufacture.
- v) Corrosion allowance of 1.6 mm will be added to the calculated thickness being considered.



- vi) Bend thinning allowance/manufacturing allowance etc. shall be as per the requirement of the design code provision.
- vii) All high points in piping system shall be provided with vents alongwith valves. All low points shall be provided with drains alongwith valves. Material for drain and vent lines shall be compatible with that of the parent pipe material.
- viii) Compressed air pipe work shall be adequately drained to prevent internal moisture accumulation and moisture traps shall be provided at strategic locations in the piping systems.
- ix) Depending upon the size and system pressure, joints in compressed air pipe work shall be screwed or flanged. The flange shall be welded with the parent pipe at shop and shall be hot dip galvanized before dispatch to site.
- x) Threaded joints shall be provided with Teflon sealant tapes.
- xi) Following types of valves shall be used for the system/service marked as √.

System	Types of valves				
	Butterfly	Gate	Globe	Check	Ball
Water	√	√	√	√	√
Air		√	√	√	
Drains & vents		√	√	√	
Fuel oil (if any)		√	√	√	√

4.5.2 Pipes and Fittings

- i) All low pressure piping systems shall be capable of withstanding the maximum pressure in the corresponding lines at the relevant temperatures. The bidder shall furnish the pipe sizing/ thickness calculation based on system requirement.
- ii) Piping and fittings coming under the purview of IBR shall be designed satisfying the requirements of IBR as a minimum.
- iii) Supporting arrangement of piping systems shall be properly designed for systems where hydraulic shocks and pressure surges may arise in the system during operation. Bidder should provide necessary protective arrangement like anchor blocks/anchor bolts etc. for the safeguard of the piping systems under above mentioned conditions. The requirement will be, however, worked out by the contractor and he will submit the detailed drawings for thrust/anchor block to the Purchaser. External, and internal, attachments to piping shall be designed so as not to cause flattening of pipes and excessive localised bending stresses.
- iv) Bends, loops, off sets, expansion or flexible joints shall be used as required in order to prevent overstressing the piping system and to provide adequate flexibility.
- v) Wherever Bidder's piping coming under this specification, terminates at an equipment or terminal point not included in this specification, the reaction and the thermal movement imposed by bidder's piping on equipment terminal point shall be within limits to be approved by the Purchaser.



- vi) The hot lines shall be provided with spring supported hangers with flexible connections to permit axial and lateral movements. Flexibility analysis shall be carried out for pipelines which have considerable straight run and necessary loops/ expansion joint etc. shall be provided as may be necessary depending on layout.
- vii) Piping and fittings shall be manufactured by an approved manufacturer of repute. They should be truly cylindrical of clear internal diameter, of uniform thickness, smooth and strong, free from dents, cracks and holes and other defects.
- viii) For rubber lined ERW pipes, beads shall be removed.
- ix) For water pipes/ducts, air release valves shall be provided at highest point and bends/change of direction of flow. Sizing criteria for air release valves shall be generally on the basis of valve size to pipe diameter ratio of 1:8. Requirement shall be decided as per relevant code.

4.5.3 Material

- i) All materials shall be submitted with proper material test certificates.
- ii) Material test certificates shall carry proper heat number or other acceptable references to enable identification of the certificate that certifies the material.
- iii) Material of construction for pipes carrying various fluids shall be as follows:
 - a) Raw water, clarified water, service water and pH corrected DM water (CCW system) ASTMA-36/ASTM A-53 type 'E' Gr. B/ IS-3589 Gr. 410/ IS-1239 Heavy.
 - b) Sea water GRP/ FRP/ MSRL
 - c) Demineralised water Stainless steel ERW for sizes above 50 Nb. Seamless stainless steel to ASTM A312, Gr. 304 for sizes 50 Nb & below
 - d) Drinking water ASTM A-53 type E Gr. B galvanized/ IS 1239 heavy galvanised/ IS 3589 galvanised.
 - e) Instrument air & plant air. ASTM A-53 type E Gr. B galvanised/ IS 3589 Gr. 410 galvanised/IS 1239 heavy galvanised.
 - f) Oil piping API 5L Gr. B
- iv) Alternate materials offered by Bidder against those specified shall either be equal to or superior to those specified. The responsibility for establishing equality or superiority of the alternate materials offered rests entirely with the Bidder and any standard code required for establishing the same shall be in English language.



- v) In water lines, pipes upto 150mm Nb shall conform to ANSI B36.10 and minimum selected thickness shall not be less than IS:1239 Grade Heavy except for demineralised water, drinking water and condensate spill.
- vi) Pipes of above 150mm Nb shall conform to AWWA-C200/ANSI B 36.10/ASTM A-53/IS 3589 keeping selected thickness of pipe as per IS: 3589. Pipe to be fabricated by the bidder shall be rolled and butt welded from plates conforming to ASTM A-53 type 'E' Gr. B/IS 2062. However, larger pipes, i.e. 1000mm Nb and above shall be made from plates conforming to ASTM A 36/IS 2062 and shall meet the requirements of AWWA-M-11 (for deflection and buckling criteria considering water filled pipe, truck-load and weight density for compacted soil).
- vii) The size for DM water pipes shall be to ANSI B 36.19. These shall be socket welded.
- viii) Drinking water lines shall be to ASTM A 53/ANSI B 36.10/IS 1239 Heavy and galvanised to IS 4736 or any equivalent internationally reputed standard. The material of the pipes shall be to ASTM A 53 type 'E' Gr. B/IS 1239 / IS 3589 (thickness to heavy grade as minimum). The fittings shall be either same as parent material or malleable iron to IS-1879 (galvanised). The thickness of pipe shall be at least to schedule "STD" of ANSI B 36.10 (except pipes conforming to IS-1239 Gr. Heavy).
- ix) Condensate lines shall conform to ASTM A 106 Gr. B and sizes as per ANSI B 36.10 schedule STD as minimum to be maintained.
- x) Instrument air and plant air lines sizes shall be to ASTM A 53 Type E Gr. B/ANSI B 36. 10 "Sch. STD"/IS 1239 heavy and galvanised to IS 4736 and screwed. They can be galvanised to any reputed international equivalent code also.

4.5.4 Piping layout

- i) Piping shall be grouped together where practicable and routed to present a neat appearance.
- ii) Piping routing shall be such as to provide sufficient clearance for removal and maintenance of equipment, easy access to valves, instruments and other accessories. The piping shall not encroach on the withdrawal space of various equipments.
- iii) Over head piping shall have a normal minimum vertical clearance of 2.5 m above walkways and working areas and 8m above roadways. When several pipe lines are laid parallel, flanged joints must be staggered. Welded and flanged joints should as far as possible be located at one third span from supports. If the support is situated right under the welded joints this joint must be reinforced with a strap. Flanged and welded joints must be avoided in the middle of the span. Valves should be located in such a manner so as to ensure their convenient operation from the floor or the nearest platform.



- iv) Pipe lines of Nb 50 size and below are regarded as field run piping. It is Bidder's responsibility to plan suitable layouts for these system insitu. Bidder shall prepare drawings indicating the layout of field run pipe work.
- v) All piping shall be routed so as to avoid interference with other pipes and their hangers and supports, electrical cable trays, ventilation ducting, structural members, equipment etc. Adequate clearance shall be ensured with respect to the above to accommodate insulation and pipe movements, if any.
- vi) Piping shall generally be routed above ground but where specifically indicated/approved by the Purchaser, the pipes may be arranged in trenches or buried. FRP/ GRP pipes shall be laid in trenches. Pipes at working temperature above the ambient shall however not be buried.
- vii) Sufficient up stream and down stream lengths shall be provided for flow measuring devices, control valves and other specialties.
- viii) All local instruments shall be located on pipe lines as to render them observable from the nearest available platforms.
- ix) Openings provided in the wall for pipelines must be closed with bricks and mortar with 10-12 mm clearance between brick work and pipe after taking care of insulation and thermal movement, if any. The clear space must be filled with felt or asbestos or approved filling compound.

4.5.5 Slope, Drains and Vents

- i) Suitable slope shall be provided for all pipelines towards drain points. It is bidder's responsibility to identify the requirements of drains and vents, and supply the necessary pipe work, valves, fittings, hangers and supports etc. In addition to the system requirement all low points in the pipelines shall be provided with suitable draining arrangement and all high points shall be provided with vent connections where air or gas pockets may occur. Vent for use during hydrostatic test shall be plugged after the completion of the test. Vent shall not be less than 15mm size. Drains shall be provided at low points and at pockets in piping such that complete drainage of all systems is possible. Drain shall not be less than 15mm for line size upto 150mm, not less than 20mm upto 300mm and not less than 25mm for 350mm to 600mm pipes and not less than 50mm for 600mm and above pipes.
- ii) Air piping shall be sloped so that any part of the system can be drained through the shut-off drain valve or drain plugs.

4.5.6 Pipe Joints

In general all water lines 65mm Nb and above, are to be joined generally by butt welding except the locations where valves/fittings are to be installed with flanged connections and 50mm and below by socket welding unless mentioned otherwise specifically. All air lines shall be of screwed connection and rubber lined pipes of flanged connections.



- i) Screwed:
- a) Threading of pipes shall be carried out after bending, heat treatment etc. If not possible, threading may be done prior to these operations but proper care should be taken to protect them from damage. Threads shall be to ANSI B 2.1 (taper) NPT/IS:554 unless specified otherwise.
 - b) Galvanised pipe shall generally be joined by screwing into sockets. The exposed threaded portion on the outside of the pipes shall be given a zinc silicate coating. Galvanised pipes shall not be joined by welding. Screwed ends of GI pipes shall be thoroughly cleaned and painted with a mixture of red and white lead before jointing. For galvanized pipe sizes of 150 mm Nb and above, either screw & socket jointing or flanged jointing shall be employed. However, the bidder shall ensure the galvanized pipe joints do not fail during hydrotest.
 - c) Teflon tapes shall be used to seal out screwed joints and shall be applied to the male threads only. Threaded parts shall be wiped clean of oil or grease with appropriate solvent if necessary and allowing proper time for drying before applying the sealant. Pipe ends shall be reamed and all chips shall be removed. Screwed flanges shall be attached by screwing the pipe through the flange and the pipe and flange shall be refaced accurately.
- ii) Welded:
- For making up welded joints (butt weld or socket weld) the welding shall be performed by manual shielded metal arc process in accordance with the requirements specified elsewhere in the spec. Any welder employed for carrying butt welding shall be qualified as per ASME section IX for the type of joints he is going to weld. Jointing by butt weld, or socket weld shall depend upon the respective piping material spec.
- iii) Flanged:
- a) All rubber lined pipes shall be flange joined. Flanged connections for other pipes are to be kept to the minimum and used only for connections to vessel, equipments, flanged valves and other fittings like strainer/traps/orifices etc. for ease of connection and maintenance etc.
 - b) All flanged valves intended for installation on steel piping system, shall have their flanges drilled to ANSI B 16.5/IS 6392 (or equivalent) and according to the pressure class stated in their respective piping material specification.
 - c) Drilling on flanges of flanged valves must correspond to the drilling of flanges on the piping system on which the valves are installed.

4.5.7 Joints for Rubber Lined Pipes

Joints for this piping shall be flanged. Flanges for rubber lined piping shall also be rubber lined. Nothing shall be welded to the rubber lined pipes and fittings after rubber lining have been done. All weldments etc. required for supporting the pipes should also be welded before rubber lining. Rubber lined pipe and fittings shall be supplied to dimension



as per the approved drawings. Additional straight pipe and fittings (rubber lined) shall be provided to cover field adjustment. Such field spool pieces and fittings will form a part of work/supply under this package.

4.5.8 Bends, Elbows, Mitre bends, Tees, Reducers and Other Fittings

- i) Unless otherwise specified elbows shall be of long radius type.
- ii) For pipe sizes upto 65Nb, long radius forged elbows or seamless pipe bends shall be used. Pipe bends, if used, shall be cold bent to a radius measured to the centre line of pipe of 3 to 5 times the pipe diameter.
- iii) For steel pipes 80 Nb and above, seamless long radius forged elbows shall be used. For pipe size 350Nb and above mitre bends may be used for all pipes except rubber lined pipes. The bend radius shall be 1½ times the nominal pipe diameter. 90 deg. bends (mitre) shall be in 4 pieces (3 cuts) and 45 deg. mitre bends shall be in 3 pieces 22½ deg. Fabrication of mitre bends shall be as detailed in BS 2633/BS534.
- iv) Mitre bends are not accepted in case of rubber lined mild steel pipes. The steel fittings shall be to ANSI B 16.9/IS 1239 or equivalent.

4.5.9 Flanges

- i) Flanges shall be slip on type. Welding of flanges in tension is not permitted,
- ii) All flanges and flanged drilling shall be to ANSI B 16.5/BS 4504/IS 6392 of relevant pressure/temperature class. Flanges shall be fabricated from steel plates conforming to ASTM A 105/IS 2062/A672 Gr B70 or equivalent.

4.5.10 Specific Technical Requirement of Laying Buried Pipe with Anti-Corrosive Treatment

The pipe in general shall be laid with the top of the pipe minimum 1.0 (one) metre below finished general ground level.

- i) Trenching
 - a) The trench shall be cut true to the line and level and shall follow the gradient of the pipeline. The width of the trench shall be sufficient to give free working space on each side of the pipe. Trenches shall conform to IS 5822.
 - b) Free access shall be provided for the welding of the circumferential joints by increasing the width and depth of the trench at these points. There should be no obstruction to the welder from any side so that good welded joint is obtained.
 - c) The free working space shall conform to IS:5822. The trench shall be excavated so as to provide minimum cover of 1000mm between the top of the pipe and finished grade.



- d) Prior to lowering and laying pipe in any trench, the Bidder shall backfill and compact the bottom of the trench or excavation in accordance with IS:5822 to provide an acceptable bed for placing the pipe.
- ii) Preparation and cleaning of piping
- a) The pipeline shall be thoroughly cleaned of all rust, grease, dirt, weld scales and weld burrs etc. moisture or other foreign matter by power cleaning method. Grease or heavy oil shall be removed by washing with a volatile solvent such as gasoline. Kerosene will not be permitted for cleaning. This cleaning operation shall be immediately followed by priming.
- b) The cleaning and priming operation shall be carried out at site. The entire pipe length shall be cleaned.
- c) On the internal surface for pipes 1000 Nb and above, a coat of primer followed by a hot coal-tar enamel shall be applied. Suitable internal protection for sea-water corrosion on the internal surface of all pipes shall be provided.
- iii) Coating and wrapping
- a) Buried piping shall be coated and wrapped, as per specification, after completion of welded and/or flanged connections and after completion and approval of Hydro testing. Materials to be used for coating and wrapping of underground pipelines are :
- Coating primer (coal tar primer)
 - Coating enamel (coal tar enamel)
 - Wrapping materials.
- b) All primer/coating/wrapping materials and methods of application shall conform to IS: 10221. Materials (primer/ coating/ wrapping) as per AWWA-C-203 are also acceptable.
- c) Total thickness of completed coating shall not be less than 3.2mm.
- iv) Trench bed preparation and back filling
- Prior to lowering and laying pipe in any excavated trench, the bottom of the trench shall be back filled and compacted (or as the case may be) to provide an acceptable bed for placing the pipe. Bed preparation in general shall be as per IS:5822.
- v) Laying of galvanised steel (GI) pipes
- All the joints shall be screwed with socket or flanged. Screwed ends of GI pipes shall be thoroughly cleaned and painted with a mixture of red and white lead before jointing threaded portion on either side of the socket joint shall be applied with Zinc silicate paste.



All the provisions for trenching/bed preparation/laying the pipe application of primer/coating/wrapping with tapes/back filling etc. as indicated for “laying of buried piping” and “anti corrosive protection for buried piping” are applicable for buried galvanised steel (GI) pipes also.

4.5.11 Cleaning and Flushing

- i) All piping shall, be cleaned by the bidder before and after erection to remove grease, dirt, dust, scale and welding slag.
- ii) Before erection all fabricated pipework, assemblies, sub-assemblies, fittings, and components, etc. shall be thoroughly cleaned internally and externally by blast cleaning or by power driven wire brushes. The brushes shall be of the same or similar material as the metal being cleaned.
- iii) After erection, all water lines shall be mass flushed with water. The cleaning velocities in water lines shall be 1.2-1.5 times the operating velocities in the pipelines.
- iv) All compressed air pipework shall be cleaned by blowing compressed air

4.5.12 Surface Preparation and Painting

Pipes shall be cleaned both internally and externally thoroughly. The Bidder shall clean the internal surfaces of piping before erection by wire brushing and air blowing. In case of oil piping, cleaning will have to be done by pickling. No painting is required on galvanized pipe surface or galvanized steel surface. However, necessary colour banding for identification as per colour code shall be done. External surface of piping shall be cleaned and prepared as indicated below.

- i) Primer painting
 - a) After the surface is prepared in a manner acceptable to the Project Manager two coats of red oxide (zinc chromate) primer conforming to IS-2074 or equivalent shall be applied. Primer shall be applied by brushing to ensure a continuous film without holidays. Primer coat shall be immediately applied without any time lag after the surface preparation.
 - b) Any equipment which has been given the shop coat of primer shall be carefully examined after its erection in the field and shall be treated with a touch up coat of red oxide primer wherever the shop coat has been abraded, removed or damaged during transit/erection, or defaced during welding.
- ii) Finish painting
 - a) Paint to be used shall be synthetic enamel paint conforming to IS-2932 or equivalent. The manufacturer of paints and colour/shade shall be as approved by the purchaser.



- b) Finish painting shall be carried out in three coats consisting of one under coat and two finishing coats of distinguishable shades.
 - c) The requirements of workmanship is as specified in IS-1477.
 - d) No painting shall be done in frost/foggy weather or when the humidity is high to cause-condensation on the surface to be painted.
- iii) Other requirements
- a) Paint manufacturers instructions shall be followed in method of application, handling, drying time etc.
 - b) The colour of the finish paint shall be as per approved colour coding.
 - c) If finish paint was applied in shop, one coat of finish paint shall be applied at site.
 - d) The dry film thickness of finish paint shall not be less than 0.15 mm.
- iv) Colour code for identification

The pipes shall be colour painted/banded for identification as per the approved colour coding scheme and shall be generally as per IS-9404.

4.5.13 Hangers and Supports

- i) All hangers, supports and parts shall conform to the requirement of power piping code ANSI B 31.1 or approved equivalent.
- ii) While designing supports for rubber lined pipes special consideration should be given. Any kind of welding on these pipes is not allowed after rubber lining.
- iii) Hangers, trestles, saddles, supports etc. shall be fabricated from plates/pipes sections conforming to ASTM A 53/IS:2062 or equivalent. They shall be designed to provide the required supporting effects and allow pipe line movements as necessary. The structural steel work shall be as per IS:800/BS:4360. Insulation protection saddles shall be used at support point of all insulated piping.
- iv) The support shall be so interspaced as to minimise sagging of the pipes and to keep them within permissible limits where pipes are full with the conveying media.
- v) All hangers/supports and their components shall be given two (2) shop priming coats of red oxide paint.
- vi) The maximum spans of the supports of straight length shall not exceed the recommended values indicated in ANSI B 31.1.
- vii) All pipe supports shall be designed to provide an absolute minimum head room of 2.2 m from floor in passages/ walkways.



- viii) At all sliding surfaces of supports suitable arrangement is to be provided to minimise sliding friction.

4.5.14 Design/ Construction of Gate/ Globe/ Check/ Stop/ Butterfly Valves

i) General

- a) All valves shall be suitable for the service conditions i.e flow, temperature and pressure, at which they are required to operate.
- b) The valves as well as all accessories shall be designed for easy disassembly and maintenance.
- c) Valves to be installed outside shall be required to have the stem properly protected against atmospheric corrosion.
- d) All rising stem valves shall be provided with back seat to permit repacking (of glands) with valves in operation. All valves shall preferably be of outside screw and yoke type.
- e) All valves shall be closed by rotating the hand wheel in the clockwise direction when looking at the face of the handwheel. In case where the handwheel is not directly attached to the valve spindle suitable gearing shall be introduced.
- f) All valves shall have indicators or direction clearly marked on the hand-wheel so that the valves opening/closing can be readily determined.
- g) Special attention shall be given to operating mechanism for large size valves with a view to obtaining quick and easy operation ensuring that a minimum of maintenance is required. For valves of size 350mm and above either bevel or spur gearing shall be provided to facilitate manual operation.
- h) The valves coming in vacuum lines shall be of extended gland type and/or water sealed.
- i) Valves coming under the purview of IBR shall meet IBR requirements.
- j) Gate/slucice valves shall be used for isolation of flow. Gate valves shall be provided with the following accessories in addition to other standard items :
 - Hand wheel
 - Position indicator
 - Gear operators for valves of size 350 NB & above.
- k) Globe valves shall be used for regulation purposes. They shall be provided with hand wheel, position indicator, draining arrangement (wherever required) and arrow indicating flow direction.



- l) Check valves shall be used for non-return service. They shall be swing check type or double door (flap) plate check type with a permanent arrow inscription on the valve body indicating the fluid flow direction. Valves up to and including 50mm may be piston lift NRV as per applicable standard.
- m) All gate and globe valves shall be provided with back seating arrangement to enable on line changing of gland packing.
- n) All gate and globe valves shall be rising stem type and shall have limit switches for full OPEN and full CLOSED indication wherever required.
- o) All valves shall be provided with embossed name plate giving details such as tag number, type, size etc.
- p) Valve body material for various services shall be as follows:
 - Raw water, clarified water, CW blow down water, circulating water, compressed air & drinking water - CI.
 - DM water - SS
 - Condensate, pH corrected DM water - CS
- ii) End connections
 - a) The end connections shall comply with the following:
 - Socket welding (SW) - ANSI B 16.11
 - Butt welding (BW) - ANSI B 16.25.
 - Threaded (SC) - ANSI B 2.1
 - Flanged (FL) - ANSI B 16.5
 - b) All cast iron body valves (gate, globe and non-return) shall have flanged end connections, (screwed ends for cast iron body valves are not acceptable).
 - c) All steel and stainless steel body valves of sizes 65 mm and above shall have flanged or butt weldings ends. Valves of sizes below 65mm shall have flanged or socket welded ends.
 - d) All flanged end valves/specialities shall be furnished alongwith matching counter flanges, fasteners, gaskets etc. as required to complete the joints.
- iii) Check valves
 - a) In the case of swing check valves, the body seat shall be vertical or inclined at such an angle from the vertical as will facilitate closing and prevent chatter.



- b) Counter flanges to be installed on air pipes shall be screwed-on type irrespective of size.
- iv) Globe valves
- a) The globe valves shall have the following characteristics:
- Straight conveyed flow.
 - Right angle
 - Preferably, the valves shall be of the vertical stem type.
- b) Globe valves shall preferably have radius or spherical seating and discs shall be free to revolve on the spindle.
- c) Globe valves with size smaller than or equal to 50 Nb shall be of the integral type. Valves of this type shall permit the easy disassembly of the internals (stem and disc).
- d) For the regulating valves (valves with regulating plug); parabolic outline disc type is preferred.
- e) All motorised globe valves with regulating plug for which indication of percentage (%) opening are required in the control room shall be provided with necessary position transmitter.
- v) Gate valves
- a) All gate valves shall be of the full-way type, and when in the full open position the bore of the valve shall not be constricted by any part of the gate.
- b) Gate valves shall be of the solid/elastic or articulated wedge disc and rising stem type.
- vi) Air release valves
- a) The air release valve shall be of automatic double air valve with two orifices and two floats which shall not close the valve at higher air velocity. The orifice contact with the float shall be leak tight joint.
- b) Body material of automatic air release valves shall comply generally with BS 1452 Gr. 14/IS:210 Gr. FG 260 and spindle shall conform to high tensile brass.
- vii) Butterfly valves
- a) The valves shall be designed for the design pressure/temperature of the system on which it is installed and in accordance with AWWA-C-504, BS: 5155 or



Section- 4 (Piping, Valves, Thermal Insulation and Miscellaneous Systems/ Equipment)

any other approved equivalent standard latest edition. Fabricated butterfly valves instead of cast body valves are also acceptable for large size (600 mm diameter and above).

- b) The design of the shaft shall be such that it will safely sustain maximum differential pressure across the closed valve. The shaft and any key (taper pin etc.) for transmitting the torque between shaft and disc shall be capable of withstanding the maximum torque required to operate the valve.
- c) The disc shall rotate from the full open to the tight shut position. The disc shall be contoured to ensure the least possible resistance to flow and shall be suitable for throttling operation. While the disc is in the throttled position, valve shall not create any noise or vibration.
- d) The operating mechanism shall be mounted directly on or supported from the valve body.
- e) Hand operated valves of 350Nb and above shall also be provided with gear operator arrangement suitable for manual operation. Manual operation of valve shall be through worm and gear arrangement having totally enclosed gearing with hand wheel diameter and gear ratio designed to meet the required operating torque. It shall be designed to hold the valve disc in intermediate position between full open and full closed position without creeping or fluttering. Adjustable stops shall be provided to prevent over travel in either direction.

viii) Material of construction (gate, globe and check valves)

The material of valves used shall be as per the following or their equivalent or superior grade.

a) Cast steel valves:

Body and bonnet	:	ASTM A 216 Gr. WCB/ ASTM A 105
Disc for non-return valves	:	-do-
Trim	:	ASTM A 182 Gr. F6

b) Stainless steel valves:

Body, bonnet and disc	:	ASTM A 351 Gr. CF 8M/ ASTM A 182 Gr. 304.
Trim	:	ASTM 182 Gr. F. 316.

c) Cast iron valves:

Body & bonnet	:	BS 1452 Gr. 14/ IS-210 Gr. FG 260.
---------------	---	---------------------------------------



Seating surfaces and rings	:	13% chromium steel.
Disc for non-return valves	:	BS 1452 Gr.14/IS: 210 Gr. FG 260
Hinge pin for NRVs	:	AISI 316
Stem for gate globe valves:		13% chromium steel.
Back seat	:	13 % chromium steel.
d) Cast iron butterfly valves:		
Body & disc	:	ASTM A48, Gr. 40 with 2% Ni/ IS:210 Gr. FG-260, with 2% Ni and epoxy coated
Shaft	:	BS 970 43 IS:291/EN 57
Seat ring	:	18-8 Stainless steel
Seal	:	Nitrile Rubber
e) Stainless steel butterfly valves:		
Body & disc	:	ASTMA351,Gr. CF8M
Shaft	:	ASTM A 182, Gr. 316
Disc & seat rings	:	EPT/BUNA-N/Neoprene
f) Carbon steel butterfly valves:		
Body & disc	:	ASTM A 216, Gr. WCB
Shaft	:	ASTM A 182, Gr. 304
Disc & seat ring	:	EPT/BUNA-N/Neoprene

Testing of BF valves shall be as per AWWA C-504/BS-5155. For fabricated body butterfly valves all the longitudinal/ circumferential weld seams on valve body shall be 100% radiographed.

g) Material for counter flanges shall be the same as for the piping.



4.6 THERMAL INSULATION AND REFRACTORIES

4.6.1 General Requirements

- i) Thermal insulation shall be provided mainly for the following reasons.
 - a) Conservation of heat and maintenance of temperature as per design cycle.
 - b) Personnel protection.
- ii) Insulation alongwith aluminum cladding shall be provided for all the equipments/surfaces (excluding coal pulverisers) having skin temperature more than 60 deg. C.
- iii) Design for personnel protection:

For the piping and the equipment with surface operating temperature of 60⁰C and above, the personnel protection insulation shall be applied such that the temperature of protective cladding is below 60⁰C.
- iv) The Contractor shall prepare an insulation thickness schedule covering both the cases of heat conservation and personnel protection based on the following design data:
 - a) Design ambient temperature : 40⁰C
 - b) Maximum cladding temperature : 60⁰C
 - c) Wind speed : 0.25m/sec.
(0.5 m/sec where the heat loss is not the criteria)
 - d) Emissivity of cladding : 0.2
 - e) Thermal conductivity : As per relevant Indian Standard
 - f) The minimum acceptable insulation thickness : 75 mm for Boiler & TG
70 mm for ESP surfaces
25 mm for other surfaces
 - g) Pipe/equipment wall temperature : Fluid design temperature
- v) The calculated insulation thickness or thickness as mentioned above, whichever is higher shall be provided as per requirements.



4.6.2 Technical Requirements

- i) All insulating materials, accessories and protective covering shall be non-sulphurous, incombustible, low chloride content, chemically rot proof, non-hygroscopic and shall be guaranteed to withstand continuously and without deterioration the maximum temperature to which they will be subjected under the specified conditions.
- ii) The use of insulation of finishing materials containing asbestos in any form is not permitted. The insulation compound shall not contain any substance detrimental to health.
- iii) Insulation mattress/section shall be supplied in thickness of 25, 40, 50 and 75 mm. Insulation of higher thickness shall be made up in multiple layers using mattress/slabs of thickness specified above. However, if the required thickness is not achieved, the mattress/slabs in increment of 5mm shall be acceptable. The minimum thickness shall not be less than 25 mm, the number of layers shall be minimum and the innermost layer shall be the thickest.
- iv) The durability and adherence of insulation layer on the bottom of the equipment is of particular importance, therefore, special attention shall be paid to this when the insulation is designed and applied.
- v) Special fire protection measures shall be taken for the steam lines running in the immediate vicinity of oil lines. The sheet metal jacketing shall be made oil proof by inserting self-adhesive flexible tapes.
- vi) Rock wool insulation mattress shall be of long fibered rock processed into fibrous form bonded with a binder. No kind of slag wool inclusion is acceptable.
- vii) Clean water shall be used in mixing insulating or covering components. Care shall be taken that brackish or salt water is not used for this purpose.
- viii) All insulation shall conform to the quality requirements laid down below and test certificates on samples from the lot to be supplied shall be furnished to the Purchaser for approval.
- ix) The use of asbestos in any form for insulation and elsewhere is not permitted.
- x) The thermal conductivity of the insulating material to be considered for the design of thickness of insulation shall be the maximum value as per the relevant standard to which the material belongs.



4.6.3 Materials of Insulation

i) Technical details

Type	Type # 1	Type # 2	Type # 3	Type # 4	Type # 5
Material	Lightly resin bonded mineral (rock) wool	Resin bonded mineral (rock) wool pre-formed pipe sections/ blocks	Calcium silicate pre-formed pipe sections/blocks	Rock wool for spray insulation	Ceramic fibre blankets/blocks
Apparent density	100 kg/m ³ for temp. 60-400° C 150 kg/m ³ for above 400° C	140-150 kg/m ³	200-250 kg/m ³	200-250 kg/m ³	128 kg/m ³
Material standard & testing code	IS: 8183	IS: 9842	IS: 9428	IS: 9742	IS: 15402
Applicable service	Piping system & equipment with operating temp. range of 60-650° C	Piping system of 350 NB and below with temp. in range of 60-400° C	Piping system & equipment with operating temp. in range of 400-650° C	Steam turbine & valves operating temp. range of 400-650° C	Steam turbine, boiler surfaces & valves operating temperature range of 400-650° C



ii) Sheathing/cladding material

Sheathing/cladding material for all insulated surfaces. equipment, piping etc. conforming to ASTM B 209-1060 temper H-14 or IS-737 Gr.19000/H2 shall be provided as follows:

	<u>With lightly bonded mattress</u>	<u>With preformed pipe sections</u>
a) For dia of insulated surfaces of 450 mm & above and for flat surfaces	1.63 mm (16 SWG)	_____
b) For dia of insulated surfaces less than 450 mm	0.914mm (20Swg)	0.914mm (20Swg)
c) For steam generator outer casing	1.63 mm (16 SWG) ribbed Aluminium	_____

iii) Binding and lacing wires

	<u>Material</u>	<u>Thickness</u>
a) Upto 400 ⁰ C	Galvanised steel	20 SWG
b) Above 400 ⁰ C	Stainless steel	20 SWG

iv) Straps and bands

- a) Materials of straps and bends shall be as under:
- Upto 400⁰C Galvanised steel
 - Above 400⁰C Stainless steel
- b) Bands shall be 20 mm wide and 0.6 mm thick
- c) For securing aluminium sheathing material, stainless steel or anodised aluminium bands shall be used.
- d) Screws shall be of galvanised steel, check headed, self-tapping type. For temp. above 400⁰C, screws shall be stainless steel.
- e) Hexagonal wire mesh shall be conforming to following:

	<u>Material</u>	<u>Mesh size</u>
• Upto 400 ⁰ C	Galvanised steel	10 to 13 mm aperture 0.71 mm diameter
• Above 400 ⁰ C	Stainless Steel	-do-



- v) Bonding agent
- Shall be alkali silicate based, formulated with surface drying additives-self setting.
 - Shall be suitable for temperature applications upto 900⁰C.
 - Shall be non-corrosive, non toxic and non-inflammable.
 - Shall be free from unreacted matter.
 - Shall not require internal, or external drying; thus eliminating requirement of steam heating.
- vi) Hard setting cement/ finishing cement plaster
- This shall conform to IS:9743 Type I or equivalent. When mixed with water, it shall be able to develop a plastic consistency to readily adhere to thermal insulation and dry to form a smooth, hard protective surface. It shall not develop cracks for temperature upto 175⁰C. Asbestos free and chemically inert open woven fibre shall be used as reinforcement to the hard cement plaster for achieving extra strength.
- vii) Others accessories
- The Contractor shall also provide other accessories such as ceramic boards, sealants and washers as required.

4.6.4 Refractories

- i) The refractory material shall comply with relevant Indian Standards. The refractory selected shall ensure perfect sealing, and shall have good thermal cycling properties allowing quick start-up/shut down of steam generators.
- ii) The refractory material shall
- a) have high bulk density and minimum moisture content.
 - b) be capable of withstanding service temperature of 1700 deg. C.
 - c) be resistant to slagging products due to coal, and to impurities of oil like V₂O₅, Fe₂O₃, K₂O, etc. and to erosion due to fly ash.
 - d) be chemically inactive towards alkalies, iron, silica etc.,
 - e) shall pose no health hazard to working personnel, and shall not have any explosive properties.



- f) have sufficient strength to withstand forces generated in boiler, without any rupture or damage.
- ii) Application of refractory
 - a) It shall ensure perfect sealing, easy maintenance, minimum time for application.
 - b) Number of joints shall be minimum. All the joints shall be filled and tightly packed with loose powder of same material.
 - c) Selection of refractory shall consider the applied stress distribution and expansion allowance.
 - d) Refractory shall have good thermal cycling properties to ensure quick start up and shut down of steam generators.

4.6.5 Application Procedure for Thermal Insulation and Refractories

- i) General
 - a) All surfaces to be insulated shall be cleaned of all foreign materials such as dirt, grease, paint residue, loose scale and rust etc., and shall be dry before the application of insulation.
 - b) Before applying the insulation the contractor shall check that all instrument tapping, clamps, lugs and other connections on the surface to be insulated have been properly installed as per the relevant erection drawing.
 - c) Firm anchoring shall be welded onto the pads/strips already provided on the body of the casings/equipments. Pads/strips in addition to those already provided shall be attached only with the approval from purchaser.
 - d) All flanged joints shall be insulated only after the final tightening and testing.
 - e) The insulation shall be applied to all surfaces when they are at ambient temp. Ample provision shall be made for the maximum possible thermal movement and the insulation shall be applied so as to avoid breaking/telescoping due to alternate periods of expansion and contraction.
 - f) All cracks, voids and depressions shall be filled with finishing cement, suitable for the equipment-operating temp. so as to form a smooth base for the application of cladding.



- ii) Installation on steam turbine and BFP drive turbine
- a) The HP cylinder, IP cylinder, steam chest and interconnection piping, crossover / cross-around piping, such parts of LP cylinder as considered necessary, and all associated piping and valves shall be efficiently insulated with suitable thermal insulating materials. The insulated portion of the steam turbines shall be covered with fabricated steel cover, provided with suitable anti-drumming and sound pressure attenuating material inside. The insulation and steel covering should be so designed and erected as to provide easy accessibility to parts requiring frequent inspection.
 - b) The thermal insulation for the turbine casing shall consist of sprayed insulation produced by projecting specially prepared mineral wool along with a fine liquid spray. This should be covered with prefabricated 'blanket' type insulation. These blankets shall consist of high temperature felted mineral insulation fully enclosed in wire inserted asbestos free cloth for temperature exposure to 445°C to 595°C. A single layer of blanket shall not be more than 75 mm thick. Voids around the blankets should be avoided. However, unavoidable voids shall be filled with loose mineral wool.
 - c) Bidder at its option may offer ceramic blankets for the steam turbine insulation.
 - d) The difference in metallic temperatures of upper and lower halves of both HP and IP casings, during normal operating conditions shall not be more than 15°C.
 - e) Suitable stainless steel lugs shall be tack welded on turbine casing to support the insulation. In places where welding is not permitted, suitable alternative arrangement shall be provided by the Contractor. The design of the support shall be so as to involve minimum number of lugs.
 - f) Studs and cap nut/nuts in the area of spray insulation shall be covered with aluminium foil to prevent the ingress & caking of contaminants.
 - g) The construction of the insulation at the flange joints of the casings shall be such that it can be easily removed and put again without causing major damage to the main insulation while opening the casings for carrying out the maintenance of the machine. It shall also be ensured that no weak spot exists in the insulation of flange joints and pipe connections.
 - h) At the front and rear ends of the turbine casings, aluminium shield plate of 2mm thickness shall be provided to prevent the oil from seeping out of the bearing pedestals into the insulation. Whenever possible, the distance of the shield plate from the bearing pedestal cover shall be 40mm. The shield



plates are to be fastened suitably. The bearing cover bolts shall be accessible, and the dismantling of the bearing pedestal covers shall not be impeded by the shield plates.

- i) All thermo couples shall be marked with sleeves made out of 0.71 mm aluminium sheet for proper access during maintenance and replacement when and where necessary.
- j) The ability to function and ease of access to the covers and blind flanges shall not be impaired by the insulation.
- k) Applicable Standards :
 - IS – 9742 Sprayed mineral wool thermal insulation.
 - IS – 5696 Loose mineral wool.
 - IS – 3677 Unbonded rock and slag wool for thermal insulation.
 - IS – 8183 Lightly bonded mineral wool for thermal insulation.
 - IS – 15402 Ceramic blankets
 - IS – 9842 Preformed fibrous pipe insulation
 - IS – 3144 Methods of test for mineral wool insulation materials
 - IS – 9428 Pre-formed calcium silicate insulation

iii) Installation on valves and fittings

All valves, fittings and specialties shall be insulated with the same type and thickness of insulation as specified for the connected piping with the special provisions and or exceptions as given below.

- a) All valves and flanges shall be provided with removable box type of insulation covered with box fabricated from aluminium sheets of thickness same as the connected pipe cladding. Adjoining pipe insulation shall be bevelled back to permit removal bolts and nuts or bands. The portion of the valve which can not be covered by box type insulation shall be filled by loose insulating material of packing density at least equal to that of the insulating material of adjoining pipe. The insulation for valves/flanges shall be applied after the finishing has been applied over the connected piping. The cladding shall be applied in such a manner that the bonnet flange can be exposed easily without disturbing the complete insulation and cladding.
- b) High temperature valves such as turbine valves and HP and LP bypass valves shall be insulated with sprayed type insulation as provided for turbine casing.
- c) For expansion joints the insulation, wherever applicable, shall be applied in such a way that it does not hinder the functioning of the joint.
- d) Safety valves shall be suitably insulated.



- iv) Installation on piping
- a) All vertical pipes shall be provided with the suitable insulation supports to prevent collapsing/crushing of insulation due to its self-weight. Support rings shall be provided at a spacing of 3 metres on all vertical piping with a vertical length of 4 meter or above.
 - b) Longitudinal joints of insulation mattresses sections of horizontal piping shall be on the bottom or at the sides of the pipe.
 - c) When more than one layer of insulation mattress/section is required on piping the circumferential joints on adjacent layers shall be staggered by atleast 150 mm and longitudinal joints shall be staggered by atleast 50 mm.
 - d) The mattress type insulation shall be formed to fit the pipe and applied with the mattress edges drawn together at the longitudinal joints and secured by lacing wire. Pipe section insulation shall be fitted on pipe using binding wires.
 - e) Where insulation is applied in two or more layers each layer of mattress shall be backed with hexagonal wire mesh. For the first layer of insulation and in case of single layer insulation, hexagonal wire mesh shall be provided on both the surface of the mattress. For pipe sections, the pre-formed sections shall be held in place by binding wires without any wire mesh.
 - f) The ends of all wire loops shall be firmly twisted together with pliers, bent over and carefully pressed into the surface of the insulation. Any gap in the insulation shall be filled with loose mineral wool or finishing cement.
 - g) Insulation mattress/section ends shall be terminated at a sufficient distance from the flanges to facilitate removal of bolts.
 - h) The insulation shall be held in place by fastening over with binding wire for insulation surface with diameter upto and including 550 mm and with metal bends for insulation surfaces with diameter over 550 mm. The fastening shall be done at intervals of 250 mm except where specified otherwise. The ends of the binding wires shall be hooked and embedded in the insulation. The straps shall be mechanically stretched and fastened with metallic clamping seals of the same materials as the strap.
 - i) Insulation for application on bends and elbows shall be cut into mitred segments, sufficiently short to form a reasonably smooth internal surface. After the application of insulation material in place, insulating cement shall be applied as required to obtain a smooth surface.
 - j) Weather hoods shall be provided for insulated piping passing through floors/walls.



- k) All pipe attachments coming on horizontal pipes, inclined pipes and bends shall be insulated alongwith pipe such that there will be no insulation applied to hanger rod and the component connecting hanger rod to pipe attachment. All pipe attachments exposed to weather shall be provided with weather proof.
- l) Upstream of all drain lines and the lines connected to steam traps, shall be insulated upto and including first isolating valve for heat conservation. Rest of such lines such as downstream of the drain valves, traps etc. and other lines such as safety valve discharges, vents, etc. shall be insulated for personnel protection.
- v) Installation on steam generator and other flat surfaces/ equipments.
- a) Insulation to various areas shall be applied as under:
- | | | |
|---|---|---|
| Boiler surfaces, hot air/gas ducts, ESP, piping & headers | : | Mineral wool blocks or mineral wool blankets |
| All other surfaces (not enclosed by boiler casing) | : | Calcium silicate block or mineral wool/ceramic blocks or blankets |
- b) For the steam generator furnace where provided with skin casing and the casings where water cooled walls are not involved such as second pass, first a covering of refractory material shall be applied before the application of any further heat resistant insulating material.
- c) The access doors and inspection doors in the boiler shall be lined with refractory material. The access doors in other portions of the steam generator shall be insulated in a similar manner corresponding to any casing; flue-ducts or air ducts where such openings and access doors occur.
- vi) Installation on equipment
- a) The insulation applied to the equipment shall be reinforced with hexagonal wire mesh. One layer of wire mesh shall be provided on the equipment surface prior to application of insulation.
- b) Installation on horizontal cylindrical vessel/tanks (including heaters, heat exchanger etc.).

All the surfaces of insulation layers, applied on horizontal cylindrical vessels shall be securely fastened by bands upto vessel/tank outer diameter of 150 mm and below. Where vessel/tank outer diameter exceeds 1500 mm, binding wire passing through insulation clips provided both longitudinally and circumferentially at 500 mm centers shall be used. Gaps in the insulation shall be filled with loose mineral wool and finished with finishing cement so as to obtain a smooth surface for the application of cladding. The contractor shall provide support ribs/lugs on the surface of the vessel/tank as necessary. The contractor shall obtain the approval of the



'Purchaser' and the equipment supplier's field engineering representative before performing any welding on equipment. The contractor shall perform any heat treatment requirement as per recommendation of equipment supplier.

c) Installation on vertical cylindrical vessel/ tanks (including flash tanks etc.):

All vertical vessels/tanks shall be provided with support rings/ribs with other necessary framework to take up the weight of the insulation prior to heat treatment. The contractor shall obtain the approval of the 'Purchaser' and the equipment supplier's field engineering representative before performing any welding on equipment. The contractor shall perform any heat treatment requirement as per recommendation of equipment supplier.

The mattresses shall be held in position by means of 9 SWG steel wire nails, the nails being 25 mm longer than the thickness of insulation to be applied. After the mattresses have been placed over the nails, the nails shall be bent and embedded in the insulation. Alternatively, wire loops may be tack welded at 250-mm centers to hold the insulation in place.

vii) Installation of cladding

- a) All insulation shall be protected by means of an outer covering of aluminium sheathing. All insulation/cladding joints shall be sealed and made effectively weather and waterproof. All flat surfaces shall be given suitable slope to prevent collection of pools of water on the cladding surface. All sheathing shall be protected internally by the application of two coats of bitumenastic paint.
- b) For piping in plants near the sea, the Aluminium sheet shall be subjected to special surface treatment of Al Mg Mn material (Resistant to seawater).
- c) All longitudinal joints shall have a minimum overlap of 50 mm and shall be located at 45 deg. or more below the horizontal for horizontal equipment. Joints shall be made with cheese headed self tapping galvanized steel screws at 150 mm centers.
- d) All circumferential joints shall have a minimum overlap of 100 mm and shall be held in position by stainless steel or anodized aluminium bands, stretched and clamped.
- e) Removable box type cladding for valves and flanges shall be fitted on the connected pipe cladding, with bands.
- f) Aluminium cladding shall not come directly into contact with either the equipment surface or with the supporting arrangement on the equipment surface. To this end, adequate layers of 3 mm thick ceramic board shall be provided between the cladding and any supporting arrangement equipment surface, and fitted with self tapping screws/metal bands, as applicable.



- g) For bends, fittings etc. the cladding shall be provided in segments as to ensure a smooth finish of the cladding.
 - h) For cladding on vertical pipes/equipment, provision for load take up shall be made at every 2 to 4 metres along pipe/equipment axis.
 - i) All joints shall be sealed with acrylic emulsion weather barrier.
 - j) Galvanic corrosion shall be prevented by carefully avoiding permanent contact of aluminium cladding with copper, copper alloys, tin, lead, nickel or nickel alloys including monel metal.
- viii) Testing and guarantees

All tests, as per the applicable material standards and as specified shall be carried out in accordance with the methods prescribed. Purchaser shall have the right to witness any or all of the tests conducted by the contractor at the shop or laboratory.

The Contractor shall guarantee that if on actual measurement the specified maximum insulation surface temperatures are exceeded, the contractor shall either replace the insulation with a superior material or provide additional insulation thickness at no extra cost.



4.7 MAIN PLANT EOT CRANE

One number EOT crane shall be provided for the TG hall. The crane shall be electrically operated indoor travelling type with span to suit the requirement of turbine hall. The crane capacity shall be to handle the weight of single heaviest piece in the turbine hall with 10% margin (except for generator stator which needs to be handled by separate arrangement). The capacity of auxiliary hook shall be minimum 25 T.

4.7.1 Design Requirements and Constructional Features

- i) The approximate maximum full load speeds shall be as below:
 - a) Main hoist : 1.6 m/ min.
 - b) Auxiliary hoist : 7.5 m/ min.
 - c) Trolley travel : 15 m/ min.
 - d) Crane travel : 30m/ min.
 - e) Creep speed of main and auxiliary hooks : 10% of maximum speed
 - f) Creep speed cross travel & long travel : 10% of maximum speed
- ii) The crane shall be complete with all equipment, accessories like operator's cabin, bridge girder, lifting beam, hook block assembly, runway length, trolley rails, rail end stops, rail joints and fixing, trolley frame, platforms and ladders, repair cage, gearing, bearing, brakes etc. as per Group M5 of IS : 3177 and IS : 807.
- iii) The crane shall be complete with all electrical equipment, accessories (like drive motors, electrically operated brakes, controllers, resistors, conductors, insulators, protective and operating devices, cables, current collectors, etc.) and cabling/wiring as may be necessary for the efficient, safe and satisfactory operation and maintenance of the crane. Down shop leads (DSL) shall be MS Angle Type, ISA – 75 x 75 x 6 sections.
- iv) In the design of components on the basis of strength, the factor of safety shall not be less than five (5) based on ultimate strength. The crane shall be rigid in construction and all movements shall be smooth and non-jerky. For compression members, the slenderness ratio shall not exceed 120. In case of other load carrying members and subsidiary members the slenderness ratio shall not exceed 180. For girders, the maximum span to depth ratio shall be 18 for plate girder and 12 for lattice girder.
- v) All motors shall conform to the latest applicable IS/IEC or equivalent. The electric motors for hoisting motion, cross-traverse, long-traverse shall in addition conform to IS: 325 and IS: 3177. Motor enclosures shall conform to the degree of protection IP-55. The motor shall have insulation class "F" with temperature rise limited to 70°C. Motors shall be slip-ring wound rotor type designed for crane duty requirement of frequent starting, reversing and plugging. For creep speed, motor may be designed for DOL starting. Enclosure protection class of electrical panel shall be IP-54 except for resistance box having protection class of IP-23.



- vi) The runway conductor shall be four (4) in number for three phase supply and ground. Cross conductor on bridge shall be flexible trailing cable system mounted on retracting supports (festoon type).
- vii) Spring type end buffers shall be provided on trolley, end carriages, crane structure and gantry girders to reduce shock & impact on the crane and building structure.
- viii) Access walkways shall be provided on both side of bridge girder and for cross over. The width of walkways shall be of minimum 800 mm with hand railing of height of 1100 mm.
- ix) Bridge girder and end truck

The bridge girder shall be box section type or braced I - beam type as per standard design of the manufacturer. The crane bridge shall be carried on end trucks of suitable design. End trucks shall be equipped with spring/rubber buffers and rail sweep for bridge travel. End trucks shall also be provided with suitable jacking pads for maintenance of the wheel and bearings.

- x) Trolley frame

The trolley frame shall be built up from heavy steel plates, angles and channels adequately braced to resist vertical, lateral and torsion strains, welded to form a rigid one piece frame. Alternatively, it may be of cast steel construction and should be covered by flooring as far as possible.

- xi) Operator's cabin

The operator's cabin shall be steel fabricated open type, suitable for indoor service, fire proof construction and complete with light, fan and seat. The cabin shall be located on one end of the crane bridge and on the opposite side of Down Shop Lead (DSL) and under one of the bridge girders, so that it is offset to one side. Cabin shall be compact and adequately sized (approximately 2.5x2x2 metres clear high) to accommodate all required control equipment. Arrangement shall be such as to provide unrestricted view of load at any position by the operator. The cabin shall be provided with guarding handrails and the floor shall be covered with electric insulating carpet. The cabin shall be well braced in order to provide adequate strength and rigidity. The Cabin Head room clearance shall be 2400mm.

- xii) Repair cage

A repair cage shall be provided on the inside of the end carriage for attending the main current collectors.

- xiii) Lifting beam and hook block assembly

The lifting beam shall be fabricated out of tested quality mild steel plates or sections shall be complete with all needed accessories. The lifting hook block



assembly shall be ramshorn type for Main Hoist and point hook with shank for Auxiliary Hoist. Each hook shall be supported on ball or roller thrust bearing and shall rotate freely on its bearings.

xiv) Gearing

Gears in the speed reducer unit for bridge drive and also all hoists and trolley drive gearing shall be totally enclosed in substantial housing and shall operate in oil bath. All Gears shall be of helical gear type. Gears shall be of cast or forged steel and pinions shall be forged steel and shall be machine cut. Gear and pinion teeth shall be treated for resistance to wear.

xv) Runway/ trolley rails

Rails shall be as per IS: 3443 and joints shall be butt welded by thermit welding and fusion welding.

xvi) Illumination

Adequate illumination shall be provided by HPSV lamps under the bridge and by fluorescent lamp over the bridge and inside the cabin.

xvii) Brakes

For bridge/crab travel and main/auxiliary hoist mechanisms Electro-hydraulic Thruster Operated Brakes and Electro-magnetic brakes shall be provided. All brakes shall be adequately sized and braking capacity of all brakes shall be at least 150% of required braking torque .

xviii) Wire ropes

Hoisting rope shall conform to IS: 2266. Ropes shall be steel wire with fibre core construction.

xix) Rope drum

Drum shall be designed for single layer of ropes only. The diameter of the drum, lead angle and grooving shall be as per IS: 3177. Drum material shall be seamless pipe to ASTM A106 or Fabricated rolled section to IS 2062(latest).

xx) Codes and standards

The design, construction and performance testing of TG hall EOT crane and their associated equipment and accessories shall comply with all currently applicable Statutes, Regulations and the Safety Codes in the locality where the equipment will be installed. These shall also conform to the latest codes/standards as noted below:



IS: 807	:	Code of Practice for Design, Manufacture, Erection and Testing (Structural Portion) of Cranes and Hoists.
IS: 3177	:	Code of Practice for Design of Overhead Travelling Cranes and Gantry Cranes other than Steel Works Cranes.
IS: 1835	:	Steel Wires for Ropes.
IS: 2266	:	Steel Wire Ropes for General Engineering Purposes.
IS: 3443	:	Crane Rail Sections.
IS: 3815	:	Point Hook with Shanks for General Engineering Purpose.
IS : 5749	:	Forged Ramshorn Hooks.
IS: 325	:	three phase Induction Motors.
IS: 7098	:	XLPE Insulated (Heavy Duty) Electric Cables.
IS: 1554	:	PVC Insulated (Heavy Duty) Electric Cables.

All electrical installation work shall comply with the provisions of Indian Electricity Act and Indian Electricity Rules as amended up to date.

4.7.2 Materials of Construction

i)	Bridge girder	:	Grade B to IS:2062 (latest)
ii)	End carriage	:	Grade B to IS:2062 (latest)
iii)	Lifting hooks	:	IS:3815 (latest) or IS:8160 (latest) and shall be made of steel (EN-3A)
iv)	Sheaves	:	Forged steel
v)	Drum	:	Seamless pipe to ASTM A106 or fabricated rolled section to IS:2062
vi)	Wire rope for main/aux. hoist	:	IS:2266; 6x36 fibre core construction (ungalvanised)
vii)	Lifting beam	:	Fabricated from MS IS:2062
viii)	CT/ LT wheels	:	Forged steel
ix)	Bearings for wheels	:	Antifriction Bearings
x)	Shaft	:	EN 8 or equivalent



- xi) Gear box : Fabricated from IS:2062 plates
- xii) Gears : EN-9
- xiii) Pinions : EN-24

4.7.3 Inspection and Testing

- i) Tests at shop

The QA requirements for manufacturing, inspection and testing of the EOT crane at the shop are indicated in Section- 8 of this specification.

- ii) Tests at site

After assembly and erection of crane at site, the crane shall be subjected to tests as indicated in Section-1 of this Specification.



4.8 ELEVATORS

4.8.1 Scope of Supply and Services

The scope of supply and services for complete supply, installation, testing and commissioning are broadly covered hereunder. These are indicative only and not limited to the following:-

- i) Lift car assembly with suspension ropes, car doors, car sling assembly and accessories.
- ii) Design, supply and construction of lift well structure.
- iii) Landing structure, inter connection with the main structure and landing doors with door guide rails and other accessories.
- iv) Lift machine assembly including electric variable voltage variable frequency (VVVF) three phase induction motor, gearbox and sheave.
- v) Microprocessor based control system for VVVF drive including governing of speed, stopping and starting, leveling devices, safety provisions.
- vi) Complete wiring and traveling cable.
- vii) Governor and governor rope safety gears.
- viii) Counterweight shoes and adopter plates and adjustment of counterweight.
- ix) Car operating panel with directions and position indicator and intercom.
- x) Recessed fluorescent light fitting for illumination level of 100 lux on car floor.
- xi) Provision of automatic rescue device in the lift and emergency light and alarm with inverter back up in the car.
- xii) Landing push boxes with directions and positions indicator at all landings.
- xiii) Spring buffers for car and counterweights.
- xiv) Three pin plug socket with switch on top of the lift car.
- xv) Over load annunciation and alarm.
- xvi) Complete installation including commissioning, testing and PG testing.
- xvii) Storage of materials till handed over to project authorities.
- xviii) Fireman's switch at ground floor lobby.



4.8.2 Design Criteria

Elevators shall be designed based on following criteria:-

- i) Number and type of service :
 - a) Two number passenger- cum- goods elevators (3000 kg capacity), one for each steam generator
 - b) Two number passenger lifts/ elevators (900 kg capacity) in TG hall building, one for each unit.
 - c) One number passenger lift/ elevator (900 kg capacity) in service building.
- ii) Design/construction :
 - a) Latest edition of IS: 14665 (all parts) and specified conditions for electrical equipment.
 - b) Local fire regulations and rules in force and Lifts Act and rules in force.
 - c) Any other equivalent code, subject to purchaser's approval.
- iii) Load carrying capacity : As at (i) above.
- iv) Rated speed : As per IS 14665.
- v) Total travel : As per application requirements.
- vi) Entrance and platform size : As per IS 14665.
- vii) Number of floors to be served : As per application requirements.
- viii) Drive/ motor : Worm geared traction machine driven by VVVF motor. Motors shall be rated for frequent starting, S4 duty class as per IS 4722 with CFD of 40% and 150starts per hour at 50⁰C.
- ix) Position of machine room : Directly above the lift shaft.
- x) Elevator landings for boiler area (subject to purchaser's approval) :
 - a) Ground floor
 - b) Boiler operating
 - c) Burner platforms
 - d) Alternate soot blower levels
 - e) Coal feeder floor
 - f) Drum
 - g) At all regularly operating/ maintenance platforms



- xi) Power supply : Each elevator shall be provided with a separate three phase three wire 415 V feeder of adequate rating.

4.8.3 Construction Requirements

Construction of the elevators shall specifically meet all requirements of the codes indicated and shall have following additional features:

- i) The car shall be provided with chequered plate flooring with heavy timber underlay over steel sheeting and replaceable felt spreading, each 25 mm thick. Car inside enclosure shall be provided with scratch proof SS sheet having moon rock finish.
- ii) Car door construction shall be of hollow metal type with SS sheet on inside. The entrance and landing doors shall conform to IS:14665 Part 1. The landing doors shall have fire resistance of at least one hour. These doors shall also be smoke tight as far as possible.
- iii) The hoist way entrance shall be protected by sliding MS doors in plain finish.
- iv) The elevators shall be provided with digital car position indicator in the car, audio enunciator hall position indicator at all floors, tell tale lights at all floors, battery operated alarm bell and emergency light with suitable battery charger and controls, intercom and overload warning indicator with audio annunciator. The indicators shall be of standard type. Alternatively, the bidder may provide luminous hall buttons and luminous button in car operating panel and digital hall position indicator on all floors.
- v) Automatic rescue device shall be provided for operation on power failure.
- vi) The degree of protection of control panel shall be IP- 52 for pressurized dust proof machine room and IP- 21 for air conditioned machine room.
- vii) Sound reducing material shall be provided below machines in machine room.
- viii) Special corrosion resistant treatment shall be provided on all elevator components. The protective treatment shall be subject to purchaser's approval.

4.8.4 Operational Requirements

- i) The elevators shall have provision of automatic operation with or without operator through illuminated push button station located inside the lift car with option of car switch operation.
- ii) The car and landing doors shall be power operated with facility for automatic opening and closing.



- iii) Two push buttons, one for upward movement and the other for downward movement at each intermediate landing, and one push button at each terminal landing shall be provided in order to call the car.
- iv) Push buttons shall be fixed in the car for holding the doors open for any length of the time required.
- v) The elevators shall be provided with all required interlocks for safety, protection and operation as per IS: 14665.
- vi) Governors and safety gears shall be provided to control the speed of the car/ counter weight.
- vii) Position and call indication shall be provided inside the car, and up/down travel direction indication shall be provided in car and at each landing.

4.8.5 Safety, Inspection and Testing

All materials, fittings, appliances etc. including electronic equipment shall work satisfactorily under normal operating conditions. These shall meet the requirement of safety rules as per latest edition of IS:14665 (Part 3/Section-1).

i) Tests at shop

Sufficient tests and inspection shall be made during manufacture of the equipment/ components to ensure that they comply with relevant standard. The QA requirements for manufacturing and tests etc. are indicated in Section- 8 of this specification.

ii) Tests at site

The elevators shall be subject to various tests and inspection for safety at the site as elaborated in Section- 1 of this specification.



4.9 AIR CONDITIONING SYSTEM

4.9.1 General Description

4.9.1.1 Independent central chilled water type air conditioning plant shall be provided for the following areas:

- i) Main control room area comprising of unit control room, control equipment room, shift in-charge room, engineers room, UPS room, analyzer room etc. as applicable.
- ii) Service building.

4.9.1.2 2x100% capacity DX air conditioning plant shall be provided for ESP & VFD control room building.

4.9.1.3 Split/window air conditioners shall be provided for other areas like small offices, general areas, chemical lab etc. where stringent temperature and humidity control is not required. Suitable air conditioning system shall be provided for other areas/buildings, which are not specifically mentioned above but require air conditioning.

4.9.2 Design Philosophy

4.9.2.1 Climatological data applicable for the plant site and design ambient conditions for air conditioning system shall be as per project specific data³. Typical data is indicated as below:

- i) **Climatological data**

a) Maximum mean temperature ($^{\circ}\text{C}$)	32.5
b) Minimum temperature ($^{\circ}\text{C}$)	17.6
c) Highest extreme	48.3
d) Lowest extreme	-3.9
e) Relative Humidity	
• Maximum	82%
• Minimum	27%
f) Annual Rainfall	490.6mm
g) No. of rainy days in a year	28.5
h) Mean wind speed	6.7 kmph
- ii) **Outside design conditions**

Seasons	Dry bulb temperature ($^{\circ}\text{C}$)	Wet bulb temperature ($^{\circ}\text{C}$)
Summer	43.3	25.8
Monsoon	39	29.9
Winter	5	4.2

³ To be furnished by purchaser.



- 4.9.2.2 All air conditioned areas which are permanently manned shall be maintained at $24^{\circ}\text{C} \pm 1^{\circ}\text{C}$ and relative humidity of $50\% \pm 5\%$. The rooms/areas which are not permanently manned like equipment control rooms shall be maintained at $22^{\circ}\text{C} \pm 1^{\circ}\text{C}$ and relative humidity of $50\% \pm 5\%$.
- 4.9.2.3 Number of fresh air changes per hour shall be minimum 1.5 or minimum $0.45 \text{ m}^3/\text{min}$ per person (16 cfm) whichever is higher.
- 4.9.2.4 Lighting load shall be minimum 25 W/m^2 or actual whichever is higher.
- 4.9.2.5 The occupancy for general/ office area shall be minimum one (1) person per 3 m^2 and for conference room the same shall be one (1) person per 1.5 m^2 . In the control rooms, control, equipment rooms etc., the occupancy shall be minimum one (1) person per 20 m^2 .
- 4.9.2.6 Margins for calculating plant capacity:
- i) 12.5%, 10% & 10% margins on sensible heat, latent heat & overall heat respectively shall be considered while calculating the plant capacity.
 - ii) For winter load calculations, 50% of the equipment load as available in the room shall be considered.
- 4.9.2.7 All the equipments of air conditioning system shall be designed for continuous duty.
- 4.9.2.8 The supply and return air ducts shall be provided with automatic motor-operated fire dampers at locations where ducts pass through floors/ceiling slabs for isolation/ maintenance/ fire-protection purpose. The operation of these automatic dampers shall be interlocked with the fire alarm system and shall also be possible to operate manually from the remote control panel. Required electrical contacts shall be provided in control panel of A/C plant for further wiring up to fire alarm panels.
- 4.9.2.9 Smoke detectors shall be provided in the supply and return air ducts.
- 4.9.2.10 Motor operated valves shall be provided as per system requirement for chilling machines, pumps, cooling towers in order to facilitate remote operation of entire air-conditioning plant and to select standby unit.
- 4.9.2.11 For maintenance of compressors/chilling units, pumps, AHUs (air handling units) etc. chain pulley block of suitable capacity and/or suitable structure shall be provided in the AC plant rooms and AHU rooms.
- 4.9.2.12 For service building, air handling units shall be provided for each floor.



- 4.9.2.13 Design chilled water flow shall not be less than 0.7 m³/h per TR air-conditioning load and design condenser cooling water flow shall not be less than 0.9 m³/h per TR air-conditioning load.
- 4.9.2.14 Coil face area of air handling units shall be designed considering a face velocity of not more than 2.5 m/s.
- 4.9.2.15 Water piping shall be sized for a maximum velocity of 2.5 m/s. However gravity flow/ pump suction line shall be sized for a maximum water velocity of 1.5 m/s.
- 4.9.2.16 The air distribution system shall be sized to have a constant frictional drop along its length and velocity through ducts shall not exceed 7.62 m/s.
- 4.9.2.17 A minimum design margin of 10% shall be considered while sizing AC plant and related equipment like chillers, chilled water pumps and AHUs for each area. Head of the pumps shall take into account 10% margin on friction head.
- 4.9.2.18 For pumps, continuous motor rating (at 50⁰C ambient) shall be at least ten percent (10%) above the maximum load demand of the pump in the entire operating range.
- 4.9.2.19 For fans, compressors and blowers continuous Motor rating (at 50⁰C ambient) shall be at least ten percent (10%) above the maximum load demand of the fan, compressors, blower at the design duty point.
- 4.9.2.20 Wherever belt drives are used the belts shall be sized for 150% of the rated power and there shall be minimum of two belts per drive.
- 4.9.2.21 Noise level within the air conditional space shall be restricted to 35-45 NC level with suitable acoustic attenuation/ duct silencers/ acoustic insulation, etc.
- 4.9.2.22 All GS sheets under air conditioning system shall be hot dip galvanised or spray galvanised unless otherwise specified and minimum zinc deposition shall conform to class 275 of IS:277.
- 4.9.2.23 False ceiling shall be provided 3m above the finished floor level and shall be of non luminous (opaque) type fire resistant material.
- 4.9.2.24 Glass areas exposed to sun shall be provided with Venetian blinds of light colour.
- 4.9.2.25 Gravity louver dampers shall be provided for all exhaust air fans.
- 4.9.2.26 Chilled water pumps shall be insulated with 50 mm thick glass wool slab.



4.9.3 Redundancy of Equipments

Redundancy of various equipments shall be as follows:

- i) Chilling units, chilled water pumps, condenser water pumps and AHUs : 2 x 100% or 3 x 50%
- ii) Condensing units and fresh air units : 2 x 100%
- iii) Cooling towers : 2x100%
- iv) Window and split air conditioners : 2 x 100% or 3x50%

4.9.4 Equipment Description

AC plant shall comprise of compressor with drive motor, condenser, water chiller/evaporator, chilled water pumps, condenser water pumps, cooling tower, air handling unit and other accessories such as expansion tanks, steel structure, supporting frames, vibration isolators, insulation, piping, valves, instrumentation, control panel, etc. The sizing calculations for all the equipments shall be furnished by the bidder and shall be subject to approval of the purchaser

4.9.4.1 Chilling unit/ condensing unit

- i) Compressor
 - Type : a) For plant capacity upto 200 TR, compressors shall be of reciprocating water cooled type. Two or more machines shall be provided for plant capacity between 100 TR and 200 TR. The compressors shall be of either open type or semi-hermetic type with load/ un-load and automatic capacity control (minimum 3 steps).
b) For plant capacity of 200TR and above, the compressor shall be screw type.
 - Capacity : Minimum capacity shall be suitable for the identified/selected evaporating temperature and condensing temperature and same shall be indicated.
 - Type of drive : Motor driven, through direct/V-belt
 - Accessories : High /low pressure cutouts, oil pressure switches, relief valves, pressure gauges at each stage, lube oil/control oil pressure gauges, suction and discharge stop valves, muffler, crank case heaters, oil filters, magnetic oil separators, temperature indicators for lube oil/ heaters, oil level indicators, safety thermostat for crank case heater, vibration isolators, safety guard for V-belt drive etc.
 - Vibration isolators : Steel spring/ neoprene rubber cushy foot/ neoprene serrated rubber pad type with isolation efficiency not less than 85%.



ii) Condenser

- Type : Water cooled, shell and tube type with refrigerant on shell side and water on tube side.
- Capacity : To match with respective compressor and to provide atleast 2⁰C sub-cooling. To store full charge of refrigerant.
- Design fouling Factor : Not less than 0.0002 (in MKS units)
- Shell material : Mild steel (IS:2062)
- Tube material : Replaceable seamless copper
- Fin material : Copper
- Accessories : Purge and drain connections, relief valves, liquid line shut-off valves, refrigerant filling charging, flow switches, Isolating valves, Pressure & temperature indicators at inlet and outlet etc.
- Refrigerant : R-22/R-134A
- Steel structure : The complete condensing/ chilling unit shall be mounted on steel structure and shall be provided with necessary vibration isolators

iii) Chiller

- Type : Shell and tube type with refrigerant on shell side and water on tube side.
- Superheating : At least 2⁰C
- Design fouling factor : Minimum 0.0001 (MKS units)
- Capacity : To match with respective plant capacity.
- Shell material : Mild steel (IS : 2062)
- Tube material : Replaceable seamless finned copper
- Fin material : Aluminium
- Accessories : Purge and drain connections, isolating valves, flow switches, pressure & temperature indicators at inlet and outlet, anti-freeze thermostats, thermostatic expansion valve or float assembly as applicable, pilot solenoid valve, relief valves, operating thermostats for capacity control, supporting frame etc.
- Steel structure : The complete condensing/ chilling unit shall be mounted on steel structure and shall be provided with necessary vibration isolators.



4.9.4.2 Air handling unit (AHU)

- i) Each AHU shall consist of casing, fan impeller section, cooling coil section, damper section, steel frame with vibration isolators (minimum efficiency of 85%) for the complete AHU, isolation dampers at the suction and discharge of each AHU, pre-filter at the suction and fine filters (micro-vee type) in the discharge of each individual AHU, absolute (HEPA type) filters in individual discharge of all AHU's of control room, control equipment room, computer, programmer rooms etc and heater section in the common discharge of AHUs.
- ii) The casing of AHUs shall be of double skin construction. Double skin sandwich panels (inside and outside) shall be fabricated using minimum 16g (1.6 mm) galvanized steel, with 25mm thick polyurethane insulation of minimum 40kg/m³ density in between. Reinforcing by 16g galvanized steel hat-channel shall be used to give structural strength.
- iii) Face and bypass dampers (for DX type plant) of opposed blade type shall be provided. Dampers shall be made of 16 gauge G.S. sheet metal (class 275 of IS:277). The area of the bypass section shall be minimum 30% of the coil face area. Damper operating linkage and the operating motor shall be located outside the casing.
- iv) Cooling coil shall be of seamless copper tubes with aluminium fins and shall be provided with suitable drains and vents connections.
- v) All filter plenum shall be provided with a walking platform inside the plenum chamber for filter cleaning purpose. Inspection door shall be provided at the plenum chamber and a removable type ladder shall be attached to plenum.
- vi) Fan impellers
 - a) Fan impeller : Forward/ backward curved blade & centrifugal type.
 - b) Impeller material : Mild steel spray galvanised with minimum zinc deposition conforming to Class 275 of IS:277.
 - c) Fan bearings : Self aligning type, permanently lubricated, heavy duty with a design life of 10,000 operating hours.
 - d) Critical speed : First critical speed of rotating assembly shall be atleast 25% above the operating speed.
 - e) Drive : Motor driven with removable belt guard.
- vii) Pan humidifier of suitable capacity shall be provided for each AHU.



4.9.4.3 Cooling towers

- i) Type : Induced draft, cross or counter flow type.
- ii) Capacity : 110% of rated capacity of each cooling water pump.
- iii) Material of body and sump tank : FRP
- iv) Fan : Cast aluminium / FRP propeller type and multi-blade aerofoil construction with adjustable pitch.
- v) Fill : Non combustible PVC or equivalent of light grey, cream or white colour.
- vi) Louvers : FRP/ PVC/ Aluminium.
- vii) Nozzles : Brass with chrome plating/polypropylene.
- viii) Eliminators : In removable sections to reduce the drift loss to 0.2% of water flow.
- ix) Supporting structure : Mild steel with spray galvanisation or epoxy painting.
- x) Strainer at water outlet : Plate strainer made of GI /SS wire mesh of 16 gauge.
- xi) Bird screen : 25 mm square made of GI/SS wire mesh of 16 gauge.
- xii) Ladder : Hot dip galvanised steel ladder for each tower.
- xiii) Distribution pipe : Galvanised MS pipe.
- xiv) Accessories :
 - a) Drain connection with isolation valve
 - b) Make up connection with ball - float valve, back up gate valve and a bypass with a gate valve for manual operation.
 - c) Overflow connection
 - d) Equalizing connection to connect sump of all the towers wherever applicable.
 - e) Access door in louvers / fan deck.

4.9.4.4 Window type air conditioners

- i) The equipment assembly shall be designed as a self-contained unit. It shall include a prime source of refrigeration, dehumidification, means of circulating and cleaning and filtering the air and shall have the provision to ventilate and/or exhausting and heating. The unit shall be suitable for continuous operation.



- ii) The external casing shall be heavy gauge GS sheet weather proof with corrosion resistant primer and finished in backed enamel paint. Cleanable air filter of dry type shall be provided. The compressor shall be hermetically sealed reciprocating type or scroll type of reputed approved make. Motor shall be protected by overload relay. The condenser shall be air-cooled type with copper tubes and external fins. Evaporator shall be D.X. type with copper tubes and external fins.
- iii) Units shall be complete with electrically operated built in adjustable thermostat which cycles the compressor ON & OFF. It shall also be complete with four directional deflector vanes, internal insulation, moisture removing arrangement, factory fitted internal wiring with relays, contactors, running and starting capacitors, ventilation and exhaust openings, selector switch, front decorative panel, electrical cable not less than 3 metres, three pin plug, any frame work for supporting and installation etc.

4.9.4.5 Split air conditioner

Each split air conditioners shall complete with compressor, condenser, air handling unit, cooling coil, humidification package, filters and vibration isolation pads, control and instruments etc.

The evaporator unit shall be horizontally/ vertically/ floor mounted type as required and constructed of galvanised steel sheet of thickness not less than 18 gauge. It shall be suitable for indoor installation and shall have provision for draining out condensate water. The fan shall be of centrifugal type made of heavy gauge aluminium designed for low noise operation. The cooling coil section shall consist of copper tubes with aluminium fins to provide efficient heat transfer between tubes and fins. Air filters for the blower suction shall be of synthetic washable type provided. Coil filters shall not be acceptable

The condensing unit shall be supplied in weather proof heavy gauge enclosure suitable for outdoor installation. Each unit shall comprise of 2 or 3 independent hermetically/ semi-hermetically sealed compressor units together with associated air cooled condensers, refrigerant tubing and electrical system so that if one compressor unit is down, the other compressors can remain in service. The condenser tubes shall be of copper having extended aluminium fins. The compressor shall be easily accessible during running of the unit.

4.9.4.6 Electric heaters

The electric heaters shall be of electric strip type and shall be complete with requisite contactors, air stat control, thermostats, humidistat, heater box, insulation etc. Heaters shall be provided in ducting common to all AHUs.



4.9.5 Balance Equipment Specification

4.9.5.1 Centrifugal pumps

- i) Type : Horizontal centrifugal, axially split type casing pump
- ii) Impeller : Closed type
- iii) Material of construction :
 - a) Casing : 2% Ni Cast Iron : IS:210 Gr. FG-260
 - b) Impeller : Bronze IS:318 Gr-2
 - c) Wearing rings : Bronze
 - d) Shaft : SS 410
 - e) Shaft sleeve : SS 316
 - f) Shaft sealing arrangement : Mechanical seal
 - g) Base Plate : Carbon steel as per IS:2062
 - h) Speed : Maximum 1500 rpm

The design of the pumps shall conform to IS 5120. The pumps shall have stable rising head capacity characteristic towards shut off. The pumps shall be capable of developing the required total head at rated capacity for continuous operation. The impellers shall be of non overloading type. Pumps of particular category shall be identical and shall be suitable for parallel operation. The shut off head of the pumps shall be at least 20% higher than the rated head for better operation.

4.9.5.2 Piping and fittings

- i) Piping for chilled water and condenser water : Heavy grade-IS:1239 for pipes upto 150 NB and IS:3589 for pipes beyond 200 NB with a minimum thickness of 6mm.
- ii) Drain piping : Same as (a) above and galvanised as per IS:4736.
- iii) Refrigerant piping : Seamless steel tubes conforming heavy grade IS:1239 or copper tubes as per IS:2501 (copper material as per IS:191 hard copper grade).



- iv) Fittings : The steel fittings shall conform to ASTM A234 Gr WPB for sizes 65 NB and above. For sizes 50 NB and below, the material shall conform to ASTM A-105.

For pipe sizes above 350 NB, fabricated fittings from sheets of adequate thickness may be used. The bend radius in case of mitre bends shall be minimum 1.5 times the nominal pipe diameter and angle between two adjacent sections shall not be more than 22.5 deg and shall be as per BS:2633/BS:534.

Fittings, flanges and pipe joints of refrigerant piping shall conform to ANSI B31.5.

4.9.5.3 Valves

- i) Valves shall have full size port and suitable for horizontal and as well as vertical installation. All valves shall be provided with locking arrangement.
- ii) Valves for regulating duty shall be of globe type suitable for controlling throughout its lift.
- iii) Manual gear operators shall be provided for valves of size 350 NB and above.
- iv) All valves with rising stem shall have position indicators.
- v) The refrigerant line valves shall have steel or brass body with TEFLON gland packing. The construction of disc shall be either globe or angle type. The valve seat shall have white metal lining or equivalent.
- vi) All water line valves shall be of cast Iron body for sizes 65 NB and above conforming to IS: 780 and gun metal construction for sizes less than 65NB conforming to IS:778.

4.9.5.4 Air filters

- A) Pre filter shall be provided at the suction of each AHUs and suction of each fresh air fan.
 - i) Filter medium
 - a) Fibrous material (extruded polyethylene) or felt filter fabric; Dry type with element of 5 ply construction for fabric type.
 - b) V-fold galvanized wire mesh inter spaced with a flat layer of galvanized wire mesh for metallic type pre-filters.



- ii) Frame
GI sheet (minimum 18 gauge thick) or aluminium alloy of (minimum 16 gauge) supported by galvanised steel wire mesh of 10 mm Square with handles.
 - iii) Other requirements
 - a) Suitable aluminium spacers be provided for uniform air flow;
 - b) Casing shall be provided with neoprene sponge rubber sealing.
 - c) Capable of being cleaned by water flushing.
 - d) Density of filter medium shall increase in the direction of air flow in case of metallic filter.
 - iv) Efficiency
Average arrestance of 65 - 80 % when tested in accordance with BS:6540/ASHRAE – 52 - 76.
 - v) Minimum thickness : 50 mm for fabric type.
 - vi) Face velocity : Not more than 2.5 m/s.
 - vii) Pressure drop
Initial pressure drop shall not exceed 5.0 mmwc at rated flow and final pressure drop shall not exceed 7.5 mmwc.
- B) Fine filters (micro vee type) shall be provided at the discharge of each individual AHU and at the discharge of each fresh air fan.
- i) Construction : By pleating a continuous sheet of filter medium into closely spaced plates separated by heavy corrugated aluminium spacers.
 - ii) Frame : Aluminium alloy of (minimum 16 gauge conforming to IS:737)
 - iii) Other requirements : a) A neoprene sponge rubber sealing shall be provided on either face of the filter frame.
b) Capable of being cleaned by air or water flushing.
 - iv) Efficiency : Average arrestance of 80-90% when tested in accordance with BS:6540/ASHRAE–52-76.
 - v) Minimum thickness : 150 mm or 300 mm.
 - vi) Face velocity : Not more than 1.2 m/s for 150 mm and not more than 2.4 m/s for 300 mm.
 - vii) Pressure drop : Initial pressure drop shall not exceed 10 mmwc at rated flow and final pressure drop shall not exceed 25 mmwc.



- C) Absolute filter / Hepa filter shall be provided at the discharge of each individual AHU feeding to computer rooms, programmer rooms, control room and control equipment room in central control building.
- i) Media : 100% sub-microscopic glass fibres.
 - ii) Frame : Aluminium alloy of (minimum 16 gauge conforming to IS: 737) with handles.
 - iii) Other requirements : A neoprene sponge rubber sealing shall be provided on either face of the filter frame.
 - iv) Efficiency : 99.97 % down to 0.3 micron when tested in accordance with BS: 3928 (Sodium flame test)/FED-209B.
 - v) Minimum thickness : 300 mm
 - vi) Face velocity : Not more than 1.2 m/s.
 - vii) Pressure drop : Initial pressure drop shall not exceed 25 mmwc at rated flow and final pressure drop shall not exceed 75 mmwc.

4.9.6 Low Pressure Air Distribution System

- i) Material of air distribution system shall be through galvanised steel sheet (Conforming to Class 275 of IS :277) or Aluminium alloy (grade 19000 / SIC or 3100 / NS3 of IS:737)
- ii) Thickness of rectangular ducts shall be as follows :

Larger dimension of duct (mm)	Thickness of sheet(mm)	GI Thickness of aluminium sheet (mm)
up to 750 mm	0.63 (24 G)	0.80
751 to 1500	0.80 (22 G)	1.00
1501 to 2250	1.00 (20 G)	1.50
2251 and above	1.25 (18 G)	1.80
- iii) Duct fabrication and supports
 - a) Duct fabrication shall be as per the latest relevant IS standard.
 - b) The ducts with larger side greater than 2250 mm shall be supported by 15mm MS rods and 50x50x3mm MS double angles while those below 2250 mm shall be supported by 10mm MS rods and 40x40x3 MS angles. The duct supports shall be at a distance of not more than 1200 mm.



- c) Where ever ducts are running outside the building and or at locations where it is not possible to support the ducts from ceiling/floor due to non-availability of the same, the base steel frame/truss work for supporting the ducts between two columns shall be provided.
 - d) Where the sheet metal duct connects to the intake or discharge of fan units a flexible connection of at least 150 mm width shall be provided of closely woven, rubber impregnated double layer asbestos/canvas or neoprene coated fibre glass.
 - e) Wherever duct passes through a wall, the opening between masonry and duct work shall be neatly caulked or sealed to prevent movement of air from one space to the adjoining space.
 - f) Wherever pipe hangers or rods pass through the ducts, light and streamline easement around the same shall be provided to maintain smooth flow of air.
 - g) Access doors shall be provided in the duct work or casing on the both sides of the equipment to be serviced. All access doors shall be of adequate size and shall be lined with substantial felt edging to prevent air leakage.
- iv) Splitters and dampers shall be provided for equipment/area isolation and for proportional volume control of system. The same shall be minimum 16 gauge GS sheet of quadrant type with suitable locking device, mounted outside of duct in accessible position.

4.9.7 Diffusers, Grills and Dampers

- i) Supply air diffusers/grills with volume control dampers shall be provided for all air-conditioned areas.
- ii) Return air diffusers of air conditioned areas shall be without volume control dampers.
- iii) The diffusers/grills shall be of extruded Aluminium of minimum 1.2 mm thick with powder coating for Air Conditioning system
- iv) Supply air grills shall be of double deflection type and return air grills shall be of single deflection type.
- v) All volume control (VC) damper shall be operated by a key from the front of the grills/diffusers and shall be GI sheet.
- vi) The thickness of VC dampers shall be of minimum 20 gauge and thickness of louvers shall be of minimum 26 gauge.



- vii) Suitable vanes shall be provided in the duct collar to have uniform and proper air distribution. Bank of Baffles wherever required shall also be provided.
- viii) Fire dampers shall be motor operated type and shall have fire rating of minimum 120 minutes.
- ix) All plenum chambers of connections to fans, dampers etc shall be constructed in 18 gauge GS sheet and supported on MS angle frames,
- x) All ducting surfaces coming in contact with corrosive fumes or gases shall be painted with three coats of epoxy paint over a coat of suitable primer.

4.9.8 Electrical Works

- i) All auxiliary transformers, switchgear, motor control centres, AC & DC boards, push buttons, local control centre cum control boards etc. as required.
- ii) All electrical motors for driving & actuating purpose.
- iii) All power cabling, jointing, cable trays/supports and clamps and other materials/ works for cable laying and termination of cables.
- iv) Lighting protection and earthing of equipment, laying of main earth mat and risers from earth mat to ground level at selected locations as covered under electrical specification.
- v) Power points for welding and plug joints for inspection hand lamp at various points in the entire plant to facilitate repair and maintenance works.

4.9.9 Thermal and Acoustic Insulation

4.9.9.1 Application

- i) All surfaces to be insulated both thermally and acoustically shall be thoroughly cleaned, dried and an adhesive (CPRX compound of Shalimar tar products or equivalent) be applied @ 1.5 kg/m² on the surface.
- ii) Insulation material (either expanded polystyrene foam or glass wool/ glass fibre or equivalent) shall be struck to the surface. All the joints shall be sealed with bitumen.
- iii) Insulation mass to be covered with 500 gauge polythene sheet with 50 mm overlaps and sealing all joints on hot side.
- iv) Insulation finish of specified type shall be provided thereafter.



- v) For all inspection covers and hatches on equipment, pump casing, valve bodies and flanges (100 mm and above), insulation shall be applied so as to facilitate removal without minimum damage to the insulation by encasing the insulation in 22 gauge aluminium sheet metal boxes which are bolted together around the equipment. However, continuity of the vapour seal between the static and removable portions of the insulation is to be maintained

4.9.9.2 Type of insulation and finish

S. No.	Surface	Insulation material	Insulation form	Thick (mm)	Finish (mm)
i)	Supply & return air duct of AC system	Resin bonded glass wool	Roll /slab	50	F-3
ii)	Refrigerant (Suction and liquid lines)	Expanded polystyrene or mineral wool or resin bonded glass wool	Pipe sec.	75	F-1
iii)	AHU drain pipe	Expanded polystyrene or mineral wool or glass wool	Pipe sec.	25	F-1
iv)	AHU casing and condensate pan	Expanded polystyrene or mineral wool or glass wool	Slab	25	As per manufacturer std.
v)	Chilled water piping valves and specialities	Expanded polystyrene or mineral wool or glass wool	Pipe section	75	F-1
vi)	Chiller	Expanded polystyrene or mineral wool or glass wool	Slab	100	F-1
vii)	Chilled water pumps	Expanded polystyrene or mineral wool or glass wool	Slab	50	F-1
viii)	Expansion tank & associated piping	Expanded polystyrene or mineral wool or glass wool	Slab/ Pipe section	50	F-1



ix)	Acoustic insulation of duct	Glass wool	Slab	25	Refer relevant clause below.
x)	Insulation of hot surfaces	As described for power cycle piping in Section- 4 of this specification.			

4.9.9.3 Specification for insulation shall be as follows:

Insulation material	Code	Thermal conductivity (milli W/cm/ °C)	Density kg/m ³
i) Resin bonded glass wool	IS:8183	0.49 at 50 °C	24 (for thermal insulation) 48 (for acoustic insulation)
ii) Mineral wool	IS:9842	0.43 at 50 °C	81
iii) Expanded polystyrene	IS:4671	0.37 at 50 °C	15

Note : Expanded polystyrene shall be of self extinguishing type (type 2 of IS:4671)

4.9.9.4 The specification for various finishes shall be as follows:

i) Finish F-1

Step-1 Wrapping of poly-bonded Hessain (PBH – to act as vapour seal) on outer surface of insulation with 50 mm overlap stitching and sealing of overlap with synthetic adhesive like CPRX or equivalent compound.

Step-2 The surface then shall be wrapped with 19 mm mesh 24 SWG GI wire netting, butting all the joints and laced down with 22 SWG lacing wire.

Step-3 Sand cement (4:1) plaster shall be applied in two layers totalling to 12.5 mm thick, the second layer being brought to a smooth finish. A water proofing compound shall be added to the cement before its application.

ii) Finish F-2

Step-1 Insulation shall be covered with 500g polythene with 50mm overlap and sealing of overlap with synthetic adhesive like CPRX or equivalent compound.



Step-2 Same as Step-2 of Finish F-1 above.

Step-3 Same as Step-2 of Finish F-1 above.

iii) Finish F-3

Step-1 Same as Step-1 of Finish F-2 above.

Step-2 The polythene shall be covered with 30 gauge aluminium sheet and locking of joints with self-locking screws at a pitch of minimum 100 mm.

iv) Finish F-4

Step-1 Same as Step-1 of Finish-1 above.

Step-2 Same as Step-2 of Finish F-1 above.

Step-3 Same as Step-3 of Finish F-1 above.

Step-4 Application of 3 mm thick coat of water proofing compound 'Shalikote 30' or equivalent and wrapped with fibre glass RP tissue followed by final coat of 3 mm thick water proofing compound 'Shalikote 30' or equivalent over the RP tissue.

Step-5 After the above treatment, 22G aluminium sheet cladding, properly stitched at all joints shall be provided over the external surface.

4.9.9.5 Acoustic insulation

- i) All ducts up to a distance of 5 meters from AHU shall be acoustically lined from inside with 25 mm thick resin bonded glass wool of 48 kg/m³ density and 30 gauge perforated aluminium sheet having 5 mm dia perforation at 8 to 10 mm centre-to-centre distance.
- ii) Fibre glass tissue sheet shall be applied over the outer surface of insulation before applying perforated aluminium sheet. Application of acoustic insulation shall be inline with the requirements specified above.
- iii) In case of all external/exposed insulation, aluminium sheet (22 gauge) cladding, properly stitched all joints need to be provided over the external surface.



4.9.10 Plant Control

4.9.10.1 Design basis

- i) The air conditioning system control system shall be PLC based. Each system (main plant and service building) shall be provided with required I/O modules and two numbers of operator work stations (OWS).
- ii) The basic function of the system shall be to closely control and monitor inside temperature and humidity conditions inside the air-conditioned spaces, to provide remote centralized monitoring & control for various mechanical facilities including sequential start/stop of the whole HVAC System, automatically calculate record and cooling load for each hour/ day/season, to generate maintenance data & alarms, to maintain records of plant operation & energy consumption for varying loads, duty cycling to operate all the equipment including standby equipment for equal duration, automatic startup of standby equipment in case of failure of operating unit and displaying fault alarm status of the tripped unit, activating/ deactivating water valves to startup/stop water flow through chiller/condenser circuit.

4.9.10.2 Water chilling plant control

- i) Microprocessor based controls shall be provided along with facilities to Interface with central PLC and to meet the requirement of all system operations and controls.
- ii) Water chilling unit control system shall be designed to have a constant chilled water outlet from evaporator at all load condition by means of controlling ON-OFF thermostat (one for each compressor) in an automatic manner.
- iii) Water chilling unit shall be equipped with superheat control of water chilling unit through thermostatic expansion valve, which gets its impulse from temperature element connected with suction line after chiller outlet.
- iv) High discharge pressure cut-out and oil pressure (OP) differential cut-out shall be of manual reset type and low pressure cut-out shall be automatic reset type. The OP cut-out shall trip the compressor in case of low oil pressure.
- v) On-off toggle switch to close the liquid refrigerant line solenoid valve shall be provided to shut the compressor by the operation of the operation of low pressure cut-out (after the refrigerant has been pumped to the condenser).
- vi) Switching of crank case heaters shall be interlocked with starting and stopping/tripping of compressor motor. Further, the safety thermostat shall switch off the crank-case heater in the event temperature rises above safe limit.



- vii) Provision shall also be made for the manual restarting of the compressor.
- viii) On-off type anti-freeze thermostats, one for each chiller shall be provided in addition to the controlling on-off thermostat for safety purpose and shall act in the event of failure of on-off thermostat to close the liquid line solenoid valve and also to trip the compressor simultaneously.
- ix) Compressor starting/running shall be interlocked with the flow switches to be provided at the outlet of each chiller and each condenser and as well as with pressure in the inlet of the condensers. In addition closure or open status of various valves through limit switches shall be used for interlock, alarm and control of air conditioning system.
- x) The standby condenser water pumps (if applicable), standby chilled water pumps, standby fresh air fan & standby AHU shall be started automatically when the working equipments are stopped/tripped. Auto/manual selector switches and working/standby selector switches for the pumps/AHU/fresh air fan shall be provided in the panel.
- xi) Closure of fire dampers shall raise an annunciation in the panel.
- xii) Condenser water pumps shall be interlocked with the low level switch in each cooling tower sump and operation of cooling tower fans. High level in the cooling tower shall be annunciated in the panel by means of a separate level switch.

4.9.10.3 Air handling unit

- i) Control of the inside room temperature and humidity shall be by controlling the chilled water flow by means of motor operated three way modulating valve and the modulating valve shall get its signal from the temperature sensor.
- ii) Humidistat located in the return air duct shall actuate the pan humidifier to obtain the desired degree of humidification.
- iii) Separate Humidistat and thermostats shall be provided and interlocked in steps with winter heater / re-heater / strip heaters for monsoon and winter re-heating or heating as the case may be.
- iv) Heater banks shall be interlocked with the running of AHU, temperature of return air, humidity of return air and safety thermostat (Geyserstat located in front of the each heater in the supply air duct)
- v) AHU shall be started either from its local panel or from the main control panel of AC system by means of Remote/Manual selector switches.



- vi) The closure of fire dampers, automatic tripping of AHU fans and fresh air fans shall be interlocked with Bidder's fire Detection System.
- vii) Each AHU shall be provided with temperature indicators and flow indicator in the chilled water piping inlet and outlet to monitor the air-conditioning load of each area.

4.9.10.4 D-X air-conditioning system

- i) The control and interlocks described above for water chilling plant shall be application for this system also.
- ii) Further, the compressor starting/ running shall be interlocked with the flow switches in condenser water circuit and as well as with AHU motors.
- iii) The standby condenser water pumps, fresh air fan & standby AHU shall be started automatically when the working equipments are stopped/ tripped. Auto/ manual selector switches and working/ standby selector switches for the pumps, fresh air fans and AHU shall be provided in the panel.

4.9.10.5 General requirements

- i) Separate emergency local stop push button shall be provided for each pump, compressor, fans etc. of AC system.
- ii) Lamps shall be provided for indicating the status of each pump, compressor, fans etc. of AC system in the main and local panel.
- iii) All the annunciation related to failure of equipments, tripping of equipments, source of failure / reason due to which the equipment is stopped / tripped, low & high limits of parameters such as level, temperature, pressure drop, pressure etc shall be provided for each pump, fan, compressor, AHU etc. in the respective panel.
- iv) Fully wired, twenty percent (20%) spare annunciation windows shall be provided in all the panels.

4.9.11 Painting

- i) All the Equipments shall be protected against external corrosion by providing suitable painting.
- ii) For all the steel surfaces (external) exposed to atmosphere (outdoor installation), a coat of chlorinated rubber based zinc phosphate primer of minimum thickness DFT of 50 microns followed up with undercoat of



chlorinated rubber paint of minimum DFT of 35 microns shall be applied. Then, intermediate coat consisting of one coat of chlorinated rubber based paint pigmented with Titanium di-oxide with minimum DFT of 35 microns and top coat consisting of two coats of chlorinated rubber paint of approved shade and colour with glossy finish and DFT of 70 microns shall be provided. Total DFT of paint system shall not be less than 140 microns.

- iii) For all the steel surfaces (external) inside the building (indoor installation), a coat of red oxide primer of minimum thickness of 35 microns followed up with undercoat of synthetic enamel paint of minimum thickness of 35 microns shall be applied. The top coat shall consist of two coats each of minimum thickness of 35 microns of synthetic enamel paint and thus total thickness shall be minimum 140 micron.

4.9.12 Codes and Standards

The design, manufacture and performance of equipment shall comply with all currently applicable statues, regulations and safety codes in the locality where the equipments are to be installed. Unless otherwise specified, equipment shall conform to the latest applicable Indian or IEC standard or approved equipment standards.

4.9.13 Shop Tests

Sufficient tests and inspection shall be made during manufacture of the equipment/ components to ensure that they comply with relevant standard. The QA requirements for manufacturing and tests etc. are indicated in Section- 8 of this specification.

4.9.14 Site Tests

The tests to be demonstrated at site are included in Section- 1 of this specification.



4.10 VENTILATION SYSTEM

4.10.1 General Description

- i) Evaporative type ventilation system shall be provided for main plant building (other than areas which are air conditioned) as specified below and such air washer units (AWU) shall be distributed along A-row and B-row of the building. Filtered and cooled air from each air washer unit shall be distributed to various areas through diffusers. The main plant building shall be provided with adequate number of roof extractors.
- ii) Unitary air filtration system using water repellent type nylon filters shall be provided for non air conditioned areas of ESP & VFD control buildings as applicable. Unitary air filtration (UAF) units shall be located at top floor of UAF building.
- iii) Mechanical type ventilation system using supply air fans, exhaust air fans or roof exhausters as applicable shall be provided for other miscellaneous areas such as cable vault, electrical switch gear room, battery room, fuel oil pressurization pump house, DG set room, AC plant room, non AC areas of service building, elevator machine rooms, toilets, pantries etc.

4.10.2 Design Philosophy

- i) Climatological data applicable for the plant site and design ambient conditions shall be as per project specific data⁴. Typical data is indicated as at clause 4.9.2 of this Section.
- ii) The capacity of air washers, supply air fans, exhaust air fans/ roof extractors, ducting system shall be designed as per the design philosophy and equipment specification elaborated below. Sizing calculations for all the equipments shall be submitted for approval of purchaser. However, the minimum four (4) number of air washer units shall be supplied for each unit.
- iii) The number of air changes per hour in evaporative/ mechanically ventilated areas shall be as follows:-

Sl. No.	Area	Air changes
a)	For all evaporative type ventilation system	6 to 8
b)	General areas except toilets and pantries	15
c)	Various switchgear/MCC rooms, pump houses, toilets, pantries etc.	20

⁴ To be furnished by purchaser.



- d) Battery rooms etc. where gaseous fumes are generated 30
- iv) In the areas producing lot of heat, the temperature limitation shall be the criteria for evaporative/ mechanical ventilation as indicated below:
- a) Inside dry bulb temperature shall be minimum 5⁰C below the summer design ambient dry bulb during the summer for evaporative cooled areas.
 - b) Inside dry bulb temperature shall be maximum 3⁰C above the summer design ambient dry bulb temperature during summer for mechanically ventilated areas.
 - c) The criterion, which gives higher number of air changes/higher quantity of air in either of the conditions as mentioned above shall be the basis for selecting the required air flow for that area.
- v) All ventilation systems shall be designed for continuous duty and shall operate on 100% fresh air basis.
- vi) All mechanically ventilated areas shall be positively ventilated by means of supply air fans, generally in combination with exhaust fan/ roof extractors. Wherever exhaust fan/ roof extractors are not provided, such as MCC/ switchgear rooms, the pressurised condition shall be maintained with gravity operated backdraft dampers. However, as exception, hazardous areas and fumes/odor generating areas such as toilets shall be negatively ventilated by means of exhaust air fans/ roof exhausters and inlet louvers.
- vii) Supply air fan catering for electrical switchgear/MCC rooms shall be provided with pre-filters and fine filters, while supply air fans for other areas shall be provided with pre-filter only.
- viii) The supply air ducts of evaporative/ UAF type ventilation system shall be provided with automatic (motor operated) fire dampers at the entry to each of the enclosed area like switchgear rooms, cable galleries etc. The operation of these automatic dampers shall be interlocked with the fire alarm system and the operation of these dampers shall also be possible from the control panel remote manually.
- ix) For maintenance of air washer units, chain pulley block of suitable capacity and/or suitable structure shall be provided in the air washer rooms.
- x) Circulating water capacity for air washer units shall be minimum 1 m³/h per 1000 m³/h of air flow while for UAF unit, it shall be minimum 0.6 m³/h per 1000 m³/h of air flow.



- xi) Water piping shall be sized for a maximum velocity of 2.5 m/s. However, gravity flow/ pump suction line shall be sized for a maximum water velocity of 1.5 m/s.
- xii) The air distribution system shall be sized to have a constant frictional drop along its length and air velocity through ducts shall not exceed 12.7 m/s.
- xiii) The AWU and UAF unit shall be designed for a maximum velocity of 2.7 m/s.
- xiv) The AWU shall be designed for at least 90% saturation efficiency.
- xv) For pumps, continuous motor rating (at 50⁰C ambient) shall be at least ten percent (10%) above the maximum load demand of the pump in the entire operating range.
- xvi) For fans and blowers continuous motor rating (at 50⁰C ambient) shall be at least ten percent (10%) above the maximum load demand of the Fan/ blower at the design duty point.
- xvii) For Belt drives, the belts shall be sized for 150% of the rated power and there shall be minimum of two belts per drive.
- xviii) All Carbon steel sheets under evaporative ventilation system shall be hot dip galvanized or spray galvanized unless otherwise specified and minimum zinc deposition shall conform to class 275 of IS:277.
- xix) or calculating friction loss in piping system, WILLIAM & HAZEN formula shall be used with C - value as 100.
- xx) Supply air fans, exhaust air fans and roof ventilators/ extractors of each area shall be provided with their local starter panel.
- xxi) Supply air fans catering the ventilation requirements of various electrical areas (e.g. switchgear/ MCC rooms) shall be fitted with both pre-filter and fine filters, whereas for other areas supply air fan shall be fitted with pre filter only.

4.10.3 Redundancy of Equipments

- i) Pumps for each air washer unit/ unitary air filtration system shall be 2 x 100% or 3 x 50% capacity.
- ii) Fans for each air washer unit/ unitary air filtration system shall be 2x50% capacity.



4.10.4 Equipment Description

4.10.4.1 Air washer unit

- i) Each air washer unit (evaporative system) shall consist of the various Sections such as air washer chamber / casing, tank, distribution plates, set of metallic/fabric filters at suction, suction louvers, bird screens, water headers, spray nozzle, piping, valves, drift eliminators, pumps, fans, necessary controls and instrumentation, and all other required accessories.
- ii) The air washer chamber casing shall be RCC or fabricated from MS sheet as the case may be. The sheet metal air washer chamber casing shall be fabricated from 10 SWG black M.S. sheet with adequate stiffeners etc. and various sections shall be bolted through gaskets to avoid leakage of water. The inside of casing shall be protected by spray galvanization or by three coats of epoxy painting.
- iii) The air washer tank shall be fabricated from MS plate of minimum 6 mm thick and inside and outside surface of the casing and tank shall be spray galvanized. Minimum depth of the tank shall be 600 mm. Tank construction shall be such that the suction screen can be replaced while the unit is operating. Tank shall be provided with overflow, drain with valve, float valve makeup connection with a gate valve backup, quick fill connection with globe valve etc. The overflow pipe shall be connected to drain pipe after isolating valve on drain pipe.
- iv) The distribution plate shall be fabricated out of 18 gauge galvanized steel sheet and galvanized steel angle supports with minimum 50% free area.
- v) Air washers shall be of two-bank construction (one uni-flow and the other cross flow). All header and stand pipes shall be galvanized.
- vi) The spray nozzles shall be of brass or bronze with chrome plating and shall be self cleaning type. The pressure drop through the nozzle should be in the range of 1.4 to 2.4 kg/cm² (g).
- vii) The eliminator plates shall be of 24G thick GS sheets class 350 or from 100% virgin PVC of minimum finished thickness of 2 mm. The eliminator section made of GSS shall have minimum six bends. The PVC eliminators shall be UV stabilised using Titanium di-oxide and shall withstand the weathering test as per IS:4892 for 500 hrs. Type test report of the compound testing carried out in any reputed laboratory shall be submitted for approval. All supports, tie rods and space bar shall be of either galvanized steel or PVC construction and shall be complete with suitable drip tray and drain pipe.
- viii) An airtight inspection door of 600mm x 700mm size and a water marine light be provided for each air washer unit.



- ix) Suitable number of brass screen shall be provided in the air washer tank to arrest the dirt entering the circulating water pump suction. Suitable GI grid shall be used inside the screen for reinforcement
- x) The fans shall be of DIDW type for main plant building and SISW / DIDW for and ESP/VFD building.
- xi) Both inside and outside of all the sections of the metal chamber unit shall be spray galvanized to prevent corrosion. The nuts and bolts used for joining the section shall be galvanized. The connection pieces shall have at least two (2) coats of rust inhibiting paint.

4.10.4.2 Unitary air filtration

- i) Each unitary air filtration shall consist of casing, tanks, fans, Distribution plates, moisture eliminator and water repellent type nylon filter with frame and support, header and standpipe with support, spray and flooding type nozzle, screen type suction strainer, pumps, necessary controls and instrumentation, and all other required accessories.
- ii) All equipments, components used in unitary air filtration system shall be in line with the specification requirements stipulated in air washer units above except the fans which may be of SISW type.

4.10.4.3 Centrifugal fans

- i) The casing shall be of welded construction fabricated with heavy gauge galvanized sheet steel or MS sheet with spray galvanisation. In case of spray galvanisation zinc deposition should conform to class 275 of IS:277. The minimum thickness of casing shall be 3 mm. Split casings shall be provided on larger size fans. Casing drain with valves shall be provided wherever required.
- ii) The impeller shall have die-formed backward-curved blades tie welded to the rim and back plate to have a non overloading characteristics of the fan. The impeller along with driven pulley shall be dynamically balanced as per AMCA standard.
- iii) The bearing shall be self aligning, heavy duty ball/ roller or sleeve bearing. They shall be adequately supported, easily accessible and lubricated properly from outside.
- iv) Inlet guard shall be spun to have a smooth contour. Inlet screen, if provided, shall be of galvanized wire mesh of 25 mm square.



- v) Base plate with necessary number of spring type vibration isolators or ribbed neoprene rubber pad or cushy foot mounting shall be provided. The vibration isolators should have a minimum of 70% efficiency.
- vi) The first critical speed of the rotating assembly shall be at least 25% above the opening speed.

4.10.4.4 Axial fans

- i) These fans shall have single piece cast aluminium impeller with blades of aerofoil design.
- ii) The fan casing shall be of heavy gauge sheet steel construction minimum thickness of 3 mm up to a fan diameter of 750 mm, 5 mm for fans with impeller diameter of 750 mm and above and the same shall be spray or hot dip galvanized.
- iii) Necessary rain protection cowl, inlet and outlet cones, bird protection screen, adjustable damper, vibration isolators, back draft dampers etc. shall be provided.
- iv) For impeller diameter above 450 mm, the fan speed shall not exceed 960 rpm (1440 rpm for fans having static pressure of 30 mmwc or above). For impeller diameter 450 mm or below, the fan speed shall not exceed 1400 rpm (2800 rpm for fans having static pressure of 30 mmwc or above). The first critical speed of rotating assembly shall be atleast 25% above the operating speed.

4.10.4.5 Roof ventilators/ extractors

- i) The roof extractors shall be “COWL” type or equivalent and shall be used for buildings of height 7 m and above.
- ii) Impeller shall be of axial flow type, cast aluminium in one piece and casing shall be heavy gauge sheet steel construction of 3 mm thick for impeller upto 750 mm diameter and 5 mm for fans with impeller of diameter 750 and above and the same shall be spray or hot dip galvanized. Access door with locking arrangement shall be provided in the casing.
- iii) The cowl shall be designed for weather protection of the fan also inside of the roof on which the extractor is installed. Galvanised bird screen of 15mm x15mm shall be provided with the cowl. All accessories, steel supports as required shall be provided.
- iv) The speed of the fan shall be limited as per criterion given above for axial fans.



- v) All accessories such as rain protection exhaust hood, transformation piece, vibration isolators etc. as required shall be provided.

4.10.5 Balance Equipment Specification

4.10.5.1 Centrifugal pumps

Centrifugal pumps shall be of horizontal, centrifugal, closed impeller, axially split type. The materials of construction and technical requirements of the pumps shall be as indicated at clause 4.9.5 of this Section.

4.10.5.2 Piping and fittings

- i) Circulating water piping : Heavy grade-IS:1239 or Equivalent upto 150 NB or equivalent and IS:3589 or equivalent for pipes beyond 200 NB with a minimum thickness of 6mm.
- ii) Drain piping : Same as (a) above and galvanised as per IS:4736.
- iii) Fittings : The steel fittings shall conform to ASTM A234 Gr WPB for sizes 65 NB and above. For sizes 50 NB and below, the material shall conform to ASTM A-105.

For pipe sizes above 350 NB, fabricated fittings from sheets of adequate thickness may be used. The bend radius in case of mitre bends shall be minimum 1.5 times the nominal pipe diameter and angle between two adjacent sections shall not be more than 22.5 deg and shall be as per BS:2633/BS:534.

4.10.5.3 Valves

The valves shall comply with the requirements as indicated at clause 4.9.5 of this Section.

4.10.5.4 Air filters

- A) Pre filters
- i) Filter medium
- a) Fibrous material (extruded polyethylene) or felt filter fabric; Dry type with element of 5 ply construction for Fabric type.
- b) V-fold galvanised wire mesh inter spaced with a flat layer of galvanised wire mesh for Metallic type pre-filters.



- ii) Frame
GI sheet (minimum 18 gauge thick) or Aluminium alloy of (minimum 16 gauge) supported by galvanised steel wire mesh of 10 mm Square with handles.
- iii) Other requirements
 - a) Suitable aluminium spacers be provided for uniform air flow;
 - b) Casing shall be provided with neoprene sponge rubber sealing.
 - c) Capable of being cleaned by water flushing.
 - d) Density of filter medium shall increase in the direction of air flow in case of metallic filter.
- iv) Efficiency
Average arrestance of 65 - 80 % when tested in accordance with BS:6540/ASHRAE – 52 - 76.
- v) Minimum thickness : 50 mm for fabric type.
- vi) Face velocity : Not more than 2.5 m/s.
- vii) Pressure drop : Initial pressure drop shall not exceed 5.0 mmwc at rated flow and final pressure drop shall not exceed 7.5 mmwc.

B) Fine Filters (micro vee type)

- i) Construction : By pleating a continuous sheet of filter medium into closely spaced plates separated by heavy corrugated aluminium spacers.
- ii) Frame : Aluminium alloy of (minimum 16 gauge conforming to IS:737) with handles.
- iii) Other requirements :
 - a) A neoprene sponge rubber sealing shall be provided on either face of the filter frame.
 - b) Capable of being cleaned by air or water flushing.
- iv) Efficiency : Average arrestance of 80-90% when tested in accordance with BS:6540/ASHRAE–52-76.
- v) Minimum thickness : 150 mm or 300 mm.
- vi) Face velocity : Not more than 1.2 m/sec for 150 mm and not more than 2.4 m/sec. for 300 mm.



- vii) Pressure drop : Initial pressure drop shall not exceed 10 mmwc at rated flow and final pressure drop shall not exceed 25 mmwc.

4.10.6 Low Pressure Air Distribution System

The low pressure air distribution system including ducts, diffusers, grills and dampers etc. shall comply with the requirements as indicated at clause 4.9.6 of this Section.

4.10.7 Diffusers, Grills and Dampers

- i) Supply air diffusers/grills with volume control dampers shall be provided for all areas provided with evaporative cooling system.
- ii) Exhaust air grills with volume control damper shall be provided for Battery rooms.
- iii) Inlet/exhaust air grills/louvers shall be provided for all negatively pressure ventilated areas. Back draft dampers shall be provided for all areas pressurised under ventilation system.
- iv) The diffusers/grills shall be of powder coated mild steel construction.
- v) Supply air grills shall be of double deflection type.
- vi) All volume control (VC) damper shall be operated by a key from the front of the grills/diffusers and shall be of GI sheet.
- vii) The thickness of frames of diffusers, grills and VC dampers shall be of minimum 20 gauge and thickness of louvers shall be minimum 26 gauge.
- viii) Suitable vanes shall be provided in the duct collar to have uniform and proper air distribution.
- ix) Bank of baffles wherever required shall also be provided.
- x) Fire dampers shall be motor/solenoid operated type and shall have fire rating of minimum 60 minutes.
- xi) All plenum chambers of connections to fans, dampers etc shall be constructed in 18 gauge GS sheet and supported on MS angle frames.
- xii) All ducting surfaces, grills, dampers coming in contact with corrosive fumes or gases shall be painted with three coats of epoxy paint over a coat of suitable primer.



4.10.8 Electrical Works

- i) All auxiliary transformers, switchgear, motor control centres, AC & DC boards, push buttons, local control centre cum control boards etc. as required.
- ii) All electrical motors for driving & actuating purpose.
- iii) All power cabling, jointing, cable trays/supports and clamps and other materials/ works for cable laying and termination of cables.
- iv) Lighting protection and earthing of equipment, laying of main earth mat and risers from earth mat to ground level at selected locations as covered under electrical specification.
- v) Power points for welding and plug joints for inspection hand lamp at various points in the entire plant to facilitate repair and maintenance works.

4.10.9 Thermal and Acoustic Insulation

Type of insulation and type of finish shall be as under:

	Insulation material	Insulation form	Thick (mm)	Finish (mm)
i) Exposed piping and air duct	Resin bonded glass wool	Roll	25	F-4
ii) Acoustic insulation of duct	Glass wool	Slab	25	Refer clause 4.9.9.7 of this Section.

Thermal and acoustic insulation etc. shall comply with the requirements as indicated at clauses 4.9.9.1, 4.9.9.3 to 4.9.9.7 of this Section.

4.10.10 Plant Control

- i) Air washer units shall be started/stopped by initiation from the local panel and the starting/stopping of fans and pumps shall be automatic upon such initiation.
- ii) The operation of the pumps shall be interlocked with the low level of water in the sump. High level of the sump shall be annunciated. The standby pump shall be started automatically when the working pump is tripped.
- iii) Auto/manual selector switches and working/standby selector switches for the pump shall be provided in the panel.
- iv) A selection switch enabling the running of AWU fan or pump alone shall be provided.



- v) Separate emergency local stop push button shall be provided for each pump, fans etc.
- vi) Lamps shall be provided for indicating the status of each pump, fans etc. in the main and local panel.
- vii) All the annunciations related to failure of equipments, tripping of equipments, source of failure/ reason due to which the equipment is stopped/ tripped, low and high limits of parameters such as level, temperature, pressure, pressure drop etc. shall be provided for each pump, fan, AWU etc. in the respective panel.
- viii) Both supply and exhaust fans shall be operated locally.
- ix) Fully wired, twenty percent (20%) spare annunciation windows shall be provided in all the panels.

4.10.11 Painting

- i) All the equipments shall be protected against external corrosion by providing suitable painting.
- ii) The surfaces of stainless steel, galvanised steel, gunmetal, brass, bronze and non-metallic components shall not be applied with any painting. The Bidder shall clean the external surfaces and internal surfaces before Erection by wire brushing and air blowing. The steel surface to be applied with painting shall be thoroughly cleaned before applying painting by brushing, shotblasting etc. as per the agreed procedure.
- iii) For all the steel surfaces (external) exposed to atmosphere (outdoor installation), a coat of chlorinated rubber based zinc phosphate primer of minimum thickness DFT of 50 microns followed up with undercoat of chlorinated rubber paint of minimum DFT of 50 microns shall be applied. Then, intermediate coat consisting of one coat of chlorinated rubber based paint pigmented with titanium di-oxide with minimum DFT of 50 microns and top coat consisting of two coats of chlorinated rubber paint of approved shade and colour with glossy finish and DFT of 100 microns shall be provided. Total DFT of paint system shall not be less than 200 microns.
- iv) For all the steel surfaces inside the building (indoor installation), a coat of red oxide primer of minimum thickness of 50 microns followed up with undercoat of synthetic enamel paint of minimum thickness of 50 microns shall be applied. The top coat shall consist of two coats each of minimum thickness of 50 microns of synthetic enamel paint and thus total thickness shall be minimum 200 micron.



- v) However for all parts coming in contact with acid fumes (in battery rooms), a coat of epoxy resin based zinc phosphate primer of minimum thickness DFT of 100 microns followed up with undercoat of epoxy resin based paint pigmented with Titanium dioxide of minimum DFT of 100 microns shall be applied and a top coat consisting of one coat of epoxy paint of approved shade and colour with glossy finish of minimum DFT of 75 microns.

4.10.12 Codes and Standards

The design, manufacture and performance of equipment shall comply with all currently applicable statues, regulations and safety codes in the locality where the equipments are to be installed. Unless otherwise specified, equipment shall conform to the latest applicable Indian or IEC standard or approved equipment standards.

4.10.13 Shop Tests

Sufficient tests and inspection shall be made during manufacture of the equipment/ components to ensure that they comply with relevant standard. The QA requirements for manufacturing and tests etc. are indicated in Section- 8 of this specification.

4.10.14 Site Tests

The tests to be demonstrated at plant site shall be as indicated in Section-1 of this specification.



4.11 VIBRATION ISOLATION SPRING FOUNDATIONS

4.11.1 General Requirement

Steel helical springs and viscous dampers shall be provided for equipments requiring foundations with vibration isolation system as described elsewhere in the specification.

4.11.2 Material (Design and Supply)

- i) Steel helical springs and viscous dampers shall consist of
 - a) Steel helical spring units and viscous dampers along with viscous liquid including associated auxiliaries for installation of the spring units and dampers like steel shims, adhesive pads etc.
 - b) Frames for pre-stressing of spring elements.
 - c) Suitable hydraulic jack system including electric pumps, high-pressure tubes etc. required for the erection, alignment etc. of the spring units. One set of extra hydraulic jacks and hand operated pumps shall also be provided.
 - d) Any other items which may be required for the pre-stressing, erection, release of pre-stress, alignment and commissioning of the steel helical springs.
- ii) The design the supporting arrangement for any rotating equipment shall be such that the vibration level is maintained as minimum as possible under all operating conditions. Accordingly, respective rotating equipment shall be supported on RCC deck slab which in turn shall rest on vibration isolation unit consisting of steel helical springs and viscous dampers, which in turn shall be supported on RCC supporting structure.
- iii) The spring units shall have stiffness in both vertical and horizontal directions with the horizontal stiffness not less than 50% of vertical stiffness. The stiffness shall be such that the vertical natural frequency of any spring unit at its rated load carrying capacity is not more than 3 Hz.
- iv) The damper units or spring-cum-damper units shall be of viscous type offering velocity proportional damping. The damper units shall be suitable for temperatures ranging from 0 to 50 deg. C. The damping resistance of individual damper units shall be such that the designed damping is provided using reasonable number of units. Damper units shall have damping resistance ranging from 40 kN sec/m to 750 kN sec/m.
- v) The sizes of the spring units, damper units and spring-cum-damper units shall be such that groups of such units can be accommodated on column heads in case of elevated foundations and on pedestals/walls in case of foundations at ground level.



- vi) The steel helical springs and viscous dampers shall be designed for a minimum operating life of 30 years.

4.11.3 Manufacturing and Testing

- i) Complete manufacturing and testing of the steel helical springs and viscous dampers shall be done at the manufacturing shop of the approved sub vendor/supplier. The testing shall be as per the approved QAP.
- ii) The springs shall conform to codes DIN 2089 and DIN 2096. The quality assurance and inspection procedures shall be finalized on the basis of the above codes and the quality plans be drawn accordingly.

4.11.4 Erection, Commissioning and Supervision

Complete erection and commissioning of the steel helical springs and viscous dampers including pre-stressing of elements, placing of elements in position, checking clearances on the shuttering of the RCC top deck, releasing of pre-stress in spring elements, making final adjustments and alignments etc. all shall be done by a specialist supervisor of supplier/ sub vendor trained for this purpose..

4.11.5 Realignment of Spring System

If any realignment of the steel helical springs and viscous dampers is required to be done for aligning the shaft or for any other reasons during the first one year of operation from the date of Commercial Operation of the machine, the same shall be done by the contractor as and when asked for at no extra cost to the Owner.

4.11.6 Acceptance Criteria

Stiffness values shall be checked. The permissible deviations shall be as per DIN 2096.

4.11.7 Codes and Standards

Spring foundation system shall meet the requirement of the standards applicable as under :

IS: 456	Code of practice for plain and reinforced concrete
IS:2974	Code of practice for design and construction of machine foundation
IS:1893	Criteria for earthquake resistant design of structures
DIN: 4024	Machine foundations; Flexible supporting structures for machine with rotating masses
DIN: 2089	Helical compression springs out of round wire and rod : calculation & design



- DIN: 2096 Helical compression springs out of round wire and rod: quality requirements for hot formed compression springs.
- VDI: 2056 Criteria for assessing mechanical vibrations of machine.
- VDI: 2060 Criteria for assessing the state of balance of rotating rigid bodies



STANDARD TECHNICAL SPECIFICATION FOR MAIN PLANT PACKAGE

SECTION- 5

(ELECTRICAL WORKS)

5.1 GENERATOR

One number turbo-generator set with all auxiliary systems and accessories shall be supplied for each unit.

5.1.1 Type

3-phase, horizontal mounted, 2-pole cylindrical rotor type, directly driven by steam turbine running at rated speed conforming to IEC-60034-1, 60034-3 or other equivalent international standards.

5.1.2 Rating

i) Rated Output

500MW (589MVA) or
..... MW (.... MVA)¹
Generator and its excitation system shall have capability to at least match the declared maximum continuous rated output of the associated steam turbine (for the secondary cooling water temperature of 39⁰C)

Also the generator and its excitation system shall be capable of continuous stable operation without any excessive temperature rise at the peak output of the associated steam turbine under VWO and HP heater out condition, etc. as available for the secondary cooling water temperature of 39⁰C.

ii) Power Factor

0.85 (lag)

iii) Terminal voltage

18 to 24 KV

iv) Frequency

50 Hz

v) Speed

3000 rpm

¹ To be indicated by purchaser as applicable



- | | |
|-------------------------|---|
| vi) Short circuit ratio | Not less than 0.48 (without negative tolerance) |
| vii) Efficiency | > 98% |

5.1.3 System of Cooling

- | | |
|--|--|
| i) Stator winding | Closed loop system using demineralised water flowing through the hollow conductors. |
| ii) Rotor winding | Directly cooled by hydrogen |
| iii) Stator core | Cooled by hydrogen flowing through the radial and axial ventilating ducts. |
| iv) Configuration for hydrogen cooling | Generator to be designed for hydrogen pressure as per manufacturer's practice. The shaft mounted propeller type fans on one or both sides to facilitate circulation of hydrogen inside the machine. Hydrogen to be cooled by coolers using demineralised water mounted in the stator body. |

5.1.4 Insulation

- | | |
|---------------------------|---------------|
| Stator and Rotor windings | Class 155 (F) |
|---------------------------|---------------|

5.1.5 Temperature Limits

- | | |
|---|--------------------|
| i) The maximum temperature limits of generator windings : | |
| a) Maximum temperature of stator core (measured by thermometer) | 120° C |
| b) Maximum temperature of stator winding (measured by RTD) | 120° C |
| c) Maximum temperature of rotor winding (measured by Resistance method) | As per IEC-60034-1 |
| d) Maximum temperature at slip rings (measured by thermometer) | 120° C |



- ii) Generator derated capability
(MVA output and stator current)
 - a) When the temperature of cooling water entering hydrogen coolers or the temperature of hydrogen exceeds from rated temperature by 0° to 15°C. Bidder to furnish
 - b) When the temperature of demineralised water at inlet of stator winding exceeds from rated temperature by 0° to 5°C. Bidder to furnish

5.1.6 Operational Requirements

- i) Voltage variation (±) 5% of rated value at rated power and rated power factor.
- ii) Frequency variation (-) 5 to (+) 3% of 50 Hz at rated power and rated power factor.
- iii) Combined voltage and frequency variation 5% (absolute sum)
- iv) Operating range MVA for short duration and time period at 110% rated voltage shall be specified by the bidder.
- v) Power factor variation 0.85 (lag) to 0.95 (lead)
- vi) Operation under unbalanced load Capable of operating continuously with a negative sequence current of 8% of the rated current. The maximum current in any of the phases not to exceed the rated current.
- vii) Operation under unsymmetrical short circuit Capable of withstanding during any transient unsymmetrical short circuit condition, negative sequence current I_2 expressed in per unit of rated current for duration of 't' sec. such that the value of $I_2^2 t$ is not less than eight (8).
- viii) Voltage waveform The voltage waveform shall be approximately close to a pure sine wave under all conditions of loading



- within the tolerance limits specified in the relevant standards. The balanced and residual telephone harmonic factor (THF) to be within limits specified in IEC-60034-1.
- ix) Short circuit withstanding capacity
- Capable of withstanding of 3-phase short circuit at the generator terminals when operating at rated MVA and power factor with 5% over voltage for a period of not less than 3 seconds. However, the generator to be subjected to withstand test as per clause no. 8.7 of IEC-60034-1.
- x) Line charging capability (MVAR)
- Not less than 35% of the rated MVA at zero power factor leading.
- xi) Capacity with one hydrogen cooler out of service
- Capable of delivering at least two third of the rated MVA
- xii) Generator neutral earthing
- Non-effectively earthed neutral system. Neutral to be earthed through a distribution transformer loaded with a resistor.
- xiii) Generator capability diagrams
- Bidder to submit the capabilities of the generator at different p.f. (lead and lag) and also at varying hydrogen pressures, clearly indicating the operating limits.
- xiv) Impulse level and surge protection
- Impulse level as per IEC-60034,Pt.15
- Surge arrester of suitable rating to be provided for the surge protection of the generator winding. The surge capacitors also to be included.
- xv) Harmonics
- Voltage and current harmonics not to exceed the limits as per IEEE-519.

5.1.7 Design and constructional features

i) General

- a) All components to be designed to avoid resonance at any of the frequency in the operating range and their multiples.



ii) Stator Body

- a) Enclosure
To withstand without any residual deformation, any internal hydrogen explosion.
- b) Handling
4 no. of trunions to be provided for handling the stator by means of crane. Bidder to clearly bring out in the proposal, the features provided in the generator body construction to enable generator stator to be lifted/ dragged.
- c) Transportation
The bidder to furnish details of the type of inland transportation (rail or road) of generator stator body upto the project site.
- d) Manholes
At suitable locations with proper sealing arrangements etc. to facilitate the inspection of back of the core, end winding area and terminal connections

iii) Stator Core

- a) Material
High permeability, low loss, cold rolled silicon sheet steel segmental punchings.
- b) Core assembly
Assembled on core bars in an interleaved manner. To rest on flexible support system such that radial and tangential magnetic vibration of the stator core due to electro magnetic loading transmitted to the outer frame is minimum.
- c) End packets
Adequately strengthened to minimise the magnetic vibration due to end leakage flux.

Fastening elements used in generator to be non - magnetic and be used with proper locking arrangement.



iv) Stator Winding

- | | |
|--------------------------|---|
| a) Winding configuration | Stator winding consisting of three phase, double layer, short chorded, bar type winding having two parallel paths. The elementary conductors to be Roebel transposed in the slot portion. |
| b) Winding insulation | Epoxy thermo-setting type and rated for class 155(F). Provided with adequate protection on the winding and slots for avoiding the corona and other surface discharges. |
| c) Ripple springs | To be provided in stator slots. |

v) De-mineralized (DM) Water Headers

- | | |
|-----------------------------------|--|
| a) Inlet and outlet water headers | Shall be of stainless steel |
| b) Insulation | The headers and header connections shall be suitably insulated from the stator body. It shall be possible to measure the insulation resistance of the stator winding after simply removing the outside water pipe connection. It shall also be possible to measure the insulation resistance between the water header and casing after disconnecting the header grounding. |
| c) Connection of bars | High quality heat resistant and high strength teflon (PTFE) hoses. Single pass cooling arrangement shall be preferred. |

vi) Stator Winding Connection and Terminal Bushings

- | | |
|------------|---|
| a) Winding | Star connected. 3 phase and 3 neutral terminals brought out. All stator terminal lead connections inside the generator to be suitably supported to contain vibration. |
|------------|---|



- b) Overhang portion of winding
- Over-hang portion of the stator winding to be suitably braced and supported so as to withstand 3 phase short circuit at its terminals as stipulated in IEC-60034, when the machine is operating at rated MVA, power factor and permissible maximum over voltage.
- c) Bushing housing
- Bushings to be housed in lower part of stator frame in a non-magnetic steel terminal box.
- d) Bushing material
- Porcelain or epoxy based material with non-hygroscopic property. The terminal bushings to be cooled by suitable arrangement with cooling medium/ system envisaged for the generator.
- e) Terminal connectors
- Silver coated copper having octagonal configuration, suitable for connection to the busduct through flexible connectors for which the operating conductor temperature shall be 105⁰C.
- vii) Rotor**
- Machined from a single alloy steel forging to give the required mechanical, metallurgical and magnetic characteristics. Shall have an adequate margin between critical speed and the running speed to ensure smooth running.
- viii) Rotor Winding**
- a) Conductor
- Coils made of hard drawn silver bearing copper.
- b) Insulation
- Epoxy glass based material rated for class 155(F) insulation.
- ix) Retaining Rings and Nuts**
- a) Retaining rings
- Machined from high strength, non-magnetic alloy steel forging, with the material specification 18Mn18Cr, resistant to stress corrosion. Floating type shrunk on the rotor body.



- b) Locking nuts/ snap rings
Made of high strength non-magnetic alloy steel forging to be provided on the retaining rings to prevent any axial movement.
- c) Centering rings
To be mounted at the end of the retaining rings to support it and prevent the movement of rotor winding in the axial direction due to thermal stresses.
- x) Bearings**
- a) Type
Self-aligning type sleeve bearings either mounted on separate pedestals or on the end shields. The bearing housings and bearing shells to be of split construction. The bearing shells to be lined with tin based TG bearing.
- b) Seal
Provided with Labyrinth shaft seals.
- c) Jacking arrangement
The hydrostatic jacking arrangement in line with turbine bearings.
- d) Bearing insulation
At least one of the bearings to be suitably insulated with arrangements to measure the insulation of the generator bearing while the machine is in operation. Insulating material to be non-hygroscopic epoxy glass laminate.
- e) Bearing instrumentation
Redundant pick-ups/ transducers for bearing metal temperature, bearing drain oil temperature.
- xi) Shaft Seals**
- a) Type
Double flow ring type, to be provided at both ends and designed in such a way that minimum oil comes in contact with hydrogen during operation to minimise contamination.
- b) Sealing ring lining
The face of the sealing ring shall be lined with babbitt metal.



- c) Insulation
- The shaft seals and associated piping shall be adequately insulated to prevent circulation of shaft current.
- xii) Hydrogen Coolers**
- a) General
- To be provided with 10% extra tubes. Cooler to be designed for at least 10 Kg/cm² gauge pressure on the gas side irrespective of a lower normal operating casing pressure.
- b) Cooler tubes
- Corrosion resistant with integral fins and arranged in the stator casing to avoid the direct fall of water during leakage, if any, on the winding insulation. Should be possible to clean/ plug the cooler tubes of a section with the machine under operation.
- c) Water pressure in coolers
- Shall be maintained below the operating hydrogen pressure in the generator casing.
- d) Temperature control
- To be provided with necessary control system including temperature sensing elements, control valves and devices. Also provided with adequate number of temperature and pressure gauges on inlet and outlet of cooling water, in case of water cooled machine.
- xiii) Generator drying arrangement**
- Suitable equipments, accessories and controls shall be provided to enable drying out operation of the generator.
- xiv) Instrumentation for temperature measurement**
- a) Temperature detectors
- Thermocouples/ Resistance temperature detectors (RTDs) of duplex 100 ohms platinum, calibrated as per DIN standard and located at points, where highest temperature likely to occur during operation. Simplex type thermo-couples/ RTDs are acceptable with double the nos.



- b) Number and location
- 12 no. detectors, 4 nos. per phase and uniformly distributed along the circumference of the stator and located at the hottest possible zones viz. the point of exit of stator water from winding in a water cooled machine.
 - Detectors for monitoring water temperature of each winding bar in case of water cooled machine.
 - 12 no. detectors for stator core, out of which 6 nos. to be located in the end zones where maximum temperature are expected.
 - 2 no. detectors per hydrogen gas cooler section for measurement of inlet and outlet gas temperature
 - 2 no. detectors per hydrogen cooler section for measurement of inlet and outlet water temperature
 - 2 no. detectors per bearing for measurement of babbitt metal and drain oil temperature
 - Sets of detectors for generator shaft sealing, Hydrogen gas and Stator Water systems required for monitoring the temperature of oil, water and hydrogen at different salient locations in the system.
- c) Termination of RTD leads
- At terminal box after grouping of signals.
- d) Location of Terminal box
- Terminal box to be located at an easily accessible position to enable maintenance / testing of the devices, when the machine is under operation.
- e) Terminal box construction
- Dust and vermin proof with degree of protection of IP 54.



- f) Interface
- All the above temperature measurement devices to be connected to Distributed Digital Control, Monitoring Information System (DDCMIS).
- xv) **On-line water temperature monitoring system for stator winding bars**
- The processor shall be complete with all software and hardware required to detect any abnormalities in the temperature at any given generator operating point and shall be sensitive to generator loads, header water flows, pressure, etc. and shall be possible to exchange information with DDCMIS through suitable protocols
- xvi) **Instrumentation for vibration monitoring system**
- At least 6 nos. of pickups at each end of over-hang portion of the winding to be provided, symmetrically located around the periphery with connection to 'Turbine Supervisory system'. Provision to be made to connect the same to DDCMIS. Bidder to wire up all the pickups to a junction box outside the generator casing.
- xvii) **Instrumentation for liquid leakage detector**
- To be provided at all the low level points inside the generator casing including end shields along with provisions of indication and alarm during leakage of liquid in generator in case of water cooled machine.
- 5.1.8 Transportation :**
- Bidder shall furnish the details regarding transportation to prevent ingress of moisture during transportation and storage.



5.2 GENERATOR AUXILIARY SYSTEMS

The generator auxiliary system comprising of gas system, seal oil system, stator water cooling system and excitation system shall be provided with all accessories.

5.2.1 Gas system

- | | |
|----------------------------------|--|
| i) Description | Each generator to be provided with H ₂ and CO ₂ gas supply system including gas manifolds, CO ₂ heating system, hydrogen pressure regulator, inter-connecting piping, fittings, valves, gauges, thermometers, pressure transmitters and other instruments, control and annunciation panels etc. |
| ii) Requirement of gas cylinders | Requirement for one start-up and one shut-down of a unit plus those required to be connected on manifolds of both the units plus total requirements for 7 (seven) days consumption of both the units to be furnished. |
| iii) Purity | The system to be suitable for purity of hydrogen from 97-99%. |
| iv) Piping and valves | Seamless steel tubes to be used for piping. Valves to be of glandless diaphragm type, wherever possible. |
| v) Purging | During purging, filling and emergency operating conditions, the gases to be expelled to the atmosphere (outside the TG hall) through a manually operated vent valve. |
| vi) Hydrogen safety relief valve | To be provided at hydrogen manifold |
| vii) Hydrogen driers | 2x100% duty to maintain the H ₂ inside the machine dry at operating pressure.

Gas circulation at standstill: To run the gas system for short time shut down of generator for which gas circulation arrangement through drier, piping valves and accessories along with required control equipment shall be provided. |



- viii) Reactivation of desiccant type dryer
- The design of the drier to be such that it is possible to reactivate the drying medium in situ after isolation from the generator casing and connecting it to atmosphere. For controlling the time/ regime of reactivation, suitable thermometers, thermostats, timers etc. with a local control panel to be provided.
- ix) Valve inter-locking
- 3-way valve used along with the drier for interconnecting the H₂ and air line (as applicable) preferably have mechanical inter-locking, such that closing of the H₂ side port is positively ensured before opening of the air side port.
- x) On-line dew point measurement
- On-line dew point monitoring system to be provided across the inlet and outlet lines to the drying system along with alarm/annunciation in case of high moisture content in the generator casing H₂.
- xi) Gas Analyser
- To be provided with thermal conductivity/ gas density based type to continuously analyze the gas discharged from the casing during purging and also analyze samples of the casing H₂ during normal operation.
- The analyzer to measure the gas purity under the following three conditions :
- a) Normal percentage of purity of H₂ in air in the generator casing. Purity range to include a low purity alarm.
 - b) Percentage of H₂ in CO₂ leaving the casing when H₂ is being admitted or expelled.
 - c) Percentage of air in CO₂ leaving the casing when CO₂ is being admitted or expelled.
- xii) Local Control Panel :
- To be provided with all necessary switches, lamps, indicators, power supplies etc. along with the instruments, necessary outputs to DDCMIS.



- xiii) Portable gas analyzer
Similar as detailed above under clause "Gas Analyzer" to be provided for supervision of the gas purging operation.
- xiv) H₂ pressure and purity
To be monitored in DDCMIS and to be annunciated.

5.2.2 Seal Oil System

- i) General
A complete seal oil supply and control system including AC and DC motor operated pump sets, cooler, filters, pressure regulators, oil tanks, de-gasification tanks, regulating and control valves, gauges, thermometers and other instruments, interconnecting piping including hangers and supports, valves and control/annunciation panel complete with all interlocking relays to be provided. Blowers for venting out H₂ gas liberated from oil to be provided suitably mounted at places where such gas accumulation is likely to occur.
- ii) Number of pumps
2x100% AC motor driven pumps. 1 no. 100% DC motor driven pump.
- iii) Pump starting interlock
Auto starting of stand-by seal oil pumps to be interlocked with seal oil pressure.
- iv) Emergency condition
During short time emergency, which may arise due to non-availability of both AC and DC pumps, unit may be tripped and seal oil supply for such coasting down period shall be from a suitable arrangement from lubrication oil system or a damper tank.
- v) Pipes
Seamless steel piping to be used in the system.
- vi) Seal oil pressure
The seal oil pressure to be maintained at a pressure suitably in excess of the generator casing H₂ pressure. The differential pressure to be kept constant, once set at the time of commissioning, at all H₂ pressures and all regimes of generator operation. The pressure regulator or the regulating valve used for the purpose to be of adjustable type.



- The seal oil system to be designed, such that it is possible to run the machine at no load in air medium at a slightly positive air pressure without any modification in the system.
- vii) Oil level gauge
- For alarm/ annunciation of high and low levels, switches to be fitted in the tank and adequate contacts to be provided for annunciation.
- viii) Hydraulic sealing arrangement
- Necessary hydraulic sealing arrangement to be provided in H₂ side oil discharge line, to prevent circulation of gas due to any possible difference of heads developed by fans mounted at the end of the generator rotor.
- ix) Coolers
- 2x100% duty seal oil coolers along with necessary 3-way valves for isolating or bringing one cooler in service to be provided. Coolers to be of shell and tube type suitable for using DM water of condensate quality.
- x) Cooler tube redundancy
- Seal oil coolers to be designed to have 15% excess tube surface area over and above designed tube surface area required for the rated load conditions, while maintaining the design pressure drop on cooling water side.
- xi) Water pressure
- Oil pressure in the cooler to be greater than water pressure under all operating conditions.
- xii) Filters
- Suitable filters of 2x100% duty to be provided. Possible to carry out cleaning and maintenance of any cooler and filter, when the machine is in operation.
- xiii) Temperature/
Flow Measurement
- Temperature gauges and flow meters to be provided at all appropriate locations.
- xiv) Pressure gauges and switches
- Pressure gauges and switches to be provided at least at the following locations:
- At the inlet and outlet of pumps
 - At the outlet of the cooler



- xv) Control and monitoring
- c) At the inlet and outlet of the pressure regulators and filters.
d) At the oil supply header.
- Bidder to offer proven micro-processor/ PLC based controller. System to be controlled from Man Machine Interface and Plant Information System (MMIPIS) as part of turbine control system at unit control room (UCR). In addition to the remote control and monitoring, local control and monitoring for this system to be realized in the local panel mounted near these systems as per manufacturer's standard. Local panel to be provided with all necessary instrumentation and alarms.
- Outputs to be provided for alarm to DDCMIS
- xvi) Remote Recording
- Seal oil differential pressure to be recorded in DDCMIS.

5.2.3 Stator Water Cooling System

- i) General
- Cooling to be provided with a closed loop stator water cooling system. System to include but not be limited to the following:
- a) Primary water tank
- One (1) no. mounted on anti-vibration pads and covered by the generator cladding. The empty space in primary water tank may be filled with N_2 to minimise water evaporation. Bidder to indicate and provide devices to detect, trap, monitor and release the H_2 that leaks in to the stator water cooling system, to a safe place outside the building through suitable safety valves.
- b) Make up water
- Make-up water for primary water system to be tapped-off from condensate extraction pump discharge header (before and after the condensate polisher) and from DM water make-up line to the condenser. The level in the tank to be maintained by means of suitable valves in the make up line.
- c) Water to water heat exchangers
- 2x100% capacity water to water heat exchangers to be designed to accept



- secondary DM water (condensate quality). The system to be so designed that the pressure of primary DM water inside the cooler is always greater than that of secondary DM water (condensate quality). The exchanger to be designed to have 10% excess tube surface area over and above the designed surface area required for the rated load condition, while maintaining the design pressure drop on cooling water side.
- d) Filters
2x100% capacity fine wire mesh filters with magnet bars of unlimited life for removal of all magnetic particles. Permanent magnet bars to be protected by sleeves of stainless steel. Possible to clean easily the ferro-magnetic particles adhering to the magnet bars during capital maintenance.
- e) Circulating water pumps
2x100% capacity AC motor driven. Standby pump to cut in automatically in case the working pump fails or the pressure of circulating water drops below a certain preset value.
- f) De-mineraliser
One (1) mixed bed demineraliser (MBD) of adequate capacity to maintain the required quality of water. MBD to remain continuously in service in order to retain high purity of stator cooling water with its associated electrical resistivity. Bidder to indicate the capacity of MBD necessary to maintain the quality of water at the desired level for a time duration of six (6) months or more. It shall be designed that the MBD could be taken out of service for refilling without untoward effect on the system, which could necessitate load reduction/rejection.
- g) Piping
Set of stainless steel piping including hangers and supports, valves and other fittings for the complete water system.
- ii) Instrumentation
Following minimum instrumentation to be provided :
- a) Set of conductivity meters in the main



water circuit and after the demineraliser.

- b) Set of flow switches (at least 2 nos.) to monitor low distillate condition and flow transmitters / meters for primary water to stator winding and main bushing, make up water etc.
- c) Sets of pressure gauges at the inlet and outlet of stator water filters, differential pressure switches for the filters, differential pressure gauge across stator winding and pressure transmitters as required.
- d) Set of resistance temperature detectors/ indicators for primary water before and after the generator winding, bushing and cooler. Vapour filled temperature detectors shall also be provided to give signals for high temperature
- e) Set of dial type thermometers for cooling water at the inlet and outlet of the cooler.
- f) Water level gauge, transmitters, level switches for high and low level alarms and other accessories for primary water tank.

iii) Control and monitoring

Bidder to offer proven micro-processor/ PLC based controller. System to be controlled from Man Machine Interface and Plant Information System (MMIPIS) as part of turbine control system at Unit Control Room (UCR). In addition to the remote control and monitoring, local control, monitoring and alarms for this system to be realized in the local panel mounted near these systems as per manufacturer's standard. Local panel to be provided with all the necessary instrumentation and alarms.

Outputs to be provided for alarm to DDCMIS



- iv) On-line monitoring System for water quality Required for ensuring a corrosion free operation to be provided along with stator water system.
- v) Stator coolant flow recorder To be monitored in DDCMIS

5.2.4 Generator Excitation System

i) General

- a) The generator shall be provided with 'Static Excitation System' or 'Brushless Excitation System' along with 'Automatic Voltage Regulator' to meet the requirement specified herein. The excitation system offered shall be of proven design and have a satisfactory field service record on machines of similar size and construction incorporating the type of excitation.
- b) Stability studies, both dynamic (long duration, transient) and steady state, shall be carried out to evaluate various parameters of the excitation system, e.g. response time, response ratio, ceiling voltage, loop gains, power system stabilizer (PSS) parameters etc., so as to meet the operational requirements of the grid particularly on loading side as the power station is connected to the grid by long transmission lines.

The purchaser will furnish all information/ data necessary to carry out the stability studies to the contractor at detail engineering stage

- c) The excitation system shall have matching characteristics suitable for satisfactory parallel operation with other generators in the plant
- d) The necessary inputs and interface equipment shall be provided with Generator Excitation and Automatic Voltage Regulator for hooking up with Turbine Automatic Run-up system and Electro Hydraulic Governing System.

ii) Design and Construction

- a) When the generator is subjected to a sudden loss of rated output at rated power factor, the system shall be capable of restoring the voltage within 2% of the nominal preset value within negligible time
- b) The excitation system shall have 2x100% channels including independent AVRs, power converters and controls. The controls shall have two independent controllers, one for each channel with hot stand-by facility. Each shall be equipped for Auto Operation with the facility for selecting either channel in Auto or Manual mode
- c) Each excitation system channel shall be designed to continuously carry at least 110% of the rated machine excitation current at the rated output of the machine and higher currents for short time duty. Short time duty as mentioned above shall be on MCR base as per clause 1.14 of part III in VDE 530. The rated voltage shall be atleast 110% of the machine excitation voltage



- d) Excitation system response time shall be less than 0.5 sec as per IEEE 421 A
- e) Excitation response ratio shall be greater than 2.
- f) Excitation system ceiling voltage shall be greater than 1.5 times rated load excitation voltage
- g) Each excitation system channel shall be capable of supplying without damage to any of the components, the field forcing voltage and current of the system for a period of 10 seconds without exceeding the limits of temperature for rectifier junction and sink, when the equipment starts at normal operating temperature
- h) Rectifier transformer overload protection shall be provided in case of static excitation system.

iii) Automatic Voltage Regulator (AVR)

- a) The excitation system shall be designed in such a manner that due to any fault in AVR firing circuit pulse transformer, rectifying elements in any channel etc. excitation system shall be available with its full capacity. All rectifying elements shall have over voltage and short circuit protection
- b) Two numbers fully equipped automatic channels having independent inputs and automatic changeover shall be provided. Either channel shall be capable of being the main or standby. Either channel shall be capable of being selected as manual also.
- c) Automatic voltage regulators shall be either of solid state based type or microprocessor/ PLC based as per manufacturer's standard and having negligible time delay suitable for a large interconnected system.
- d) Input to AVR shall be through current transformer secondary 5A and voltage transformer secondary 110V phase to phase.
- e) Characteristics
 - Auto control range of generator operation shall be $(\pm)10\%$ in all modes of voltage level adjustments.
 - Frequency range of operation shall be 47.5Hz to 51.5Hz.
 - Accuracy at which generator voltage to be held shall be better than 0.5% generator terminal voltage.
 - Range of transformer drop compensation shall be 0 to 15%.
 - Maximum change in generation voltage when AVR is transferred from auto to manual under all conditions of excitation. shall be less than 0.5%.
 - Manual control range shall be 70% of no load to 110% full load excitation.



f) Technical features -

The AVR shall be provided with minimum following features :

- | | |
|---|--|
| - Maximum and minimum excitation limiter. | To keep field excitation within the specified limit. |
| - Channel reference control | Either motorised rheostats or microprocessor control. |
| - Ramp generation circuit | To enable gradual rise of reference signal applied to the comparator circuit to avoid sudden voltage build up. |
| - Rotor earth fault detection | Two stage rotor earth fault unit for continuous monitoring along with alarm and trip contacts. |
| - Transformer drop compensation | Suitable feedback proportional to transformer drop to be provided for compensation. |
| - Rotor angle limiter | A rotor angle limiter shall be incorporated in the system. This shall enable to keep the angle between the direct axis of the machine and network vector within the set reference value as determined by stability, by adjusting the excitation. |
| - Stator current limiter | The stator current limiter shall act immediately in under-excited range. The time delay in over-excited range shall enable a temporary overloading of the machine. |
| - Rotor Current limiter | The regulator shall act with time delay, so that the regulation dynamics are not impaired in case of a fault. |
| - Voltage/ frequency (V/F) limiter | To limit the ratio of generator voltage and frequency at all operating conditions to such a value that the maximum generator transformer core flux density does not exceed the value specified. |
| - Automatic change-over from Auto-1 to Auto-2 or vice versa | To be possible in case of trouble in the running channel. |



- | | |
|---|---|
| - Automatic change-over from Auto to Manual | Automatic change over shall be possible from Auto to Manual in case of : <ul style="list-style-type: none">- Generator protection circuit operation i.e. after field forcing and over excitation condition with a time delay.- Loss of terminal voltage feedback by way of any of the VT fuse blowing up.- Faulty over excitation condition.- Loss of automatic channel reference signal- Power supply failure in the automatic channel- Manual intervention |
|---|---|

iv) Power system stabilizer (PSS)

- a) The excitation system shall be provided with power system stabilizer for achieving the dynamic stability of the system under most stringent conditions of operation in the phase of disturbance created by short circuits conditions, load rejections, switching on/ off of transmission lines.
- b) The power system stabilizer should have adoptable settings, which should automatically adjust to system reactance. In other words the system should provide automatic and continuous measurement of system reactance and power system stabilizer setting must continually adjust itself for any changes in the system reactance so as to provide required dynamic stability margins.

v) Specific Technical Requirements for Static Excitation System :

- a) General

The excitation system to be provided with the following :

- Rectifier transformer.
- Thyristor convertor alongwith gate firing circuits
- Voltage Regulator (Auto, Manual)
- Field Flashing system along with transformer and rectifier
- Field Circuit Breaker along with field discharge resistor
- Interconnecting cables/ busbars between different equipment / panels of the system.

- b) Rectifier transformer
Type

Indoor, epoxy moulded dry type, 3 phase step down transformer with class F insulation complete with



	flanges and terminal lugs for connection to the generator terminals through isolated phase bus ducts.
Temperature rise	70 ⁰ C over an ambient temperature of 50 ⁰ C.
Fault rating	Withstand through fault current for the time duration equal to de-excitation time of the generator field current for such faults under AVR/ manual operation.
Housing	Sheet steel cubicle
Protection	A set of CTs to be provided in the primary of rectifier transformer for overload protection. Hot spot temperature measurement in each limb of the transformer alongwith indication as well as alarm and trip contacts shall be provided.
c) Power Thyristor Convertor	
Type	Fully controlled three phase, full wave bridge type facilitating fast and high ceiling performance. Suitable to ensure trouble free service of the cells under all fault conditions.
Protection	The thyristors shall be selectively protected against over- loads by ultra high speed fuses. Suitable lamps indication shall also be provided to indicate the defective 'thyristor'.
Gate Firing Circuit	The firing circuit shall have the following essential features : – It shall produce a gate pulse for every thyristor once in a cycle. – It shall be able to shift the gate pulse in the time over a range of about 150 electrical degrees under a signal from the regulator.



– It shall provide a linear relationship between the regulating inputs volts and rectifier output.

– firing circuit shall have negligible time lag.

– it shall fire the thyristors correctly for any situation of input voltage, depression or unbalance coupled with high or low field currents.

Pulse Transformer

There shall be a pulse transformer between the individual gates of the parallel connected thyristors and between the main current circuit and the control circuit.

Their amplitudes shall be depending upon the trigger characteristics, approximately (+) 3 to (+) 20V peak against cathode.

d) Field Flashing

The initial field flashing shall be from the station's 415V auxiliary AC supply. Suitable rectifier filters, etc. required for converting this ac supply to the required DC supply shall be housed in the excitation system cubicle. Suitable protection interlock with desired time delay shall be provided so that when the AC terminal voltage of the generator is built up to the required level for the main excitation rectifier system to take over, the field flashing circuit is switched off.

In case the main excitation system fails to take over after a predetermined time of field flashing, the field breaker should trip automatically. An annunciation for field flashing failure/ main field breaker trip due to field flashing failure shall be incorporated.



All the components of field flashing system shall be continuously rated irrespective of its short time duty requirement so as to guard against any failure in case of its prolonged mal-operation.

e) **Field Application and Suppression Arrangement**

Field breaker : The generator field breaker shall be of DC, multi pole air break type, suitable for operation from local panel and also from DDCMIS/OWS. The breaker shall have arc quenching arrangement for both the main poles as well as the discharge contacts. Breaker shall be designed to carry currents for continuous as well as short time duty of the excitation system. Breaking current capacity of the breaker shall match with the fault level at the output DC bus. Discharge contacts shall be rated to discharge the field energy corresponding to the highest field current which may come during its entire operating range. The breaker shall be complete with control switches, indication lamps, local/ remote selector switch, etc.

Discharge resistor : Non-inductive for quick discharge of inductive energy and thereby controlling the voltage across the field.

Option : Separate breakers for field application and suppression may also be considered if it is manufacturer's standard arrangement.

Interlocks : Suitable interlock shall be provided to prevent closing of the field breaker unless the regulator reference signal is at/ near the minimum setting and minimum machine speed of 95% is attained. Adequate number of normally open and normally closed field circuit breaker auxiliary contact for remote position indication and interlocking with generator and field flashing circuit shall be provided.

vi) **Specific Technical Requirements for Brushless Excitation System :**

a) **General**

The complete equipment shall be mounted on a bed plate and enclosed by suitable exciter cover. The system shall consist of :

- Permanent Magnet Generator (PMG) type pilot exciter.
- Voltage Regulator (AVR, MVR along with rectifier bridges for PMG)
- Field Circuit Breaker along with field discharge resistor
- Rotating rectifier bridges
- Brushless AC Main Exciter



- Complete instrumentation and protection system
- Inter-connecting cables between different components of the system.

b) Pilot Excitation System

- The pilot exciter shall be revolving field, rectifier assembly and excitation control equipment. The rotor shall be magnetized and stabilized by the Manufacturer to give stable magnetisation characteristic during operation.
- The stator winding shall be of class-155(F) insulation or better, suitable for operation at 50⁰C ambient temperature. The machine shall be fitted with fans for self ventilation.
- Converter Assembly of pilot excitation system, thyristor gate firing system and pulse transformer etc. shall be of similar design as specified under static excitation system.

c) Brushless AC Main Exciter

Armature : This shall be of rotating armature, 3-phases, star connected, feeding current to the rotating diodes mounted on the exciter shaft.

Armature core : The armature core shall be made from silicon sheet lamination to reduce eddy losses and shall be suitably varnished on both sides.

Exciter enclosure and support : The exciter shall be totally enclosed, self ventilated, frame supported on the generator foundation having journal bearings.

Heat exchanger : Integrally mounted air to water heat exchangers. The heat exchangers shall be designed for DM water (condensate quality). Sizing criteria for the heat exchanger shall be similar as for generator mounted hydrogen cooler.

Insulation : The stator and rotor winding insulation shall be of class-155(F) with the temperature rise limited to class-130(B) limits of IEC-60034.

Overhang conductor : The armature conductor in the overhang portion shall be adequately held to withstand the electro-dynamic forces during field forcing condition. Rotor winding retaining ring shall be made up of stress corrosion resistant material.

d) Rotating Rectifier Assembly

- The rectifier assembly made of silicon diodes shall be arranged as two distinct rings with opposite polarity diodes on respective rings.
- The diodes shall be connected in a conventional three arm full wave rectifier bridge. Rectifier assembly shall have one complete bridge as redundant. Alternatively a single three phase rectifier bridge having at least one redundant parallel branch in each of the six arms of the bridge may also be considered.



Rectifier assembly shall have same requirements as regards the component features and rating as detailed out for the thyristor assembly.

- Diodes shall be cooled by forced air circulation by means of fans mounted on the main exciter.
 - Each diode shall be provided with a fuse together with visual indication in the event of diode failure.
 - The output from the rectifier shall be fed to the generator field through the bore of the rotor shaft and necessary plug in type of shaft connection. The axial copper connector shall be designed such that it shall be possible to disconnect this connector at the point where the exciter shaft couples to the generator so that, if necessary, the generator and exciter can be tested individually.
- e) Field application and suppression arrangement As detailed out in 'Static Excitation System'
- f) Instrumentation and Protection

The system shall generally include, but not be limited to, the following :

- Suitable twin resistance temperature detectors for measuring hot and cold air temperature of exciter with necessary provisions for protection tripping/interlocks.
- Dial type thermometers for measuring the inlet and outlet temperature of water to the air coolers.
- Pressure gauges at the inlet and outlet of water to air coolers.
- Instruments and devices for the measurement of rotor winding temperature.
- Stroboscope or suitable alternative device for detection of faulty rotating diode element.
- Suitable arrangement for exciter field suppression.

A pair of auxiliary slip rings shall be provided to give access to the rotor circuit allowing an earth fault detector circuit to be connected.

For all alarms in the system, contact shall be taken from the pressure switches temperature switches etc. provided at suitable points. The system shall be provided with transmitters for the indicators/ recorders.



5.3 GENERATOR ISOLATED PHASE BUS DUCTS (IPBD) AND NEUTRAL GROUNDING EQUIPMENT

Generator isolated phase bus duct between generator terminals to generator transformer and tap-off to unit auxiliary transformers shall be provided.

5.3.1 Codes and standards

The design, manufacture, erection, testing and performance of IPBD shall comply with the latest edition including amendments of the following standards.

<u>Standard</u>	<u>Description</u>
IS:2062	Steel for General Purpose Specification
IS:1367	Hot dip galvanized coatings on fasteners
IS:2099	Bushings for alternating voltage above 1000V
IS:13947Part 1	Low voltage switchgear and Control gear.
IS:2544	Porcelain post insulator for voltages above 1000V
IS:2633	Methods of testing uniformity of coating on zinc coated articles
IS:2705	Current transformers
IS:3070 Part III	Lightning Arresters
IS:3151	Earthing Transformers
IS:3156	Voltage Transformers
IS:4759	Hot dip zinc coating on structural steel and allied products
IS:5082	Wrought aluminum and aluminum alloy for electrical purposes.
IS:8084	Interconnecting busbars for AC voltages above 1 kV upto and including 36 kV.
IS:9431	Specification for indoor post insulators of organic material for systems with nominal voltages greater than 1000 volts upto and including 300 kV.
IEEE:32	Neutral Grounding Devices
IEC:60726	Dry type power transformers
C37.20a, 37, 20b, ANSIC37.20	Switchgear assemblies including metal enclosed bus
C37.20c, (IEEE-27)	
ANSI C37.24	Effect of solar radiation on outdoor metal enclosed switchgear
ANSI,C 37.23 (IEEE-298)	Calculating losses in isolated Phase Bus.
BS:3816	Cast epoxide resin insulating material for electrical application at power frequency

5.3.2 General Technical Requirements

- i) The IPBD will serve as an interconnection between generator, and its associated generator transformer banks and unit auxiliary transformers.
- ii) The bus duct will be installed partially indoor and partially outdoor and shall be suitable for hot, humid and tropical atmosphere. However, cubicles for neutral grounding, voltage transformers and surge protection equipment will be installed indoors.



- iii) The portion of the bus duct at the generator end will be subject to vibrations. Bus duct enclosure shall not be bolted with generator. A slit of 10–20 mm shall be kept between enclosure and generator flange. Suitable covering shall be provided on the slit to allow escape of hydrogen and avoid dust entry inside the common chamber.
- iv) The following calculations for main run delta and tap-off run bus duct shall be furnished.
 - a) Temperature rise at rated current considering effect of solar radiation.
 - b) Conductor size
 - c) Guaranteed KW losses in conductor and enclosure
 - d) Supporting span
 - e) Dynamic and static forces transferred to TG foundation.
- v) Generator transformers and unit auxiliary transformers shall be placed on the rail track. The bus duct and supporting structure shall be designed in such a way so as to permit transformers removal, after opening the terminations, but without dismantling bus duct run or supporting structure.

5.3.3 Equipment Description

5.3.3.1 The bus duct shall be of standard size as per IS-8084 and shall be isolated phase, continuous (bonded enclosure), natural air cooled and positive pressure type.

5.3.3.2 The layout of the bus duct and number of flexible, bolted and welded joints shall be provided as per requirement.

5.3.3.3 Technical parameters

i) General

a) Rated maximum Voltage(r.m.s)	To suit generator voltage
b) No. of phases	3
c) Frequency	50 Hz
d) Neutral grounding	Non-effectively grounding
e) Insulation level	
- 1 minute dry power frequency withstand	55 kV
- 10-sec wet power frequency withstand	55 kV
- Impulse withstand (1.2/50 micro second wave)	125kV (peak)
- Creepage distance	480mm (minimum)

ii) Generator Busduct

a) Type	Isolated phase, continuous self cooled, pressurized type
b) Service	Indoor/ Outdoor
c) Rating	



	<u>Continuous</u>	<u>Symmetrical</u> <u>SC kA rms</u>	<u>Momentary</u> <u>peak kA</u>
- Main run	-----As per system requirement-----		
- Delta run		-----do-----	
- Tap-off for UAT, VT and SP Cubicle and NG cubicle		-----do-----	
d) Permissible temperature rise for			
- Bus conductor		55 ⁰ C	
- Bus enclosure		30 ⁰ C	
iii) Current Transformer			
a) Type		Epoxy cast resin, ring type	
b) Service		Indoor	
c) Mounting		Within bus enclosure	
d) Other ratings		Accuracy Class	
- Low forward power relay, acceptance testing, energy accounting, audit meters		0.2	
- Reverse power relay, AVR, EHG and other measurements		0.5	
Note : CTs for energy meters for Energy Accounting and audit purpose shall be located at a point after the generator stator terminals, and before the tap-off to the UATs.			
iv) Lightning arrester			
a) Type		Gapless type for rotating machine protection	
b) Service		Indoor	
c) Rated voltage		As per generator voltage	
d) Nominal discharge		10 KA	
e) Power frequency spark over voltage		Surge protection of the generator having power frequency one minute high potential test voltage at works of 2U+1kV and BIL of 4U + 5 kV (peak), where U is the line to line voltage.	
v) Voltage Transformer			
a) Type		Epoxy cast-resin drawout	
b) Service		Indoor	
c) Rated Voltage		Generator voltage in kV/ $\sqrt{3}$ V	
- Primary		110 / $\sqrt{3}$ V	
- Secondary		110 / $\sqrt{3}$ V	



d) Winding connection		
- Primary	Grounded Wye	
- Secondary	Grounded Wye	
e) Insulation Class	E or better	
f) Over voltage Factor		
- Continuous		1.2
- 30 seconds		1.9
g) Other ratings	<u>Accuracy</u>	<u>VA burden</u>
	<u>Class</u>	
- Protection	3P	100
- Automatic Voltage Regulator (AVR)/ Electro Hydraulic Governor (EHG)/ Synchronization and other measurements	0.5	100
- Acceptance testing, energy accounting and audit meters	0.2	100
vi) Neutral grounding transformers		
a) Type	Cast iron insulated self cooled	
b) Service	Indoor	
c) Phase	Single	
d) Voltage ratio	22 kV/ 220 V	
e) Rated Output	175 kVA	
f) Duty Time rating	5 minutes	
g) Insulation class	Class F or better	
h) Maximum Temperature	90 ⁰ C rise above 50 ⁰ C ambient	
vii) Neutral Grounding Resistor		
a) Type	Grid Type	
b) Material	Punched Stainless Steel	
c) Service	Indoor	
d) Resistance	As per system requirement	
e) Current	-----do-----	
f) Voltage	250 Volt	
g) Duty (Time rating)	5 minutes	
h) Maximum temperature rise	300 ⁰ C above 50 ⁰ C ambient	
viii) Surge Capacitors	0.125 micro-farad/ Phase, 24 kV Class.	

5.3.3.4 The maximum temperature of the bus conductor and enclosure shall be as defined in the technical parameters when operating at maximum ambient temperature and carrying rated current continuously. For outdoor portions the effect of solar radiation shall also be considered. The bidder shall furnish calculation for temperature rise taking effect of solar radiation into consideration.

5.3.3.5 The bus ducts shall be capable of withstanding the mechanical forces and thermal effects of three phase short circuit currents, mentioned in the technical parameters, without any damage, deformation or deterioration of material.

5.3.4 Temperature rise

For continuous operation at rated current under specified site conditions, the temperature rise shall not exceed the limits as defined under technical parameters.

5.3.5 Enclosure

- i) Each phase shall be enclosed in a weather proof, dust tight, non-magnetic metal (aluminum alloy) enclosure. The enclosure shall be designed for welded connection.
- ii) Filtered drain tapping with dual stop cocks shall be provided for drainage of condensate at the lowest point and at such other locations where accumulation of condensate can be expected. In particular a drain valve shall be provided at the lowest point of transformer end termination. The contractor shall be required to add drainage points if required during installation.

5.3.6 Bus Conductor

- i) The Bus Conductor shall be of high conductivity, painted aluminum alloy as per IS:5082 supported on insulators.
- ii) The bus conductor shall be designed for welded connections except at equipment terminations, bolted disconnect links, and bolted flexible.
- iii) Flexible connections shall be provided between bus sections to allow for expansion and contraction of the conductor. Flexible connections shall also be provided at all equipment terminations.
- iv) All contact surfaces shall be silver plated. All connection hardware shall be non-magnetic and shall have high corrosion resistance.

5.3.7 Insulators

- i) Bus support insulators shall be interchangeable, high strength and fine glazed porcelain manufactured by wet process, or high strength cast resin insulators.
- ii) Insulator shall be mounted in such a way so as to permit its easy removal or replacement without disassembly of the bus.
- iii) The conductor shall be fastened on the insulator through fixed and sliding joints so as to allow conductor expansion or contraction without straining the insulator. Positive contact shall be made between end caps of the supporting insulators and the conductors.



- iv) Additional support insulators shall be provided at bend and at tap offs for withstanding all possible forces.

5.3.8 Connections and Terminations

- i) All matching flanges, seal off bushings, gaskets, fittings, hardware and supports required for termination of the bus duct at Generator, Transformers and other equipment shall be furnished under the scope of this specification. Flexible connections both for conductor and enclosure shall be furnished :
 - a) At all equipment termination to take care for misalignment upto 25mm in all directions.
 - b) Between bus duct supported from building steel and that supported by turbine foundation to prevent transmission vibrations.
- ii) The equipment terminal connections shall be readily accessible and shall provide sufficient air gap for safe isolation during electrical testing.
- iii) If the material of bus conductor and that of the equipment terminal is different, then suitable bi-metallic connectors shall be provided by the contractor.
- iv) Seal off bushings shall be provided at the generator end of the bus duct, tap off to PT cubicles and neutral grounding (NG) cubicle.

5.3.9 Grounding

- i) The electrically continuous bus enclosure shall be used as the grounding bus. All parts of the bus enclosure, supporting structure and equipment frames shall be grounded to earthing mat.
- ii) Duplicate bolted type ground pads shall be provided to accommodate 50x10 mm galvanized steel flats, wherever isolated phase bus duct terminates.

5.3.10 Supporting Structure

- i) All supporting structure required for hanging and/or supporting the complete bus duct shall be furnished. These shall include all members, indoor/outdoor posts, bolts, shims, base plates, hangers, brackets, bracings and hardware.
- ii) All bus ducts shall be adequately supported and braced to successfully withstand normal operation, vibrations, thermal expansion, short circuit forces and all specified design loads.
- iii) Supports shall be designed to provide tolerance of 12mm in the horizontal and vertical directions.



- iv) All steel members shall be hot dipped galvanised after fabrication. All hardware shall be of high strength steel with weather resistant finish.
- v) Arrangement of support steel work shall be such as to prevent heating of structures caused by circulating currents.
- vi) Hinges of all inspection covers shall be strapped across with flexible earth connections.

5.3.11 Air pressuring

- i) Air pressurisation of entire bus duct installation shall be provided to keep pressure inside the bus duct 20 to 100mm water column above atmospheric pressure by clean dry air.
- ii) Complete arrangement for pressurisation of bus duct with purchaser's compressed instrument air supply which shall be at 5.0 to 7.0 kg/ cm² shall be provided including equipment for pressure reduction, drying, bus duct internal pressure indication, dust filters control, safety valves and alarms for failure of pressurisation and excessive leakage. Air drying plants shall have 2x100% redundancy. The degree of protection for control panel shall be IP-52.
- iii) To prevent ingress of foreign matter into the bus duct enclosure during plant shut down or maintenance, aluminum end caps shall be provided for the following locations :
 - a) Generator transformer end, and
 - b) Unit auxiliary transformer end
- iv) One feeder of required capacity shall be made available at each control panel which shall house starters and control systems for blowers, heater, solenoid valves etc.

5.3.12 Current Transformers (CTs)

- i) The current transformers shall be epoxy cast-resin, single core ring type conforming to IS:2705. It shall be mounted within the bus duct enclosure and suitable for operation at an ambient temperature existing within the bus duct enclosure which may be in range of 90⁰C to 100⁰C. Mounting arrangement of CT shall be so designed so as to avoid equalising connections between live conductor and CT inner surface.
- ii) CT secondary leads shall be brought out through non-magnetic metallic conduits to a marshalling box (MB) with degree of protection IP-55 (IS:13947 Pt.1). The MB shall be provided with removable aluminum gland plant. The facility for shorting and grounding shall be provided at the terminal blocks.



5.3.13 Voltage Transformers (VTs) and Surge protection (SP) cubicles

- i) The VT cubicles and SP cubicles shall be provided separately for each phase and shall be metalclad, dust and vermin proof, free standing, dead front assemblies housing VTs, surge capacitor, lightning arrester, fuses on LV side of VT etc.
- ii) Each VT and SP cubicle shall have seal off busing at the terminations of tap-off bus duct to cubicle.
- iii) Lightning arrester shall be gapless type, hermetically sealed, connected between line and ground, specifically suitable for generator.
- iv) A discharge counter shall be provided for each lightning arrester. The discharge counter register shall be visible without having to open the compartment door.
- v) Mineral oil filled/ Askarel filled surge capacitor shall not be acceptable.
- vi) The voltage transformer shall be epoxy cast-resin type conforming to IS:3156.
- vii) The voltage transformer along with secondary fuses shall be mounted on draw out type carriage. Suitable guide slots and stops shall be provided to ensure easy withdrawal and positioning. The fixed and draw out contacts of voltage transformer primary shall be tinned or silver plated.
- viii) Marshalling box shall have sufficient number of terminals with 20% spare, to accommodate all VT leads.

5.3.14 Neutral Grounding (NG) Cubicle

- i) The transformer and resistor shall be located in separate cubicles/compartment adjacent to each other. The cubicles shall have hinged access doors capable of being pad locked.
- ii) The neutral grounding transformer shall be cast epoxy resin dry type natural air cooled single phase connected between generator neutral and ground.
- iii) The loading resistor shall be formed of non-aging, corrosion resistant punched stainless steel grid element provided with necessary insulation and designed for indoor service for a temperature rise not exceeding 300⁰C.
- iv) All alarm, protection and indication leads shall be wired up to terminal blocks that shall be mounted in a IP:52 enclosure suitable for flush mounting and having a fully hinged cover with lock.

5.3.15 Cubicle Construction (VT and SP, NG cubicle etc.)

All cubicles shall be fabricated from cold rolled sheet steel for minimum 2mm thick suitably reinforced to ensure structural rigidity. The degree of protection for all indoor cubicle shall be IP:52 except for neutral grounding resistor enclosure which shall be minimum IP:23.



5.3.16 Space heater, Illumination and Grounding

Each cubicle shall be equipped with space heater with thermostat, internal illumination lamp, 240 V AC, 5A receptacle. Ground bus suitable for receiving two (2) numbers of 50x6mm galvanised steel flats shall be provided on each cubicle.

5.3.17 Finish

- i) Except for supporting steel structures which shall be galvanised, all equipment including bus duct enclosure shall be finished with an under coats of high quality primer followed by two coats of synthetic enamel paint which shall have a thickness not less than 50 microns.
- ii) The interior surface finish of bus duct enclosure shall be as per manufacturer's standard. The shade of exterior surface shall be shade RAL 5012 for bus duct and equipment. The shade of interior surface of cubicles shall be glossy white. The identification tag shall be signal red shade ISC 537 or RAL 3001.

5.4 POWER TRANSFORMERS

Three (3) nos. single phase generator transformers and two (2) nos. unit auxiliary transformers for each unit and two (2) nos. station transformers shall be provided. In addition, one (1) no. single phase generator transformer shall be provided as spare.

5.4.1 Codes and Standards

The generator transformers, station transformers and unit auxiliary transformers shall be complete with all accessories and fittings etc. The equipment, materials and service covered by this section shall conform to the following standards :

IS:2026(Part I to IV)	Power transformers
IS:6600/ BS:CP:1010	Guide for loading of oil immersed transformers
IS:335	New insulating oil for transformers and switchgears
IS:3639	Fittings and accessories for power transformers
IS:2099	High voltage porcelain bushings
IS:2705	Current transformers
IS:3347	Dimensions for porcelain transformer bushings
IS:3202	Code of practice for climate proofing of electrical equipment
IS:2147	Degree of protection
IS:2071	Method of high voltage testing
IS:3637	Gas operated relays
IS:1271	Classification of insulating materials for electrical machinery and apparatus in relation to their stability in service
IS:5	Colours for ready mixed points
IS:10028 Part I, II, III	Code of practice for selection, installation and maintenance of transformers.
IS:5561	Electric power connectors
C.B.I.P. publication	Manual on transformers
IEC:60076, Part 7	Power transformers
IS:354	Method of sampling and test for resins for paints
IEC:137	Insulated bushings for alternating voltages above 1000V.
IEC:185	Current transformers.

5.4.2 General Technical Requirements

The transformers shall be capable of remaining in operation at full load for ten (10) minutes after the failure of oil pump or fans without exceeding the winding hot spot temperature of 140°C. The transformer fitted with two coolers, each capable of dissipating 50% of losses at continuous maximum rating shall be capable of remaining in operation for twenty minutes in the event of failure of pump or fans associated with one cooler without exceeding hot spot temperature of 115°C.

5.4.3 Specific Technical Requirements

5.4.3.1 Generator Transformers

- 1) The MVA capacity of the 3 phase bank shall be chosen equivalent to the

maximum MVA capacity of the generator for an ambient temperature of 50⁰C. No reduction in capacity shall be made for the auxiliary load tapped before the generator transformer.

- 2) One (1) no. single phase generator transformer shall be provided as spare and suitably located in the transformer yard.
- 3) The HV phase & neutral and LV bushing shall be provided with bushing type current transformers (CT).

4) Salient features of the Generator Transformer

i) Service	Outdoor
ii) No. of phases	3 Nos. single phase, 2 winding, 200 MVA for each 500MW unit (or ... MVA for ... MW unit) ²
iii) Voltage	HV : 420/ $\sqrt{3}$ kV LV : as per generator terminal voltage
iv) Frequency	50Hz
v) Winding connection	HV : Star (with neutral solidly earthed) LV : Delta
vi) Vector Group	YN d11
vii) Type of cooling	OFAF
viii) Impedance (%)	15 (indicative)
ix) Maximum permissible temperature rise over an ambient of 50 ⁰ C	In top oil : 50 ⁰ C In winding: 55 ⁰ C
x) Cooling equipments	2x50% cooling radiator banks (suitable no. of working fans and one no. stand-by fan and 2x100% oil pumps)
xi) Type of tap changer	Off circuit tap changer (OCTC)
xii) Tapping range	(+)5% to (-)5% in 4 equal steps on HV side
xiii) Short circuit capability	To withstand the rated short circuit at its terminals for three seconds
xiv) Type of insulation	HV : Graded insulated LV : Uniform
xv) System fault level	400kV system : 40/ 50kA ³ for 1 second
xvi) HV neutral earthing	Solidly earthed through a CT with copper bar suitably with bolted isolating link.
xvii) HV terminal details	Out door type oil filled condenser bushing insulators with test taps. Terminal connectors suitable for ACSR conductor.
xviii) HV neutral terminal details	Outdoor type porcelain bushing with all accessories

² To be indicated by purchaser as applicable

³ Fault level to be decided as per system requirement



- | | |
|----------------------------------|--|
| xix) LV terminal details | Outdoor type top cover mounted porcelain-bushing suitable for isolated phase bus duct connections. |
| xx) Phase arrangement on HV side | R, Y, B sequence (from left while viewing from switchyard and towards the power house). |

5.4.3.2 Station Transformers

- 1) Two (2) nos. station transformers of minimum 63/31.5/31.5 MVA capacity for 500MW (orMVA for ...MW)⁴ units shall be provided.
- 2) The HV side and neutral bushings shall be provided with bushing type current transformers (CTs).
- 3) Impedance values of the Station Transformers shall be 9.5 on 40MVA base (with 50%MDBFP). However, the impedance values shall be chosen to ensure the short circuit current to 40kA on the 11kV side including motor contribution under worst loading condition and largest motor driven boiler feed pump (MDBFP) starting requirements.

4) Salient features of the station transformer

- | | |
|--|---|
| i) Service | Outdoor |
| ii) No. of phases | Three (3) phase bank |
| iii) Voltage | HV : 400kV
LV : 11kV |
| iv) Frequency | 50Hz |
| v) Type | 3 Phase, 3 winding (with two secondary windings of equal voltage and MVA rating) |
| vi) Winding connection | HV : Star (with neutral solidly earthed)
LV : Delta (Non-effectively earthed)/
Star (Non-effectively earthed) |
| vii) Vector Group | YNd11 d11 or YN y0 y0 |
| viii) Type of cooling | ONAF (100% rating)/ONAN (60% rating) |
| ix) Maximum permissible temperature rise over an ambient of 50°C | In top oil : 50°C
In winding : 55°C |
| x) Cooling equipments | 2x50% cooling radiator banks (suitable no. of working fans and one no. stand-by fan and 2x100% oil pumps) |
| xi) Type of tap changer | On Load Tap changer (OLTC) |

⁴ To be indicated by purchaser as applicable



xii) Tapping range	(+)10% to (-)10% in 16 equal steps on HV side
xiii) Type of insulation	HV : Graded insulated LV : Uniform
xiv) Maximum fault level	HV : 40/ 50kA ⁵ for 1 second LV : 40 kA for 1 second
xv) Neutral terminal to be brought out	On HV winding
xvi) Short circuit capability	To withstand rated short-circuit at its terminals for 2 seconds.

5.4.3.3 Unit Auxiliary Transformers (UATs)

1) Two (2) nos. unit auxiliary transformers for each unit shall be provided. The capacity of each transformer shall have at least 20% margin over the calculated load requirement. However, minimum capacity of each UAT shall be minimum 25MVA for 500 MW (.....MVA forMW) unit.⁶

2) Salient features of the unit auxiliary transformer

i) Service	Outdoor
ii) No. of phases	Three (3) phase bank
iii) Voltage	HV : as per generator terminal voltage LV : 11kV
iv) Frequency	50Hz
v) Winding connection	HV : Delta LV : Star (Non-effectively earthed)
vi) Vector Group	Dyn1 or Dd0
vii) Type of Cooling	ONAF / ONAN
viii) Cooling equipments	2x50% cooling radiator banks (suitable no. of working fans and one no. stand-by fan)
ix) Maximum permissible temperature rise over an ambient of 50°C	In top oil : 50°C In winding : 55°C
x) Percentage impedance	10 (indicative)
xi) Type of tap changer	On load tap changer (OLTC)
xii) Tapping range	± 10% in 16 equal steps for OLTC
xiii) Type of insulation	HV : Uniform LV : Uniform
xiv) Maximum fault level	LV : 40kA for 1 second
xv) LV neutral earthing	Through Neutral Grounding Resistor

⁵ Fault level to be decided as per system requirement

⁶ To be indicated by purchaser as applicable



- xvi) Short circuit capability To with-stand rated short-circuit at its terminals for a time duration considering the actual duty to which the transformer is subjected depending upon the generator's initial loading and other design parameters under AVR/ manual mode of operation. Calculations for the above duty shall be carried out and the values could be 3 to 5 seconds instead of 2 seconds indicated in I.S.

3) Neutral Bushing Current Transformer

- | | |
|--|--|
| i) Rated Transformation ratio | Standard transformation ratio based on 'UAT rating / 1A' |
| ii) No. of identical cores | 2 |
| iii) Accuracy | PS |
| iv) Short time current, dynamic rating etc | Same as 415V Switchgear |
| v) Purpose | Protection |

5.4.4 Design requirements

i) **Loading Capability**

Continuous operation at rated MVA on any tap with voltage variation of $\pm 10\%$ corresponding to the voltage of the tap and in accordance with IS:6600 shall be possible. All the transformers shall operate at full load for at least ten minutes without exceeding the calculated winding hot spot temperature of 140°C in the event of complete failure of power supply to cooling equipment.

ii) **Flux density**

The flux density of transformers shall not exceed 1.9Wb/m^2 at any tap position with $\pm 10\%$ voltage variation from voltage corresponding to the tap. Transformer shall also withstand following over fluxing conditions on combined voltage and frequency fluctuations:

- 110% for continuous rating.
- 125% for at least one minute.
- 140% for at least five seconds.

The over- fluxing characteristics upto 170% shall be furnished.

5.4.5 Noise Level

The noise level of transformer shall not exceed the values specified in NEMA TR-1.



5.4.6 Insulation Level

The insulation level for the transformer windings and bushings shall be as follows:

Highest system voltage (kV)	Winding			Bushing		
	Rated power frequency withstand voltage (kVrms)	Rated switching Impulse withstand voltage (kVp)	Rated lightning impulse withstand voltage (kVp)	Rated power frequency withstand voltage (kVrms)	Rated switching Impulse withstand voltage (kVp)	Rated lightning impulse withstand voltage (kVp)
3.6	10	-	40	10	-	40
12	28	-	75	28	-	75
24	50	-	125	50	-	170
245	395	-	950	460	-	1050
420 ⁷	-	1050	1300	630	1050	1425

5.4.7 Other Requirements

- i) Generator transformers shall be suitable for back charging. It shall be capable of being charged from HV side and kept charged continuously with no load on the LV side without any adverse impact on the transformer life.
- ii) Two auxiliary power supplies, 415V, three phase, 4 wire shall be drawn from two separate switchgears for the cooler control cabinet and OLTC cubicle. Cooler control equipments shall be divided in two halves, each having one power supply incomer with bus section between two halves.
- iii) Vibration level at rated voltage and frequency shall not be more than 200 microns peak to peak. Average vibration shall not exceed 60 microns peak to peak. Tank stresses shall not exceed 2.0 Kg/mm² at any point on the tank.

5.4.8 Transformer transportation

Nitrogen filled with sufficient number of impact recorders with necessary arrangement to maintain nitrogen pressure during transit and storage.

5.4.9 Fittings for main and OLTC tank - Following fittings shall be provided with provision for remote indication :

- i) Buchholz relay
- ii) Oil surge relay to be provided for OLTC
- iii) Pressure relief device
- iv) Oil temperature indicator
- v) Winding temperature Indicator (WTI)

⁷ Next higher value of insulation may be adopted for Generator Transformer bushing

- vi) Magnetic oil level gauge for main conservator
- vii) Remote WTI
- viii) Oil level gauge
- ix) Remote tap position indicator
- x) One no. oil flow indicator for each pump
- xi) OLTC features:
 - Local control, both manual and electrical
 - Remote electrical control.
 - Safety interlocks and protection

5.4.10 Transformer Oil Centrifuging Plant

One no. mobile transformer oil centrifuging plant shall be provided. It shall be of sufficient capacity suitable for generator transformer with the following features :

- i) The capacity of the transformer oil centrifuging plant shall not be less than 10KLPH and vacuum in three stage degassing plant shall be better than one torr. First stage will be evacuated by a two stage rotary oil sealed pump. Second stage of degassing column will be evacuated by a mechanical booster pump. Third stage of the degassing column will be evacuated by a roots pump. The plant shall be rated for continuous operation. The plant shall be mobile with four (4) wheel pneumatic tyres and suitable for being towed on motorable roads. The plant shall also be supplied along with transformer evacuation system consisting of roots pump backed by a two stage rotary pump. Provision at suitable place in the path of oil being processed shall also be made for connecting an ionic reaction column to be used for the removal of acidity and product of oxidation and ageing in used transformer oil. The ionic reaction column shall also be supplied with the plant. The plant shall be complete with on-line testing instruments and annunciating panel.
- ii)
 - a) Dielectric strength : Suitable for 70kV or better with spark gap of 2.5 mm for 1 minute
 - b) Water content in purified oil : Better than 20 ppm in single pass
 - c) Suspended particles : 1 Micron
 - d) Gas content : 0.1% by volume
 - e) Dissipation factor of oil at 90⁰C after filling into the equipment : 0.05
- iii) The centrifuging plant shall be supplied with the essential testing equipments including but not limited to the following :-
 - a) Neutralization valve or total acidity test set to measure neutralization value of or total acidity content of transformer oil (organic or inorganic) as per IEC 296 and IS 335.



- b) Gas content measuring instrument to measure dissolved gas content in percentage of volume of same sample of transformer oil.
- c) Karl Fischer Apparatus to measure precisely dissolved moisture content in transformer oil.
- d) Inter facial tensiometer to measure the inter facial tension of insulating oil against water under non-equilibrium conditions in dynes/cm.
- e) Relative humidity (RH) and Oil dryness test set to measure accurately water vapor pressure dew point and RH of a sample of insulating oil which in turn shall be used to assess the state of dryness of oil immersed solid insulation.
- f) Electronic vacuum gauge to measure with precision high vacuum inside the tank if new transformer supplied with protected nitrogen blanket while the same is being evacuated for filling of oil.
- g) Dew point meter to measure the dew point of the gas/ air surrounding the insulation of windings inside the transformer tank in order to determine surface mean moisture content of insulation.
- h) Automatic Dissolved Gas Analyzer to extract and measure various gases dissolved in electrical insulating oil of EHV transformers which are in service and also the estimation of hydrocarbon gases present in the layers above the transformer oil.



5.5 11kV & 3.3kV SEGREGATED PHASE BUS DUCTS

The 11kV segregated phase busduct shall be provided for i) between UATs secondary terminals and 11kV unit switchgears ii) between station transformer secondary terminals to 11kV station switchgears. The 3.3kV segregated phase bus duct shall be provided between 11kV/ 3.3kV auxiliary service transformers secondary terminals to 3.3kV unit switchgears.

5.5.1 Codes and standards

The Design, manufacture, erection, testing and performance of segregated phase bus duct shall comply with the latest edition including amendments of the following standards :

IS:226	Structural steel (Standard quality)
IS:737	Specification for wrought aluminum and aluminum alloys, sheet and strip (for engineering purpose).
IS:800	Code of practice for use of structural steel in general building construction.
IS:1367 Part-13	Hot dip galvanised coatings on threaded fasteners.
IS:2099	Bushing for A.C. voltage above 1000 volts.
IS:13947 Part-1	Low voltage switchgear and controlgear
IS:2544	Porcelain post Insulators for system with normal voltage greater than 1000 volts.
IS:2633	Methods of testing uniformity of coating on zinc coated articles
IS:4759	Hot dip zinc coating on structural steel and allied products.
IS:5082	Specification for wrought Aluminum alloys bars, rods, tubes and sections for electrical purposes.
IS:8084	Interconnecting bus bars for A.C. voltage above 1KV upto and including 36KV.
ANSI C-37:23	Metal enclosed bus.
ANSI C-37:24	Effect of Solar radiation on metal enclosed bus.

5.5.2 General Technical Requirements

- i) The bus ducts will serve as interconnections between transformers and switchgears. The technical parameters of 11kV and 3.3kV bus ducts are given below :

	<u>11 kV</u>	<u>3.3 kV</u>
a) Number of phase	3	3
b) Frequency	50 Hz	50 Hz
c) Nominal voltage	11kV	3.3 kV
d) Highest system voltage	12 kV	3.6 kV
e) One minute power frequency withstand voltage (dry and wet)	28 kV	10 kV



f)	Impulse voltage withstand value with 1.2/50 micro-sec wave shape	75 kV	40 kV
g)	Continuous current rating	as required	as required
h)	Short time current rating for 1 second	40kA	40kA
i)	Dynamic current withstand rating	100 kA(peak)	100kA(peak)
j)	Type of cooling	Natural	Natural
k)	Type of bus enclosure	Phase segregated	Phase segregated
l)	Service	Indoor/ Outdoor	Indoor/ Outdoor
m)	Clearance of live parts in air	As per IS	As per IS
	- Phase to phase	---do---	---do---
	- Phase to earth	---do---	---do---
n)	Busbar material	Aluminum alloy	Aluminum alloy
o)	Enclosure and partition material	Aluminum alloy	Aluminum alloy
p)	Minimum thickness of enclosure	3 mm	3 mm
q)	Minimum thickness of partition	2 mm	2 mm
r)	Insulators and bushings		
	- Rated voltage	12 kV	3.6 kV
	- One minute power frequency withstand voltage		
	Dry	35 kV	20kV
	Wet	35 kV	20kV
	- Impulse voltage withstand value with 1.2/50 micro sec. wave shape.	75 kV	40kV
	- Minimum creepage distance	240 mm	130 mm
	- Material of insulator	Porcelain	Porcelain
s)	Size of earthing conductor (mild steel)	65mmx8mm galvanized	65mmx mm galvanized
t)	Design ambient temperature.	50 ⁰ C	50 ⁰ C
u)	Maximum temperature when carrying rated current continuously		
	- Bus conductor:		
	Bolted joints (Plain or tinned)	90 ⁰ C	90 ⁰ C
	Bolted joints (silver plated)	105 ⁰ C	105 ⁰ C
	- Bus duct enclosure	80 ⁰ C	105 ⁰ C
ii)	The bus ducts will be installed partially indoor and partially outdoor and shall be suitable for hot, humid and tropical atmosphere.		
iii)	The maximum temperature of the bus conductor and enclosure shall be as defined in the technical parameters when operating at maximum ambient temperature and carrying rated current continuously. For outdoor portions the effect of solar radiation shall also be considered. The bidder shall furnish calculation for temperature rise taking effect of solar radiation into consideration.		
iv)	The bus ducts shall be capable of withstanding the mechanical forces and thermal effects of three phase short circuit currents, mentioned in the technical parameters, without any damage, deformation or deterioration of material.		

5.5.3 Equipment Description

i) **Bus conductor**

The bus conductor shall be of high conductivity aluminium alloy, adequately supported on insulators to withstand dynamic stress due to the specified short circuit current, without permanent deformation and suitable flexible joints shall be provided wherever required.

ii) **Enclosure**

- a) The bus duct enclosure shall be phase segregated type. The three phases of bus conductors shall be enclosed in a weather and vermin proof, dust-tight enclosure made of Aluminum alloy. Phase barriers made of aluminum alloy shall be provided in the bus ducts for phase segregation. The shape of the enclosure shall preferably be rectangular. All horizontal runs of the bus ducts shall have a suitably sloped enclosure top to prevent retention of water.
- b) Bus duct enclosure shall have a degree of protection conforming to IS : 8084 requirements for water tightness test and air leakage test. Minimum enclosure thickness shall be 3 mm. The bus duct enclosure shall have expansion bellows to take care of temperature changes and vibrations.
- c) At each enclosure joint in the outdoor portion of the bus duct run, a suitable rain hood shall be provided for additional protection against water ingress. The gaskets shall preferably of the jointless type, in case of a joint, the same shall be at bottom.
- d) Opening covered with louvers backed up with removable dust filters and silicagel breather shall be provided at indoor and outdoor portion of bus duct to enable the bus duct enclosure to breathe in a manner so that possibility of condensation and ingress of dust is minimized.
- e) Filtered drain plugs for drainage of condensate and seepage water if any shall be provided at the lowest points and at such location where accumulation of condensate can be expected. These drain plugs shall be located at a suitable place convenient to operate.

iii) **Insulators**

- a) Bus support insulators shall be interchangeable, high creep, high strength and made of fine glazed solid porcelain manufactured by wet process.
- b) The insulators shall be designed and mounted in such a manner so as to facilitate easy inspection, removal and replacement without disturbing the conductor.



iv) Space heaters

The bus ducts shall be provided with adequate number of thermostatically controlled space heaters of adequate capacity to maintain the internal temperature above the dew point to prevent moisture condensation within the bus duct. Space heaters shall be rated for 240V, single phase, 50Hz AC supply.

v) Bus duct support

- a) Bidder shall provide necessary support structures and all hardware structures to support the bus ducts all along its route.
- b) In the indoor portions, the bus ducts shall be supported from floor / roof beams or steel inserts in upper floors. In the outdoor portions, they shall be supported from the ground, by means of steel structures, unless indicated otherwise in the specification drawings.
- c) All hardware shall be galvanised or cadmium plated.

vi) Earthing

A continuous 65x10 mm galvanised mild steel earth bar shall be provided along the entire run of each bus duct. Each section of the bus duct enclosure shall be bonded to this earth bar at least at both ends of the enclosure. The earth bar shall be connected to the main earthing system at its two ends by the contractor.

vii) Connection and termination

- a) All matching flanges, flexible connections, adapter boxes, gaskets, fittings, hardware and support required for termination of the bus duct at transformer and switchgear ends, shall be provided by the Bidder.
- b) Flexible connections at equipment termination shall be able to take care of misalignment upto 25mm in all directions.
- c) The equipment terminal connections shall be easily accessible and shall provide sufficient air gap for safe isolation of equipment during testing.
- d) Suitable bi-metallic connectors shall be provided wherever the material of bus conductor and equipment terminals are different.

viii) Paint and finish

- a) The paints shall consist of one coat of primer followed by one anti-corrosive coat for steel structures. Finally two coats of finishing paint shall be given. The final colour shade shall be BLUE RAL:5012 .
- b) The bus conductor and the inside surface of the enclosure shall be treated with matt black paint for efficient heat dissipation.



5.6 AUXILIARY SERVICE TRANSFORMERS

The auxiliary service transformers shall be provided to obtain the 3.3kV and 415V power supply for main plant area.

- i) The 3.3kV power supply to the unit auxiliaries shall be obtained from 11kV/ 3.3kV auxiliary service transformers.
- ii) The 415V power supply to the unit auxiliaries shall be obtained from 11kV/ 433V or 3.3kV/433V auxiliary service transformers.

5.6.1 Codes and standards

The equipment, materials and service shall conform to the following standards:-

IS:2026 (Part I to IV)	Power Transformers.
IS:6600/BS: CP:1010	Guide for loading of oil immersed transformers
IS:335	New insulating oil for transformers and switchgears
IS:3639	Fittings and accessories for power Transformers
IS:2099	High voltage porcelain bushings
IS:2705	Current transformers
IS:334	Dimensions for porcelain Transformer bushing
IS:3202	Code of practice for Climate proofing of electrical equipment
IS:2147	Degree of protection.
IS:2071	Method of high voltage testing
IS:3637	Gas operated relays.
IS:1271	Classification of insulating materials for Electrical Machinery and apparatus in relation to their stability in service.
IS:5	Colours for ready mixed points.
IS:10028	Code of practice for selection, Installation and maintenance of transformers Part I, II and III
IS:5561	Electric Power connectors
IS: 11171	Dry type transformers
CBIP	Manual on transformers.

5.6.2 Technical Parameters

- i) The transformers shall be provided with delta-connected primary and a star-connected secondary with the star point brought out and resistance earthed for 3.3KV system and solidly earthed for 415V system.
- ii) The transformers shall have following technical parameters :
 - a) Type Two winding
 - b) Service Outdoor (Oil Filled) /
Indoor (Dry type :epoxy cast resin/ resin encapsulated air cooled type)



c) Number of phases	Three		
d) Frequency	50 Hz		
e) Type of cooling	ONAN for oil filled		
f) Ratings	As per system requirement.		
g) Impedance	As per system requirement.		
h) Duty	Continuous		
i) Over load	As per IS:6600		
j) System fault level			
11 kV	40 kA for 1 second		
3.3 kV	40 kA for 1 second		
415V	50 kA for 3 second		
k) Windings	<u>11 kV</u>	<u>3.3 kV</u>	<u>433V</u>
Insulation	-----Uniform-----		
- Power frequency test level (KV rms)	28	10	3
- Basic impulse level (kV peak)	75	40	--
- Highest voltage for each(kV) winding	12	3.6	1.1
l) Earthing	a) 415V : solidly grounded,		
	b) 11kV, 3.3kV : earthed through resistance to limit the current to 300A or high resistance grounding through artificial earthing transformer and earthing resistance		
m) Tap changer	Off circuit tap changer with $\pm 5\%$ in steps of 2.5 % on HV side		
n) Bushing	11 kV	3.3 kV	0.433 kV
- Rated voltage(kV)	12	3.6	1.1
- Basic Impulse level (kVp)	75	40	--
- Wet, dry power withstand voltage(kV)	28	10	3
- Minimum creepage distance (mm)	As per relevant IEC/ IS		
- Mounting (mm)	Tank / Transformer body		



- o) Terminal details
 - High Voltage (3.3kV and 11 kV) Busduct/ Cable
 - 433V phase and neutral Busduct/ Cable box
However, non-segregated busduct for transformers rated 1000 KVA and above shall be provided.
- iii) Temperature rise over an ambient of 50°C
 - a) Out-door transformers :
 - In top oil (measured by thermometer): 50°C
 - In winding (measured by resistance): 55°C
 - b) In-door transformers :
 - In winding (by resistance method) 90°C or lower as permissible for class of insulation offered
- iv) Class of insulation
 - F or better (for dry type transformers)
 - A or better (for oil filled transformers)
- v) Noise level at rated voltage and frequency As per NEMA Pub TR-1

5.6.3 Neutral Grounding Resistor

- i) Resistance (ohm) As per requirements
- ii) Rated current and duration 300A for 10 seconds
- iii) Application Grounding of 11kV and 3.3 kV system
- iv) Service Outdoor
- v) Resistor materials Punched stainless steel grid element
- vi) Maximum allowable temperature rise 350°C



vii)	Mounting	12kV grade insulator (for 11kV)/ 3.6kV grade insulator (for 3.3 kV)
viii)	Enclosure degree of protection	IP-33 as per IS-2147
ix)	Terminal bushing rated voltage	12kV grade insulator (for 11kV)/ 3.6kV grade insulator (for 3.3 kV)
	Rated current	300 A
	Basic Impulse level	75kVp (for 11kV)/ 20kVp (for 3.3kV)
	Quantity	two each
	Mounting	Roof of enclosure
x)	Terminal details	
	- To transformer neutral	Copper flat of minimum 50 mm x 6 mm
	- To earth	Through Galvanized steel flat of size 50mm x 10mm

5.6.4 Performance

Fault conditions :

- The transformer and all accessories including CT's etc. shall be capable of withstanding for two (2) seconds without any damage on external short circuit at bushing terminal.
- The flux density at normal voltage and frequency shall be such that flux density in any part of the core and yoke at rated MVA, rated Voltage and frequency, with 10% voltage variation from the voltage corresponding to the tap, shall not exceed 1.9 wb/m².
- Transformers shall accept without injurious heating, combined voltage and frequency fluctuations which produce an overfluxing condition of 120% for one (1) minute.
- Noise level when energized at normal voltage and frequency shall not exceed, when measured under standard conditions as per NEMA standard publication TR-1, the values specified are as below:
 - For 3 MVA transformers - 63 db
 - For less than 2 MVA Transformers - 60 db

5.6.5 Painting

All steel surfaces shall be thoroughly cleaned by sand blasting or chemical agents as required, to produce a smooth surface free of scales, grease and rust. The internal surfaces in contact with insulating oil shall be painted with heat resistant insulating varnish which shall not react with and be soluble in the insulating liquid used. The external surfaces, after cleaning, shall be given a coat of high quality red oxide or yellow chromate primer followed by filler coats. All supporting structures and hardware shall be hot dip galvanized.

The transformer shall be finished with two coats of battle ship grey (IS Shade # 632) synthetic enamel paint unless otherwise specified.

5.6.6 Detailed description

i) Tank

The transformer tank and cover shall be fabricated from high grade low carbon plate steel of tested quality. The tank and the cover shall be of welded construction. At least two inspection openings, one at each end of the tank with welded flange(s) and bolted cover(s) shall be provided on the tank cover. The inspection opening(s) shall be of sufficient size to afford easy access to the lower ends of the bushings, earth connection etc.

ii) Under Carriage

- a) The transformer tank shall be supported on steel structure with detachable forged steel flanged wheel suitable for moving the transformer completely filled with oil. Rail gauge shall be 1676 mm in both directions. Flanged wheels shall be spaced accordingly. Wheels shall be provided with suitable bearings, which will resist rust and corrosion and shall be equipped with fittings for lubrication. It shall be possible to swivel the wheels in two directions, at right angles to or parallel to the main axis of the transformers.
- b) Jacking pads shall be provided on the transformer. It shall be possible to change the direction of the wheels through 90 degree when the transformer is lifted on jacks to permit movement of the transformer both in longitudinal and transverse directions.
- c) Suitable hydraulic (synchronous) jacks (4 nos.) for lifting the transformer shall be supplied.

iii) Conservator tank

- a) The conservator tank shall have adequate capacity to accommodate oil preservation system and volumetric expansion of the total cold oil volume in the transformer and cooling equipment for a change in temperature from minimum ambient temperature as per IS.
- b) The conservator shall be fitted with magnetic oil level gauge with two independent low level electrically insulated alarm contacts.
- c) Each conservator vessel/ air bag shall be fitted with a silica gel filter breather.

iv) Pressure relief device and explosion vent

- a) For all transformers, the conventional diaphragm type of explosion vent shall be provided.

- b) In addition to the explosion vent, pressure relief device shall be provided for transformers rated 2 MVA and above which shall be of sufficient size for rapid release of any pressure that may be generated within the tank and which may result in damage of the equipment.
- c) An extension pipe shall be fitted above the device such as to direct the major flow of ejected oil down wards and shall be fitted so as to permit its removal without disturbing the device or its flange fixings.

v) Buchholz relay

A double float type Buchholz relay conforming to IS:3637 shall be provided. All gas evolved in the transformer shall collect in this relay. The relay shall be provided with a test cock suitable for a flexible pipe connection for checking its operation. A copper tube shall be connected from the gas collector to a valve located about 1200 mm above ground level to facilitate sampling with the transformer in service. The device shall be provided with two electrically independent potential free contacts, one for alarm on gas accumulation and the other for tripping on sudden rise of pressure.

vi) Temperature indicator

- a) Oil temperature indicator :

All transformers shall be provided with a 150 mm dial type thermometer for top oil temperature indication. The thermometer shall have adjustable, electrically independent ungrounded alarm and trip contacts, maximum reading pointer and resetting device and shall be mounted in the Marshalling Box.

- b) Winding temperature indicator :

A device for measuring the hot spot temperature of the winding shall be provided. The accuracy class of winding temperature indicator shall be $\pm 2^{\circ}\text{C}$ or better.

vii) Earthing terminals

Two earthing pads suitable for connecting 50 x 10 mm mild steel flat shall be provided at positions close to the two diagonally opposite bottom corners of tank. These grounding terminals shall be suitable for bolted connection.

viii) Core

- a) The core shall be constructed from high grade non-aging, cold rolled grain oriented silicon steel laminations.



- b) The insulation of core to bolts and core to clamp plates shall be able to withstand a voltage of 2kV RMS for one (1) minute.
- c) Eye and lugs shall be provided for lifting the core.

ix) Windings

- a) The conductors shall be electrolytic grade copper free from scale and burrs.
- b) Tappings shall be so arranged as to preserve the magnetic balance of transformers at all voltage ratios.

x) Insulating oil

- a) The new insulating oil, before pouring into the transformer (i.e. 10% topping up oil) shall conform to the requirements of IS:335. No inhibitors shall be used in the oil.
- b) The oil samples taken from the transformer at site shall conform to the requirement of IS:1866 and the value for various parameters shall not lie very close to the limiting values specified in IS:1866 with respect to the reconditioning of oil.
- c) 5% extra oil shall be supplied for topping up, in non returnable containers suitable for outdoor storage.

xi) Oil preservations system

- a) The transformers rated below 7.5MVA shall be provided with conventional single compartment conservator with dry air filling the space above the oil.
- b) The transformers rated 7.5MVA and above shall be provided with diaphragm sealing type (air bag) oil preservation arrangement in the conservator to prevent oxidation and contamination of oil due to contact with atmospheric air.

xii) Valves

- a) Valves shall be of gun metal/ cast steel up to 50 mm size and of cast iron bodies with gunmetal fittings for sizes above 50 mm.
- b) Each transformer shall be provided with atleast following valves on the tank:
 - Drain valves so located as to completely drain the tank.
 - Two filter valves on diagonally opposite corners of 50 mm size.



- Oil sampling valves not less than 8 mm at top and bottom of main tanks.
- One 15 mm air release plug.
- Valves between radiators and tanks.

5.6.7 Transformer cooling system

Tank mounted radiators banks shall have bolted flanged connections and pipe extensions to permit withdrawal of transformer tank without disturbing the radiators. Flexible joints shall be provided in the interconnecting pipes (unless otherwise approved) to facilitate erection and dismantling and reduce transfer of vibrations from tank to radiator. The interconnecting pipes shall be provided with drain plug and air release vents.

5.6.8 Terminal arrangement

i) Bushings

- a) The bushing shall conform to the requirements of IS:2099 and IS:3347.
- b) All transformer bushings shall be of porcelain (for oil filled)/ epoxy (for dry type).
- c) The neutral terminal of 433V winding shall be brought out on a bushing along with the 433V phase terminal to form a 4 wire system for the 433V. Neutral CTs shall be located in the lead coming out of the winding and location of these CTs shall not be inside the tank.
- d) The neutral terminal of secondary shall be brought out through an outdoor bushing. Further this neutral terminal shall be connected by a copper flat of size 50 mm x 6 mm, which shall be brought down upto 100 mm above ground. The copper flat shall be insulated and supported from the tank body.

ii) Cable boxes

- a) Wherever cable connections are specified, suitable cable boxes shall be provided and shall be air insulated.
- b) Cable boxes shall have drilled gland plate of adequate size to receive cables and to allow easy termination.
- c) Removable drilled gland planes shall be provided in the cable boxes.
- d) The additional supports for the cable boxes shall be galvanised iron.
- e) The contractor shall provide earthing terminals on the cable box, to suit 50mmx6 mm GI flat.



- iii) Bus duct
 - a) Wherever Bus duct termination is specified a flanged throat or equivalent-connection shall be provided for termination of bus duct enclosure. The winding termination shall be outdoor type bushing. The material of the bus duct termination arrangement of the transformer shall be nonmagnetic. The bus duct may be either phase-segregated or non-segregated.
 - b) Tolerance permissible for the height of terminals and bus duct flange location specified for bus duct termination over ground level is ± 5 mm. Contractor has to ensure that radiator, conservator and explosion vent do not obstruct the path of the bus-ducts.

5.6.9 Current Transformers

- i) The protection CT's on neutral of transformers and neutral grounding transformers shall be bushing mounted. It shall be possible to remove the turret mounted CT's from the transformer tank without removing the tank cover.
- ii) The current transformers shall be comply with IS:2705.
- iii) All secondary leads of bushing mounted CT's shall be brought to a terminal box near each bushing and then wired upto transformer marshalling box.
- iv) The CT terminals shall have shorting facility.

5.6.10 Marshalling box

- i) A sheet steel weather, vermin and dust proof marshalling box shall be furnished. The sheet steel used shall be at least 2.0 mm (CRCA) thick. The box shall be free standing floor mounted/tank mounted type and have a sloping roof. The degree of protection shall be IP-55 in accordance with IS:2147.
- ii) The marshalling box shall have a glazed door of suitable size for convenience of temperature indicators reading.
- iii) All incoming cables shall enter the marshalling box from the bottom.

5.6.11 Off-circuit tap changer (OCTC)

- i) The tap change switch shall be three phase, hand operated for simultaneous switching of similar taps on the three phases by operating on external hand wheel.
- ii) Arrangement shall be made for securing and pad-locking the tap changer in any of the working positions, and it shall not be possible for setting or padlocking it in any intermediate position. An indicating device shall be provided to show the tap in use.



5.6.12 Fittings

The following fittings (wherever applicable) shall be provided with all the transformers, unless mentioned specifically otherwise.

- a) Conservator with oil filling hole and cap, isolating valve, drain valve, vent valve and oil preservation equipment as specified.
- b) Magnetic oil level gauge with low level alarm contacts. It shall be welded to the tank.
- c) Prismatic glass oil level gauge.
- d) Pressure relief device and Explosion Vent.
- e) Air release plug.
- f) Inspection opening and covers
- g) Bushing with metal parts and gaskets to suit the termination arrangement specified in Technical Parameters.
- h) Oil temperature indicator with alarm and trip contacts.
- i) Winding temperature indicator (s) with alarm and trip contacts.
- j) Covers, lifting eyes, transformer lifting lugs, jacking pads, towing holes, core and winding lifting lugs, supporting structure, foundation bolts etc.
- k) Protected type Mercury or alcohol in glass thermometer.
- l) Bottom and top filter valves with threaded male adopters, bottom sampling valve and drain valve.
- m) Rating and diaphragm plates.
- n) Off circuit tap changing equipment.
- o) Marshalling Box
- p) Cable Boxes
- q) Buchholz Relay
- r) Dehydrating filter breather
- s) Bushing current transformers (wherever applicable)
- t) Earthing terminals.
- u) Remote WTI. It shall not be repeater dial of local WTI
- v) Radiator
- w) Wheels
- x) Oil
- y) V/v schedule plate
- z) Rain hoods for B/z relay, MOG and PRV



5.7 MOTORS

All the 11kV, 3.3kV and 415V motors required for unit auxiliaries shall be provided.

5.7.1 Codes and Standards

All the motors shall conform to the following standards :

IS:325, IEC:60034	Three phase induction motors
IS:996, IEC:60034	Single phase AC motors
IS:3177, IEC600:34	Crane duty motors
IS:4722	DC motors

5.7.2 General Requirements

i) All the motors shall be suitable for an ambient temperature of 50⁰C and relative humidity of 95%. The motors shall be suitable for operation in a highly polluted environment

ii) Voltage and Frequency variations : All motors shall be suitable for following variations

Frequency variation	(+) 3% and (-)5%
Voltage variation	a. (±) 6% for 11kV/ 3.3 kV b. (±) 10% for 415 V
Combined variation of voltage and frequency.	10% (absolute sum)

iii) The voltage level for motors shall be as follows

1) Upto 200 KW	415V
2) Above 200 kW and upto 1500 kW	3.3 kV
3) Above 1500 kW	11 kV

iv) Fault level

1) 11 kV and 3.3 kV	40kA for 1 second
2) 415V	50kA for 3 second
3) 220V DC	25kA for 1 second

v) System grounding

1) 11 kV and 3.3 kV	Earthed through resistance to limit the current to 300A or high resistance grounding through artificial earthing transformer and earthing resistance
2) 415V	solidly grounded
3) 220V DC	Ungrounded

vi) Paint shade shall be RAL 5012 (Blue).



- vii) Degree of protection
- | | | |
|----|--------------------------|-------|
| a. | Indoor motors | IP 54 |
| b. | Outdoor motors | IP 55 |
| c. | Cable box – indoor area | IP 54 |
| d. | Cable box – outdoor area | IP 55 |

5.7.3 Type

- i) AC Motors:
- Squirrel cage induction motor suitable for direct-on-line starting.
 - Crane duty motors shall be slip ring type induction motor
- ii) DC Motors: Shunt wound.

5.7.4 Rating

- i) Continuously rated (S1). However, crane motors shall be rated for S4 duty i.e. 40% cyclic duration factor.
- ii) Maximum continuous motor ratings shall be at least 10% above the maximum load demand of the driven equipment unless otherwise specified, under entire operating range including voltage and frequency variations.
- iii) Motors starting shall be as per IEC-60034 (part12)

5.7.5 Temperature Rise

- i) Air cooled motors 70⁰C by resistance method for both class 130(B) and 155(F) insulation.
- ii) Water cooled motors 80⁰C over inlet cooling water temperature, by resistance method for both class 130(B) and 155(F) insulation.

5.7.6 Operational Requirements

- i) Starting Time
- a) For motors with starting time upto 20 secs. at minimum permissible voltage during starting, the locked rotor withstand time under hot condition at highest voltage limit shall be at least 2.5 secs. more than starting time .
- b) For motors with starting time more than 20secs. and upto 45secs. at minimum permissible voltage during starting, the locked rotor withstand time under hot condition at highest voltage limit shall be at least 5 secs. more than starting time.



- c) For motors with starting time more than 45secs. at minimum permissible voltage during starting, the locked rotor withstand time under hot condition at highest voltage limit shall be more than starting time by at least 10% of the starting time.
- d) Speed switches mounted on the motor shaft shall be provided in cases where above requirements are not met.
- ii) Torque Requirements
 - a) Accelerating torque at any speed with the lowest permissible starting voltage shall be at least 10% motor full load torque.
 - b) Pull out torque at rated voltage shall not be less than 205% of full load torque. It shall be 275% for crane duty motors.
- iii) Starting voltage requirement
 - a) All motors (except mill motors):
 - 80% of rated voltage for motors upto 4000 kW
 - 75% of rated voltage for motors above 4000 kW
 - b) For mill motors
 - 85% of rated voltage for motors above 1000 kW
 - 90% of rated voltage for motors below 1000 kW

5.7.7 Design and constructional features

- i) Suitable single phase space heaters shall be provided on motors rated 30kW and above to maintain windings in dry condition when motor is standstill. Separate terminal box for space heaters and RTDs shall be provided.
- ii) All motors shall be either totally enclosed fan cooled (TEFC) or totally enclosed tube ventilated (TETV) or closed air circuit air cooled (CACCA) type. However, motors rated 3000 kW or above can be closed air circuit water cooled (CACW).
- iii) For hazardous location such as fuel oil facilities area, the enclosure of motors shall have flame proof construction conforming to IS:2148 as detailed below
 - 1) Fuel oil area Group – IIB
 - 2) Hydrogen generation Group – IIC (or Group-I Div-II as per NEC)
 plant area
- iv) Winding and Insulation
 - 1) Type Non-hygroscopic, oil resistant, flame resistant



- | | | |
|----|----------------------------|--|
| 2) | Starting duty | Two hot starts in succession, with motor initially at normal running temperature |
| 3) | 11kV, 3.3 kV AC motors | Class 155(F) : with winding temperature rise limited to class 130(B). They shall withstand 1.2/50microsec. Impulse Voltage wave of 4U+5 kV (U=Line voltage in kV). The coil inter-turn insulation shall be as per IEC-60034 – Part 15 followed by 1 min power frequency high voltage test of appropriate voltage on inter turn insulation. |
| 4) | 415V AC and 220V DC motors | Class 130 (B) |
- v) Motors rated above 1000KW shall have insulated bearings to prevent flow of shaft currents.
- vi) Motors with heat exchangers shall have dial type thermometer with adjustable alarm contacts to indicate inlet and outlet primary air temperature.
- vii) Noise level and vibration shall be limited within the limits prescribed in IS: 12065 and IS: 12075 respectively.
- viii) In 11kV and 3.3kV motors, at least four numbers simplex/ two numbers duplex platinum resistance type temperature detectors shall be provided for each phase of stator winding. Each bearing shall preferably be provided with dial type thermometer with adjustable alarm contact and two numbers duplex platinum resistance type temperature detector Motor body shall have two earthing points on opposite sides.
- ix) 11kV and 3.3kV motors can be offered with either elastomould termination or dust tight phase separated double walled (metallic as well as insulated barrier) cable boxes. In case elastomould terminations are offered, then protective cover and trifurcating sleeves shall also be provided. Removable gland plates of thickness 3 mm (hot/cold rolled sheet steel) or 4 mm (non magnetic material for single core cables) shall be provided in case of cable boxes.
- x) All motors shall be so designed that maximum inrush currents and locked rotor and pullout torque developed by them at extreme voltage and frequency variations do not endanger the motor and driven equipment.
- xi) The motors shall be suitable for bus transfer schemes provided on the 11kV, 3.3 kV, 415V systems without any injurious effect on its life.
- xii) Motors rated 2000kW and above shall be provided with neutral current transformers of PS class on each phase in a separate neutral terminal box for differential protection.

5.8 11kV & 3.3kV SWITCHGEARS

The following 11kV and 3.3kV switchgears shall be provided:

- a) All 11KV unit switchgears as required for unit auxiliaries
- b) All 3.3KV unit switchgears as required for unit auxiliaries
- c) 11kV station switchgears for providing 11kV supply feeders to station facilities (e.g. coal handling system, ash handling system, water systems etc.) and tie feeders with unit switchgears

5.8.1 Codes and standards

The equipment, materials and service shall conform to the latest applicable provision of the following standards :

IS : 722	AC electricity meters
IS : 996	Single phase small AC and universal electrical motors.
IS : 1248	Direct Acting indicating analogue electrical measuring instruments and Accessories
IS : 13947	Degree of protection provided by enclosures for low voltage switchgear and control gear
IS : 2544	Porcelain post insulators for systems with nominal voltages greater than 1000V
IS : 2705	Current transformers.
IS : 3156	Voltage Transformers
IS : 3231	Electrical relays for power system protection
IS : 3427	Metal enclosed switchgear and control gear
IS : 5082	Specification for wrought aluminium and aluminium alloy bars, rods, tubes and selections for electrical purposes.
IS : 6005	Code of practice for phosphating of iron and steel.
IS : 8686	Specification for static protective relays.
IS : 9046	AC contactors for voltages above 1000 volts and upto and including 11000V.
IS : 9224	Low voltage fuses
IS : 9385	HV fuses
IS : 9431	Specification for indoor post insulators of organic material for system with nominal voltages greater than 1000 volts upto and including 300 kV
IS : 9921	AC dis-connectors (isolators) and earthing switches for voltages above 1000V
IS : 11353	Guide for uniform system of marking and identification of conductors and apparatus terminals.
IS : 13118	Specification for high voltage AC circuit breakers.
IEC-60099 part 4	Metal oxide surge arrestor without gap for AC system
IEC-62271-100	High voltage alternating current circuit breakers.
IEC-60099-1	Non-linear resistor type gapped arrestor for AC systems
IEC-60298	High voltage metal enclosed switchgear and control gear.
CIGRE WG 13.02 Chapter-3	Recommendation for substitute test for switching over voltage test



5.8.2 Technical Parameters

- i) The switchgears shall be indoor, metal clad, draw out type. The feeders rated 2000kW and above shall be provided with vacuum/ SF₆ circuit breakers. Outgoing breakers shall be suitable for switching transformers and motors at any load. They shall be capable of being used for frequent direct-on-line starting of squirrel cage induction motors of following ratings

- a) 3.3KV Above 200 kW up to 1500 kW
b) 11 kV Above 1500 kW

Surge arrestor shall be provided for each motor feeder

The operating mechanism of the circuit breakers shall be of the stored energy type DC motor operated charging springs.

- ii) The circuit breaker, contactor and switchgear assemblies shall have the following technical parameters :

a) **System parameters**

1) Nominal System voltage	11 kV	3.3 kV
2) Highest System voltage	12 kV	3.6 kV
3) Rated Frequency	50 Hz	50 Hz
4) Number of phases	Three	Three
5) System neutral earthing	Earthed through resistance to limit fault current to 300A or High resistance grounding through artificial earthing transformer and earthing resistor	
6) One minute power frequency withstand voltage		
- for Type tests	28	10
- for Routine tests	28	10
7) 1.2/50 microsecond Impulse withstand voltage	75 kV (peak)	40 kV(peak)
8) Maximum system fault level including initial motor contribution	40 kA for 1 second	40 kA for 1 second
9) Dynamic withstand rating	100 kA (peak)	
10) Control supply voltage		
- Trip and closing coils	----- 220V DC -----	



- Spring charging motor	-----220V DC ----- (240V AC can be accepted for off-site areas)
- Space heaters	----- 240V AC ----
11) Ambient temperature	50 ⁰ C
b) Busbars	
1) Continuous current rating at 50 ⁰ C ambient	as per system requirements
2) Temperature rise	- 40 ⁰ C for plain joints - 55 ⁰ C for silver plated joints
c) Constructional requirements	
1) Colour finish - exterior and interior	as mentioned elsewhere
2) Cable entry	
- Power cables	Bottom
- Control cables	Bottom
3) Bus duct entry	----Top---
4) Earthing conductor	Galvanised steel strip
d) Circuit breakers	
1) Short circuit breaking current	
- AC component	40 kA
- DC component	As per IS 13118 or IEC 62271
2) Short circuit making current	100 kA (peak)
3) Operating Duty	B – 3min – MB – 3min – MB
4) Total break time	Not more than 4 cycles
5) Total make time	Not more than 5 cycles
6) Operating Mechanism	Motor wound spring charged stored energy type as per IEC 62271
e) Relays	
One minute power frequency	2.0 kV (rms) 2.0 kV (rms)
f) Meters	
1) Accuracy class for	
a) Energy accounting and audit meters	
- on each incoming feeder of 11/3.3kV buses	Not inferior to 1.0S
- on all 11kV and 3.3kV motor feeders	-----do-----
b) other meters	1.0



Note : In case, numerical relays having built-in features of energy measurement of requisite accuracy are provided in switchgear, separate energy meter is not necessary.

2) One minute power frequency 2.0 kV (rms)

g) Current Transformer

1) Class of Insulation Class E or better

2) Rated output of each Adequate for the relays and devices connected, but not less than fifteen (15) VA.

3) Accuracy class

a) Measurement core for energy accounting and audit meters

- on each incoming feeder of 11/3.3kV buses Not inferior to 1.0S

- on all 11kV and 3.3kV motor feeders -----do-----

b) Other meters

1.0

4) Protection core

- differential and core balance CTs PS

- other protection CTs 5P20

5) Minimum primary earth fault current to be detected by core balance CT

3 A

h) Voltage Transformers

1) Rated voltage factor 1.2 continuous for all VTs, and 1.9 for 30 sec. for star connected VTs

2) Measurement

- for energy accounting and audit Not inferior to 1.0S

- for others 1.0

3) Protection 3P

i) Fuses

1) Voltage class 11kV 3.3kV

2) Rupturing Capacity Adequate for 100 kA (peak)

3) Rated current As per application

j) Surge arresters

1) Nominal discharge current (8x20 micro second) 11 kV 3.3kV

500 Amp



2) Maximum system voltage	12 kV	3.6kV
3) Maximum standard impulse spark over voltage (peak)	25 kV (without any positive tolerance)	
4) Residual voltage at nominal discharge current	25 kV	8kV
5) Temporary over voltage capability (rms)		
- For 10,000 seconds	12 kV	3.6kV
- For 5 seconds	14.3 kV	4.3kV
6) Installation	Inside the switchgear panel	

k) Contactors

1) Nominal system voltage	----	3.3kV
2) Highest system voltage	----	3.6kV
3) Rated frequency	----	50kZ
4) Control supply voltage	-----	220 V DC
5) Utilization category	-----	AC-3

l) Transducers

1) Current transducers

a) Input	0-1 A (CT secondary)
b) Rated frequency	50 Hz
c) Output	4-20 mA (2 Nos. decoupled)
d) Accuracy	0.5%

2) Voltage transducers

a) Input	110V, 50 Hz (from VT secondary)
b) Output	4-20 mA (2 Nos. de-coupled)
c) Accuracy	0.5%

3) VAR transducers

a) Input	3 phase, 3-wire 1 A (CT secondary) 110 V (VT secondary)
b) Rated frequency	50 Hz
c) Output	4-20 mA (2 nos. de-coupled)
d) Accuracy	0.5%

4) Watt transducers

a) Input	3 phase, 3-wire 1A (CT secondary) 110V (VT secondary)
b) Rated frequency	50 Hz
c) Output	4-20 mA (2 nos. decoupled)
d) Accuracy	0.5%

5) Frequency transducers

a) Input	110V (VT secondary)
b) Rated frequency	50 Hz
c) Range	45 to 55 Hz
d) Output	4-20 mA (2 nos. decoupled)
e) Accuracy	0.5%

5.8.3 Bus Transfer Scheme

- i) The 11kV buses of unit switchgears shall be connected to their respective unit auxiliary transformer through segregated bus-ducts. These buses of unit switchgears shall also be connected to 11kV buses of station switchgears through tie feeders and breakers located at the unit and station end. Automatic fast bus transfer scheme shall be provided between 11kV unit and station switchgears such that in case of loss of supplies to unit switchgears from UAT, the same shall be restored from respective station switchgears. The automatic bus transfer system shall consist of fast, slow etc. transfer in auto mode. The bus transfer scheme shall also have manual mode to initiate transfer command manually.
- ii) Manual live change-over and Automatic Reserve Closure (ARC)/ slow change-over shall be provided for 11kV station to station switchgear and for main and reserve incomers to 3.3kV unit switchgears.

5.8.4 Metering

The energy meters shall be provided as per the Central Electricity Authority (Installation and Operation of Meters) Regulations, 2006 and its amendments. However, the following energy accounting and audit meters shall be provided in general :

- On each incoming feeder of 11kV and 3.3kV buses.
- On all 11kV and 3.3kV motor feeders

Energy accounting and audit meters shall be of accuracy class of 0.2S. The accuracy class of CTs and VTs shall not be inferior to that of associated meters. In case, numerical relays having built-in features of energy measurement of requisite accuracy are provided in switchgear, separate energy meter is not necessary.

5.8.5 General Technical Requirements**a) Switchgear panel**

- i) The switchgear shall have a single front, single tier, fully compartmentalized, metal clad construction complying with clause No. 3.102.1 of IEC-60298, comprising of a row of free standing floor mounted panels. Each circuit shall have a separate vertical panel with distinct compartments for circuit breaker/contactors, cable termination, main busbars and auxiliary control devices. The adjacent

panels shall be completely separated by steel sheets except in busbar compartments where insulated barriers shall be provided to segregate adjacent panels.

- ii) The circuit breakers/ contactors and bus VTs shall be mounted on withdrawable trucks which shall roll out horizontally from service position to isolated position.
- iii) The trucks shall have distinct Service, Test and Isolated positions. It shall be possible to close the breaker/contactors compartment door in Isolated position also, so that the switchgear retains its specified degree of protection. While switchboard designs with doors for breaker/contactors compartments would be preferred, standard designs of reputed switchgear manufacturer's where the truck front serves as the compartment cover may also be considered, provided the breaker/contactors compartment is completely sealed from all other compartments and retains the IP-4X degree of protection in the Isolated position.
- iv) The switchgear assembly shall be dust, moisture, rodent and vermin proof with the truck in any position Service, Test and Isolated or removed, and all doors and covers closed. All doors, removable covers and glass windows shall have gaskets all round with synthetic rubber or neoprene gaskets.
- v) The VT/ relay compartments shall have degree of protection not less than IP:52 in accordance with IS:13947. However, remaining compartments can have a degree of protection of IP: 4X. No louvers/opening shall be provided on the top of the panel. All other louvers if provided, shall have very fine brass or GI mesh screen. Tight fitting gaskets are to be provided at all openings in relay compartment.
- vi) Enclosure shall be constructed with rolled steel sections and cold rolled steel sheets of at least 2.0 mm thickness, Gland plates shall be 2.5 mm thick made out of hot rolled or cold rolled steel sheets and for non magnetic material it shall be 3.0 mm.
- vii) The switchgear shall be cooled by natural air flow and forced cooling shall not be accepted.
- viii) Total height of the switchgear panels shall not exceed 2600 mm. The height of switches, push buttons and other hand operated devices shall not exceed 1800 mm and shall not be less than 700 mm.
- ix) Safety shutters complying with IEC-60298 shall be provided to cover up the fixed high voltage contacts on busbar and cable sides when the truck is moved to TEST and ISOLATED position. The shutters shall move automatically, through a linkage with the movement of the truck.
- x) The switchgears shall have the facility of extension on both sides.



b) Circuit breaker

- i) The circuit breakers shall be of Vacuum/ Sulphur hexa flouride (SF₆) type. They shall comprise of three separate, identical single pole interrupting units, operated through a common shaft by a sturdy operating mechanism. Surge arrestor shall be provided for each motor/ transformer feeder.
- ii) Circuit breaker shall be restrike free, stored energy operated and trip free type. Motor wound closing spring charging shall only be acceptable. An anti-pumping relay shall be provided for each breaker, even if it has built-in mechanical anti-pumping features.
- iii) Plug and socket isolating Contacts for main power circuit shall be silver plated, of self aligning type, of robust design and capable of withstanding the specified short circuit currents. They shall preferably be shrouded with an insulating material. Plug and socket contacts for auxiliary circuits shall also be silver plated, sturdy and of self aligning type having a high degree of reliability. Thickness of silver plating shall not be less than 10 microns.
- iv) In case of SF₆ gas type circuit breaker, necessary pressure/ density monitoring switch along with the contact for remote indication shall be provided.
- v) Supervision relays provided for trip coil monitoring.
- vi) Castle key interlocks shall be provided to prevent opening of cable compartment door when breaker is closed and bus bar compartment when any of the incomers to bus are closed.
- vii) Testing of circuit breaker shall be possible in isolated position by keeping the control plug connected.
- viii) In a switchgear if there are more than one possible feed (including bus coupler) then lockout relay (86) contact of incoming breakers shall be connected in series in closing circuit of each of incoming breakers.
- ix) Automatic change-over shall be provided for bus sections with suitable synchronizing check facility. The change-over shall be blocked in case of fault on the bus section. Dead Bus change-over after voltage collapse shall also be provided as back-up.
- x) Core balance CTs shall be provided for outgoing motor and transformer feeders having CT ratios greater than 50/1A.



c) Protections

- i) Incomer, bus-coupler and outgoing feeders except motor and transformer feeders :
 - a) Time graded over-current protection
 - b) Under voltage protection for bus to trip motors under sustained under voltage conditions
 - c) Earth fault relays shall be provided for selective tripping of feeders
- ii) Outgoing 11kV/3.3kV, 11kV/433V auxiliary service transformers feeders :
 - a) Inverse/ Definite time over-current protection (with instantaneous element)
 - b) Buchholz protection (for oil filled transformers)
 - c) Zero sequence/ earth fault current protection for transformer feeder protection
 - d) Winding temperature high (alarm and trip)
 - e) Oil temperature high (alarm and trip) (for oil filled transformers)
 - f) Zero sequence protection on LV side (neutral CT to be provided in case of solid grounding)
- iii) Outgoing 11kV, 3.3kV motor feeders :
 - a) Instantaneous short- circuit protection
 - b) Over-load protection with unbalance current feature
 - c) Differential protection (for motors above 2000KW)
 - d) Locked rotor protection, if not covered by the overload protection
 - e) Zero sequence current protection
 - f) Winding/ bearing temperature protection by means of RTDs connecting the same to DDCMIS.

d) General requirements of Numerical Relays

- i) All numerical relays, auxiliary relays and devices shall be of types, proven for the application; satisfying requirements specified elsewhere and shall be subject to Purchaser's approval. Numerical Relays shall have appropriate setting ranges, accuracy, resetting ratio, transient overreach and other characteristics to provide required sensitivity to the satisfaction of the Owner. All the numerical relays shall have communications on two ports, local front port communication to laptop and a second port on IEC 61850 port to communicate with the data concentrator through LAN and Ethernet switches.
- ii) The Numerical relays shall have communication, Metering and monitoring facility. The Numerical relays shall be networked through Data Concentrators of the main plant to HMI and further integrated to DDCMIS system. All the feeders shall be remote controlled from DDCMIS/PLC and from the switchgear.
- iii) All relays and timers shall be rated for control supply voltage as mentioned elsewhere under parameters and shall be capable of satisfactory continuous operation between 80-120% of the rated voltage. Making, carrying and breaking current ratings of their contacts shall be adequate for the circuits in which they are used. Interrogation voltage for the binary inputs shall be suitably selected to ensure avoidance of mal operation due to stray voltages.
- iv) The protective relays shall have at least 10 no. potential free contacts (Programmable) Auxiliary relays shall have contacts as required. Relay output contacts shall be suitable for directly wiring in the breaker closing and trip circuit operating from 220 V DC control voltage.
- v) Failure of a control or auxiliary supply and de-energisation of a relay shall not initiate any circuit breaker /contactor operation. All relays shall withstand a minimum test voltage of 2 KV AC Rms for one minute.
- vi) All the numerical relays shall have communications on two ports; local front port communication to laptop and a second port on IEC 61850 port to communicate with the data concentrator through LAN.
- vii) Relays shall be suitable for electrical measurement including voltage, current, power (active/reactive) and energy parameters.
- viii) Mapping details of all the details shall be submitted in IEC format.
- ix) Relays shall have separate output for individual functionality and the master trip shall be software configurable in case of multi output relays. Relays shall have event recording feature, recording of abnormalities and operating parameters with time stamping.



- x) Preferably comprehensive single numerical relay shall have provision of both current and voltage inputs. The current operated relay shall have provision for 4 sets of CT inputs, 3 nos. for phase fault and 1 CT input for earth fault. Relay shall be suitable for both residually connected CT input as well as CBCT input. The voltage-operated relay shall have provision for 3 PT inputs. Relays shall be suitable for CT secondary current of 1A/5A selectable at site. Relays used in incomers and bus couplers shall have provision of two sets of voltage signal inputs for the purpose of synchronization.
- xi) All CT and PT terminals shall be provided as fixed type terminals on the relay to avoid any hazard due to loose connection leading to CT opening or any other loose connection. In no circumstances Plug In type connectors shall be used for CT/ PT connections. Vendor to ensure the same for all protective relay models offered.
- xii) All numerical relay shall have key pad / keys to allow relay settings from relay front. All hand reset relays shall have reset button on the relay front. Relay to be self or hand reset shall be software selectable. Manual resetting shall be possible from remote.
- xiii) Relays shall have suitable output contact for breaker failure protection.
- xiv) Relays shall have self diagnostic feature with self check for power failure, programmable routines, memory and main CPU failures.
- xv) Relays shall have at least two sets or groups of two different sets of adaptable settings. Relays shall have multiple IEC/ ANSI programmable characteristics.
- xvi) Design of the relay must be immune to any kind of electromagnetic interference. Vendor to submit all related type test reports for the offered model along with the offer.
- xvii) For breaker control from DDCMIS/PLC, hardwired potential free contacts shall be provided from DDCMIS/PLC, to the numerical relays. No separate coupling relays shall be provided.
- xviii) Trip circuit supervision shall be provided for all feeders to monitor the circuit breaker/ contactor trip circuit both in pre trip and post trip conditions.
- xix) Schematics requiring auxiliary relays /timers for protection function shall be a part of numerical relay. The number of auxiliary relay and timer function for protection function shall be as required. Auxiliary relays for interlocking purpose shall be of self reset type.



- xx) Bus no volt condition shall be configured to a output contact of the relay of all incomers
- xxi) Timer functions shall be programmable for on/off delays.
- xxii) The numerical relay shall be able to provide supervisory functions such as trip circuit monitoring, circuit breaker state monitoring, PT and CT supervisions and recording facilities with Post fault analysis.
- xxiii) The numerical processor shall be capable of measuring and storing values of a wide range of quantities, all events, faults and disturbance recordings with a time stamping using the internal real time clock. Battery back up for real time clock in the event of power supply failure shall be provided.
- xxiv) 150 time tagged events/ records should be able to store with time stamping Last 5 faults storage including the indication, protection operated , fault location relay and operating time, currents, voltage and time.
- xxv) Diagnostics Automatic testing, power on diagnostics with continuous monitoring to ensure high degree of reliability shall be shall be provided. The results of the self reset functions shall be stored in battery back memory. Test features such as examination of input quantities, status of digital inputs and relay outputs shall be shall be available on the user interface
- xxvi) The alarm/status of each individual protection function and trip operation shall be communicated to DDCMIS/PLC The numerical relay system shall have built-in features/hardware interface to provide such inputs to DDCMIS/PLC for analog/digital values The provision of receiving the DC incoming supplies and its monitoring shall preferably be made in one bus PT. Panel.
- xxvii) Sequence of events shall have 1 ms resolution at device level.
- xxviii) Measurement accuracy shall be 1 % for RMS Current and voltage.
- xxix) It shall be possible to carryout open / close operation of breakers from a laptop by interfacing from the relay front port (RS232) during initial commissioning.
- xxx) Ethernet switches shall be 'substation hardened' and shall comply to IEC61850-3 for communications and environment requirements. The Ethernet switches shall be of managed type with two(2) no. of Fibre optic cable ports and Fourteen/Six of Copper ports to achieve the LAN configuration. These switches shall be mounted inside the switchgear Panel.



- xxxix) Relay shall be suitable to accept both AC & DC supplies with 110V AC or 220V DC with tolerance of 80% to 120 % of rated voltage
- xxxii) Relay shall be immune to capacitance effect due to long length of connected control cables. Any external hardware, if required for avoiding mal operation of the relay due to cable capacitance shall be included as a standard feature. All IOs shall have optical isolation. Analog inputs shall be protected against switching surges, harmonics etc.
- xxxiii) No separate earth bus shall be required for the relays. It shall be possible to connect the relay earth to the common earth bus in the switchgear panel which shall be connected to the plant earth mat.
- xxxiv) Numerical relays shall have two level pass word protections, one for read only and other for authorization for modifying the setting etc.

e) Contactor

- i) Mechanically latched type contactors shall be backed by HRC fuses for outgoing motor feeders. The high voltage contactors shall be of AC-3 utilization category and shall be SF₆ or vacuum type. The fuse and contactor assembly shall be mounted on a withdrawable truck. Circuits shall be provided with suitable single phasing protection.
- ii) Surge suppressors shall be provided on all contactor controlled motor feeders.
- iii) The contactors shall close satisfactorily with a control voltage between 85 to 110 per cent and trip satisfactorily with a control voltage between 70 to 100 percent of the rated control supply voltage. Mechanical indication of contactor open / closed shall be provided. An anti-pumping relay shall be provided even if it has mechanical anti-pumping feature. Trip circuit supervision relay shall be provided to monitor the healthiness of trip coil.

f) Surge arrester

The surge arrestors shall be provided for all motor/ transformer feeders and shall be metal oxide, gapped or gap less type generally in accordance with IEC 60099-1 and suitable for indoor duty. These shall be mounted within the switchgear cubicle between line and earth, preferably in the cable compartment. Surge arrester selected shall be suitable for non-effectively earthed system and rating shall be in such a way that the value of steep fronted switching over voltage generated at the switchgear terminals shall be limited to the requirements of switchgear.



g) Control and Interlocks

- i) The circuit breaker/ contactor will normally be controlled from remote control panels through closing and shunt trip coils. The control switch located on the switchgear would normally be used only for testing of circuit breaker/ contactor in isolated position, and for tripping it in an emergency.
- ii) The circuit-breaker shall have three distinct positions as follows:

'Service'	Both power and control contacts connected.
'Test'	Power contacts isolated, control contacts connected.
'Isolated'	Both power and control contacts isolated.
- iii) 'Red', 'Green' and 'white' indication lamps shall be provided on the panel to indicate breaker 'Close', 'Open' and 'Auto-Trip' position. In addition to above, mechanical indicator shall be provided which shall be clearly visible to the operator standing in front of the panel.
- iv) Suitable indication to show the circuit-breaker 'Service' and 'Test' positions shall be provided.
- v) Facilities shall be provided for mechanical tripping of the breaker/ contactor and for manual charging of the stored energy mechanism for a complete duty cycle, in an emergency. These facilities shall be accessible only after opening the compartment door.
- vi) Six (6) normally open (NO) and six (6) normally closed (NC) auxiliary contacts shall be provided in Incomer, Bus coupler and tie feeders for future use. For all other breakers/ contactor modules four (4) NO and four (4) NC contacts shall be provided. The above contacts shall be wired out to the terminal blocks. Contact multiplication, if necessary to meet the above contact requirement, shall be done through electrical reset latch relay.

h) Busbars and Insulators

- i) All busbar and jumper connections shall be of high conductivity aluminium alloy. They shall be adequately supported on insulators to withstand electrical and mechanical stresses due to specified short circuit currents.

Busbar cross-section shall be uniform throughout the length of switchgear. Busbars and other high voltage connection shall be sufficiently corona free at maximum working voltage. All busbars shall be colour coded.
- ii) The temperature rise of the horizontal and vertical busbars when carrying the rated current shall be in no case exceed 55⁰C for silver plated joints

and 40⁰C for all other type of joints. The temperature rise at the switchgear terminals intended for external cable termination shall not exceed 40⁰C. Further the switchgear parts handled by the operator shall not exceed a rise of 5⁰C.

i) Earthing and Earthing Devices

- i) A galvanised steel or copper earthing bus shall be provided at the bottom and shall extend through out the length of each switchgear. It shall be bolted/ welded to the framework of each panel and each breaker/ contactor earthing contact bar.
- ii) The earth bus shall have sufficient cross section to carry the momentary short circuit and short time fault currents to earth as indicated under switchgear parameters without exceeding the allowable temperature rise.
- iii) All joint splices to the earth bus shall be made through atleast two bolts and taps by proper lug and bolt connection.
- iv) The truck and breaker/ contactor frame shall get earthed while the truck is being inserted in the panel and positive earthing of the truck and breaker/ contactor frame shall be maintained in all positions i.e. Service, Test and Isolated as well as throughout the intermediate travel. The truck shall also get and remain earthed when the control plug is connected irrespective of its position.
- v) All metallic cases of relays, instruments and other panel mounted equipment shall be connected to earth by independent stranded copper wires of suitable size.
- vi) VT and CT secondary neutral point earthing shall be at one place only on the terminal block. Such earthing shall be made through links so that earthing of one secondary circuit may be removed without disturbing the earthing of other circuits.
- vii) Separate earthing trucks shall be provided for maintenance work. These trucks shall be suitable for earthing the switchgear busbars as well as outgoing/ incoming cables or bus ducts. The trucks shall have a voltage transformer and an interlock to prevent earthing of any live connection. The earthing trucks shall in addition have a visual and audible annunciation to warn the operator against earthing of live connections.

As an alternative to separate earthing trucks, built-in earthing facilities for the busbars and outgoing/ incoming connections, in case such facilities are available in their standard proven switchgear design shall also be acceptable. The inbuilt earthing switches shall have provision for short circuiting and earthing a circuit intended to be earthed. These switches shall be quick make type, independent of the action of the operator and shall be operable from the front of the switchgear panel.



These switches shall have facility for padlocking in the earthed condition.

- viii) Interlocks shall be provided to prevent :
- Closing of the earthing switch if the associated circuit breaker truck is in Service position.
 - Insertion of the breaker truck to Service position if earthing switch is in closed position.
 - Closing of the earth switch on a live connection. Three (3) nos. voltage capacitive dividers shall be provided on each phase of the section intended for earthing and three (3) nos. "RED" neon lamps/ LEDs connected to these on the panel front for visual indication.
 - Energising an earthed Section : Complete details of arrangement offered shall be included in the bid, describing the safety features and interlocks.
- ix) The earthing device (truck/ switch) shall have the short circuit withstand capability equal to that of associated switchgear panel. 4 NO + 4 NC of auxiliary contacts of the earthing device shall be provided for interlocking purpose.
- x) All hinged doors shall be earthed through flexible earthing braid.

j) Painting

All sheet steel work shall be pretreated, in tanks, in accordance with IS:6005. Degreasing shall be done by alkaline cleaning. Rust and scales shall be removed by pickling with acid. After pickling, the parts shall be washed in running water. Then these shall be rinsed in slightly alkaline hot water and dried. The phosphate coating shall be "Class-C " as specified in IS : 6005. The phosphated surfaces shall be rinsed and passivated prior to application of stoved lead oxide primer coating. After primer application, Electrostatic Powder Painting shall be used. Finishing paint shade for complete panels excluding end covers shall be RAL9002 and RAL5012 for extreme end covers of all switchgears.

k) Instrument transformers (CT's and VT's)

- i) All current and voltage transformers shall be completely encapsulated cast resin insulated type, suitable for continuous operation at the ambient temperature prevailing inside the switchgear enclosure. The class of insulation shall be E or better.
- ii) Current transformers may be multi or single core and shall be located in the cable termination compartment. All voltage transformers shall be

single phase type. The bus VTs shall be housed in a separate panel on a truck so as to be fully withdrawable. Separate set of current transformer shall be provided for differential protection of the feeder.

- iii) Core balance CTs (CBCT) shall be provided on outgoing motor and transformer feeders having CT ratio 50/1A or more. These CBCTs shall be mounted inside the switchgear panel.
- iv) All voltage transformers shall have suitable HRC current limiting fuses on both primary and secondary sides. Primary fuses shall be mounted on the withdrawable portion. Replacement of the primary fuses shall be possible with VT truck in Isolated test position.

I) Instruments and Meters

- i) Indicating instruments and integrating meters shall be flush mounted on panel front. The instruments shall be of atleast 96 mm square size with 90° scales. The covers and cases of instruments and meters shall provide a dust and vermin proof construction.
- ii) Ammeters on motor feeders shall have a compressed scale at the upper current region to cover the motor starting current without graduation from one to six times the rated CT secondary current. These shall be suitable to withstand the above current of motors which can last upto 30 seconds (under stalled condition) without any damage or loss of accuracy.
- iii) Watt-hour meters shall preferably be 3-phase two (2) element type suitable for measurement of unbalanced loads in three phase three wire system.
- iv) Watt-hour meters shall preferably be provided in drawout cases with built-in testing facilities. Alternatively, they may have test blocks to facilitate testing of meters without disturbing CT and VT secondary connections. Watthour meters shall have reverse running stops. They shall have six digit register indicating primary circuit energy in MWH with atleast count on 0.1 MWH.
- v) Suitable self powered transducers as per IS : 12784 Part - I for feeding signals to panel mounted electrical meters (ammeters, voltmeters, VAR meters and wattmeters etc.) and DCCMIS shall be provided.

Transducers shall be tested as per IEC – 600298 or impulse test etc and short circuit withstand capability as per ANSI C 37.90a, 1989.

Transducers shall be provided with two decoupled 4-20mA output signals, one for meter and one for DDCMIS. Current limiting features shall be provided for all the transducers.



- vi) Necessary hardware shall be provided in the switchgear panel like coupling relays (24VDC with maximum burden of 2.5VA), auxiliary relays in addition to current/ bus-voltage transducers (4-20 mA, dual output) etc. to effect interlocks, exchange information/ status and exercise control from remote.

m) Control and Selector switches

- i) Control and selector switches shall be of heavy duty, rotary type with escutcheon plates clearly marked to show the positions. The switches shall be of sturdy construction suitable for mounting on panel front. Switches with shrouding of live parts and sealing of contacts against dust ingress shall be preferred.
- ii) On-Off control switches shall have three positions and shall be spring return to 'Neutral' from close and trip positions. They shall have two contacts closing in close position and two contacts closing in trip positions, and shall have Pistol Grip handles. Lost motion feature shall be provided wherever required.
- iii) Selector switch shall have two stay put positions as per the module requirements indicated elsewhere. They shall have two contacts for each of the positions and shall have black Spade handle.
- iv) Ammeter and Voltmeter selector switches shall have four stay-put positions with adequate number of contacts for three phase system. These shall have oval handles. Ammeter selector switches shall have make before break type contacts to prevent open circuiting of CT secondary.

n) Indicating lamps

- i) Indicating lamps shall be of the panel mounting, LED type and low watt consumption preferably built in the lamp assembly. The lamps shall have escutcheon plates marked with its function, wherever necessary.
- ii) Lamps shall have translucent lamp-covers of the following colours, as warranted by the application :

Red	Closed
Green	Open
White	Auto-trip
Blue	For all healthy conditions (e.g. control supply, spring charged, and lock out relay coil healthy)
Amber	For all alarm conditions (e.g. pressure low, over load) also for Service and Test positions indications.



o) Control supply and Space heater supply

- i) Each switchboard shall be provided with two (2) No. of 220V DC feeders for the control supply.
- ii) Under voltage relay to monitor each of the control supply shall be provided.
- iii) All DC circuits shall be fused on both poles. Single phase AC circuits shall have fuses on line and link on neutral.

p) Space heater

- i) Each switchgear panel shall be equipped with thermostatically controlled space heater(s), suitably located in breaker/contactors and cable compartments to prevent condensation within the enclosure. The space heater shall be connected to 240 V single phase AC auxiliary supply available in the switchgear, through switches and fuses provided separately for each panel.
- ii) For motor space heater supply, one breaker/ contactor normally closed (NC) auxiliary contact of each motor feeder shall be wired out in series of switch fuse upto terminals block in the respective panels of switch boards. The motor space heater supply shall be taken from Panel space heater supply given to switch board.
- iii) A 240V single phase 50 Hz AC plug point shall be provided in the interior of each cubicle with ON-OFF switch for connection of hand lamp.

q) Terminal blocks

- i) Terminal blocks shall be 650 Volts grade, 10 Amps rated, one piece moulded complete with insulating barriers. clip on type terminals, washers, nuts and identification strips.
- ii) Terminal blocks for CT and VT secondary leads shall be provided with links to facilitate testing, isolation star/ delta formation and earthing. Terminal blocks for CT secondary shall have the short circuiting facility.
- iii) Atleast 10% spare terminals for external connections shall be provided on each panel and these spare terminals shall be uniformly distributed on all terminal blocks. Space for adding another 10% spare terminals shall also be available in each panel.

r) Power cable termination

- i) Cable termination compartment shall receive stranded Aluminium conductor, XLPE insulated, shielded, armoured/ unarmoured, PVC jacketed, single core/ three core unearthed/ earthed grade power cable(s).



- ii) A minimum clearance of about 600 mm shall be kept between the cable lug bottom ends and gland plates for stress cone formation for XLPE cables. Interphase clearance in the cable termination compartment shall be adequate to meet electrical and mechanical requirement besides facilitating easy connections and disconnections of cables.
 - iii) Cable termination compartment shall be complete with power terminals, power lugs and associated hardware and removable undrilled gland plates. For all single core cables gland plates shall be of nonmagnetic material.
- s) **Name plates and Labels**
- i) Each switchgear shall have a name plate for its identification. All enclosure mounted equipment shall be provided with individual engraved name plates for clear equipment identification. All panels shall be identified on front as well as backside by large engraved name plates giving the distinct feeder description along with panel numbers. Back side name plates shall be fixed in panel frame and not on the rear removable cover.
 - ii) Name plate shall be of non-rusting metal or 3-ply lamicaid with white engraved letterings, on black background. Inscriptions and lettering shall be subjected to Purchaser's approval.

5.8.6 Spare feeders

10% spare feeders with at least one of each type of highest rating shall be provided in each switchgear.



5.9 415V SWITCHGEARS AND NON-SEGREGATED PHASE BUS DUCT, DC BOARDS

All 415V switchgears (i.e Power control centres (PCCs), Motor control centres (MCCs)), 415V non-segregated phase bus duct, Emergency Power and Motor Control Centres (EPMCC) and DC Boards for unit auxiliaries shall be provided.

5.9.1 Codes and Standards

The equipment, materials and service shall conform to the following standards :-

IS : 5	Colours for ready-mixed paints and enamels.
IS: 694	PVC insulated cables for working voltages upto and including 1100V
IS : 722	AC Electricity Meters
IS : 1248	Electrical Indicating instruments
IS : 13947 Part 1	Degree of protection provided by enclosures for low voltage Switchgear and Control gear
IS : 13947Part-2 / IEC-60947	AC Circuit Breakers
IS : 2551	Danger Notice Plates
IS : 2629	Hot dip galvanising
IS : 2705	Current Transformers
IS : 13947Pt 4,Sec-1 (IEC-60947)	Contactors and motors starter for voltages not exceeding 1000 V AC or 1200 V DC
IS : 3043	Code of practice for earthing
IS : 3072	Code of practice for installation and maintenance of Switchgear
IS : 3156	Voltage Transformers
IS : 3202	Code of practice for climate proofing of electrical equipment
IS : 3231	Electrical relays for power system protection
IS : 13947	Air-Break Switches, air break disconnectors, air Break disconnector and fuse combination units for voltages not exceeding 1000V AC or 1200 V DC.
IS : 13947 Pt. - I IEC -60947	General Requirements for Switchgear and Control gear for voltages <1000 V
IS : 5082	Wrought Aluminium and Aluminium alloys for electrical purposes.
IS : 6005	Code of practice of phosphating of iron and steel
IS:13947 Pt.-5 Sec.1, IEC-60947	LV switchgear and Control gear Control current devices and switching element
IS : 8623(3 parts) / IEC-60439	Specification for factory built assemblies of Switchgear and Control gear for voltages upto and including 1000V AC and 1200V DC
IS : 8686	Static Relays
IS : 13703/ IEC-60269	HRC Cartridge fuses
IS : 10118 (4 parts)	Code of practice for selection, installation and maintenance of switchgear and control gear
IS : 11171	Specification for dry type transformers



IS : 11353	Guide for uniform system of marking and identification of conductors and apparatus terminals
IS : 12021	Specification of control transformers for switchgear and Control gear for voltage not exceeding 1000V AC
IS:8084 Updated upto:1992 ANSI C37:20	Interconnecting bus bars for AC voltage above 1KV upto and including 36KV. Switchgear Assemblies including Metal enclosed Bus.

5.9.2 Technical parameters

i) The switchgears shall be indoor, metal clad having following features :

Circuit Breakers	air break, three pole, spring charged, horizontal drawout type, suitable for electrical operation
Switchgear	Fully drawout type, single front
MCC/ VDDC	Fully drawout type, single front
ACDB/ DCDB	Fixed type, single front

ii) System parameters

1) Nominal system voltage	415VAC	220V DC
2) Highest system voltage	433V	240V DC
3) Voltage variation	(±) 10%	190 – 240V DC
4) Rated frequency	50 Hz	--
5) Frequency variation	(+) 3 to (-) 5%	--
6) System earthing	solidly grounded	Unearthed
7) Maximum system fault level	50kA for 3 seconds	25kA for 1 second

5.9.3 Automatic Reserve Closure (ARC) - ARC to the reserve supply source shall be provided for 415V unit essential service and other critical switchgears.

5.9.4 Emergency PMCC (EPMCC)

One no. Emergency PMCC to cater power supply to important emergency load/ motors for safe shut-down of unit including 220V battery chargers shall be provided for each unit. It will have four (4) incoming supply feeders to it with circuit breakers at sending and receiving end of these supply feeders. The main incoming supply shall be from respective 415V PCC of the unit. The reserve supply with ARC shall be from respective 415V station PCC and other two reserve supplies shall be from diesel generating sets (one from dedicated DG set of the unit and other from common stand-by DG set). In case of failure of main incoming supply to the EPMCC, the reserve incoming supply shall be switched ON automatically and in case of total failure of AC supply of the power station, the supply from dedicated DG set shall be switched ON automatically. In case of failure of dedicated DG set, the stand-by DG set shall be switched ON.

5.9.5 Metering

The energy meters shall be provided on LV side of each incoming transformer feeder of 415V buses as per the Central Electricity Authority (Installation and Operation of Meters) Regulations, 2006 and its amendments.

Energy accounting and audit meters shall be of accuracy class not inferior to 1.0S as per CEA regulations. The accuracy class of CTs and VTs shall not be inferior to that of associated meters. In case, numerical relays having built-in features of energy measurement of requisite accuracy are provided in switchgear, separate energy meter is not necessary.

5.9.6 General technical particulars

- a) **Temperature rise** - The temperature rise of the horizontal and vertical bus bars and main bus link including all power draw out contacts when carrying 90% of the rated current along the full run shall in no case exceed 55⁰C with silver plated joints and 400C with all other types of joints over an ambient of 50⁰C.
- b) **Breakers**
 - i) Breakers shall have anti-pumping feature.
 - ii) The incomer and bus coupler breakers for switchgear shall be electrically operated with over current releases or relays.
 - iii) Breakers shall have inherent fault making and breaking capacities. They shall have shunt trip coils. In case releases are offered, the same shall have contact for energisation of lockout relay. All breakers shall have built in interlocks for equipment and personnel safety.
 - iv) Paralleling of two supplies shall be avoided by interlocking except for switchgear where auto-changerover is provided. Breaker contact multiplication, if required, shall be through latch relay.
 - v) Mechanical tripping shall be through red 'Trip' push button outside the panels for breakers, and through control switches for other circuits.
 - vi) Provision of mechanical closing of breaker only in 'Test' and 'Withdrawn' position shall be made. Alternatively, mechanical closing facility should be normally inaccessible, accessibility rendered only after deliberate removal of shrouds. It shall be possible to close the door with breaker in test position.
 - vii) Clear status indication for each circuit shall be provided through lamps, switch positions or other mechanical means.
 - viii) Supervision relay shall be provided for trip coil monitoring.



c) Switches, Contactors and Fuses

- i) Incomers for MCCs and DBs rated upto 630A could be load break isolators.
- ii) Motor starter contactors shall be of air break, electromagnetic type suitable for DOL starting of motor, and shall be of utilisation category AC-3 for ordinary and AC-4 for reversing starters. DC contactor shall be of DC-3 utilisation category.
- iii) Fuses shall be HRC type with operation indicator. Isolating switches shall be of AC 23A category when used in motor circuit, and AC 22A category for other applications. Fuse switch combination shall be provided wherever possible.
- iv) Isolating switches and MCCBs shall have door interlocks and padlocking facility.

d) Panels

- i) All switchgears, MCCs, DBs, panels, modules, local starters and push buttons shall have prominent engraved identification plates.
- ii) Local push button stations shall have metal enclosure of die cast aluminium or rolled sheet steel of 1.6mm thickness and shall be of DOP IP55. Push buttons shall be of latch type with mushroom knobs.
- iii) Where breaker/starter module front serves as compartment cover, suitable blanking covers, one for each size of modules per switchboard shall be supplied for use when carriage is withdrawn.
- iv) All non-current carrying metal work of boards/panels shall be effectively bonded to earth bus of galvanised steel, extending throughout the switchboard/ MCC/ DB. Positive earthing shall be maintained for all positions of chassis and breaker frame.
- v) Suitable trolley arrangement shall be provided for breaker/starter modules. Two trolleys per switchgear room shall be provided so that top most breaker module of all types, sizes and rating can be withdrawn on trolley and lowered for maintenance purpose.
- vi) The incoming connection to transformer of more than 1000kVA and inter-connecting sections between switchboards shall preferably be of bus ducts. The bus duct enclosure shall be made of minimum 3mm thick aluminium alloy. The section of the bus duct should have adequate strength to withstand internal and external forces resulting from the various operating conditions. Aluminium sheet hood shall be provided for outdoor bus duct enclosure joints to provide additional protection against water ingress. The bus duct top shall be sloped to prevent retention of water. The bus duct shall have DOP of IP55.



- vii) It should be possible to carryout maintenance on a feeder with adjacent feeders alive.

e) Relays and Meters

- i) All numerical relays, auxiliary relays and devices shall be of types, proven for the application; satisfying requirements specified elsewhere and shall be subject to Purchaser's approval. Numerical Relays shall have appropriate setting ranges, accuracy, resetting ratio, transient overreach and other characteristics to provide required sensitivity to the satisfaction of the Owner. All the numerical relays shall have communications on two ports, local front port communication to laptop and a second port on IEC 61850 port to communicate with the data concentrator through LAN and Ethernet switches.
- ii) The Numerical relays shall have communication, Metering and monitoring facility. The Numerical relays shall be networked through Data Concentrators of the main plant to HMI and further integrated to DDCMIS/ DDCMIS system. All the feeders shall be remote controlled from DDCMIS/ PLC and from the switchgear.
- iii) All relays and timers shall be rated for control supply voltage as mentioned elsewhere under parameters and shall be capable of satisfactory continuous operation between 80-120% of the rated voltage. Making, carrying and breaking current ratings of their contacts shall be adequate for the circuits in which they are used. Interrogation voltage for the binary inputs shall be suitably selected to ensure avoidance of mal operation due to stray voltages.
- iv) The protective relays shall have at least 10 no. potential free contacts (Programmable) Auxiliary relays shall have contacts as required. Relay output contacts shall be suitable for directly wiring in the breaker closing and trip circuit operating from 220V DC control voltage.
- v) Relays shall be suitable for efficient and reliable operation of the protection scheme. Necessary auxiliary relays, timers, trip relays, etc. required for complete scheme, interlocking, alarm, logging, etc. shall be provided. No control relay, which shall trip the circuit breaker when relay is de-energized, shall be employed in the circuits.
- vi) Relays shall be flush mounted on the front with connections at the rear shall be draw-out or plug-in type/ modular case with proper testing facilities. Provision shall be made for easy isolation of trip circuits for testing and maintenance.
- vii) Relays shall be provided with self reset contacts except the trip, lockout relays and interlocking (contact multiplication) relays which shall be manual reset type



- viii) Auxiliary relays shall be provided in the trip circuits of protections located outside the board, such as buchholz relay, temperature indicators, fire protection, etc.
- ix) Suitable measures shall be provided to ensure that transients present in CT and VT connections due to extraneous sources in 400kV system do not cause damage to static circuit.
- x) Only DC/ DC converters shall be provided in the solid state devices/ relays wherever necessary to provide a stable auxiliary supply for relay operation
- xi) Control circuits shall operate at suitable voltage of 110V AC or 220V DC. Necessary control supply transformers having primary and secondary fuses shall be provided for each MCC, 2 x 100% per section. However the breakers shall operate on 220V DC. The auxiliary bus bars for control supply shall be segregated from main bus bars. The control supplies shall be monitored.
- xii) Contractor shall fully co-ordinate overload and short circuit tripping of breaker with upstream and down stream breakers/ fuses/ MCCBs motor starters. Various equipments shall meet requirement of Type-II class of coordination as per IEC.
- xiii) All relays and timers shall operate on available DC supply and not have any inbuilt batteries. They shall be provided with hand-reset operation indicator (flags) or LEDs with push buttons for resetting.
- xiv) All meters/ instrument shall be flush mounted on front panel, at least 96 mm² size with 90⁰ linear scales and accuracy class of 2.0.
- xv) All motors of 30kW and above shall have an ammeter. Bus-section shall have bus VT, voltmeter with selector switch, and other relay and timers required for protection. Adequate control and selector switches, push buttons and indicating lamps shall be provided. Thermostatically controlled space heaters with switches shall be provided to prevent condensation.
- xvi) All motors are required to have an emergency stop push button near the motor.
- xvii) In case of remote controlled breaker panels, following shall be provided :

Each feeder shall have local/ remote selector switch. Closing from local shall be possible only in test position whereas closing from remote shall be possible in either service or test position. Tripping from local shall be possible only when local/ remote selector switch is in local position. Tripping from remote shall be either breaker in service position or selector switch being in remote position.



- xviii) Suitable self powered transducers as per IS : 12784 Part - I for feeding signals to panel mounted electrical meters (ammeters, voltmeters, VAR meters and watt meters etc.) and DCCMIS shall be provided.

Transducers shall be tested as per IEC:600298 or impulse test etc and short circuit withstand capability as per ANSI C 37.90a, 1989

Transducers shall be provided with two decoupled 4-20mA output signals, one for meter and one for DDCMIS. Current limiting features shall be provided for all the transducers.

- xix) Transducers

- a) Current transducers

- Input 0-1 A (CT secondary)
- Rated frequency 50 Hz
- Output 4-20 mA (2 Nos. decoupled) for meter/ DDCMIS
- Accuracy 0.5%

- b) Bus voltage transducers

- Input 110V, 50 Hz (from VT secondary)
- Output 4-20 mA (2 Nos. de-coupled)
- Accuracy 0.5%

- xx) Necessary hardware shall be provided in the switchgear panel like coupling relays (24VDC with maximum burden of 2.5VA), auxiliary relays in addition to current/ bus-voltage transducers (4-20 mA, dual output) etc. to effect interlocks, exchange information/ status and exercise control from remote.

- f) The motor feeders for the following essential auxiliaries shall have contactors with delayed drop- out feature adjustable up to three seconds.

- i) Seal air fans
- ii) Ignitor air fans
- iii) Scanner air fans
- iv) Stator water cooling pump
- v) Barring gear/ Jacking oil pump/ Auxiliary oil pump
- vi) Lubricating oil pumps of various unit auxiliaries
- vii) Hydrogen seal oil pump
- viii) Centrifugal fan of hydrogen seal oil pump
- ix) Lubricating oil system vapour fans
- x) Bearing cooling water pumps
- xi) AC emergency lubricating oil pumps/Auxiliary lubricating oil pumps



- xii) Air Pre- heaters
- xiii) Control air compressors and Service air compressors
- xiv) Any other drive recommended by Boiler, Turbine and Generator manufacturer

5.9.7 Protection

i) 415V AC and 220V DC Incomers

- a) Time graded short circuit protection on incoming supply feeder circuit breakers to main switchgears (PCCs and MCCs)
- b) Instantaneous over-current protection on all outgoing feeders
- c) Under- voltage protection for 415V bus
- d) Sensitive earth fault detectors shall be provided in DC system to annunciate earth faults

ii) 415 Volts motor feeders

- 1) Contactor controlled motor feeders (Motors up to 200 kW)
 - i) Instantaneous short circuit protection on all phases through HRC cartridge type fuses rated for 80 kA rms (prospective breaking capacity at 415V).
 - ii) Thermal overload protection
 - iii) Single phasing protection for motors protected by fuses
- 2) Breaker controlled motors feeders (motors rated above 200 kW)
 - i) Instantaneous short circuit protection on all phases
 - ii) Overload protection on two phases
 - iii) Over load alarm on third phase
 - iv) Earth fault protection
 - v) Under voltage protection
 - vi) Hand reset lockout relay with a blue lamp for monitoring

5.9.8 Design and constructional features

- a) All 415V switchgears, AC and DC distribution boards (DBs), etc shall have following features :



- i) Shall be of metal enclosed, indoor, floor mounted and free standing type.
- ii) All frames and load bearing members shall be fabricated using mild steel structural sections or pressed and shaped cold rolled sheet steel of thickness not less than 2mm.
- iii) Frame shall be enclosed in cold rolled sheet steel of thickness not less than 2mm (CR). Doors and covers shall also be of cold rolled sheet steel of thickness not less than 1.6 mm. Stiffeners shall be provided wherever necessary. Removable gland plates of thickness 3mm (hot/cold rolled sheet steel) or 4 mm (non-magnetic material) shall be provided for all panels.
- iv) For motors above 160kW, remote controlled electrical circuit breakers, and for smaller motors, switch-fuse contactor feeders shall be provided. The other outgoing feeders would be switch-fuse units or moulded case circuit breakers.
- v) The switchboards/ MCC/ DBs of 1600A and above rating shall be of DOP IP42 and of IP52 for less than 1600A rating.
- vi) All 415V switchgears, MCC's, AC and DC distribution boards etc. shall be painted by powder coating process.

Paint shade for complete panels excluding end covers shall be RAL9002 and RAL5012 for extreme end covers of all boards.

- vii) Minimum air clearance in air between phases and phase-earth shall be 25 mm for busbars and cable terminations. For all other components, the Clearances shall be at least 10mm. Wherever above is not possible except for horizontal and vertical busbars, insulation shall be provided by anti tracking sleeving or barriers. However for horizontal and vertical busbars, clearances specified above shall be maintained even when busbars are insulated/ sleeved. In case of DCDBs/ fuse boards, the busbar system shall be insulated or physically segregated with barriers to prevent interpole short circuit.
- viii) All current and voltage transformers as required for metering and protection specified shall be completely encapsulated, cast resin insulated type. Incomers from transformers shall have CTs for transformer Restricted Earth Fault (REF) protection. All current and voltage transformers as required for metering and protection specified shall be completely encapsulated cast resin insulated type. Incomers from transformers shall have CTs for transformer restricted earth fault protection. The accuracy shall be as follows:

	<u>CTs</u>	<u>VTs</u>
Protection	5P20	3P
Metering	1.0	1.0
REF	PS	



- b) Indicating lamps shall be cluster LED type.

5.9.9 Spare feeders - 20% spare feeders with atleast one of each type and rating shall be provided in each switchgear.

5.9.10 415V Non-segregated phase busduct

- i) The section of three phase and neutral metal enclosed non segregated phase bus duct shall be rectangular. The design of the bus duct enclosures shall be of sturdy construction such that it will withstand the internal or external forces resulting from the various operating conditions.
- ii) The entire bus duct shall be designed for dust, vermin and weather proof construction. A suitable aluminium sheet flange-protection hood shall be provided to cover all outdoor bus duct enclosure joints to facilitate additional protection against rain water ingress. All horizontal runs of bus duct shall have a suitable sloped enclosure top to prevent retention of water for both indoor and out door portion of bus ducts. Bus duct enclosure shall have a degree of protection of IP-55.
- iii) The inside of the bus enclosure may be treated with black paint to enable efficient heat dissipation. The matt paint used shall be suitable for temperature experienced during continuous loading of the bus conductor.
- iv) Enclosures shall be provided with flanged ends with drilling dimensions to suit the flanges at the switchgear and transformer terminals.
- v) The synthetic/ neoprene gaskets shall be provided so as to satisfy the operating conditions imposed by temperature, weathering, durability etc. Flange gaskets shall be provided at the equipment terminal connections.
- vi) Necessary earthing arrangement as applicable shall be provided with clamps to receive station earthing bus. This shall be a GI strip of adequate size, continuously running along the busduct and shall be earthed at both ends. Bus duct enclosures shall be bolted type.
- vii) The material of the conductor shall be aluminium. The bus bars shall be rated in accordance with the service conditions and the rated continuous and short time current ratings.
- viii) All steel structures required for bus duct support shall be hot dip galvanised.



ix) **Technical Data**

a)	Type	Non-segregated
b)	1 minute power frequency withstand voltage	2.5 kV
c)	Maximum short circuit withstand current	45kA/ 50kA for 1 second
d)	Momentary dynamic current withstand	94.5/ 105kA (Peak)



5.10 POWER AND CONTROL CABLES

All 11kV, 3.3kV, 415V power cables, control cables and DC cables required to connect unit auxiliaries shall be supplied.

5.10.1 Codes and standards

All cables to be supplied shall conform to the latest revisions of IS or any other international standards acceptable to purchaser. Some of the Indian Standards/ IEC considered relevant to the cables are given below:

IS:1554 (Part-I)	PVC insulated (heavy duty) electric cables for working voltage up to and including 1100 V.
IS:1554 (Part-II)	PVC insulated (heavy duty) electric cables for working voltage from 3.3kV upto and including 11kV.
IS:7098 (Part-II)	XLPE insulated PVC sheathed cables for working voltages from 3.3 kV upto and including 33kV.
IS:3961	Recommended current ratings for cables.
IS:8130	Conductors for insulated electric cables and flexible cords.
IS:5831	PVC insulation and sheath of electric cables.
IS:2982	Copper conductor in insulated cables and cords.
IS:3975	Mild steel wires, strips and tapes for armouring cables
IS:5609	Specification for low frequency wires and cables with PVC insulation and PVC Sheath.
IS:6380	Spec. of elastomeric insulation of sheath of electric cables.
IS:434(I and II)	Specification for rubber insulation cables
IEC:540	The methods for insulations and sheaths of electric cables and cords (elastomeric and thermoplastic compounds).
IEC:230	Impulse tests on cables and their accessories.
IEC:60	High voltage test techniques.
IEC:287	Calculations of the continuous current rating of cables (100% load factor).
IEC:288	Nominal cross-sectional area and composition of conductor of insulated cables.
IEC:502	Extruded solid dielectric insulated power cables for rated voltages from 1.00 kV upto 30 kV.
NEMA-WC-5	Thermoplastic insulated wires and cables for transmission and distribution of electrical energy.
IEEE:383	Standard for type test for class IE electric cables, filled splices and connections for nuclear power generation stations
IEC: 332-1	Test on electric cables under fire conditions.
ASTM-D-2843	Standard test method for density of smoke from burning/ decomposition of plastics.
ASTM-D-2863	Test for determination of Oxygen Index.
IEC-754-I	Test method for acid gas generation.
IEC-331	Fire resisting characteristics of electric cables.
SVENSK Standard	SS- 4241475 Class F3
BICC Hand Book	For cables in fire regarding temperature index-chapter-6

5.10.2 Design criteria

- i) The cable shall be suitable for installation in a tropical monsoon area having a hot humid climate. The reference ambient temperature to be considered for the purpose of this specification is 50⁰C.
- ii) The derating factor for the various conditions of installation including the following shall be considered while choosing the conductor size and calculations shall be submitted for purchaser's approval:
 - a) Maximum ambient air temperature.
 - b) Maximum ground temperature
 - c) Depth of laying wherever applicable
 - d) Grouping of cables
- iii) The allowable voltage drop at terminal of the connected equipment shall be maximum 2.5% at full load while choosing the conductor size and calculations shall be submitted for purchaser's approval. In case of squirrel cage induction motors, the cable size shall be so chosen that the motor terminal voltage does not fall below 85% of the rated voltage, at the time of starting.
- iv) The maximum continuous conductor temperature and the maximum allowable conductor temperature during short circuit are to be taken as 70⁰C and 160⁰C respectively in case of PVC insulated cables and 90⁰C and 250⁰C respectively in case of XLPE insulated cables.
- v) For 415V power cables of size above 35 mm², XLPE insulated cables shall also be acceptable. The minimum size of all 11kV (UE), 3.3kV (UE) grade power cables and 415V power cables connected to circuit breakers shall be chosen taking into account the following factors:
 - a) Fault level due to system contribution.
 - b) Fault contribution of running motors.
 - c) Expected time up to which motor contribution persists.
 - d) Maximum time for fault clearance (i.e. operating time of the back up protection relays plus the time of operation of the circuit breakers).
 - e) Full load current of the circuit.
- vi) The cables shall be capable of continuous satisfactory operation under a power supply system frequency variation of (±) 5%, voltage variation of (±) 10% and combined frequency and voltage variation of 10% (absolute sum).



- vii) The cables shall in general comply with the requirements of the latest revision of IS 7098 (Part-II) for the 11 kV (UE), 3.3kV grade, XLPE insulated cables and IS-1554 (Part –I) for the LT PVC power and control cables or the relevant IEC International Standard unless otherwise specified in this specification. The design, manufacture, installation, testing and performance of the cables, shall comply with the latest revisions of IS/ IEC/ NEMA/ ASTM Standard and the most stringent conditions specified in these specification shall be applicable.

5.10.3 General technical requirements

- i) Type of cable

The cable shall be multi-core/ single core (XLPE), PVC and any polymeric/ elastomeric insulation type as specified.

- ii) Conductor

The cable conductor shall be made from standard copper/ Aluminum to form compact conductor having a resistance within the limits specified.

All the cables of size 25mm² and above shall have sector shaped conductors. The minimum no. of strands in conductor shall be 7 (seven) except as otherwise specified. Power cables shall be of stranded aluminum conductor with a minimum size 6mm² and the control cables shall be stranded copper (electrolytic) conductor with a minimum size of 2.5 mm².

- iii) Conductor Shield

The conductor having a semi-conducting screen shall ensure perfectly smooth profile and avoid stress concentration. The conductor screen shall be extruded in the same operation as the insulation, the semi-conducting polymer shall be cross-linked for XLPE cables.

- iv) Insulation

The insulation of the cable shall be extruded type and shall be designed and manufactured for the specified system voltage. The manufacturing process shall ensure that insulation shall be free from voids. The insulation shall withstand mechanical and thermal stresses under steady state and transient operating conditions. The extrusion method should give a very smooth interface between semi conducting screen and insulation. The insulation of the cables shall be of high standard quality. The minimum volume resistivity of the PVC insulation of all the PVC insulated cables shall be 1x10¹⁴ ohm-cm at 27°C and 1x10¹¹ ohm-cm at 70°C.

- v) Insulation shield

In XLPE cables, to confine electrical field to the insulation, a non-magnetic semi-

conducting shield shall be put over the insulation. The insulation shield shall be extruded in the same operation as the conductor shield and the insulation by triple extrusion/process. The XLPE cable insulation shield shall be strippable. Metallic screening as given in this specification for the various power and control and special cables shall be provided.

vi) Inner Sheath

The sheath shall be suitable to withstand the site conditions and the desired temperature. It shall be of adequate thickness and applied by a continuous process to produce a sheath of consistent quality free from all defects. PVC sheath shall be extruded.

vii) Armour

Hard drawn aluminum wire armouring/ galvanized steel tape/ wire armouring shall be used for single core and multi-core cable respectively. Cables should be un-armoured wherever indicated.

The hard drawn aluminium wire for armour shall be of H₄ grade, as per IS-8130 (having tensile strength above 150 N/mm²) The diameter of the aluminium wire shall be as per the table for the dimensions of the galvanized steel wire armour given in the relevant standard.

viii) Serving/ outer sheath

Extruded PVC serving as per IS: 5831 or as specified otherwise shall be applied over the armouring with suitable additives to prevent attack by rodent and termites. All serving must be given anti-termite treatment.

5.10.4 Constructional requirements

- i) Cable shall have suitable fillers laid up with the conductors to provide a substantially circular cross section before the sheath is applied. Fillers shall be suitable for the operating temperature of the cable and compatible with the insulating material. All materials shall be new, unused and of finest quality. Workmanship shall be neat, clean and of highest grade.
 - a) 11 kV system power cables - The cable shall be 11kV/11kV (unearthed) grade, heavy duty, stranded aluminium conductor, XLPE insulated, provided with conductor screening and insulation screening, galvanized steel wire/strip armoured, flame retardant low smoke (FRLS) extruded PVC of type ST2 outer sheathed.
 - b) 3.3 kV system power cables - The cable shall be 3.3kV/3.3kV (unearthed) grade, heavy duty, stranded aluminium conductor, XLPE insulated, galvanized steel wire/ strip armoured, flame retardant low smoke (FRLS) extruded PVC of type ST2 outer sheathed.



- c) 415V system power cables - The cable shall be 1.1kV, grade, heavy duty, stranded aluminium conductor, PVC Type-A Insulated galvanized steel wire/strip armoured, flame retardant low smoke (FRLS) extruded PVC type ST1 outer sheathed.
 - d) Control cables - The cable shall be 1.1kV grade, heavy duty, stranded copper conductor, PVC Type-A insulated, galvanized steel wire / strip armoured, flame retardant low smoke (FRLS) extruded PVC of Type-ST1 outer sheathed.
 - e) Generator excitation system cables - The cables shall be 3.3kV grade, heavy duty, stranded copper conductor, insulated with heat resistant PVC of Type-C, hard drawn aluminium wire armoured, flame retardant low smoke (FRLS) extruded PVC Type-ST2 outer sheathed.
- ii) Special properties : All the above cables shall be conforming to the relevant Indian/ IEC standard in general, with the following special properties:
- a) Oxygen Index of the outer sheath shall not be less than 29, when tested as per ASTM-D-2863.
 - b) Temperature Index of the outer sheath shall not be less than 250°C, when tested as per ASTM-D-2863.
 - c) Halogen acid contents in outer sheath shall not be more than 20%, when tested as per IEC-60754.
 - d) The maximum smoke density in percent light absorption should not exceed 60% in case of PVC compound and 20% in case of fire survival cables, when tested as per ASTM-D-2843.
 - e) Swedish chimney test as per SS-4241475 class F3 and ladder test for flammability as per IEEE-383.
- iii) Fire survival cables : The cable shall be of copper conductor and comply with IEC-60331 in addition to the above requirement. Also the halogen acid contents in outer sheath shall not be more than 2% when tested and per IEC-60754 and the smoke density in percent light absorption shall not exceed 20% when tested as per ASTM-D-2843. Cables required for the following systems shall be Fire survival type :
- a) DC emergency lube oil pumps
 - b) DC seal oil pump
 - c) DC emergency lighting cables for main building.
 - d) Batteries to chargers and DC distribution boards.



- e) Turbine lub oil pumps
- f) Jacking oil pumps
- g) Emergency turbine trip by push button in control room
- h) Boiler turbine : Generator inter-trip which includes the inter connecting cables between
 - Boiler master fuel trip and turbine trip relays
 - Generator trip relays and turbine trip relays
 - Generator trip relays and 400kV circuit breaker
 - Generator trip relays and generator field breaker
 - Generator trip relays and UAT breakers

5.10.5 Identification of cores

The insulated cores of HT and LT power cables shall be identified by coloured code. The control cables shall have identification by means of indelible printing of numbers of its cores at intervals not more than 75 mm. At least 20% cores shall be kept as spares in the multi-core control cables.

5.10.6 Arrangement of cables

As far as feasible, separate cables shall be provided for circuits of different plant and auxiliaries, for circuits of different voltages, and for circuit used separately. Power, control and instrumentation circuit shall invariably be taken through different routes, which shall not be laid together on the same cable trays.

5.10.7 Drums lengths

Drum lengths of the cables shall be so chosen that straight through joints are eliminated. However, the drum lengths shall not be less than the following lengths:

- i) 11kV grade power cables 500 M
- ii) 1.1kV grade power / Fire survival cables etc.
 - Including and above 400 mm² size 400 M
 - Below 400mm² size 500 M
- iii) 1.1kV grade control and instrumentation cables 1000M

5.11 INSTALLATION OF CABLES, EARTHING SYSTEM AND LIGHTNING PROTECTION SYSTEM

The cable trays, and accessories, supports, conduits, cable glands, lugs, ferrules, tags, clamps and other accessories for installation of cables in cable galleries, trenches etc. for unit auxiliaries; earthing system network/ earth mat including interconnections; and lightning protection of main and service buildings and other tall structures shall be provided.

5.11.1 Codes and standards

All work shall be carried out as per the following standards/ codes as applicable.

IS:513	Cold rolled low carbon steel sheets and strips.
IS:802	Code of practice for the use of Structural Steel in Overhead transmission Line Towers.
IS:1079	Hot Rolled carbon steel sheet and strips
IS:1239	Mild steel tubes, tubulars and other wrought steel fittings
IS:1255	Code of practice for installation and maintenance of power cables upto and including 33 KV rating
IS:1367 Part-13	Technical supply conditions for threaded Steel fasteners. (Hot dip galvanized coatings on threaded fasteners).
IS:2147	Degree of protection provided by enclosures for low voltage switchgear and control gear
IS:2309	Code of Practice for the protection of building and allied structures against lightning.
IS:2629	Recommended practice for hot dip galvanising of iron and steel
IS:2633	Method for testing uniformity of coating on zinc coated articles.
IS:3043	Code of practice for Earthing
IS:3063	Fasteners single coil rectangular section spring washers.
IS:6745	Methods for determination of mass of zinc coating on zinc coated iron and steel articles.
IS:8308	Compression type tubular in- line connectors for aluminium conductors of insulated cables
IS:8309	Compression type tubular terminal ends for aluminium conductors of insulated cables.
IS:9537	Conduits for electrical installation.
IS:9595	Metal arc welding of carbon and carbon manganese steels- recommendations.
IS:13573	Joints and terminations for polymeric cables for working voltages from 6.6kv upto and including 33kv performance requirements and type tests.
BS:476	Fire tests on building materials and structures
IEEE:80	IEEE guide for safety in AC substation grounding
IEEE:142	Grounding of Industrial and commercial power systems
DIN 46267	Non tension proof compression joints for Aluminium conductors.
DIN 46329	Cable lugs for compression connections, ring type, for Aluminium conductors
VDE 0278	Tests on cable terminations and straight through joints
BS:6121	Specification for mechanical Cable glands for elastomers and plastic insulated cables.



5.11.2 Design and Constructional Features

i) Inter Plant Cabling

Interplant cabling for main routes shall be laid along overhead trestles/duct banks. However, from tap-offs, same can be through shallow trenches. In case of Duct banks, pull-pits shall be filled with sand and provided with a PCC covering. Directly buried cables, if essential, shall not have concentration of more than 4 cables in one route.

ii) Transformer yard

In transformer yard area, cables shall be laid in RCC concrete trenches with RCC covers. The main cable routes coming out from Main plant building and crossing the Transformer yard shall be laid in overhead trestles/ duct banks. Minimum clear height of trestle shall be 3 m and for Rail/road crossing, it shall be as per rail/road crossing norms.

iii) False floors are not to be provided for cabling purpose.

iv) Cable entry : Cable entry from outdoor underground/ cable routes to the buildings, if any, shall be above the finished floor level of the building.

v) Trenches : PCC flooring of built up trenches shall be sloped for effective drainage with sump pits and sump pumps.

vi) No sub zero level cable vault/ trenches shall be provided below control building/ switchgear rooms in main plant areas.

5.11.3 Equipment Description

i) **Cable trays, fittings and accessories**

a) Cable trays shall be ladder/perforated type as specified complete with matching fittings (like brackets, elbows, bends, reducers, tees, crosses, etc.) accessories (like side coupler plates, etc. and hardware (like bolts, nuts, washers, GI strap, hook etc.) as required. Cable tray shall be ladder type for power and control cables and perforated for instrumentation cables.

b) Cable trays, fittings and accessories shall be fabricated out of rolled mild steel sheets free from flaws such as laminations, rolling marks, pitting etc. These (including hardware) shall be hot dip galvanized as per relevant IS.

c) Cable trays shall have standard width of 150 mm, 300 mm and 600 mm and standard lengths of 2.5 metre. Minimum thickness of mild steel sheets used for fabrication of cable trays and fittings shall be 2 mm. The thickness of side coupler plates shall be minimum 3 mm .



- d) Cable troughs shall be required for branching out few cables from main cable route. These shall be U-shaped, fabricated of mild steel sheets of minimum thickness 2 mm and shall be hot dip galvanized as per relevant IS. Troughs shall be standard width of 50 mm and 75 mm with depth of 25 mm

ii) Support system for cable trays

- a) Cable tray support system shall be pre-fabricated.
- b) Support system for cable trays shall essentially comprise of the two components i.e. main support channel and cantilever arms. The main support channel shall be of two types: i) having provision of supporting cable trays on one side and ii) having provision of supporting cable trays on both sides. The support system shall be as follows :
- Cable supporting steel work for cable racks/cables shall comprise of various channel sections, cantilever arms, various brackets, clamps, floor plates, all hardwares such as lock washers, hexagon nuts, hexagon head bolt, support hooks, stud nuts, hexagon head screw, channel nut, channel nut with springs, fixing studs, etc.
 - The system shall be designed such that it allows easy assembly at site by using bolting. All cable supporting steel work, hardwares fittings and accessories shall be prefabricated factory galvanized.
 - The main support and cantilever arms shall be fixed at site using necessary brackets, clamps, fittings, bolts, nuts and other hardware etc. to form various arrangements required to support the cable trays. Welding of the components shall not be allowed. However, welding of the bracket (to which the main support channel is bolted) to the overhead beams, structural steel, insert plates or reinforcement bars will be permitted. Any cutting or welding of the galvanized surface shall be brushed and red lead primer, oil primer and aluminium paint shall be applied.
 - All steel components, accessories, fittings and hardware shall be hot dip galvanized after completing welding, cutting, drilling and other machining operation.
 - The main support channel and cantilever arms shall be fabricated out of minimum 2.5 thick rolled steel sheet conforming to IS.
 - Cantilever arms of 300 mm, 600 mm and 750 mm in length are required. The arm portion shall be suitable for assembling the complete arm assembly on to component constructed of standard channel section. The back plate shall allow sufficient clearance for fixing bolt to be tightened with tray in position.



iii) Pipes, Fittings and accessories

- a) Pipes offered shall be complete with fittings and accessories (like tees, elbows, bends, check nuts, bushings, reducers, enlargers, coupling caps, nipples etc.) The size of the pipe shall be selected on the basis of maximum 40% fill criteria
- b) GI Pipes shall be of medium duty as per IS:1239.
- c) Duct banks shall be high density PE pipes encased in PCC (10% spare of each size, subject to minimum one) with suitable water-proof manholes.

iv) Junction boxes

- a) Junction Boxes with IP:55 degree of protection, shall comprise of a case with hinged door constructed from cold rolled sheet steel of minimum thickness 2 mm. Top of the boxes shall be arranged to slope towards rear of the box. Gland plate shall be 3 mm thick sheet steel with neoprene/synthetic rubber gaskets. All junction boxes shall be of adequate strength and rigidity, hot dip galvanized as per relevant IS, and suitable for mounting on wall, columns, structures etc. The boxes shall include brackets, bolts, nuts, screws M8 earthing stud etc. required for installation
- b) Terminal blocks shall be 650 volts grade, rated for 10 Amps and in one piece moulding. It shall be complete with insulating barriers, Klip-on-type terminals and identification strips. Marking on terminal strip shall correspond to the terminal numbering on wiring diagrams. It shall be Elmex type CSLT-1 with insulating material of Melamine conforming to ESI Standard 12.1 or equivalent. Terminal block shall be suitable for terminating 2 wires of 2.5mm² on both sides arranged to facilitate easy termination

v) Terminations and straight through joints

- a) Termination and jointing kits for 11kv/ 3.3 kV grade XLPE insulated cables shall be of proven design and make which have already been extensively used and type tested. Termination kits and jointing kits shall be pre-moulded type, tapex type or heat shrinkable type. 11kV/ 3.3kV grade joints and terminations shall be type tested as per IS:13573. Critical components used in cable accessories shall be of tested and proven quality as per relevant product specification/ ESI specification. The kit shall be complete with the aluminium solderless crimping type cable lugs and ferrule as per DIN standard.
- b) Straight through joint and termination shall be capable of withstanding the fault level for 11 kV and 3.3kV system.

c) 1.1 kV grade straight through joints shall be of proven design.

vi) Cable glands

Cable shall be terminated using double compression type cable glands. Cable glands shall conform to BS:6121 and be of robust construction capable of clamping cable and cable armour (for armoured cables) firmly without injury to insulation. Cable glands shall be made of heavy duty brass machine finished and nickel chrome plated. Thickness of plating shall not be less than 10 micron. All washers and hardware shall also be made of brass with nickel chrome plating. Rubber components shall be of neoprene and of tested quality. Necessary cable dimensions shall be furnished to the successful bidder.

vii) Cable lugs/ ferrules

Cable lugs for power cables shall be Aluminium solderless crimping type conforming to IS:8309 suitable for aluminium compacted conductor cables. Cable lugs and ferrules for control cables shall be tinned copper conforming to IS:8309. The cable lugs for control cables shall be provided with insulating sleeve and shall suit the type of terminals provided on the equipments.

viii) Trefoil clamps

Trefoil clamps for single core cables shall be pressure die cast aluminum or fibre glass or nylon and shall include necessary fixing accessories like G.I. nuts, bolts, washers, etc. Trefoil clamps shall have adequate mechanical strength to withstand the forces generated by the system short circuit current of 105kA peak.

ix) Cable clamps and straps

The cable clamps required to clamp multicore cables on vertical run shall be made up of Aluminium strip of 25x3 mm size. For clamping the multicore cables, self-locking, de-interlocking type nylon clamps/ straps shall be used. The clamps/ straps shall have sufficient strength and shall not get affected by direct exposure to sun rays and outdoor environment

x) Receptacles

Receptacles boxes shall be fabricated out of MS sheet of 2mm thickness and hot dipped galvanized or of die-cast aluminium alloy of thickness not less than 2.5 mm. The boxes shall be provided with two nos. earthing terminals, gasket to achieve IP55 degree of protection, terminal blocks for loop-in loop-out for cable of specified sizes, mounting brackets suitable for surface mounting on wall/ column/ structure, gland plate etc. The ON-OFF switch shall be rotary type heavy duty, double break, AC23 category, suitable for AC supply. Plug and Socket shall be shrouded Die-cast aluminium. Socket shall be provided with lid safety cover. Robust mechanical interlock shall be provided such that the switch can be put ON only when the plug is fully engaged and plug can be withdrawn only when the switch is in OFF position. Also cover can be opened only when the

switch is in OFF position. Wiring shall be carried out with 1100 V grade PVC insulated stranded aluminium/ copper wire of adequate size. The Terminal blocks shall be of 1100V grade.

xi) Galvanizing

- a) Galvanizing of steel components and accessories shall conform to IS:2629 and IS:2633. Additionally galvanizing shall be uniform, clean smooth, continuous and free from acid spots
- b) The amount of zinc deposit over threaded portion of bolts, nuts, screws and washers shall be as per IS:1367. The removal of extra zinc on threaded portion of components shall be carefully done to ensure that the threads shall have the required zinc coating on them as specified

xii) Welding

The welding shall be carried out in accordance with IS:9595. All welding procedures and welders qualification shall also be followed strictly in line with IS:9595

5.11.4 Installation

i) Cable tray and support system installation

- a) Cables shall run in cable trays mounted horizontally or vertically on cable tray support system which in turn shall be supported from floor, ceiling, overhead structures, trestles, pipe racks, trenches or other building structures. All cable trays shall be in vertical configuration in boiler and ESP areas.
- b) Horizontally running cable trays shall be clamped by bolting to cantilever arms and vertically running cable trays shall be bolted to main support channel by suitable bracket/ clamps on both top and bottom side rails at an interval of 2000 mm. For vertical cable risers/shafts cable trays shall be supported at an interval of 1000mm. Fixing of cable trays to cantilever arms or main support channel by welding shall not be accepted.
- c) The cantilever arms shall be positioned on the main support channel with a minimum vertical spacing of 300 mm unless otherwise indicated in the relevant tray layout drawings
- d) All cable way sections shall have identification, designations as per cable way layout drawings and painted/stenciled at each end of cable way and where there is a branch connection to another cable way. Minimum height of letter shall be not less than 75 mm. For long lengths of trays, the identification shall be painted at every 10 meter. Risers shall additionally be painted/ stenciled with identification numbers at every floor.



- e) In certain cases it may be necessary to site fabricate portions of trays, supports and other non standard bends where the normal prefabricated trays, supports and accessories may not be suitable. In such cases the Contractor shall fabricate at site suitable sections of trays, supports and accessories to make the installation complete for the specific purpose after obtaining Project Manager's prior approval, which shall be neat in appearance and shall match with the prefabricated sections in the dimensions. They shall be applied with one coat of red lead primer, one coat of oil primer followed by two finishing coats of aluminium paint.

ii) Conduits/ Pipes/ Ducts installation

- a) All openings in the floor/ roof/ wall/ cable tunnel/ cable trenches made for conduit installation shall be sealed and made water proof.
- b) GI pull wire of adequate size shall be laid in all conduits before installation. Metallic conduit runs at termination shall have two lock nuts wherever required for junction boxes etc.
- c) Conduit runs/sleeves shall be provided with PVC bushings having round edge at each end. All conduits/ pipes shall have their ends closed by caps until cables are pulled. After cables are pulled, the ends of conduits/ pipes shall be sealed with Glass-wool/ Cement Mortar/ Putty to prevent entrance of moisture and foreign material
- d) Exposed conduit/ pipe shall be adequately supported by racks, clamps, straps or by other approved means. Conduits / pipe support shall be installed square and true to line and grade with an average spacing between the supports as given below, unless specified otherwise

Conduit/ pipe size (dia)	Spacing
Upto 40 mm	1.0 m
50 mm	2.0 m
65-85 mm	2.5 m
100 mm	3.0 m

iii) Junction boxes installation

Junction boxes shall be mounted at a height of 1200mm above floor level or as specified in the drawings or as decided by Project Manager and shall be adequately supported/mounted on masonry wall by means of anchor fasteners/ expandable bolts or shall be mounted on an angle, plate or other structural supports fixed to floor, wall, ceiling or equipment foundations.

iv) Cable installation

- a) Cable installation shall be carried out as per IS:1255 and other applicable standards. Cable drums shall be unloaded, handled and stored in an approved manner on hard and well drained surface so that they may not sink. In no case shall a drum be stored flat i.e. with flange horizontal. Rolling of drums shall be avoided as far as possible. For short distances, the drums may be rolled provided they are rolled slowly and in proper direction as marked on the drum. In absence of any indication, the drums may be rolled in the same direction as it was rolled during taking up the cables. For un-reeling the cable, the drum shall be mounted on suitable jacks or on cable wheels and shall be rolled slowly so that cable comes out over the drum and not from below. All possible care shall be taken during unreeling and laying to avoid damage due to twist, kink or sharp bends. Cable ends shall be provided with sealed plastic caps to prevent damage and ingress of moisture.
- b) While laying cable, ground rollers shall be used at every 2 metre interval to avoid cable touching ground. The cables shall be pushed over the rollers by a gang of people positioned in between the rollers. Cables shall not be pulled from the end without having intermediate pushing arrangements. Pulling tension shall not exceed the values recommended by cable manufacturer. Selection of cable drums for each run shall be so planned so as to avoid using straight through joints. Care should be taken while laying the cables so as to avoid damage to cables.
- c) Cables shall be laid on cable trays strictly in line with cable schedule furnished.
- d) Power and control cables shall be laid on separate tiers. The laying of different voltage grade cables shall be on different tiers according to the voltage grade of the cables. In horizontal tray stacks, HT cables (11kV) shall be laid on topmost tier and cables of subsequent lower voltage grades on lower tiers of trays. Single core cable in trefoil formation shall be laid with a distance of four times the diameter of cable between trefoil center lines and clamped at every two metre. All multi-core cables shall be laid in touching formation. Power and control cables shall be secured fixed to trays/ support with self locking type nylon cable straps with de-interlocking facilities. For horizontal trays arrangements, multi-core power cables and control cables shall be secured at every five meter interval. For vertical tray arrangement, individual multi-core power cables and control cables shall be secured at every one meter by nylon cable strap. After completion of cable laying work in the particular vertical tray, all the control cables shall be binded to trays/ supports by aluminium strips at every five meter interval and at every bend.
- e) Bending radii for cables shall be as per manufacturer's recommendations and IS:1255.



- f) Where cables cross roads/rail tracks, the cables shall be laid in hume pipe/ PVC pipe.
- g) Joints for less than 250 Meters run of cable shall not be permitted.
- h) In each cable run some extra length shall be kept at suitable point to enable one LT (415V system) / two HT (11kV, 3.3kV) straight through joints to made, should the cable develop fault at a later stage. Control cable termination inside equipment enclosure shall have sufficient lengths so that shifting of termination in terminal blocks can be done without requiring any splicing.
- i) Wherever few cables are branching out from main trunk route troughs shall be used.
- j) The installation work shall be carried out in a neat workman like manner and areas of work shall be cleaned of all scraps, water, etc. after the completion of work in each area every day. RCC/ Steel trench covers shall be replaced after the installation work in a particular area is completed or when further work is not likely to be taken up for some time.
- k) **Separation** - At least 300mm clearance shall be provided between :
- HT power and LT power cables,
 - LT power and LT control/ instrumentation cables,
- l) **Segregation**
- Segregation means physical isolation to prevent fire jumping.
 - All cables associated with the unit shall be segregated from cables of other units.
 - Interplant cables of unit critical drives shall be segregated in such a way that not more than half of the drives are lost in case of single incident of fire. Power and control cables for AC drives and corresponding emergency AC or DC drives shall be laid in segregated routes. Cable routes for one set of auxiliaries of same unit shall be segregated from the other set.
- m) Minimum number of spare cores required to be left for interconnection in control cables shall be as follows :

No. of cores in cable	No. of spare cores
2C, 3C	NIL
5C	1
7C-10C	2
14C and above	3

n) **Cable fire sealing**

Wherever the cables pass through walls/ floors, fire proof cable penetration seals rated for two hours shall be provided. This shall be by suitable block system using individual blocks with suitable framework or by silicon RTV foaming system. In case foaming system is offered, damming board, if used, shall not be considered for fire rating criteria. Any of the system offered shall be of proven type as per BS:476 (Part-20) or equivalent standard.

o) **Directly buried cables**

- Cable trenches shall be constructed for directly buried cables. Construction of cable trench for cables shall include excavation, preparation of sieved sand bedding, riddled soil cover, supply and installation of brick or concrete protective covers, back filling and compacting, supply and installation of route markers and joint markers. Laying of cables and providing protective covering shall be as per IS:1255.

- RCC cable route and RCC joint markers shall be provided wherever required. The voltage grade of the higher voltage cables in route shall be engraved on the marker. Location of underground cable joints shall be indicated with cable marker with an additional inscription "Cable Joint". The marker shall project 150 mm above ground and shall be spaced at an interval of 30 meters and at every change in direction. They shall be located on both sides of road crossings and drain crossings. Top of cable marker/joint marker shall be sloped to avoid accumulation of water/dust on marker.

p) Cable tags shall be provided on all cables at each end (just before entering the equipment enclosure), on both sides of a wall or floor crossing, on each duct/conduit entry, and at every 20 meters in cable tray/trench runs. Cable tags shall also be provided inside the switchgear, motor control centers, control and relay panels etc. where a number of cables enter together through a gland plate. Cable tag shall be of rectangular shape for power cables and control cables. Cable tag shall be of 2 mm thick aluminum with number punched on it and securely attached to the cable by not less than two turns of 20 SWG GI wire conforming to IS:280. Alternatively, cable tags made of nylon, cable marking ties of 'TY-CAB' or equivalent type with cable number heat stamped on the cable tags may also be provided.

q) While crossing the floors, un-armoured cables shall be protected in conduits upto a height of 500 mm from floor level if not laid in tray.

v) Cable terminations and connections

- a) The termination and connection of cables shall be done strictly in accordance with cable termination kit manufacturer instructions, drawings etc. Cable jointer shall be qualified to carryout satisfactory cable jointing/ termination.
- b) Work shall include all clamps, fittings etc. and clamping, fitting, fixing, plumbing, soldering, drilling, cutting, taping, preparation of cable end, crimping of lug, insulated sleeving over control cable lugs, heat shrinking (where applicable), connecting to cable terminal, shorting and grounding as required to complete the job.
- c) The equipment will be generally provided with undrilled gland plates for cables/ conduit entry. The Contractor shall be responsible for punching of gland plates, painting and touching up. Holes shall not be made by gas cutting. The holes shall be true in shape. All cable entry points shall be sealed and made vermin and dust proof. Unused openings shall be effectively sealed by 2mm thick aluminium sheets.
- d) Control cable cores entering control panel/ switchgear/ MCCs etc. shall be neatly bunched, clamped and tied with self locking type nylon cable ties with de interlocking facility to keep them in position.
- e) The panels where a larger number of cables are to be terminated and cable identification may be difficult, each core ferrule shall include the complete cable number as per the drawings. The ferrules shall be indelible interlocking type and shall fit tightly on cores. Spare cores shall have similarly ferrules with a suffix letter 'S' alongwith cable numbers and coiled up after end sealing.
- f) All cable terminations shall be appropriately tightened to ensure secure and reliable connections.

5.11.5 Earthing system

- i) Earthing system shall be in strict accordance with IS:3043 and Indian Electricity Rules/ Acts.

Earthing system will be designed considering suitable corrosion allowance based on earthing conductor material and type of soil, for a service life of at least forty (40) years for maximum fault current or system fault current of 40kA whichever is higher for 1 second. The minimum rate of corrosion of earthing conductor shall be considered as 0.12mm per year while determining the conductor size.

- ii) The earth conductors shall be free from pitting, laminations, rust, scale and other electrical, mechanical defects.



- iii) The material of the earthing conductors shall be as follows :
- a) Conductors above ground level and in built up trenches - Galvanized steel
 - b) Conductors buried in earth - Mild steel
 - c) Earth electrodes - Mild steel rod
- iv) The sizes of earthing conductors for various electrical equipments shall be as below:

<u>Equipment</u>	<u>Earth conductor buried in earth</u>	<u>Earth conductor and in built-up trenches</u>
a) Main earth grid	40 mm Ø MS rod	65x12mm GS flat
b) 11kV switchgear/ equipment		65X12MM GS flat
c) 3.3 kV switchgear/ 415V switchgear/ Transformers		50X6MM GS flat
d) 415V Motors		
- above 125 kW		50 x 6mm GS flat
- 25 kW to 125 kW		25 x 6mm GS flat
- 1kW to 25 kW		25 x 3mm GS flat
e) Control panel/ desk		25 x 3 mm GS flat
f) Push button station/ Junction Box		8 SWG GI wire
g) Columns, structures, cable trays and bus ducts enclosures		50x6mm GS flat
h) Crane, rails, rail tracks and other non-current carrying metal parts		25x6mm GS flat

- v) Metallic frame of all electrical equipment shall be earthed by two separate and distinct connections to earthing system, each of 100% capacity, Crane rails, tracks, metal pipes and conduits shall also be effectively earthed at two points. Steel RCC columns, metallic stairs, and rails etc. of the building housing electrical equipment shall be connected to the nearby earthing grid conductor by one earthing ensured by bonding the different sections of hand rails and metallic stairs. Metallic sheaths/screens, and armour of multi-core cables shall be earthed at both ends. Metallic Sheaths and armour of single core cables shall be earthed at switchgear end only. Every alternate post of the switchyard fence shall be connected to earthing grid by one GS flat and gates by flexible lead to the earthed post. Railway tracks within the plant area shall be bonded across fish plates and connected to earthing grid at several locations. Portable tools, appliances and welding equipment shall be earthed by flexible insulated cable.
- vi) Each continuous laid lengths of cable tray shall be earthed at minimum two places by GS flats to earthing system, the distance between earthing points shall not exceed 30 metre. Wherever earth mat is not available Contractor shall do the necessary connections by driving an earth electrode in the ground.



- vii) Neutral connections and metallic conduits/ pipes shall not be used for the equipment earthing. Lightning protection system down conductors shall not be connected to other earthing conductors above the ground level.
- viii) Connections between earth leads and equipment shall normally be of bolted type. Contact surfaces shall be thoroughly cleaned before connections. Equipment bolted connections after being tested and checked shall be painted with anti corrosive paint/compound.
- ix) Suitable earth risers shall be provided above finished floor/ ground level, if the equipment is not available at the time of laying of main earth conductor.
- x) Connections between equipment earthing leads and between main earthing conductors shall be of welded type. For rust protection the welds should be treated with red lead compound and afterwards thickly coated with bitumen compound. All welded connections shall be made by electric arc welding.
- xi) Resistance of the joint shall not be more than the resistance of the equivalent length of conductors.
- xii) Earthing conductors along their run on columns, walls, etc. shall be supported by suitable welding/ cleating at interval of 1000mm and 750mm respectively.
- xiii) Earth pit shall be constructed as per IS:3043. Electrodes shall be embedded below permanent moisture level. Minimum spacing between electrodes shall be 600mm. Earth pits shall be treated with salt and charcoal if average resistance of soil is more than 20 ohm metre.
- xiv) Earthing conductor shall be buried at least 2000mm outside the fence of electrical installations. Every alternate post of the fences and all gates shall be connected to earthing grid by one lead.

5.11.6 Lightning Protection System

- i) All lightning protection installation work shall be in accordance with the Indian Electricity Rules and IS Code of Practice for the Protection of Buildings and allied Structures against Lightning (IS : 2309).
- ii) Lightning protection system shall comprise vertical air terminations, horizontal air terminations, down conductors, test links and earth electrodes.
- iii) Air terminations, down conductors and test links shall be of galvanized steel conductors and earth connection below ground level shall be of mild steel rod.
- iv) For tall buildings and structures, early streamer emission (ESE) type air terminal systems such as marketed by Heary Brothers (USA) are preferred.



- v) Lightning protection conductors/ air termination rods and circumferential bands provided at the top portion of chimney stack shall be lead coated in order to avoid melting by exposure to hot flue gases.
- vi) Horizontal air termination flats provided on top of boilers, main plant building, pump houses and other buildings shall be laid such that no part of the roof shall be more than 9 meters
- vii) Conductors of lightning protection system shall not be connected with conductors of earthing system above ground level.
- viii) Down conductors shall be cleated on outer side of building wall at 1000 mm interval or tack welded to outside of building columns at 1000 mm interval.
- ix) Down conductors shall be connected to separate earth electrodes through test points located at height of above 1000 mm above ground level. These earth electrodes shall in turn be connected to earth mat at two points.
- x) Lightning protection conductors shall not pass through or run inside GI conduits.
- xi) All metallic equipments on roof and exposed steel works within the vicinity of 2000 mm from lightning protection conductors in air shall be bonded to conductors of lightning protection system.
- xii) Lightning protection system shall have as few joints as possible and avoid sharp bends. Down conductors shall have, as far as possible, no joint except at test point and end termination.
- xiii) Termination at the metallic equipments on roof should be made by suitable nuts, bolts, pressure washers and bitumen washers with good electrical conductivity.
- xiv) All lightning protection conductors shall be exposed to atmosphere unless specifically mentioned.



5.12 DC STORAGE BATTERY

DC battery is required for certain essential unit auxiliaries, control supply for switchgear/control panels, emergency lighting etc. As such 2x100% sets of 220V of either Lead-Acid Plante or Nickel-Cadmium Battery banks catering to 100 percent unit and station load shall be provided for each unit.

5.12.1 Codes and Standards

All batteries shall be as per the following standards and codes:

(a) Lead –Acid Plante Battery

IS : 266	Specification for sulphuric acid
IS : 1069	Specification for water for storage batteries
IS : 1146	Specification for rubber and plastic containers for lead acid storage batteries
IS : 1652	Specification for stationary cells and batteries, lead acid type (with plant positive plates).
IS : 3116	Specification for sealing compound for lead acid batteries.
IS : 8320	General requirements and methods of tests for lead acid storage batteries
IS : 6071	Specification for synthetic separators for lead acid batteries

(b) Nickel-Cadmium Battery

IS : 10918	Specification for vented type Nickel Cadmium Batteries.
IS : 1069	Quality tolerances for water for storage batteries

5.12.2 Technical particulars

- i) The ampere-hour capacity of the DC storage battery shall be based on half an hour supply to the essential auxiliaries.
- ii) The permissible voltage variation for 220V battery shall be from 190V to 240V.
- iii) To cater to the electronic and microprocessor loads of the C&I system, suitable UPS/ Battery back-up system shall be provided.

iv) Battery Ratings

a) For Lead Acid Plante type Battery

- | | |
|--|---|
| - Battery Voltage | 220V |
| - Battery type | Stationary Lead Acid Plante high discharge type |
| - Capacity for ten(10) hour rate to 1.85V/ cell at 27 ⁰ C any time during the entire duty cycle | As per system requirement |



- Nominal discharge voltage/ cell 2.0V
- Float Voltage 2.2V/ Cell

- b) For Ni-Cd Type Battery
 - Battery Voltage 220V
 - Battery type Stationary Ni- Cadmium Pocket Plate High discharge type (KPH)
 - Capacity for five(5) hour rate to 1.14V/ Cell at 27⁰C any time during the entire duty cycle As per system requirement
 - Nominal discharge voltage/ cell 1.2V
 - Float voltage 1.42V/ Cell

- v) The unit auxiliaries for which emergency power supply from the DC storage battery is required are listed below:
 - Minimum emergency lighting system for reduced illumination during failure of main power supply.
 - Hydrogen seal-oil system.
 - TG bearing oil system (emergency lubricating oil pump)
 - Auxiliary control supply for 11kV unit and station switchgears and 3.3kV and 415V unit switchgears
 - Electrical protection system.
 - Turbine DC Jacking oil pumps (for main turbine and BFP turbine)
 - Any other emergency load considered necessary.

5.12.3 General Technical Requirements

5.12.3.1 Lead -Acid Plante Battery

i) Equipments

- a) DC Batteries shall be stationary lead acid Plante positive plate type conforming to IS:1652. The battery shall be high discharge performance type. For the purpose of design an ambient temperature of 50⁰C and relative humidity of 85% shall be considered.
- b) DC Batteries shall be suitable for standby duty. The Batteries shall normally be permanently connected to the load in parallel with a charger and shall supply the load during emergency conditions when AC supplies

are lost. Batteries shall be suitable for a long life under continuous float operations and occasional discharges. The batteries shall be boost charged at about 2.7 volts per cell maximum and float charged at about 2.2 V/cell.

ii) Construction Features

a) Containers

Containers shall be made of transparent glass, hard rubber, suitable robust, heat resistance, leak proof, non absorbent, acid resistant, non-bulging type and free from flaws, such as wrinkles, cracks, blisters, pin holes etc. Electrolyte level lines shall be marked on container in case of transparent containers. Float type level indicator shall be provided in case of opaque containers. The stem portion of the float should be long enough to prevent falling of the float inside the container even if there is no electrolyte in the container. The marking for the electrolyte level should be for the upper and lower limits. The material of level indicator shall be acid proof and oxidation proof. Container shall be closed/sealed lid type. Lid and sealing compound shall be non-cracking type. The container made of hard rubber and plastics shall be type tested as per IS:1146. All type tests shall be carried out for sealing compound as per IS:3116.

The pole sealing arrangement should be such that no acid particle get entrapped due to acid creep as a result of capillary action and it should be possible to remove and refix the sealing to carry out the maintenance.

b) Vent Plugs

Vent plugs shall be provided in each cells. They shall be anti-splash type, having more than one exit hole shall allow the gases to escape freely but shall prevent acid from coming out. The design shall be such that the water loss due to evaporation is kept to minimum. In addition the ventilator shall be easily removed for topping up the cells and of such dimensions that the syringe type hydrometer can be inserted into the vent to take electrolyte sample.

c) Plates

The plates shall be designed for maximum durability during all service conditions including high rate of discharge and rapid fluctuations of load. The construction of plates shall conform to latest revisions of IS: 1652 as applicable.

The separators shall maintain the electrical insulation between the plates and shall allow the electrolyte to flow freely. Separators should be suitable for continuous immersion in the electrolyte without distortion. The positive and negative post shall be clearly marked.



d) Sediment Space

Sufficient sediment space shall be provided so that cells will not have to be cleaned during normal life and prevent shorts within the cells.

f) Cell Insulator

Each cell shall be separately supported on PVC/ porcelain/ hard rubber insulators fixed on the racks with adequate clearance between adjacent cells. Minimum distance between adjacent cells shall be more than the buldge allowed for two cells in accordance with IS:1146.

g) Electrolyte

The electrolyte shall be prepared from battery grade sulphuric acid conforming to IS:266 and distilled water conforming to IS:1069. The cells shall be shipped dry uncharged. The electrolyte shall be supplied separately.

h) Connectors and fasteners

Lead or Lead coated copper connectors shall be used for connecting up adjacent cells and rows. Bolts, nuts and washers shall be effectively lead coated to prevent corrosion. The thickness of lead-coating of connectors should not be less than 0.025 mm. The lead coating thickness shall be measured in accordance with APPENDIX F of IS:6848 (latest edition). All the terminals and cells inter-connectors shall be fully insulated or have insulation shrouds. End take off connections from positive and negative poles of batteries shall be made by single core cables having stranded aluminium conductors and XLPE insulation. Necessary supports and lugs for termination of these cables on batteries shall also be supplied by the contractor. All connectors and lugs shall be capable of continuously carrying the 30 minutes discharge current of the respective Batteries and through fault short circuit current which the battery can produce and withstand for the period declared.

i) Battery racks

Wooden racks/ Steel Racks with anti-corrosive epoxy paint for all the batteries shall be provided. These racks shall be made of good quality first class seasoned teak. They shall be free standing type mounted on porcelain/ hard rubber/ PVC pads insulators. Batteries shall preferably be located in the single tier arrangement. However, batteries having a complete cell weight of lower than 50 Kg could be located in the double tier arrangement. The batteries rack and wooden support for cable termination shall be coated with three (3) coats of anti-acid paint of approved shade. Numbering tags, resistant to acid, for each cell shall be attached on to the necessary racks. The bottom tier of the stand shall not be less than 150 mm above the floor. Wherever racks are transported in

dismantled condition, suitable match markings shall be provided to facilitate easy assembly.

j) Manufacturer's Identification systems

The following information shall be indelibly marked on outside of each cell.

- Manufacturer's name and trade marks
- Country and year of manufacture.
- Manufacturer type designation.
- AH capacity at 10 hour discharge rate.
- Serial number

5.12.3.2 Nickel-Cadmium Battery

i) Equipments

- a) DC Batteries shall be stationary Nickel Cadmium Pocket plate type (KPH) conforming to IS:10918. The batteries shall be high discharge performance type as specified. For the purpose of design an ambient temperature of 50⁰C and relative humidity of 85% shall be considered.
- b) DC batteries shall be suitable for standby duty. The batteries shall normally be permanently connected to the load in parallel with a charger and shall supply the load during emergency conditions when AC supplies are lost. Batteries shall be suitable for a long life under continuous float operations and occasional discharges. The batteries shall be boost charged at about 1.54 to 1.7 volts per cell maximum and float charged at about 1.42 V/cell.

ii) Construction Features

a) Containers

Containers shall be made of polypropylene plastic material. Containers shall be robust, heat resistance, leak proof, non absorbent, alkali resistant, non-bulging type and free from flaws, such as wrinkles, cracks, blisters, pin holes etc. Electrolyte level lines shall be marked on container in case of translucent containers.

b) Vent Plugs

Vent plugs shall be provided in each cells. They shall be anti-splash type, having more than one exit hole shall allow the gases to escape freely but shall prevent alkali from coming out. The design shall be such that the water loss due to evaporation is kept to minimum. In addition the ventilator shall be easily removed for topping up the cells and of such dimensions that the syringe type hydrometer can be inserted into the vent to take electrolyte samples.



c) Plates

The plates shall be designed for maximum durability during all service conditions including high rate of discharge and rapid fluctuations of load. The construction of plates shall conform to latest revisions of IS:10918.

The separators shall maintain the electrical insulation between the plates and shall allow the electrolyte to flow freely. Separators should be suitable for continuous immersion in the electrolyte without distortion. The positive and negative terminal posts shall be clearly marked.

d) Sediment space

Sufficient sediment space shall be provided so that cells will not have to be cleaned during normal life and prevent shorts within the cells.

e) Cell Insulator

Each cell shall be separately supported on PVC/porcelain/hard rubber insulators fixed on to the racks with adequate clearance between adjacent cells. Minimum distance between the adjacent cells shall be more than the buldge allowed for two cells in accordance with IS:1146.

f) Electrolyte

The electrolyte shall be prepared from battery grade potassium hydroxide conforming to BS:1069.

The cells can be shipped either in charged condition or in dry condition

Necessary electrolyte for make-up shall be supplied separately.

g) Connectors and Fasteners

Nickel coated copper connectors shall be used for connecting up adjacent cells and rows. Bolts, nuts and washers shall be effectively Nickel coated to prevent corrosion. The thickness of Nickel coating of connectors should be not less than 0.02 mm. All the terminals and cells inter-connectors shall be fully insulated or have insulation shrouds. End take off connections from positive and negative poles of batteries shall be made by single core cables having stranded aluminium conductors and XLPE insulation. Necessary supports and lugs for termination of these cables on batteries shall also be supplied by the contractor. All connectors and lugs shall be capable of continuously carrying the 30 minutes discharge current of the respective batteries and through fault short circuit current which the battery can produce and withstand for the period declared. Contractor shall furnish necessary sizing calculations to prove compliance to the same. Suitable number of Inter-rack connectors

shall be supplied by the Bidder to suit the battery room layout during detailed engineering.

h) Battery racks

Mild steel racks for all the batteries shall be provided. They shall be free standing type mounted on porcelain/ hard rubber/ PVC pads insulators. Batteries shall preferably be located in the single tier arrangement. However, batteries having a complete cell weight of lower than 50 Kg could be located in the double tier arrangement. The batteries racks and supports for cable termination shall be coated with three (3) coats of anti-alkali paint of approved shade. Name plates, resistant to alkali, for each cell shall be attached on to the necessary racks. The bottom tier of the stand shall not be less than 150 mm above the floor.

Wherever racks are transported in dismantled conditions, match markings shall be provided to facilitate easy assembly.

i) Manufacturer's Identification system

The following information shall be indelibly marked on outside of each cell.

- Manufacturers' name and trade marks
- Country and year of manufacture.
- Manufacturer type designation.
- AH capacity at 5 hour discharge rate.
- Serial number



5.13 BATTERY CHARGER

2x100% float cum boost charger shall be provided for each unit battery bank as described in clause no. 5.12. In addition one no. spare float cum boost charger shall also be provided for each unit battery bank.

5.13.1 Codes and Standards

Battery chargers shall be as per the following standards and codes :

ANSI-C 37.90a	Guide for surge withstand capability tests
IS:5	Colours for ready mix paints.
IS : 694	PVC Insulated Cable for working voltages upto and including 1100V
IS : 1248	Specification for Direct acting indicating analogue electrical measuring instruments.
IS:13947 Pt-1	Degree of protection provided by enclosures for low voltage switch gear and control gear.
IS : 13947	Specification for low voltage switch gear and control gear
IS : 3231	Electrical relays for power system protection.
IS : 3842	Application guide for Electrical relays for AC System
IS : 3895	Mono-crystalline semi-conductor Rectifier Cells and Stacks
IS : 4540	Mono crystalline semi-conductor Rectifier assemblies and equipment.
IS:6005	Code of practice for phosphating of Iron and Steel
IS:6619	Safety Code for Semi-conductor Rectifier Equipment.
IS:6875	Control switches (switching devices for control and auxiliary circuits including contactor relays) for voltages upto 1000 VAC or 1200VDC
IS : 9000	Basic environmental testing procedures for electronic and electrical items.
IS:13703	Low voltage fuses for voltages not exceeding 1000 V AC, 1500VDC.
EEUA-45D	Performance requirements for electrical Alarm Annunciation system

5.13.2 Technical Particulars

- i) Battery Charger for Lead Acid Plante Type Battery :

The Batteries shall be Trickle charged at 2.15 to 2.25 Volts per cell. All chargers shall also be capable of Boost Charging the associated D.C. Battery at 2.0 to 2.7 Volts per cell at the desired rate. The Chargers shall be designed to operate, as mentioned above, at an ambient air temperature of 50°C.

- ii) Battery Charger for Nickel-Cadmium Type Battery :

The Batteries shall be Trickle charged at 1.4 to 1.42 Volts per cell. All chargers shall be capable of Boost Charging the associated D.C. Battery at 1.53 to 1.7 Volts per cell at the desired rate. The Chargers shall be designed to operate, as mentioned above, at an ambient air temperature of 50°C.

5.13.3 Interlocks - Necessary interlock shall also be provided to avoid accidental boost mode operation when loads are connected to the bus.

5.13.4 General Technical Particulars

5.13.4.1 Battery Charger for Lead Acid Plante Type Battery

- i) The Battery Chargers as well as their automatic regulators shall be of static type. Battery chargers shall be capable of continuous operation at the respective rated load in Trickle mode i.e. Trickle charging the associated DC lead-acid Batteries while supplying the DC loads.
- ii) Battery Chargers shall have a selector switch for selecting the battery charging mode i.e. whether Trickle or Boost charging.
- iii) All Battery Chargers shall be provided with facility for both automatic and manual control of output voltage and current. A selector switch shall be provided for selecting the mode of output voltage/current control, whether automatic or manual. Means shall be provided to avoid current/voltage surges of harmful magnitude/ nature which may arise during changeover from Auto to Manual mode or vice-versa under normal operating condition.
- iv) Soft start feature shall be provided to build up the voltage to the set value slowly within fifteen seconds. The chargers shall have load limiters which shall cause, when the voltage control is in automatic mode, a gradual lowering of the output voltage when the DC load current exceeds the load limiter setting of the Charger. The load limiter characteristic shall be such that any sustained overload or short circuit in DC system shall neither damage the Charger nor shall it cause blowing of any of the charger fuses. The Charger shall not trip on overload or external short circuit. After clearance of fault, the Charger voltage shall build up automatically when working in automatic mode.
- v) When on automatic control mode during Trickle charging, the Charger output voltage shall remain within $(\pm)1\%$ of the set value for AC input voltage variation of $(\pm) 10\%$, frequency variation of $(+)3/ (-)5\%$, a combined voltage and frequency variation of 10% (absolute sum) and a continuous DC load variation from zero to full load. Uniform and stepless adjustments of voltage setting (in both manual and automatic modes) shall be provided on the front of the Charger panel covering the entire Trickle charging output range specified. Stepless adjustment of the load limiter setting shall also be possible from 80% to 100% of the rated output current for Trickle charging mode.
- vi) During Boost charging, the Battery Chargers shall operate on constant current mode (When automatic regulator is in service). It shall be possible to adjust the Boost charging current continuously over a range of 50 to 100% of the rated output current for Boost charging mode. The charger output voltage shall automatically go on rising, when it is operating on boost mode, as the battery charges up. For limiting the

output voltage of the charger, a potentiometer shall be provided on the front of the panel, whereby it shall be possible to set the upper limit of this voltage anywhere in the output range specified for boost charging mode. All voltage and current setting potentiometers shall be vernier type.

- vii) Energising the Charger with fully charged battery connected plus 10% load shall not result in output voltage greater than 110% of the voltage setting. Time taken to stabilise, to within the specified limits as mentioned elsewhere, shall be less than fifteen seconds.
- viii) Momentary output voltage of the Charger, with the Battery connected shall be within 94% to 106% of the voltage setting during sudden load Change from 100% to 20% of full load or vice-versa. Output voltage shall return to, and remain, within the limits specified as mentioned elsewhere in less than 2 seconds after the above mentioned change.
- ix) The Charger manufacturer may offer an arrangement in which the voltage setting device for Trickle charging mode is also used as output voltage limit setting device for Boost charging mode, and the load limiter of the trickle charging mode is also used as Boost charging current setting device.
- x) Suitable filter circuits shall be provided in all the Chargers to limit the ripple content (peak to peak) in the output voltage to 1% irrespective of the DC load, even when they are not connected to a battery.
- xi) The DC System shall be ungrounded and float with respect to the ground potential when healthy. An earth fault relay shall be provided by the Employer in the DC distribution board for remote annunciation.

5.13.4.2 Battery Charger for Nickel-Cadmium Type Battery

- i) The Battery Chargers as well as their automatic regulators shall be of static type. Battery chargers shall be capable of continuous operation at the respective rated load in Trickle mode i.e. Trickle charging the associated DC Nickel-Cadmium Batteries while supplying the DC loads.
- ii) Battery Chargers shall have a selector switch for selecting the battery charging mode i.e. whether Trickle or Boost charging.
- iii) All Battery Chargers shall be provided with facility for both automatic and manual control of output voltage and current. A selector switch shall be provided for selecting the mode of output voltage/ current control, whether automatic or manual. Means shall be provided to avoid current/ voltage surges of harmful magnitude/ nature which may arise during changeover from Auto to Manual mode or vice-versa under normal operating condition.



- iv) Soft start features shall be provided to build up the voltage to the set value slowly within fifteen seconds. The chargers shall have load limiters which shall cause, when the voltage control is in automatic mode, a gradual lowering of the output voltage when the DC load current exceeds the load limiter setting of the charger. The load limiter characteristic shall be such that any sustained overload or short circuit in DC system shall not damage the charger, nor shall it cause blowing of any of the charger fuses. The charger shall not trip on overload or external short circuit. After clearance of fault, the charger voltage shall build up automatically when working in automatic mode.
- v) When on automatic control mode during Trickle charging, the Charger output voltage shall remain within (\pm)1% of the set value for AC input voltage variation of (\pm)10%, frequency variation of (+)3 to (-)5%, a combined voltage and frequency (absolute sum) variation of 10% and a continuous DC load variation from zero to full load. Uniform and stepless adjustments of voltage setting (in both manual and automatic modes) shall be provided on the front of the Charger panel covering the entire Trickle charging output range specified. Stepless adjustment of the load limiter setting shall also be possible from 80% to 100% of the rated output current for Trickle charging mode.
- vii) During Boost charging, the Battery Chargers shall operate on constant current mode (When automatic regulator is in service). It shall be possible to adjust the Boost charging current continuously over a range of 50 to 100% of the rated output current for Boost charging mode. The charger output voltage shall automatically go on rising, when it is operating on boost mode, as the battery charges up. For limiting the output voltage of the charger, a potentiometer shall be provided on the front of the panel, whereby it shall be possible to set the upper limit of this voltage anywhere in the output range specified for boost charging mode. All voltage and current setting potentiometers shall be vernier type.
- viii) Energising the Charger with fully charged battery connected plus 10% load shall not result in output voltage greater than 110% of the voltage setting. Time taken to stabilise, to within the specified limits as mentioned elsewhere shall be less than fifteen seconds.
- ix) Momentary output voltage of the Charger, with the Battery connected shall be within 94% to 106% of the voltage setting during sudden load Change from 100% to 20% of full load or vice-versa. Output voltage shall return to, and remain, within the limits specified as mentioned elsewhere in less than 2 seconds after the above mentioned change.
- x) The Charger manufacturer may offer an arrangement in which the voltage setting device for Trickle charging mode is also used as output voltage limit setting device for Boost charging mode, and the load limiter of the trickle charging mode is also used as Boost charging current setting device.



- xi) Suitable filter circuits shall be provided in all the Chargers to limit the ripple content (peak to peak) in the output voltage to 1% irrespective of the DC load, even when they are not connected to a battery.
- xii) The DC System shall be ungrounded and float with respect to the ground potential when healthy. An earth fault relay shall be provided by the Employer in the DC distribution board for remote annunciation.

5.13.4.3 Printed Circuits Boards (PCB)

PCB shall be made of glass epoxy of 1.6 mm thick, fire resistant, bonded with 99.8% pure copper foil, free of wrinkles, blisters, scratches and pinholes. The contact surface of the edge connectors of the PCBs shall be plated with hard gold to a minimum thickness of 5 microns. Component identification shall be printed on PCB by silk screen method. All PCBs shall be tropicalised and masked.

5.13.4.4 Contactors

All Battery Chargers shall have an AC contactor on the input side. It shall be of air break type and suitable for continuous duty. The operating coil shall be rated for 415 Volts AC.

5.13.4.5 Thermal Overload Relay

A thermal overload relay incorporating a distinct single phasing protection (using differential movement of bimetal strips) shall also be provided for the AC input. The relay shall trip the above contactor.

5.13.4.6 Rectifier-Transformers and Chokes

The rectifier transformer and chokes shall be dry and air cooled (AN) type. The rating of the rectifier-transformers and chokes shall correspond to the rating of the associated rectifier assembly. The rectifier-transformers and chokes shall have class-B insulation with temperature rise limited to class-A insulation value.

5.13.4.7 Rectifier Assembly

The rectifier assembly shall be full wave bridge type and designed to meet the duty as required by the respective Charger. The rectifier cells shall be provided with their own heat dissipation arrangement with natural air cooling. The rectifier shall utilise diodes/ thyristors and heat sinks rated to carry 200% of the load current continuously and the temperature of the heat sink shall not be permitted to exceed 85°C absolute duly considering the maximum charger panel inside temperature. The Contractor shall submit calculations to show what maximum junction temperature will be and what the heat sink temperature will be when operating at 200% and 100% load current continuously duly considering the maximum surrounding air temperature for these devices inside the charger panel assuming air ambient temperature of 50°C outside the panel. Necessary surge

protection devices and rectifier type fast acting fuses shall be provided in each arm of the rectifier connections.

5.13.4.8 Instruments

DC voltmeter, DC ammeter and AC voltmeter in 96 mm square shall be provided for all Chargers. The instruments shall be flush mounted type, dust proof and moisture resistant. The instruments shall have easily accessible means for zero adjustments. The instruments shall be of 1.5 accuracy class.

5.13.4.9 Air Break Switches

All Chargers shall have AC input and DC output switches of air break, single throw, load break and fault make type. The contacts of the switches shall open and close with a snap action. Switches shall be rated for 120% of the maximum continuous load. 'ON' and 'OFF' position of the switch shall be clearly indicated.

5.13.4.10 Control and Selector Switches

Control and selector switches shall be of rotary stay-put type with escutcheon plates showing the functions and positions. The switches shall be of sturdy construction and suitable for mounting on panel front. Switches with shrouding of live parts and sealing of contacts against dust ingress shall be preferred. The contact ratings shall be atleast the following :

- Make and carry continuously – 10 Amps.
- Breaking current at 220 V DC – 0.5 Amp. (inductive)
- Breaking current at 240 V AC – 5 Amp. At 0.3 p.f.

5.13.4.11 Fuses

Fuses shall be of HRC cartridge fuse link type. Fuses shall be mounted on fuse carriers which are mounted on fuse bases. Wherever it is not possible to mount fuses on fuse carriers, fuses shall be directly mounted on plug in type bases. In such cases one insulated fuse pulling handle shall be supplied for each charger. Kick-off fuses (trip fuses) with alarm contacts shall be provided for all DC fuses.

5.13.4.12 Indicating Lamps

Three (3) indicating lamps shall be provided to indicate AC supply availability. The indicating lamp shall be of panel mounting, filament type low wattage or LEDs and capable of clear status indication under the normal room illumination. The lamps shall be provided with series resistors (non-hygroscopic) preferably built in the lamp assembly and replaceable from front. The lamp covers shall be preferably screwed type, unbreakable and moulded from heat resistant material



5.13.4.13 Blocking Diode

Blocking diode shall be provided in the output circuit of each Charger to prevent current flow from the D.C. Battery into the Charger.

5.13.4.14 Annunciation System

Following annunciations shall be provided for local and remote indications in all chargers :

- a) AC supply failure
- b) Rectifier fuse failure
- c) Surge circuit fuse failure
- d) Filter fuse failure
- e) Load limiter operated
- f) Charger trip
- g) Battery on Boost
- h) Battery on Boost

5.13.4.15 Name Plates and Marking

The name plates shall be made of non-rusting metal/3 ply Lamicoid and shall have black back-ground with white engraved letters and secured by screws. These shall be provided near top edge on the front as well as on rear side of Charger. Name plates with full and clear inscriptions shall also be provided on and inside the panels for identification of the various equipments.

5.13.4.16 Construction

- i) The Chargers shall be indoor, floor mounted, self supporting sheet metal enclosed cubicle type. The Contractor shall supply all necessary base frames, anchor bolts and hardware. The Charger shall be fabricated using cold rolled sheet steel shall not less than 1.6 mm and shall have folded type of construction. The panel frame shall be fabricated using cold rolled sheet steel of thickness not less than 2.0 mm. Removable undrilled gland plates of at least 3.0 mm sheet steel and lugs for all cables shall be supplied by the Contractor. The lugs for cables shall be made of electrolytic copper with tin coat. Cable sizes shall be advised to the Contractor at a later date for provision of suitable lugs and gland plates. The Charger shall be tropicalised and vermin proof. Ventilation louvers shall be backed with fine brass wire mesh. All doors and covers shall be fitted with synthetic rubber gaskets. The Chargers shall have hinged



double leaf doors provided on front and/or backside for adequate access to the Charger internals. All the Charger cubicle doors shall be properly earthed. The degree of protection of Charger enclosure shall be atleast IP-42.

ii) All indicating instruments, control and selector switches and indicating lamps shall be mounted on the front side of the Charger. Design of panels shall be based on the following dimensions.

a)	Overall height	Maximum 2350 mm
b)	Operating handles (highest and lowest positions reached by operator's hands),	Maximum 1800 mm Minimum 350 mm
c)	Doors and panel handles and locks	Maximum 1800 mm Minimum 300 mm

iii) Electronic equipments shall be of modular design consisting of plug in modules in standard 19 inches metallic racks with metallic card guides. The cards should be provided with proper handles. Card to card wiring should be preferably through a mother board. Unplanned jumpering and track modifications are not permitted. Mechanical interlocks to prevent wrong insertion of cards should be provided. Each card shall have its junction and test points identified. Maintenance aids such as extension printed wiring boards and jumper leads shall be provided.

iv) The layout of Charger components shall be such that their heat losses do not give rise to excessive temperature within the Charger panel surface. Location of the electronic modules will be such that temperature rise of the location, in no case, will exceed 10°C over ambient air temperature outside the Charger.

v) Each Charger panel shall be provided with an illuminating lamp and one 5 Amp. Socket. Switches and fuses shall be provided separately for each of the above.

vi) Painting

Treatment as per IS:6005. Two coats of lead oxide primer followed by powder painting with final shade of RAL9002 for complete panel except end covers and RAL 5012 for end covers.



5.14 CONTROL, METERING AND PROTECTION

Following shall be included in the scope of the bidder:

- i) Complete control, operation and metering requirements for the following :
 - Generator, generator transformer, unit auxiliary transformers and associated circuit breakers
 - 11kV incomers, tie feeders and outgoing transformer, supply feeders of unit and station switchgears
 - 3.3kV incomers, bus-coupler feeders and outgoing transformer, supply feeders of unit switchgears and incomers of station switchgears
 - 415V incomers and bus-coupler feeders of unit and station switchgears
 - Diesel Generator sets
- ii) Protection and relay panels for generator, generator transformer and UATs including relay test kit

5.14.1 Codes and Standards

IEEE: Std. C37.111	Standard common format for transient data exchange (COMTRADE) for power systems
IEEE Std. C37.90.2	Standard for withstanding capability of relay systems to radiated electromagnetic interference from transceivers
ANSI/ IEEE C37.90	Relays and relay systems standard associated with electric power apparatus
ANSI/ IEEE C37.93	Power system protective relay applications of audio tones over telephone channels
IS: 3231	Electrical relays for power system protection
IS: 8686	Specification for static protective relays

5.14.2 Control Requirements

- i) Operators work station (OWS) along with thin film transistor (TFT) and keyboard etc. shall be located in unit control room and shall be provided for operation, control and interlocking of the following :
 - Generator, generator transformer, unit auxiliary transformers and associated circuit breakers
 - 11kV incomers, tie feeders and outgoing transformer, supply feeders of unit and station switchgears
 - 3.3kV incomers, bus-coupler feeders and outgoing transformer, supply feeders of unit switchgears and incomers of station switchgears
 - 415V incomers and bus-coupler feeders of unit and station switchgears
 - Diesel Generator sets



ii) General Technical Description

a) Generator

The generator and auxiliary systems shall be controlled from OWS located in unit control room through DDCMIS. All necessary control, interlock, indication, metering and annunciation shall be provided. These controls shall be in addition to local control panels for generator auxiliary systems.

The synchronization of the 400kV Generator transformer circuit breaker shall be performed through auto-synchronizer in DDCMIS. The manual synchronizing shall also be provided in the generator metering panel.

b) Auxiliary power distribution system

The control, monitoring, metering as required for the electrical auxiliary power distribution system comprising of 11kV, 3.3kV, 415V circuit breakers and unit auxiliary transformers, 11kV/3.3kV, 3.3kV/415V auxiliary service transformers within the power block including ESP switchgear shall be performed.

c) Diesel Generator set

The remote control of DG set shall be provided in addition to those provided in associated automatic mains failure (AMF) panels.

5.14.3 Metering

i) Generator

The ammeters, voltmeters, MW meter, MVAR meter, frequency meter, power-factor meter, energy meter (MWH) meter, MVARH meter, exciter field voltage and exciter field current meters including necessary transducers shall be provided in the generator metering panel located in unit control room.

The energy meters mentioned above shall be used for energy accounting and audit purposes and shall be located at a point after the generator stator terminals and before the tap-off to UATs and shall comply with the requirements of CEA regulations on Metering.

The digital indication for the above meters shall also be provided.

ii) 11kV, 3.3kV incomers, tie feeders and outgoing transformer, outgoing supply feeders.

The digital indication of Ammeter, kW meter and kWh meter located on the respective switchgears and bus voltages shall be provided.



- iii) 415V Incomer and bus-coupler feeders and Diesel Generator sets

The digital indication of Ammeter, kW meter and kWh meter located on the respective switchgears and bus voltages shall be provided.

5.14.4 Protection and Relay Panels

5.14.4.1 General requirements

i) Panels

- a) The panels shall be free standing, floor mounting type and completely metal enclosed. Cable entries shall be from bottom.
- b) The panels shall have removable gland plates with glands made of brass and suitable for armoured cables
- c) All equipment mounted on front and rear side of the panels shall have individual name plates with equipment designation engraved. Each panel shall also have circuit/ feeder designation name plate.
- d) Each panel shall be provided with a 240V AC fluorescent lighting fixture controlled by door switch as well as a 5A, 240V AC switch-socket unit.
- e) Voltage circuits for protection and metering shall be protected by fuses. Suitable fuse failure relays shall be provided to give an alarm for voltage circuits of protection/metering. Voltage selection scheme based on relays shall be provided for meters wherever possible.
- f) The DC supplies at the individual relay and protection panels shall be monitored by suitable relays and failure of DC supplies shall be annunciated.

ii) Relays

- a) The protective relays shall be numerical type. All relays, auxiliary relays and devices shall be of reputed make and types proven for the application and shall be subject to purchaser approval. The relays and timers shall have appropriate setting ranges, accuracy, resetting ratio, transient over-reach and other characteristics to provide required sensitivity to the satisfaction of the owner.
- b) Relays shall be suitable for efficient and reliable operation of the protection scheme. Necessary auxiliary relays, timers, trip relays, etc. required for complete scheme, interlocking, alarm, logging, etc. shall be provided. No control relay, which shall trip the circuit breaker when relay is de-energized, shall be employed in the circuits.



- c) Relays shall be flush mounted on the front with connections at the rear shall be draw-out or plug-in type/ modular case with proper testing facilities. Provision shall be made for easy isolation of trip circuits for testing and maintenance.
- d) Relays shall be provided with self reset contacts except the trip, lockout relays and interlocking (contact multiplication) relays which shall be manual reset type
- e) Auxiliary relays shall be provided in the trip circuits of protections located outside the board, such as buchholz relay, temperature indicators, fire protection, etc.
- f) Suitable measures shall be provided to ensure that transients present in CT and VT connections due to extraneous sources in 400kV system do not cause damage to static circuit.
- g) Only DC/ DC converters shall be provided in the relays, wherever necessary to provide a stable auxiliary supply for relay operation
- h) All relays shall have hand-reset flags or other means for ready visual indication of their operation and also of the faulty phase.
- i) The numerical relays shall have continuous self-monitoring and cyclical test facilities. The internal clock of the system shall be synchronized through the GPS Time Synchronizing System.
- j) Each numerical relay shall have a serial interface on the front for local communication to a PC and Printer. Facilities shall be provided to access each discrete protection function including modification in relay settings and monitoring of the relay from a HMI or a separate protection. The printout of all settings, scheme logic, event records etc. shall be accessible through the HMI. The display of various measured parameters during normal as well as fault conditions on a segregated phase basis shall be provided. LEDs and a backlit LCD screen shall be provided for visual indication and display of messages related to major trips/ alarms. Necessary multilevel password protection shall be provided.
- k) The sampling rate of analog inputs, the processing speed and processing cycle of digital values shall be selected to achieve the operating times of various protection functions specified. In case all protection functions specified do not have as a part of the standard numerical relay, separate discrete numerical relays can be provided.
- l) The numerical relays shall be provided with built-in disturbance recording facility. The output shall be available in IEEE/ COMTRADE format and shall be compatible with the dynamic relay test kit.



- m) The manufacturer of the numerical protection system shall carry out the complete engineering, testing and commissioning on site of the protection equipment including the associated relays and protection panels. The testing and commissioning protocols for the numerical protection systems offered shall be approved by the purchaser before commissioning on site.
- n) The numerical relays offered shall have self-diagnostic features to reduce the down time of the relay and to provide useful diagnostic information upon detection of an internal fault so as to speed up the maintenance. The necessary support documentation explaining in detail the self-diagnostic features of the numerical relays shall be furnished for the purchaser's use.

5.14.4.2 Protection

- 1) Protection Philosophy
 - The protection and control equipment and circuitry, shall be provided with two independent channels with reliable protection systems with separate DC supplies, separate CT/ VT cores and separate cables and hand-reset trip relays to obtain 100% reliability. The DC supplies to these protections shall be monitored.
 - Associated trip relays of the two systems shall be separate having sufficient number of contacts for all the functions.
 - Each protection system shall energize both trip coils of the circuit breaker.
 - The total critical fault clearance time from fault initiation in any part of the system shall be 80ms for phase to phase fault in the generator-transformer unit and for phase to phase and phase to earth faults in the 400kV system inter-connection.
 - Protective relay system shall be provided to protect the Electrical equipments from faults, overloading and abnormal operating conditions.
- 2) Each generator, generator transformer and unit auxiliary transformer etc. shall be provided with microprocessor based protection system comprising of the following protections :
 - i) Generator
 - a) Differential current protection (87)
 - b) Inter-turn fault protection (where split winding in stator is provided) if six neutral terminals are available (87TG)



- c) 100% stator earth fault protection (64G)
- d) Loss of field protection (40) (to be duplicated)
- e) Back-up impedance protection (21)
- f) Negative sequence current protection (46)
- g) Reverse power protection (32) (preferably of 3-phase power relay)
- h) Low forward power interlock (37) (preferably of 3-ph. power relay)
- i) Rotor earth fault Protection:
 - First stage (alarm) (64F1)
 - Second stage (trip) (64F2)
- j) Over voltage protection (59)
- k) Generator pole slipping protection (98)
- l) Synchro-check relay (25)
- m) Under-frequency protection (based on manufacturer's recommendations, under-frequency relays with timers set at prescribed values connected to alarm and trip (81).
- n) Stand by stator earth protection (64G2)
- o) Overload (51)
- p) Overheating (windings and/ or bearings) (49)(annunciation only)
- q) Over fluxing protection in addition to all aforecited protections (99) (to be duplicated)
- r) Accidental back energisation protection
- s) Voltage balance scheme for blocking voltage dependent protection, in case of VT-fuse failure (60)

In case digital multifunctional generator protection system (MGPS) is provided, the protections shall be duplicated. Each MGPS shall be preferably provided with individual inputs from CTs and VTs and connected to the independent set of hand-reset trip relays, such that one set is always available in case of testing and mal-operation of other set. Any protection, which is not a part of MGPS, separate discrete protection shall be provided as per the above table. The MGPS shall preferably have continuous self-monitoring and testing facilities.



- ii) Generator Transformer
 - a) Overall differential current protection covering the Generator zone also (87OA)
 - b) Time graded IDMT type back up non-directional over current protection in all phases on HV side (51)
 - c) Restricted earth fault protection (87NT)
 - d) Over- fluxing protection (99) (to be duplicated)
 - e) Neutral over-current protection against sustained external system earth faults (51 NT)
 - f) Buchholz protection (annunciation and trip) (63)
 - g) Winding temperature high for annunciation and trip (49T)
 - h) Oil temperature high (annunciation and trip) (49Q)
 - i) Pressure relief valve trip (PRV)
 - j) Generator Transformer differential protection for single phase bank (87T)
 - k) Overhead line connection differential protection(87L) (For 3 single phase banks, if 87L includes HV winding, separate 87NT is not mandatory)
 - l) Pole discrepancy protection of the breaker if single pole breakers are used (162)
 - m) Breaker (HV) back-up protection (protection against breaker failure) (50Z)
- iii) Unit Auxiliary Transformer
 - a) Differential current protection (87)
 - b) Restricted earth fault protection for LV winding in case of low resistance grounding (87N)
 - c) Back-up over- current protection on primary side (51)
 - d) Back-up earth fault protection for low/ high resistance grounding (LV side)

- e) Winding temperature high (annunciation and trip LV side breaker) (49T)
- f) Oil temperature high (annunciation and trip the LV side breaker) (49Q)
- g) Buchholz protection (annunciation and trip) (63)
- h) Pressure relief valve trip (PRV)

5.14.5 Generator Disturbance Recorder (DR)

- a. One no. microprocessor based Disturbance Recorder (DR) shall be provided for each generator to record graphic form of instantaneous values of voltage and current in all three phases and neutral, open and closed positions of relay contacts and breaker during disturbances.
- b. It shall have the facility for slow and fast scan to record transient and dynamic performance of the system.
- c. Both slow and fast scan facility shall have atleast 8 analog and 16 digital inputs.
- d. The slow scan facility shall be provide with the following minimum features
 - The input shall be MW, MVAR, field voltage, frequency and generator terminal voltage etc. Any transducers, if required for interfacing, shall be provided.
 - It shall be suitable to record the frequency excursions and response of generator field and governor control on system fluctuations.
 - It shall have options to select the scan rate in the range having a min. of 10Hz suitable to facilitate capture of low frequency waveforms in the range of 0.5 - 3Hz.
 - The non-volatile memory shall be suitable for recording for a minimum of 15 minute at scan rate corresponding to selected pre-fault zone of recording.
- e. The fast scan facility shall be provide with the following minimum features
 - The input shall be voltages and current etc. Any transducers, if required for interfacing, shall be provided.
 - It shall have scan rate of 1000Hz or better for sampling each of the analog channel having fundamental frequency of 50Hz. The frequency response for these channels shall be DC on the lower side to 500Hz or better on the upper side. Any interposing devices provided shall be suitable for this frequency response.



- The pre and post fault recording time shall be atleast 200 ms and 5s respectively.
- f. All external and internal faults in the DR equipment such as power supply fail, printer faults, paper exhausting, processor failure, memory failure etc. are to be indicated by means of light emitting diodes on the front of the panel of restitution unit. The DR shall be provided with a MMI (man machine interface) through a PC with VDU, keyboard and printer.
- g. The internal clock of the system shall be synchronized through the GPS. The output shall be in IEEE/ COMTRADE format. The format shall be compatible for dynamic protection Relay Test Kit Necessary interfacing and software for analysis shall also be provided.
- h. The amplitude resolution of the analog channels shall not be less than 16 bit and event resolution for digital channels shall be 1ms or better.

5.14.6 Electrical Control Board :

- a. One no. 'Electrical Control Board' (ECB) shall also be provided in the Central Control Room with minimum control and indication facilities for various equipments described below, as a back-up to Operator Work Station/ CRT keyboard (OWS) for both units and station supply. ECB shall be Simplex panel in mosaic grid configuration.
- b. Semaphore indicators shall be provided for isolators, earth-switches of 400kV system associated with generators. Further, control and indication of the important but not limited to the followings breakers shall also be provided:
 - i. Generator Transformer breaker (at 400kV), field breaker for both units including manual synchronizing facilities, governor and excitation control.
 - ii. Incoming and Tie breakers of 11kV, 3.3kV and 415V Unit Switchgears including Unit Emergency Switchgears of both units.
 - iii. Incoming and Tie breakers of 11kV, 3.3kV and 415V Station Switchgears.
 - iv. Emergency Diesel Generator sets
- c. Relevant Mimic shall be provided to cover the above 400kV, 11kV, 3.3kV and 415V system. Mimic shall be atleast 3 mm thick and 10 mm width and colour coded.
- d. The analogue meters for the following shall also be provided on ECB:
 - i. Generator current, voltage, MW, MVAR, power-factor, frequency, field current, field voltage, etc.
 - ii. Bus voltages for 400kV, 11kV, 3.3kV and 415V system



- iii. Incoming current and wattage
- iv. Emergency Diesel Generator set parameters
- v. DC system voltages
- e. Annunciation system with sufficient no. of window facia shall also be provided. Annunciation system shall be solid state type. Minimum 20% annunciation channels and window facia shall be provided as spare.
- f. Suitable arrangement shall be provided for the auto, manual synchronization consisting of synchroscope, voltmeters, frequency meters, lamps/ LED's, check synchronizing relays etc. for generators and other breakers where ever necessary.
- g. Necessary control switches, selector switches, lamps/ LED's, push buttons, auxiliary relays etc. shall be provided for completeness of the schemes.
- h. Suitable engraved/ painted name plates shall be provided for component identification.

5.14.7 Relay Test Kit for generator protection

Relay test kit shall comprise the following :

- i) One dynamic portable relay test system based on type Multi-Amp. PULSAR Cat. 10 E3T3N or equivalent with 3 current and 3 voltage modules allowing dynamic and steady state testing capabilities.
- ii) The DR recording of the generator in standard IEEE COMTRADE or EMTP simulations shall be compatible for transient testing of protections with this test system. Required software for steady state/ dynamic testing of the protection relays shall also be supplied.
- iii) Other auxiliary items like phantom loads, etc. shall also be supplied as required for protection relay testing.
- iv) One portable over-current relay testing equipment with a timing of 0-10 sec. Voltage rating shall be 200-250V and output current range shall be 0.05 to 200A.
- v) Test plugs for modular protections and two relay tool kits.



5.15 ELECTRICAL LABORATORY AND TESTING EQUIPMENT

The following minimum electrical laboratory and testing instruments shall be provided complete with necessary hardware and software and other accessories such as mains cables, calibration leads, clamps, connectors, operating manual, calibration certificate etc.

5.15.1 Auxiliary Power Supplies

The test equipments shall be suitable for working on the following auxiliary power supplies :

- i) 3 phase, 4 wire, 415V, 50Hz solidly earthed system with $\pm 10\%$ voltage variation, $\pm 5\%$ frequency variation and 10% combined voltage and frequency variation
- ii) 220V, 2 wire, DC system with floating neutral and (+)10% to (-)15% variation.

5.15.2 List of Minimum Requirements (for two units)

<u>Item No.</u>	<u>Description/Specification</u>	<u>Purpose</u>	<u>Quantity</u>
i)	Portable 5kV Digital Automatic Insulation Tester Complete with test leads, mains lead, carrying case, PC down load software, instruction manual, test/ calibration certificate etc. Measuring Ranges :	For checking the insulation level and polarising index of electrical equipments	Two (2)
a)	Resistance	: <100 kilo ohm - > 1 Terra ohm	
b)	Current	: <100 pico A - > 5 mA	
c)	Test Voltages	: 500, 1000, 2500 and 5000V	
d)	Accuracy	: Better than 2%	
e)	Test Time	: Adjustable <15 Sec. -> 10 minute	
f)	Display	: LCD 3½ digit with analog bargraph for Resistance, test voltage, current, PI	
g)	Data storage capacity	: >75 Values	
h)	Power Supply	: 240V, 50 Hz and rechargeable dc battery	



- i) MMI : Via RS232
- j) Printer/PC interface: Via RS232C
- k) Safety Standard : IEC 1010-1
- l) EMC Standard : EN50081-1 and EN 50082-1

- ii) **Portable HV Decade Resistance Box. In Polystyrene case with lid and carrying handle** For testing and calibration of insulation testers. One (1)
 - a) Overall range : 1 kilo ohms to 1 Terra ohms
 - b) Resolution : 1k Ohms
 - c) Accuracy : 0.1% - 2%
 - d) Connection : Shielded Plugs with 1 Metre cable

- iii) **Portable HV AC Test Set comprising** For checking the high voltage with-stand level of electrical equipments viz, transformers, switchgears, cables, motors/ generators etc. One (1)
 - a) An epoxy cast, single phase, 50-200kV/240V, 5kVA (continuous) and 10kVA (5minute) rated low discharge transformer with maximum discharge level of 1 PC mounted in a steel tank fitted with swivel cast or wheels, HV bushing.

A control unit with microprocessor based automatic control, programming key pad
 - b) LCD display analog ammeter and voltmeter with 2% accuracy trip push button, safety protections etc.

A zero interlock circuit shall be provided to prevent energization of HV output on less voltage control is set to zero.
 - c) Necessary power and metering cables, removable earth link fuses etc. shall be provided.

- iv) **Automatic Capacitance and Tan-Delta Test Set (Schering Bridge) with oil resistivity test cell.** For monitoring the condition of insulation of electrical equipments One (1)
Fully automatic, microprocessor-based, accurate ac voltage bridge.



- a) Input : 120/240V, 50 Hz
- b) Output : 0-12kV, 100 mA (Cont.), 200mA (15 min)
Extendible to 4A with resonating inductor
- c) Capacitance : 1.6 pF to 8 ∞ F (with 100pF std. capacitor)
- d) Measurement : with $\pm 0.02\%$ to $\pm 0.05\%$ accuracy and
0.0001 pF resolution
- e) Tan-delta : 1×10^{-6} to 9.999 with accuracy $\pm 0.5\%$ and
 1×10^{-6} resolution
- f) Capacitive current : 0-5A
- g) Measurement
oil test cell : 2.5 kV(RMS), 150°C, 100 cm³, 100 pF
- h) Display : Large graphic TFT (4-5 digit)
Test voltage, frequency, capacitance,
Tan-delta
- i) Interface : RS232 for Printer 1 PC
- v) **Portable Transformer Oil Breakdown Test Set** To test the dielectric strength of transformer oil. One (1)
Fully automatic, microprocessor.
Complete with transportation trolley oil test vessel with electrodes, PTFE agitator/lift-off sticks, gap-gauges, mains cable, operation manual calibration certificate, warranty certificate etc.
- a) Test Voltage : 0-100kV (RMS)
- b) Accuracy : $\pm 2\%$ of reading
- c) Switch-off response : < 4 mA
current.
- d) Switch-off response : < 6 mS
time
- e) Rate of rise of : 0.5/1/2/3/5KV per sec.
- f) Test voltage : Manual/Auto adjustable
- g) Display : Alpha numeric LCD



- h) Interface : RS 232, RS232C
- i) Standard : IEC 156, ASTM D877
ASTM D1816, BS 5874, IEC 1010-1
- vi) **Portable Karl-Fischer Test Set** To measure the One (1)
Coulometric test set for oils with specific percentage of moisture
gravity ranging from 0.6 to 1.4, with a contamination of
built-in printer transformer oil.
- a) Titration Method : Coulometric, Karl-Fischer
- b) Display : 40 character alpha numeric backlit LCD
- c) Sample Volume : 0.1, 0.2, 0.5, 1.0, 2.0, 5.0, 10.0 ml
- d) Sp. Gr. range : 0.6 to 1.4 in 0.01 steps
- e) Moisture range : 1 ppm – 100%
- f) Measuring range : 1 µg – 10 mg water
- g) End point detection : ac polarization
- h) End point indication : Visual display/ printout/ acoustic beep
- i) Titration speed : 2 mg/ minute maximum
- j) Maximum current : 400 mA
- k) Drift compensation : Automatically controlled
- l) Start delay : 10 seconds
- m) Stirrer speed : Microprocessor-controlled
- n) Accuracy : ± 3 µg to ±0.5%
- o) Calculation mode : Volume/ density or weight/ weight
- p) Printer : High Speed Thermal
- q) Power supply : 90-264V ac, 12V dc rechargeable battery

vii) 3-phase Portable Transformer Turns Ratio and Vector Group Meter One (1)

Fully automatic, microprocessor based having automatic tap changer control with internal chip card reader and built-in keyboard. In a robust mobile case having following features:

- a) Ratio Range : 0.75 to 10000
- b) Ratio accuracy : $\pm 0.1\%$ to $\pm 0.3\% \pm 1$ digit
- c) Measuring voltage : 63.5V to 240V
- d) Frequency range : 45-55 Hz
- e) Phase angle range : $\pm 90^0$
- f) Phase angle : $\pm 0.1^0 \pm 2$ digit accuracy
- g) Magnetising current : <1 mA - >500 mA
- h) Magnetising Current: Better than $\pm 2\%$ accuracy
- i) Measuring time : 5-20 seconds
- j) Data storage : > 200 sets of measurement
- k) Display : Backlit LCD 256 x 128 pixels
- l) Data displayed : Vector group, phase, tap position, ratio, Ratio deviation, phase angle, phase angle Deviation, mag. Current, pass-fail result
- m) Interface : RS232C, printer port
- n) Accessories : Windows compatible software for control Via PC

HV/LV cables, mains lead, clamps,
Operating Manual, guarantee certificate



- viii) Portable Digital DC Resistance Meter** For simultaneous measurement of HV and LV winding resistance and check on OLTC operation One (1)
- Dual channel, direct-reading ohm meter; having a safe discharge circuitry and in-built printer with date and time stamping, software for remote PC control heavy duty connecting cables, clamps, operating manual, test/ calibration certificate and transportable case.
- a) Measuring ranges
- | <u>Nominal Range</u> | <u>Resolution</u> |
|----------------------|-------------------|
| 0- 2 m Ohm | micro Ohm |
| 0- 20 m Ohm | 1.0 micro Ohm |
| 0- 200 m Ohm | 10 micro Ohm |
| 0- 2 Ohm | milli Ohm |
| 0-20 Ohm | milli Ohm |
| 0-200 Ohm | 10 milli Ohm |
- b) Accuracy : 0.1% of reading over entire range
- c) Exctn. Current : 0.1 – 25A with compliance open circuit voltage of 100V
- d) Display : 4½ digit backlit LCD
- e) Data Storage : Upto 700 measurements
- f) Interface for remote control : RS232
- ix) Portable High Current Digital Micro Ohm Meter** For measuring contact resistance of circuit breakers, isolators, busbars etc. One (1)
- Suitable for carrying out measurements in charged EHV (>400kV). Supplied with built-in charger, mains lead, operating manual, test/calibration certificate, mounted in a light weight portable case with clip-on clamps and voltage leads for 4-wire measurement system. Having following features :
- a) Measurement ranges :
- 0.01 – 100 micro ohm
- 0.1 – 600 micro ohm
- 1.0 – 6000 micro ohm



10.0 – 60000 micro ohm

0.1 – 600 m ohm

0.02 1.0 – 6000 m ohm

- b) Resolution : 0.01 micro ohm to 1.0 m Ohm
- c) Accuracy : (\pm) 0.2% --- (\pm) 0.5%
- d) Display : with 4 digit LED or LCD (backlit)
- e) Data Storage : > 300 readings
- f) Interface : RS232
- g) Test Current : Upto 200A

**x) Portable Primary and Secondary Current Injection Test Kit One (1)
with Separate Control and Loading Units**

- a) Control Unit
 - Current Output : 0-25A/0-50A (cont.)
0-50A/0-100A (upto 5 min)
 - Voltage Output : 0-230V
 - Current and Voltage measurement : By true RMS, 4 digit digital meters with \pm 0.6% accuracy (+6 digit)
 - Timing Units : For ON and OFF
 - Range : 0 – 1000 Sec.
 - Resolution : 1 m sec.
 - Accuracy : \pm 0.1% + 2 digits
 - Power supply : 230V \pm 10%, 45-551/2, 1-phase
 - Display : LCD/ LED
- b) Loading Unit
 - Ranges : 0-500A/0-1000A/0-2000A/0-3000A



-
- | | | | |
|-------------|--|--|---------|
| xi) | Portable Automatic Earth Tester

Microprocessor-controlled, user-friendly, with self-diagnostic features and alpha-numeric display, re-chargeable battery. Mounted in a robust case and provided with hammer and 4 GI spikes and 50M long cable on a cable winder. | For measuring earth electrode resistance and soil resistivity using Warner 4-terminal method. | One (1) |
| | a) Earth resistance range | : 0-20 k Ohms (Auto ranging) with 1 M Ω resolution and 60.5% 62 digit accuracy | |
| | b) Test frequency | : 100-160 Hz in 0.5 Hz steps | |
| | c) Test current | : 50 mA | |
| | d) Maxm output voltage: | <50V (RMS) | |
| | e) Maxm. Interference | : 40V peak to peak (50 Hz) | |
| | f) Display | : 3½ digit Alpha numeric LCD | |
| | g) Standards | : IEC 1010-1, EN 50081-1, EN 50082-1 | |
| xii) | Portable Three Phase Universal Protective Relay Test Set

Microprocessor-based user-friendly with digital signal processing.

Having large LCD display with programmable menu. Having programmable output current and voltage waveforms and phase angles. Having following additional features and specifications : | For testing various types of electro-mechanical, static and microprocessor based protective relays, MCCBs etc. | One (1) |
| | a) Input power | : 90-250V, 1 Ph, 50 Hz | |
| | b) Outputs | : One ac Current 0-100A
One ac Voltage 0-300V
One ac Voltage/Current, 0-240V/ 0-2.5A | |
| | c) Output frequency | : Selectable from 16.66 Hz – 300 Hz | |



- d) Output AC voltage : 0-360 deg. independently controlled phase shift
- e) Reading accuracy : $\pm 1\%$ for AC/DC Volts, Current
 ± 0.5 deg. In phase angle
 $\pm 0.02\%$ in power factor
 $\pm 1.5\%$ in active/reactive power
 $\pm 0.005\%$ in time
- f) Memory : Non volatile RAM
- g) Interface : RS port for PC and parallel printer port

xiii) Precision Digital Multimeter

One (1)

7½digit precision multi-meter for calibration of voltage/ current sources, decade resistance boxes, frequency sources with a large 24-digit vacuum fluorescent display, a bar-graph function allowing user programming of high and low pass/ fail limits, audible and visual indication of component specification and Auto Dynamic Filter (ADF) to enable automatic selection of suitable filter.

- a) Input Power : 110/220/240V AC 50 Hz
- b) DC Voltage Measurement Range : 3 MV to 10 kV with resolution of 10 nV and accuracy of ± 12 ppm + 6 digits
- c) DC Current Measurement Range : 3 μ A to 30A
Resolu. : 10 pA
Accu. : ± 75 ppm + 10 digits
- d) Resistance Measurement : 30 meg ohm to 1 G ohms
Resolu. : 10 n Ohm
Accu. : ± 200 ppm + 6 digits
- e) Frequency Measurement : 1 Hz to 100 K Hz
Resolu. : 1Hz
Accu. : ± 10 ppm + 1 digit
- f) AC Voltage Measurement : 3m V to 3 KV
Resolution : 100 nV
Accuracy : $\pm 0.05\%$ + 40 digits
- g) AC Current Measurement : 3 Micro Amp to 30A
Resolution : 100 pA
Accuracy : $\pm 0.1\%$ + 80 digits



- h) Capacitance Measurement : 0-300 Microfarad
Resolution : 1pF
Accuracy : $\pm 0.2\% + 20$ digits

Special Features : Self Test, Diode/ Zener Test, Maximum/ Minimum functions, continuity testing AC/ DC coupled facility count down and sample beep on long filter periods.

xiv) Portable Digital Frequency Meter One (1)

Rugged, high accuracy portable frequency meter/calibrator in a dust-tight, water resistant case. Having LCD display complete with test leads, carrying case, 9V battery and instruction manual.

- a) Ranges : 0-100 KHZ / 0-1000 Hz
b) Resolution : 1 KHZ / 0.1 Hz
c) Accuracy : $\pm 0.1\%$ FS ± 1 LSD
d) Step Size : 10% of range
e) Scroll Size : 0.1% of range
f) Input : 1V to 100V p-p
g) Output : 5V p-p Square Wave
h) Maxm. load : 5 mA

xv) Digital Sound Level Meter One (1)

Condenser type microphone, frequency and time weighting functions, AC and DC outputs supplied with 9V battery and calibration screw driver.

xvi) Digital Tachometer One (1)

Non-contact photo electric optical type. Having features such as reading hold, memory recall and low battery indication.

- a) Range : 10-100,000 RPM
b) Resolution : 0.1 RPM to 1 RPM
c) Accuracy : $\pm 0.1\%$ ± 1 digit to $\pm 0.15\%$ ± 1 digit
d) Display : 5 digit LCD
e) Optical Range : Upto minimum 300 mm



-
- xvii) Cable Fault Locator** One (1)
- Working on pulse reflection (echo) technique. Capable of discriminating between inter-core and core to earth fault with facility to detect high resistance faults (>10 ohms) complete with surge generator, acoustic receiver, input filters, head phones etc.
- a) Input : 240V, 1 phase, 50 Hz
- b) Range : 10 nano sec. To 2000 ns
- c) Impedance range : 25 ohms to 100 ohms
- d) Surge Generator : 15kV, 100 mA, <512 joules,
capacity 10-20 pulses per minute
- e) Display : Backlit LCD
- xviii) Portable Hand held SF₆ Gas Leakage Detector** One (1)
(wth audio-visual indication)
- Sensitivity : 3 to 5 ppm
- xix) Portable Hand held Hydrogen Gas Leakage Detector** One (1)
(wth audio-visual indication)
- Sensitivity : 50 to 100 ppm
- xx) Portable Vacuum Tester** One (1)
- For testing the condition of vacuum in medium voltage switchgear with automatic discharging facility and high voltage screened cable and over load/over voltage protection
- a) Display : Digital display of applied voltage in kV and leakage current in mA. Red and green indications for defective and acceptable chambers
- b) Resolution : 0.1 kV and 0.01 mA
- c) Input : 240V AC, 50 Hz
- d) Output : 0-60 kV DC Adjustable
0-9.99 mA Adjustable
- e) Loading time : Upto 30 seconds
-



xxi) Portable Light Intensity Meter One (1)

With selenium photocell, 2 metres lead and filters.

- a) Ranges : 0-15/30/100/300/1000/3000 lux
- b) Accuracy : $\pm 4\%$ of full scale

xxii) Portable Circuit Breaker Motion Analyser One (1)

For analyzing performance of SF6/Vacuum/air circuit breakers upto 400kV

Microprocessor-based capable of measuring, recording and printing opening/ closing times and velocity, coil currents, dynamic contact resistance of main/aux. and arcing contacts, pole discrepancy etc.

The instrument shall have user-friendly menu driven software for easy operation and reduced set up time. It shall have communication ports for downloading of data from memory on to a PC. It should have a built-in DC battery and printer. Other specifications shall be as follows :

- a) Input Supply : 110-240V, 50Hz with built-in DC battery backup with charger
- b) Current injection : upto 100A DC
- c) Timing Range : 0-9.99 S. with a resolution of 0.1mS and accuracy of $\pm 0.01\%$
- d) Number of channels : 12 analog, 24 digital
- e) Display : 16 character alphanumeric LCD

xxiii) Generator On-line Partial Discharge Real Time Monitoring System Two (2)

To detect and monitor partial discharge activity in generator stator windings and vibrations in generator end windings by acoustic sensors. To generate alarms in case of excessive partial discharge or end winding vibrations. Should have the capability to acquire partial discharge patterns and determine PD quantities as apparent charge, quadratic rate and average discharge current for each phase.

Standalone type with facility for storage of trend data and patterns. With facility to download patterns and trends on to PC or LAN; visualization software and automatic report generation. Having noise suppression circuitry for input and signal transfer.



The surge capacitors connected on the line Terminals of the generators shall be used as PD sensors. Necessary surge capacitor connection kit shall be included and the instrument shall be compatible with surge capacitors of 0.25 micro farads/ 24Kv supplied with the generators

The instrument shall be in 19" rack-mounted design. Housed in a wall-mounting IP65 case. Other specifications as below :

- a) PD Input : 4 channels, 0-30 V rms
- b) Frequency Ranges : 0.3 MHz - About 10 M Hz
- c) Acquisition Software : Standalone C-based
- d) Evaluation Software : Standalone Java based
- e) Data Storage : Upto 48 values per channel 1 Pattern per day
- f) Visualisation : Web server with standard web-browser and Windows based internet capable software
- g) Communication : 100 M Bit Ethernet interface with TCP/ IP protocol and fibre-optic communication.

xxiv) Interfacial Tension Meter for Transformer Oil One (1)

Motorised operation using a Platinum Iridium Ring. In dust tight IP55 enclosure

- a) Range : 0-90 Dynes/per cm.
- b) Zero Drift : < 0.1 Dynes/m in 24 Hours
- c) Resolution : 0.05 Dynes
- d) Accuracy : ± 0.5 Dynes/cm

xxv) Portable, Hand-held Thermal Imaging Camera One (1)

Having voice recording and alarm facility, double ocular view finder and clear CCD lens, multi-spot (Minimum 4) temperature measurement and High End image analysis software capable of generating wizard guided reports and trend analyses etc. Battery operated.



- a) Temperature Range : -10°C to 2000°C
- b) Detector Type : Uncooled Focal Plane Array
- c) Thermal Sensitivity : 0.08°C @ 30°C
- d) Frame Rate : 50 Hz
- e) Field of View : $20^{\circ} \times 20^{\circ}$
- f) Spectral Response : 8 to 14 microns
- g) Battery Operation : For atleast 2-hours

xxvi) Portable High Voltage/Live Line Detector Two (2)

Electronic type, giving audio-visual indication for presence of voltage/charge. Having in-built self-diagnostic check feature. Insulating stick shall be class 'F' insulated.

Range : Upto 300 kV

xxvii) Tong Testers

Digital clamp-on volt-ammeters

Ranges :

- a) 0-5/ 25A, 0-60/ 300/ 600V Three (3)
- b) 0-1/ 5A, 0-60/ 300/ 600V Three (3)
- c) 0-10/ 30/ 300/ 1000A, 0-60/ 300/ 600V Three (3)

xxviii) Portable Phase Sequence/Continuity Indicators Three (3)

To indicate phase continuity and phase rotation sequence of 3-phase power circuits. Complete with colour-coded and insulated 1 Metre long fused leads with boot-protected alligator clips and carrying case.

Having an impact resistant plastic body with encapsulated circuitry incorporating neon indicators for phase continuity and phase sequence.

Rated 100-600V, 40-60 Hz

xxix) Relay Tool Kit Two (2)

Comprising following minimum tools :

- a) Spring setting tool
- b) Inspection mirror and torch
- c) Ring spanners
- d) Box spanners



- e) Burnishing tool
- f) Contact pressure gauge
- g) Factor gauges
- h) Test plugs with link plugs
- i) Screw drivers
- j) Nose pliers
- k) Scissors

xxx) HV Discharge Rod and Portable Earthing Equipment Two (2)

Class 'F' insulated. Having non-linear carbon film resistor with negative temperature co-efficient. Non-hygroscopic

- a) Dimensions : ID 25 mm
OD 31 mm
Length 1250 mm (main rod and each extension)
Total Length : 6 metres
- b) Discharge hook: 100 mm dia
12.5 mm dia copper rod
- c) Earth lead : Flexible braided copper
- d) Voltage rating : Upto 400 kV

xxxi) Hot Sticks (Live/ Dead Line Tester) Two (2)

Class 'F' insulated, upto 400kV, extendible from 1.25 metre to 6.0 metres with inbuilt self-check feature. Contact or proximity type in a special carrying case.



5.16 EMERGENCY DIESEL GENERATING SETS

One number DG set complete with Automatic Mains Failure (AMF) panel and other accessories shall be provided for each unit. In addition, one number common stand-by DG set shall also be provided.

5.16.1 Codes and Standards

IS:10000, BS:5514 and as per standard practice of diesel engine manufacturer's association of USA	Diesel engine
IS : 4722 / IEC - 60034	Generator
IS : 3977	Diesel oil system

5.16.2 Design Requirements and Sizing Criteria

- a) AMF (Automatic Mains Failure) Diesel Generator Sets capable of starting and picking up the load within 30 seconds shall be provided for power supply to the following :
 - i) Barring gear motors of turbo-generator sets and BFP turbine
 - ii) Seal oil system comprising of (AC seal oil pump, Re-circulating seal oil pump and seal oil vacuum pump)
 - iii) Air pre-heaters lubricating oil pumps
 - iv) Jacking oil pumps for main turbine and for BFP turbine
 - v) Main oil tank vapour extractors
 - vi) Turbine gear oil pump.
 - vii) Turbine Auxiliary oil pump (AOP)
 - viii) Stator water cooling pumps.
 - ix) Bearing chamber exhaust fans for hydrogen.
 - x) Lubrication oil systems for BFP, ID, FD and PA fans.
 - xi) Seal air fans.
 - xii) Elevators.
 - xiii) Air pre-heaters lubricating oil pumps.
 - xiv) Battery chargers for 220 volts and other DC system



- xv) Emergency lighting for reduced illumination (This shall cover 20% of fixtures in the main plant building and switchyard control building).
 - xvi) 220 volts control supply.
 - xvii) Scanner air fans.
 - xviii) Emergency service cubicle.
 - xix) HP and LP bypass auxiliary PRDS oil supply motors.
 - xx) Instrumentation and data acquisition system.
 - xxi) Standby air conditioner for control room and control equipment room, if required.
 - xxii) Mill inching motor.
 - xxiii) Mill lube oil pumps.
 - xxiv) BFP oil tank vapour extractors.
 - xxv) DM make up pumps
 - xxvi) Condenser vacuum breaker valve.
 - xxvii) BFP vacuum breaker valve.
- b) The sizing of DG set shall be based on the actual loads thrown on DG sets after the emergency and not the algebraic sum of all connected loads. The minimum capacity of diesel generating set shall be 1250kVA for 500MW unit (or ...kVA for ...MW unit)⁸. There will be three (3) no. DG sets, one for each unit and one common standby.
- c) Wherever DG set is started with DC motor, separate automobile type battery with charger shall be provided for starting.

5.16.3 Installation

The generating set shall be installed indoor/ inside weather proof enclosure.

5.16.4 Critical speed

Critical speed of DG shall not be lesser than 120% of the normal speed.

⁸ To be indicated by purchaser as applicable



5.16.5 General Technical Requirements

i) Starting and Control

- a) The DG Set shall have integrated control with automatic starting sequence from the manually initiated command from a single push button. It shall also have auto initiation through a 'No volt relay' and Auto position of auto/manual selector switch. The DG set shall also issue automatic closing command to its breaker on achieving rated voltage and frequency on its terminals.
- b) The starting time required from the initiating signal until the operating speed and voltage is attained and the engine and generator are ready to take load, shall not be greater than 30 seconds. Three attempt starting facility shall be provided using two impulse timers and a summation timer. The DG shall be capable of being stopped manually from remote and local. Interlock shall be provided in DG control panel to prevent shutting down operation as long as the circuit breaker at its generator output is closed.
- c) If electrical self starting system is provided, the source of energy shall be batteries backed up by battery chargers.
- d) If compressed air starting is provided, 2x100% air compressors to meet the entire compressed air requirement of the diesel generating set with one number electric motor driven and another with diesel engine driven with manual cranking system shall be provided. Air receiver shall be provided with necessary piping, fitting and instrumentation.
- e) The starter motor shall conform to IS : 4722.
- f) Suitable thermal insulation together with jackets shall be provided on all exposed hot pipes and equipment to limit the surface temperature to 60⁰C.

ii) Battery and Battery charger

- a) The battery shall conform to the requirements of IS:7372. A suitable battery charger using semiconductor rectifier shall be provided to recharge the battery within 10 hours. The minimum voltage at the end of load cycle shall not be less than 1.75 volts/ cell.
- b) The battery or compressed air system for starting the engine shall be capable of performing six (6) normal starts without recharging or refilling. In any case, continuous cranking for at least one minute shall be possible.

5.16.6 Diesel Engine

i) Type

Stationary type, 4-stroke with Vertical in line or 'V' type cylinder arrangement and turbo charged and water cooled.

ii) Rating

a) Electrical output	As per design calculation for emergency duty application
b) Ambient temperature	50 ⁰ C
c) Relative Humidity	85%
d) Noise level at works at one metre distance from DG set	105 dB sound pressure
e) Noise level at ½ metre distance from DG acoustic enclosure	Room shall be acoustically treated for 25dB insertion loss
f) Fuel	All types of diesel fuel available in India
g) Maximum speed	1500 rpm
h) Duty	12 hours continuous running, of which one hour at 10% overload at rated speed
i) Governor	Electronic A1 type as per BS:5514
j) Vibrations	Maximum 250 microns peak to peak with anti-vibration pads
k) Starting	Electrical self starting or by compressed air
l) Fuel service tank	990 litres
m) Air intake system	Dry type air filter suitable for site conditions.
n) Cooling	Air cooled/ Forced water cooled.

iii) Constructional features

- a) Diesel engine shall be mounted on visco damper type vibration dampening system and shall be complete with integral air intake through dry type air filters and exhaust systems, metering facility, speed regulation system, fuel injection system, lube oil system, primary cooling water system along with necessary filters, silencers, ducts, piping and fittings, valves, instruments, etc.
- b) The generating unit shall be complete with all auxiliaries and its performance, torsional vibration, materials and workmanship, etc. shall be in accordance with the standard practices of diesel engine manufacturer's association in USA, IS-10000, BS-5514 or equivalent. The engine shall be properly balanced so as to transmit only small unbalanced forces to the foundation.



iv) Diesel oil system

- a) The diesel oil system as provided shall be complete with duplex type filters, hoses, piping, fittings, relief valves, supports, control and instrumentation and all other accessories to make it complete.
- b) The fuel consumption of the engine at full and three quarters of its rated power output shall be indicated.
- c) A day oil tank of 990 litres fuel capacity shall be provided, mounted on fabricated steel platform. The tank shall be complete with level indicator marked in litres, two nos. of level switches, filling inlet with removable screen, an outlet, a drain plug, an air vent and necessary piping. The fuel tank shall be painted with oil resistant paint. All pipe joints shall be brazed/ welded.

v) Lubricating oil system

- a) Automatic pressure lubrication shall be provided by a shaft driven gear type pump through an oil cooler and fine mesh filters to the end bearing, camshaft bearings, camshaft chain and gear drives, governor, air starting, distribution, auxiliary drive gears etc.
- b) If pre-lubrication is required before starting of the DG set, than one (1) no. electrically operated and one (1) no. standby DC operated lube oil pump shall also be provided for the purpose.
- c) All necessary accessories like pressure gauges, temperature and oil level indicators, pressure relief valves, bypass valves, pressure switches for alarm and control shall be furnished together with all inter connecting piping, fittings, supports, valves, etc.

vi) Cooling system

Totally air cooled type DG sets are preferable. However, in case jacket water cooling system is offered, the same shall be in closed cycle and have radiator located in front of the engine with a fan driven mechanically from the engine shaft. Forced water circulation by means of pump driven by the engine shaft shall be employed. As an alternative to radiator located in front of the engine with a fan driven mechanically from the engine shaft, separately located radiator (which will be located outside the DG room) with motor driven fan by 415V DG MCC directly fed from alternator terminals. The radiator tube shall be of copper with sufficient transfer area. Heat exchanger/ cooling tower arrangement shall also be acceptable.

vii) Governing system

- a) The governor shall be electronic A1 type as per BS-5514



- b) The governor shall have necessary characteristics to maintain the speed substantially constant even with sudden variation in load. However a tripping shall be provided even if speed exceeds the maximum permissible limit.
- c) A mechanical over-speed trip device shall be provided to automatically shut-off fuel in case the speed exceeds 110% of the rated value.

viii) Ancillary equipment - The following minimum equipments shall be provided :

- a) Flywheel
- b) Fuel piping
- c) Tachometer/RPM indicator
- d) Lubricating oil cooler (if applicable)
- e) Exhaust silencer and piping
- f) Fuel and lubricating oil filters, air filters.
- g) Temperature gauges for water and lubricating oil and pressure gauges for lubricating oil.
- h) Hand barring gear.
- i) Necessary foundation bolts and base channels for the engine, alternator, fuel service tank and for all other equipment included in this package.
- j) Base frames
- k) Platforms and hand railing and access ladder (if applicable)
- l) Starting equipment
- m) Protective equipment preferably in the form of fuel cut-off solenoid and suitable relays to protect the engine against low lubrication pressure.
- n) Lifting attachment for lifting the complete set or the engine alternator separately.
- o) Radiator/ Heat Exchanger.

5.16.7 Generator

- i) The generator shall be of totally enclosed or screen protected drip proof and self air cooled type. The generator shall be driven by the diesel engine specified above and shall match the same in all respects. The generator shall conform to IS-4722, IEC-60034.
- ii) AC generator shall be supplied along with excitation system, AVR and include all necessary auxiliaries.
- iii) The Generator shall be star connected, 3-phase, 50Hz synchronous generator and shall have a continuous rating. The operating conditions shall be as follows:
 - a) Voltage 415V
 - b) Frequency 50Hz (+3 to -5%)
 - c) Power factor 0.80



- iv) The generator stator and rotor windings core insulation and all connections including main and neutral leads shall have class-F or better insulation.
- v) Resistance element temperature detector shall be installed at the following locations :
 - a) 6 nos. duplex or 12 nos. simplex RTD's in stator windings.
 - b) 1 no. RTD element in each bearing.
- vi) Suitably rated 240V, single phase, 50Hz, space heaters located in lower part of alternator shall be provided to maintain the internal temperature above the dew point to prevent moisture condensation on the insulation when the set is not running.
- vii) Separate terminal boxes shall be provided for phase and neutral side of leads. The terminal boxes shall be dust proof, weather proof phase segregated double walled (metallic as well as insulated barriers) having degree of protection of IP-54 as per IS: 13947.
- viii) The terminal box shall be of sufficient size to conveniently terminate the size and number of cables. Suitable tinned copper pads shall be provided for power cable termination along with all necessary hardware and cable lugs. For single phase cables gland plate shall be of nonmagnetic material and shall be removable type. The necessary CT's for differential protection shall be provided on neutral side.
- ix) Alternator vibration level shall not exceed the values as defined in IS:12075. Alternators in case driven by diesel engine shall be able to withstand vibration level of 9 mm/sec. as per BS 5000 Part III,

5.16.8 Excitation system

The generator shall be provided with complete excitation system capable of supplying the excitation current of the generator under all conditions of output from no load to full load and capable of maintaining voltage of the generator constant at any value with (\pm)10% of the rated voltage. It shall be possible to set the same from remote also. The type of insulation of the armature field winding of the exciter shall be class-B and the temperature shall not exceed the values specified in IEC-60034 Part-I for different parts. The excitation system shall be of static excitation system/ brushless excitation system/ any other modern excitation system.

5.16.9 Automatic Voltage Regulator (AVR)

- i) The regulation system shall be provided with equipment for automatic and manual control. Necessary equipment shall be furnished for the following:
 - a) To prevent automatic rise of field voltage in case of failure of potential supply.
 - b) To initiate transfer from automatic to manual control of excitation on fuse failure in the generator potential signal.



- ii) The regulator shall regulate from generator current and potential signals.
- iii) The above equipment shall be housed in self standing sheet metal cubicle, and shall be completely tested and wired.
- iv) The regulation equipment shall function correctly between the frequencies 47.5Hz and 51.5Hz and shall ensure a voltage variation not more than (\pm) 1% of the set point in steady operating condition between no load to full load.

5.16.10 Protection

- a) Differential Protection (87) – Three Pole
- b) Reverse Power Protection.
- c) Overload Alarm on one phase
- d) Earth Fault Detection Relay (64)
- e) Voltage controlled over current relay
- f) Generator under/over voltage Protection
- g) Hand Reset/ Lockout Relay.

5.16.11 Metering - The following minimum meters shall be provided.

- a) 3 no. AC ammeters of suitable range.
- b) 1 no. AC Voltmeter of suitable range with selector switch.
- c) 1 no. Wattmeter
- d) 1 no. Watthour meter having accuracy of 1.0 class.
- e) 1 no. frequency meter
- f) 1 no. Power Factor meter.

5.16.12 Diesel Generator Control Panel

- i) One local control panel with provision for local starting shall be provided which shall incorporate all controls required for starting, monitoring, regulating and stopping DG set. It shall be equipped with all necessary instrumentation to provide adequate surveillance of DG set under all operating conditions including 'Standby'. The local control panel shall be of robust construction, floor mounting, free standing type made of 2.0 mm thick cold rolled sheet steel. Neoprene gaskets shall be provided between all openings and joints. The control panels shall have IP-52 degree of protection as per IS:13947 Part-I.
- ii) All cables shall have bottom entry. Separate cable chamber shall be provided in the control panel for all incoming and outgoing cables.
- iii) A tinned copper/ aluminium bar of adequate dimension shall be provided for earth connection complete with nuts and bolts as required for external connection to earth grid.
- iv) The final paint shade shall conform to shade grey RAL 9002. The identification tag shall be white in colour shade RAL 9010.



- v) CT shorting links, test terminal blocks etc. shall be provided. All the equipment mounted inside the control panel shall be identified by lamicoid labels/ stenciling by paint.
- vi) Panel shall be provided with panel illumination lamp operated by the door switch and thermostat-controlled space heater.
- vii) The manual control of the engine speed and generator voltage shall be provided through suitable Raise/ Lower control switches on the local control panel and remote.
- viii) The following tripping and alarms shall be provided:
 - Fail to start (Alarm)
 - Overload (Alarm)
 - Cooling water pressure low (Trip)
 - Lube oil pressure inadequate (Trip)
 - Over Speed (Trip)
 - High cooling water temperature (Trip)
 - Abnormal voltage (under and over voltage) (Alarm).
 - Charger ON/OFF (Alarm)
 - Fuel level low in day tank (Alarm and Trip)
 - High lube oil temperature (Trip)
 - Low air pressure in receiver (Alarm)
 - Alternator stator temperature high (Alarm)
 - Electrical protective relays operated (Trip)
- ix) Necessary pressure switches, level switches, thermostats, flow switches, auxiliary relays, etc. required for the above alarm and annunciation system shall be provided.
- x) The following minimum instruments shall be mounted on each engine:
 - Thermometers for lube oil temperature.
 - Pressure gauges for lube oil, fuel oil and air starting systems.
 - Differential pressure gauges across strainers and filters
 - Speed indicator
 - Exhaust pyrometers with temperature switch.
 - Level switches for alarm and trip in day fuel oil tank.

5.16.13 Sound proofing system

- i) The sound proofing system shall be designed to achieve a minimum 25dB insertion loss/ maximum sound level at ½ metre distance from enclosure/ acoustically treated room as per State Pollution Control Board norms. The ventilation system shall be of adequate design to ensure no deterioration in performance of DG.



- ii) The sound absorptive layer shall comprise of bonded type mineral wool/ glass wool of adequate thickness and density to comply the design requirements.
- iii) The exposed surface of lining inside room/ enclosure shall be retained in place by a adequately thick CRCA/ aluminium perforated sheet (not less than 0.8mm). Absorptive lining shall be provided between the perforated sheet and absorbing material. Necessary acoustic sealing shall be done in the panels/ modular unit joints.
- iv) All hardware of mild steel shall be electro-galvanised.
- v) The door design shall be generally compatible to the enclosure design/ acoustic treatment of room. The bonded mineral wool slab of adequate thickness shall be used. The door shall be provided with heavy duty hinges and handles. The sealing shall be done with neoprene/ silicon rubber gasket to avoid leakage of noise. The size of the door shall be as per the room design/ functional requirements.
- vi) Acoustic treatment of DG room shall be done. The following requirements shall be complied in case of acoustic treatment:
 - a) The acoustic treatment of wall, ceiling and other opening shall be done using galvanised steel sections. The framework shall be fixed on wall/ ceiling using expansion fasteners.
 - b) Bonded mineral wool slab of required density and thickness shall be used for sound absorptive layer. This shall be concealed with perforated aluminium/ CRCA sheet. Suitable lining shall be provided between the bonded wool and perforated sheet.
 - c) Necessary acoustic sealing shall be done in the panel joints.
 - d) In rolling shutter area, removable type of acoustic paneling shall be done to facilitate maintenance.
- vii) Ventilation system of adequate capacity shall be provided. The system shall comprise of tubular axial flow fans for air intake and air exhaust. The ventilation shall be design to ensure required air flow rate as per manufacturer recommendations, after providing necessary acoustic treatment/ silencers in air flow path. The ventilation system shall be design to prevent leakage of sound and maintain required room temperature for comfortable working in the area not to deteriorate performance of DG.
- viii) The construction of ventilation duct shall be similar to that of the enclosure/ room acoustic treatment
- ix) The exhaust air from radiator shall be discharge through modular duct duly/ insulated of adequate size. The duct cross section shall be 1.5 times the cross-section of the radiator (radiator X-section is approximately 2mx2m).



5.17 ELECTROSTATIC PRECIPITATOR

5.17.1 General

- i) For the purpose of design of equipment, an ambient temperature of 50°C and relative humidity of 95% shall be considered. The equipment shall operate in a highly polluted environment.
- ii) All equipments shall be suitable for 415V, 50Hz AC supply with voltage variation of (±)10%, frequency variation of (+)3% to (-)5% and combined voltage and frequency variation of 10%.
- iii) All the equipment, material and systems shall conform to the latest edition of relevant national and international Codes and Standards, especially the Indian Statutory Regulations.
- iv) Paint shade shall be as follows :
 - a) TR set : Blue RAL 5012 (Legend in Block letters)
 - b) Motors : Blue RAL 5012
 - c) Panels : Front and rear panels in Grey (RAL9002). End panel sides in blue (RAL 5012)
- v) Technical requirements of ESP Electrical equipment like motors, cables, ACP/MCC etc., which are not covered in the following clauses, shall be as per previous subsections.

5.17.2 Transformer Rectifier (TR) sets

- i) Codes and standards - Transformers shall conform to IS:2026. All other equipment/ accessories shall conform to relevant Indian Standards. Equipment conforming to equivalent International Standard like IEC shall also be acceptable. The transformer oil shall meet the fire safety requirement specified in paragraph 450-23 of National Electrical Code.

- ii) Equipment Description

Type : Silicone oil filled, free standing transformer rectifier assemblies in steel housing with HV disconnect and ground switch for each section of the ESP field. The sets shall be mounted on top of precipitator.

Tank : Welded type construction. Tank cover shall be sloped to prevent retention of water and shall be provided with bi-directional skids, lifting lugs and four jacking pads.

Core : High grade non aging cold rolled grain oriented silicon sheet steel laminations.



	Winding	Electrolytic grade copper.
	Oil	The transformer oil shall be non toxic and shall have high flash point (above 300 ⁰ C) sealed type construction without breather.
	LT Connection	Cable
	Cable box	Degree of protection IP:54
	Bushings	Made of porcelain.
	Marshalling box	Degree of protection IP-54, provided with thermostatically controlled space heaters.
	TR set controller panel	Provided with isolating switch, power contactor, thermal overload relay, fuses for protection of Silicon Controlled Rectifiers etc.
iii)	Fittings	
	Temperature Indicator	Dial type oil temperature indicators with alarm and trip contacts.
	Drip trays	To contain total volume of cooling fluid.
	Drip trays	To be connected to a separator chamber through drain pipes. The separator chamber located at ground level to be sized to contain oil from drainage of any two TR sets.
	Pressure relief device	Spring loaded type.
	Oil level indicator	Magnetic with low level alarm contact
	Oil level gauge	Prismatic/ toughened glass.
	Buchholz relay	Double float type with alarm and trip contacts
iv)	Operating Conditions	
	Operation of precipitator shall not be affected when one rectifier unit is taken out of service.	
	Flux Density	Flux density not to exceed 1.9 Wb/ m ²
	V/F	Designed for 1.1 continuous.
	Noise Level	Not to exceed the values specified in NEMA-TR-1
	Protection	Suitability for working under transient sparking conditions and occasional short circuit load. Protection against surge, excess temperature rise and under voltage to be provided.
	Maximum temperature rise	Winding : 55 ⁰ C Oil : 50 ⁰ C

5.17.3 ESP Insulators

High voltage insulator shall be located outside the gas stream, suitably housed in the insulator compartments to facilitate maintenance when the precipitators are on load. Each insulator compartment shall be provided with insulator heaters or hot air ventilation system to avoid moisture condensation on insulators. In case of hot air system, it shall include fans, air filters, heaters etc.

The insulator compartment shall be provided with thermal insulation. The compartment shall be designed such as to prevent ingress of flue gas into compartments.

Insulators for supporting emitting frame and roof bushing shall be of porcelain suitable for long life, in ESP internal environment (highly polluted with flue gas temperature of 200⁰C and going upto 300⁰C for 5 minutes). Rated voltage for the insulators shall be such that AC rms one minute dry power frequency withstand voltage shall be 1.5 times the DC maximum operating voltage as per relevant IS.

5.17.4 ESP earthing shielding and Safety interlocks

- i) Earthing and shielding
 - a) A complete earthing system with double path to the ground for all equipment and ESP structure shall be furnished. Each casing shall be provided with two earthing pads located on diagonally opposite corners of each casing. The pad surfaces shall be tinned, drilled and shall be connected to earthing mat by 50x6 galvanised steel flats.
 - b) Manual safety earthing switches shall be furnished so that individual equipment can be grounded during maintenance. All access doors, gas distribution baffles or perforated plates located in the inlet or outlet nozzles of the precipitators shall have ground straps connected to the precipitators casing if they are not welded permanently to the casing.
- ii) Safety Interlocks
 - a) A full proof manual key sequence type interlock system for the safety of operating personnel from contacting energised high voltage equipment shall be provided. Key interlocks shall be provided such that for a particular ESP casing any TR set cannot be energised until all insulator housing compartments, disconnect switch boxes, casing inspection doors are locked and emitting and collecting electrode rapping motors are prevented from energisation. It shall also prevent opening of any inspection door unless all TR sets of that stream are de-energised and all HV disconnect switches are opened to earthed position. Rapping motors operation shall be prevented under this condition unless interlock is specifically defeated for testing.
 - b) Key interlock system shall be simple, robust, weather proof construction suitable for outdoor mounting.



5.17.5 ESP Control system

The control system shall be designed for automatic and manual local/ remote operation. ESPs serving one boiler shall be provided with a complete control system consisting of microprocessor based Electrostatic Precipitator Management System (EPMS), TR set controllers, rapper controllers, communication controllers, hopper heater controls, insulator heaters and pressurization system controls and all other controls required for safe, efficient and reliable operation.

- i) Electrostatic Precipitator Management System (EPMS) : The EPMS shall be connected to the Transformer Rectifier Set Controllers (TRC) and Rapper Controllers (RPC) through duplicate data highway. However, any other standard, proven system of communication through balanced current loop is also acceptable. EPMS shall accept the feed back analog signals like Boiler Load Index and Output from opacity monitors, process these signals and issue control parameters to the TR Controllers and Rapper Controllers. It shall also control, monitor and display the status of each stream i.e. status of TR Controllers, Rapper Controllers, hopper heaters, hopper levels, insulator heaters/pressurization air blowers etc.
- 1) The EPMS shall include, but not be limited to, the following features :
 - a) A PC based master controller with non-volatile memory and report storage capabilities for a period of 6 months.
 - b) TR set controllers and Rapper Controllers.
 - c) High resolution 21" colour CRT.
 - d) Communication ports and protocol for data transfer between EPMS Master control unit and the TRC/ RPC/ other controllers.
 - e) Keyboard for operator interface.
 - f) Color inkjet printer for alarms and reports
 - g) Facility for Auto operation of ESP with Energy Management
 - h) Necessary Input/ Output points for interfacing with distributed digital controls and Management information system (DDCMIS).
 - i) Self surveillance and self diagnostic features.
- 2) The EPMS display unit shall display at least the following :
 - a) A summary of the status of all the controllers.
 - b) A summary of the readings of all the TR sets.



- c) A summary about each TRC i.e., settings, limits, voltage and current readings, alarms and the controller status.
- d) A summary of each RPC i.e. controller status, rapping frequency, alarms and indication of the rapper being operated.
- e) Status reading Energy Management System such as charge ratio of each field etc.
- f) Necessary alarms as decided during detail engineering stage.
- g) Status of hopper level, hopper heaters and insulator heater/blower
- h) ESP TR set power supply status and alarm
- i) Potential free contact for ESP trouble shooting etc. as required shall be provided.

The PC based master controller i.e. operating and monitoring station together with 21" colour CRT, keyboard and colour inkjet printer shall be located in the unit control and equipment room/ programmer's room for each unit. Necessary links with the DDCMIS shall be provided so that all the functions of the master controller can be performed from operator's work station of DDCMIS.

- ii) TR set controllers : Each Transformer rectifier set shall be provided with a separate microprocessor based controller (TRC) for regulation and control of the electric power input to electrostatic precipitator fields. It shall be designed for minimum charge ratio of 1:99. It shall automatically optimise the charge ratio and maintain the spark rate at a suitable level for variations of gas temperature, dust composition, gas flow etc. It shall regulate the rectifier in such a way, that the current through the electrostatic precipitator is corrected as the conditions for sparking are changed. It shall be able to monitor filter functioning and shall give an alarm when values are lower or higher than preset values. It shall automatically regulate the charge ratio of each field/ TR set based on V-I characteristics of the respective electrical fields. It shall have alternative arrangement of optimising the charge ratio based on Opacity Monitor signal also. The controller shall have proven noise immunity and shall be suitable for ESP application. It shall be capable of maintaining the optimum voltage and current in ESP under all regimes of boiler operation.

The system shall have the following minimum features :

- a) Display unit for :
 - All the operating values like field DC voltages and currents
 - Spark rate
 - Semi pulse current limit
 - Voltage low limit



- Charge ratio
 - All other adjustable parameters and limits
- b) Keys for operator interface and potentiometers local control and adjustments.
- c) Serial communication with protocol for communicating to EPMS.
- d) Local/ Remote selection.
- e) Spark counter.
- f) Alarms as mentioned below
- TR set oil level low.
 - TR set temperature high.
 - AC current high.
 - Low DC voltage.
 - High DC voltage.
 - Back corona.
 - Management command failure.
 - TR set buchholz / PRV trip
 - TR set buchholz alarm
- iii) Rapper Controller (RPC)

Each stream of ESP shall be provided with a separate, microprocessor based Rapper Controller (RPC). However, any other proven standard design of rapper controller integral to TR set controller is also acceptable. It shall have proven noise immunity and shall be suitable for ESP application. It shall control the sequence and frequency of operation of the rapping mechanisms of collecting and discharge electrodes of the different fields of the precipitator. The unit shall control and survey the operation of rappers in the ESP. It shall start and stop the rappers as programmed and shall give an alarm if a rapper fails. It shall be possible to start or stop manually each rapper, without interfering with the other rappers from the controller. The operation status of each rapper shall be indicated with LEDs on the rapper controller panel.

It shall be possible to change the three timings (viz. start time, repetition time and run time), intensity (if applicable) and frequency of rapping independently for each rapper, without need for opening the panel or any alternation in programme. The range of rapping frequency available shall be upto 24 hrs. Additionally, the rapper controller shall have at least 50 no. pre-programme sequences of rapping stored in its memory so that the operator can select any of them according to his judgment or the controller itself can choose them based on feedback from boiler load.

In case one separate rapper controller is provided for each stream, one standby working rapper controller shall be provided so that in case of failure of any one



of the working rapper controllers, the standby controller shall immediately and automatically take over the control functions of this rapping without affecting the operation of ESP.

The system shall have the following minimum features :

- a) Display of all adjustable parameters, rapping modes, time settings and intensity of rapper/ group and rapper status, rapper alarm and controller alarms.
- b) Key board for operator interface.
- c) Local/ remote selection: In local mode all commands and adjustments shall be from RPC. In remote mode all commands and adjustments shall be from EPMS.
- d) Communication port with protocol for communicating with EPMS.
- e) Remote on/ off capability from EPMS.
- f) The controller address (field programmable), logic programmes and other adjustable parameters shall be stored in non-volatile memory and shall not be affected by power loss.



TECHNICAL SPECIFICATION FOR MAIN PLANT PACKAGE

SECTION- 6 (CONTROL AND INSTRUMENTATION WORKS)

6.1 GENERAL

6.1.1 General Requirements

- i) The bidder shall provide all material, equipment and services so as to make a totally integrated Instrumentation and Control System together with all accessories, auxiliaries and associated equipment ensuring operability, maintainability and reliability. The Instrumentation and Control System shall be consistent with modern power plant practices and shall be in compliance with all applicable codes, standards, guides, statutory regulations and safety requirements in force.
- ii) The bidder shall also include in his proposal and shall furnish all equipment, devices and services which may not be specifically stated in the specification but are needed for completeness of the equipment/systems furnished by the bidder and for meeting the intent and requirements of the specification.
- iii) It may be noted that where equipment or system for the generating units are described, same refer to only one set per generating unit to be furnished by the contractor unless specifically indicated otherwise. Where equipment or systems for plant common facilities are described, it will be understood that the quantities described are the total quantities required.
- iv) The bidder shall include in his bid a detailed bill of material (BOM) for each of the systems i.e. DDCMIS, measuring instruments, power supply system, SWAS etc.
- v) The offered C&I equipment, system, instruments should have completed one (1) year of trouble free and satisfactory operation on a coal fired power station having unit size of 200MW or more.

6.1.2 Reliability and Availability

- i) Each component and system offered by the bidder shall be of established reliability. The minimum target reliability of each piece of equipment like each electronic module/card, power supply, peripheral etc. shall be established by the bidder, considering its failure rate/mean time between failures (MTBF), meantime to repair (MTTR), such that the availability of the complete C&I system is assured for 99.7%.
- ii) The bidder shall submit detailed reliability calculations for each system/equipment which (with the help of a schematic of various sub-system



connected in series or in parallel as the case may be and MTBF & MTTR values for the various equipments) shall show that availability calculation is as per IEEE Standard-P1046 or equivalent.

- iii) When more than one device uses the same measurement or control signal, the transmitter and other components/ module shall be fully equipped to provide all signal requirements. The system shall be arranged so that the failure of any monitoring device or control components or spurious intermediate grounding in the signal path shall not open the signal loop nor cause the loss or malfunction of signal to other devices using the same signal.
- iv) To ensure availability, adequate redundancy in system design shall be provided at hardware, software and sensor level to satisfy the availability criteria mentioned at Cl.6.1.2(i) above. For the protection system, independent sensing device shall be provided to ensure adequate safety of plant equipment.

6.1.3 Standardisation and Uniformity of Hardware

To ensure smooth and optimal maintenance, easy interchangeability and efficient spare parts management of various C&I instruments/equipment, the Bidder shall ensure that all instruments/devices are of the same make, series and family of hardware. For example, all 4-20mA electronic transmitters/transducers, control hardware, control valves, actuators and other instruments/ local devices etc. being furnished by the bidder for steam generator, turbine generator and other auxiliaries shall be of the same make and series for similar applications, except for the instrument integral to TG, boiler and BFP which may be manufacturer specific.

6.1.4 Operability & Maintainability

- i) The design of the control systems and related equipments shall adhere to the principle of 'Fail Safe' operation wherever safety of personnel / plant equipment is involved. 'Fail Safe' operation signifies that the loss of signal or failure of any component shall not cause a hazardous condition. However, it shall also be ensured that occurrence of false trips are avoided / minimised.

The types of failure which shall be taken into account for ensuring operability of the plant shall include but not be limited to:

- Failure of sensor or transmitter,
 - Failure of main and/or redundant controller/other modules,
 - Loss of motive power to final control element,
 - Loss of control power.
 - Loss of instrument air
- ii) The choice of hardware shall also take into account sound maintainability principles and techniques. The same shall include but shall not be limited to the following:
 - Standardization of parts.



- Minimum use of special tools.
 - Grouping of functions.
 - Interchangeability.
 - Malfunction identification facility/self surveillance facility.
 - Easy modular replacement.
 - Fool proof design providing proper identification and other features to preclude improper mounting and installation.
 - Appropriate derating of electronic components and parts.
- iii) The equipment shall employ latest state of the art technology to guard against obsolescence. In any case, bidder shall be required to ensure supply of spare parts for 15 years of the plant. In case, it is felt by the Bidder that certain equipment/component is likely to become obsolete, the Bidder shall clearly bring out the same in his bid and indicate steps proposed to deal with such obsolescence.

6.1.5 Unit Control & Monitoring Philosophy

- i) The control & monitoring philosophy for the plant envisages control from two locations:
- a) From Unit Control Room (UCR)

There shall be one common UCR for controlling the boilers, turbine-generators and auxiliaries of the two units. Accordingly, the layout of UCR shall be developed to accommodate the complete control equipment associated with each unit and the control interface equipment for common facilities as specified.
 - b) From local control stations for off site and ancillary plants

ii) Control & Monitoring from Unit Control Room

The main plant equipment (namely steam generator & auxiliaries, TG & auxiliaries, regenerative cycle equipment, equipment cooling water system etc.) for this project is envisaged to be controlled from the operator workstation (OWS) mounted on the unit control desk (UCD) in the unit control room (UCR) under all regimes of operation i.e. start-up, shutdown, load throw off and emergency handling. In addition, minimum 4 nos. large video-screens of minimum size of 200-210 cm (80"-84") per unit shall be provided. All the information required for safe and efficient operation of the plant shall be displayed on TFTs at high speed and accuracy in specially designed displays suitable for power plant operation. The operation of CW pumps shall be integrated in bidder's DDCMIS with a provision of operation of CW pumps from unit OWS as well as from local control panel to be provided by the CW pump supplier (not in bidder's scope).

Operation of generator, generator auxiliary systems and breakers for 11kV (unit and station switchgears), 3.3 kV switchgear and 415 V associated with the main plant and DG sets shall also be performed through OWS as described in Section-5.



iii) **Back-up Instrumentation**

In addition to the operator work stations (OWS) & large video screens (LVS) mentioned above, minimum amount of conventional push-button (PB) stations and Indicators shall be provided for safe shut down of the unit.

iv) **Control & Monitoring of the Auxiliary Plants in Bidder's scope**

The control, monitoring & operation of the auxiliary plants (i.e. ESP system, centralized oil purification system for TG, condensate polishing system etc.) shall be carried out from local control panel/operator workstation of the respective plants. For all such plant information link shall be provided for collection of data in the DDCMIS in UCR for the information of unit in-charge /shift-in-charge etc.

v) **Information from Other Systems not in Bidder's scope**

The control, monitoring and operation of the off-site plants (i.e. coal handling plant, ash handling plant, fuel oil plant, D.M. plant etc.) will be carried out from the local control panel/operator work station. Bidder shall provide all hardware and software at his end (for minimum 12 systems) for establishing a link for collection of data in the DDCMIS in UCR, shift charge engineer etc. through a station wide LAN. However, as stated above, the operation of CW pumps shall be integrated in bidder's DDCMIS with a provision of operation of CW pumps from unit OWS as well as from local control panel.

6.1.6 Environmental Conditions

Instruments, devices and equipments for location in outdoors/indoor/air-conditioned areas shall be designed to suit the environmental conditions indicated below and shall be suitable for continuous operation in the operating environment of a coal fired station and also during periods of air conditioning failure without any loss of function, or departure from the specification requirements covered under this specification.

Ambient temperature (outside cabinets)	Pressure	Relative humidity	Atmosphere	Required protection Class of panels/ cabinets/ desks
Outdoor Location				
55 degree C max.	Atmosphere	100 % Max.	Air (dirty)	IP 55***
4 degree C min.	Atmosphere	5 % min.	Air (dirty)	IP 55***
Indoor Location				
55 degree C max.	Atmosphere	95 % Max.	Air	IP 54**
4 degree C min.	Atmosphere	5 % min.	Air	IP 54**



Air Conditioned Areas				
24 +/- 5 degree C normal	Atmosphere	95 % Max.	Air	IP 22
50 deg C max. *	Atmosphere	5 % min.	Air	IP 22
* During air conditioning failure.				
** For non-ventilated enclosures. For ventilated enclosures, protection class shall be IP 42.				
***With a suitable canopy at the top to prevent ingress of dripping water..				



6.2 **DISTRIBUTED DIGITAL CONTROL, MONITORING AND INFORMATION SYSTEM (DDCMIS)**

The microprocessor based distributed digital control, monitoring & information system (DDCMIS) shall be provided for the safe and efficient operation of steam generator, turbine generator and all auxiliaries under all regimes of operation.

6.2.1 **General Requirements**

- i) The requirements for distributed digital control monitoring and information system (DDCMIS) are indicated on functional basis in this specification. Bidder shall be responsible for engineering, selection and connection of all components and sub-systems to form a complete system whose performance is in accordance with functional, hardware, parametric and other requirements of this specifications. It is not the intent or purpose of this specification to specify all individual system components since the bidder has full responsibility for engineering and furnishing of a complete system.
- ii) DDCMIS shall basically consist of :
 - a) Control system of boiler, turbine & balance of plant (namely SG - C&I, TG - C&I & BOP - C&I including their respective measurement system);
 - b) Man-Machine interface and plant Information system (MMIPIS);
 - c) System programming & documentation facility;
 - d) Data communication system (DCS);
 - e) Sequence of events (SOE) recording system;
 - f) Annunciation system;
 - g) Master & slave cock system.
- iii) **System Expandability**

Modular system design shall be adopted to facilitate easy system expansion. The system shall have the capability and facility for expansion through the addition of controller modules, process I/O cards, drive control modules, hand/auto stations, push button stations, peripherals like TFT/Keyboards, printers etc. while the existing system is fully operational. The system shall have the capability to add any new control loops groups/subgroups, in control system while the existing system is fully operational.
- iv) **On Line Maintenance**

It shall be possible to remove/replace online various modules (like I/O module) from its slot for maintenance purpose without switching off power supply to the corresponding rack. System design shall ensure that while doing so, undefined signalling and releases do not occur and controller operation in any way is not affected (including controller trip to manual, etc) except that



information related to removed module is not available to controller. Further, it shall also be possible to remove/replace any of the redundant controller module without switching off the power to the corresponding rack and this will not result in system disturbance or loss of any controller functions for main controller. The on-line removal/insertion of controller, I/O modules etc. shall in no way jeopardise safety of plant and personnel.

v) Fault Diagnostics

The DDCMIS shall include on-line self-surveillance, monitoring and diagnostic facility so that a failure/malfunction can be diagnosed automatically down to the level of individual module giving the details of the fault on the programmer station TFT displays and printers. The faults to be reported shall include fault in main and standby power supplies, sensor fault, any channel fault in 2V3 channels etc. These faults shall be indicated on TFTs as well as local indication on the faulty channel/ module and on corresponding rack/ cubicle. The diagnostic system shall ensure that the faults are detected before any significant change in any controller output has taken place. Failure of any I/O modules, controller etc. shall be suitably grouped and annunciated to annunciation facia and to OWS.

vi) Fault Tolerance

The DDCMIS shall provide safe operation under all plant disturbances and on component failure so that under no condition the safety of plant, personnel or equipment is jeopardised. Control system shall be designed to prevent abnormal swings due to loss of control system power supply, failure of any control system component, open circuits/short circuits, instrument air supply failure etc. On any of these failures, the controlled equipment/parameter shall either remain in last position before failure or shall come to fully open/close or on/off state as required for the safety of plant/personnel/equipment and as finalised during detailed engineering.

vii) Signal Exchange

All the signal exchange between various functional groups of each control group (i.e. within SG - C&I, TG - C&I and BOP - C&I) shall be implemented through redundant main system bus (the main bus connecting various sub-systems) and local system bus within a sub-system as per the standard practice of the bidder. It shall be ensured that any single failure in electronics involved for such communication, e.g., communication controllers, bus interface modules, physical communication media, etc. does not result in loss of such signal exchange and there in no deterioration in specified system response and system parametric requirements. In case a controller utilises some inputs generated/ processed by any other controllers/functional group and the requirement of controller response time as specified elsewhere is not met due to inadequate communication rate/ procedure, then the bidder shall provide hardwired signal exchange for such inputs. Bidder shall furnish documentary evidence through its standard catalogues and drawings explaining as to how this requirement is being met by them.-Further, bidder to note that if his offered system cannot meet the above requirement of



communication redundancy and specified system response and parametric requirements then all the signal exchange, analog as well as binary among various functional groups shall be carried out through hardwiring only and not through bus system.

However, if in the opinion of the purchaser, a few signal exchanges are found required to be hardwired, the same shall be provided by the bidder. Control & protection signal exchange between SG- C&I, TG-C&I and BOP - C&I shall be hardwired only. Protection signals like MFT shall necessarily be hardwired even for exchange within the same sub-system.

No single failure either of equipment or power source shall be capable of rendering any part/system/sub-system of DDCMIS in-operative to any degree.

viii) System Spare Capacity

Over and above the equipment and accessories required to meet the fully implemented system as per specification requirements, DDCMIS shall have spare capacity and necessary hardware/ equipment/ accessories to meet following requirement for future expansion at site:

- a) 10% spare channels in each of the functional groups, fully wired upto marshalling cabinets.
- b) Wired-in "usable" space for 20% modules in each of the system cabinets for mounting electronic modules wired up to corresponding spare terminals in marshaling cabinets such that implementation of any additional control loop/logic can be achieved only by insertion of necessary electronic modules(s) in system cabinets, configuration of corresponding controller and connection of inputs/ outputs at 'field end' of marshaling cabinet / logic cabinet as applicable.
- c) MMIPIS shall be provided with capacity to handle 25% or at least 1 no. of each type of peripherals additionally, like TFTs, keyboards, printers, PCs etc., over and above already specified, without any additional hardware or software.
- d) Each controller shall have 30% spare functional capacity to implement additional function blocks, over and above implemented logics/ loops. Further, each controller shall have spare capacity to handle minimum 20% additional inputs/ outputs of each type (including (a) & (b) above), over and above implemented capacity. Each of the corresponding communication controller shall also have same spare capacity as that of controller.
- e) The data communication system (including main system bus and other bus system) shall have the capacity to handle the additions mentioned in clause nos. (a) to (d) above. This will be in addition to 50% spare capacity specified under this clause.



- f) Twenty (20) percent spare relays of each type and rating, mounted and wired in relays cabinets. All contacts of relays shall be terminated in terminal blocks of relay cabinets. In each of the relay cabinets 20% spare terminal blocks shall be provided so that additional relays can be mounted and wired.
- g) The spare capacity as specified above shall be uniformly distributed throughout all cubicles. The system design shall ensure that above mentioned additions shall not require any additional controller/ processor/ peripheral drivers in the system delivered at site. Further, these additions shall not deteriorate the system response time/ duty cycle, etc. from those stipulated under this specification.
- ix) Remote Input Modules and Cubicles

It is envisaged to use remote input modules and racks / cubicles at the following locations in the plant to the extended I/O bus, to minimize cabling. The exact areas where remote I/O modules are provided shall be decided during detailed engineering. However some of the areas where such remote I/O can be provided are listed below:

- a) Boiler area (for metal temperature etc.)
- b) Near transformer yard for various inputs related to transformers.
- c) SWAS room.
- d) Switchgear room

It is mandatory to provide a small room or enclosure for above which will be properly air conditioned through window a/c so that environment similar to control equipment room is met. However, the modules used for the above application shall be designed in such a way to withstand the harsh environment expected to be encountered in respective plant areas.

6.2.2 System Description

The DDCMIS shall work in full integration and conjunction with field equipment/drives like pumps, motors, valves, actuators, dampers, hydraulic control systems (e.g. for HP&LP bypass etc.) and field instruments to be provided by the bidder. The DDCMIS hardware (controllers, modules/cards etc.) shall be housed in cabinets located in control equipment room (CER) except for operation interfaces located in unit control desk (UCD) and unit control panel (UCP), if applicable, in unit control room (UCR).

i) **Control System**

The control system along with its measurement system, shall perform functions of closed loop control, sequence control, interlock & protection of SG, TG and auxiliaries under all regimes of unit operation. The measurement



system of control system shall perform the functions of signal acquisition, conditioning and signal distribution of various types of inputs/outputs like analog, (4-20 mA DC, thermocouple, RTD), binary, pulse, etc. The inputs which are required for only information and monitoring purposes shall be distributed suitably in various groups of the measurement system.

ii) **Man-Machine Interface and Plant Information System (MMIPIS)**

The MMIPIS shall perform control, monitoring and operation of SG, TG and auxiliaries under all regimes of unit operation, interacting with the control system. For this, MMIPIS shall primarily perform following functions.

- a) Operator interface for control system
- b) Plant supervisory functions like displays, alarm monitoring & reporting, (reports & logs, calculations, trend recording, historical and long term data storage & retrieval, etc.)

iii) **System Programming & Documentation Facility**

The programmer stations shall be provided for

- a) on-line configuration & tuning of control system
- b) on-line program development/modifications in MMIPIS

In addition, latest state of the art work-station based system documentation facility shall be provided to retrieve, generate & document all system documentation, logics, control loops, cable interconnection, etc. to achieve paperless documentation for the complete plant.

iv) **Data Communication System (DCS)**

The data communication system shall be provided for communication between control system and MMIPIS communication and signal exchange between various functional groups as well as communication between various units & off site / off line systems.

v) **Sequence of Events Recording System (SOE)**

The DDCMIS shall be capable of carrying out sequence of event recording function to scan and record events in the sequence of occurrence within a resolution of one (1) m sec.

vi) **Master and Slave Clock System**

Master and Slave Clock System shall be provided to ensure uniform time indication throughout the various plant facilities and time synchronisation between control system, MMIPIS, switchyard disturbance recorder, other PLC's etc.



vii) **Annunciation System**

Annunciation system shall be LVS based in the unit control room. The annunciation logic will be implemented as a part of DDCMIS. Top portion of all the LVS shall be reserved for annunciation with 3/4 bands for different priority.

6.2.3 Measurement Functions of Control System

All the signals coming into/going out of the control system shall be connected either directly or routed through marshalling cabinets as per the interconnection philosophy of DDCMIS. The input / output modules employed in the control system shall be separate from controller hardware. .

6.2.3.1 Analog signal conditioning & processing

- i) The conditioning and processing functions to be performed as a minimum for the analog inputs coming for control and information purposes are :
- a) Galvanic isolation of input and output signals wherever required.
 - b) Transmitter power supply with per point fuse protection or current limiting and power supply monitoring.
 - c) Transducer/transmitter signal output limit check
 - d) Implementation of multiple measurement schemes
 - e) Square root extraction
 - f) Pressure and temperature compensation.
 - g) On-line analog digital converter (ADC) gain and drift monitoring and correction at periodic intervals.
 - h) Linearisation of thermocouple signals
 - i) Reasonability check for all analog inputs.
- ii) All analog signals for control purpose shall be acquired, validated, processed and their respective data base updated at a maximum interval of 250 milliseconds except for some fast-acting control loops for which the above-referred time shall be as per process requirement. For signals required for information only, the above functions shall be performed at an interval of 1 – 2 sec. The validated analog inputs shall be converted into engineering units on a per point basis. Analog input processing (scanning to alarm checking) shall be performed once every scan cycle. It shall be possible to delete any analog input from scan or to return it to scan on demand by the operator.
- iii) The 4-20 mA input analog cards shall be suitable for interfacing transmitters giving 4-20mA analog signal along with superimposed HART interface
-



signals. 4-20 mA DC signal will only be used for control purpose and superimposed HART signal will be used for configuration, maintenance diagnostic and record keeping facility for electronic transmitters and analysers etc. meeting the functionalities described elsewhere.

6.2.3.2 **Binary signal conditioning & processing**

- i) The changeover type contacts (i.e. 'NC' + 'NO' together) shall be wired to the control system for all the binary inputs required for control purposes, except for inputs from MCC/switchgear, actuators and inputs related to hardwired signal exchange among various functional group for which non-changeover type contacts ('NC' or 'NO') shall be wired to the control system. The binary inputs required for information purposes only shall be wired to control system in the form of non-changeover type contacts.
- ii) The conditioning and processing functions to be performed as a minimum for the binary inputs coming for control and information purposes are:
 - a) 24V / 48 VDC power supply for contact interrogation for all potential free contacts with per point fuse protection or suitable current limit feature/ isolation through opto-coupler.
 - b) Contact bounce filtering delay time of 15 milliseconds.
 - c) Facility for pegging the binary signal to logic one/zero or last correct value in case of failure of binary input module.
 - d) Binary signal distribution to different users shall be in such a way so as to ensure that a short/ground fault on one user is not reflected to the other user.
 - e) Implementation of multiple measurement schemes for signals for control purpose.
 - f) All binary signals shall be acquired, validated, processed, alarm checked and their data base updated within one second. In addition to this requirement, binary signals required for SOE shall have a resolution of 1ms.
 - g) Checking for excessive number of status changes for all binary/contact inputs.
 - h) Facility to delete any binary input from scan or to return to scan on operator demand.
 - i) The non-coincidence monitoring shall be provided for binary inputs for all changeover signals, namely process actuated switches required for control purpose (i.e. protection/interlock, permissive, logical intervention etc.)



- iii) Triple measurement scheme for analog inputs employing three independent transmitters connected to separate tapping points shall be employed for the most critical measurements used in analog control functions including but not limited to furnace draft, feed water flow, throttle pressure, turbine first stage pressure, drum level, deaerator level, turbine speed.

The three signals shall be auctioneered to determine the median/average value which will be used for control purpose. In case one transmitter fails or shows excessive deviation with respect to others, it will be removed from computation of median/average value and the average of the other two transmitter outputs shall be used for controls. The control loop shall trip to manual when any two of the three transmitter signals fail. The operator shall be able to select any of the transmitters or the median/average value from the control desk. The outputs of the transmitters shall be continuously monitored for excessive deviation which shall be displayed, logged and alarmed.

Individual transmitter signal, their status and selected value for control/measurement shall be available on OWS.

- iv) Dual measurement scheme for analog inputs employing two independent transmitters, connected to separate tapping points/ temperature element shall be employed for the remaining measurements used for analog control functions.

The output of the redundant transmitters shall be continuously monitored for excessive deviation. In case the deviation is within limits, the mean value shall be used for the control loop. If the deviation becomes high (with both transmitters remaining healthy), the loop will be automatically transferred to manual. However, if one transmitter fails and the other transmitter remains healthy, then the output of the healthy transmitter shall be used for control. If the other transmitter also fails, loop shall trip to manual. The outputs of the transmitters shall be continuously monitored for extensive operation which shall be displayed and logged and alarmed.

Individual transmitter signal, their status and selected value for control/measurement shall be available on OWS.

- v) For binary and analog inputs required in furnace and turbine protection triple sensing devices shall be provided. Binary and analog inputs which are required for protection of more than one equipment (e.g. flame failure, deaerator level very low, etc) as well as protection signals for turbine driven boiler feed pump (TDBFP)/ motor driven boiler feed pump (MDBFP), triple sensing devices shall be provided. For other critical binary and analog inputs required for protection and interlock purpose of other equipment (e.g. those interlocks which may result in loss of generation, non-availability of a major equipment etc.), dual sensors shall be provided. However, for bearing temperature of FD/ID/PA/MILLS/APH and its HT drives, single sensor shall be used.



- vi) Wiring scheme for inputs to control system shall be as follows :
- a) Each of the dual/ triple redundant binary and analog inputs shall be wired to separate input modules. In addition, for functions employing 2V3 controllers like BMS/turbine protection, each of the redundant binary and analog signals shall be wired to separate input modules associated with each controller and meeting requirement stipulated under clauses 6.2.4.2 & 6.2.4.3. Similarly, each of the dual redundant binary and analog inputs shall be wired to separate input modules. These redundant modules shall be placed in different racks, which will have separately fused power supply distribution. Implementation of multiple measurement scheme of these inputs will be performed in the redundant hardware. Loss of one input module shall not affect the signal to other module and also other channels of these modules can be used by other inputs of the same functional group.
- b) The single binary and analog signals required for control purposes shall be wired as follows:
- The limit & torque switches and the MCC/ Swgr checkbacks shall be wired to drive control modules wherever provided. For the drives where drive control modules are not provided, these signals shall be connected to input module only.
 - Other single analog & binary inputs shall be wired to single input modules.
- vii) The binary and analog outputs from one subsystem of the Control System to other which are required in these systems for control purposes, (only very few critical signals e.g., reheater protection or MFT, load set point to electro hydraulic turbine control (EHTC) from CLCS, etc.), shall be made available from triple/dual redundant binary and analog output modules. However, redundancy in binary and analog outputs to indicators/recorders, SOE and annunciation facia lamps is not required.
- viii) The signal conditioning functions like multiple measurement schemes, square root extraction for flow signals, pressure and temperature compensation, limit value computation can be performed either in the controllers or in signal conditioning and processing hardware outside controllers.
- ix) The maximum number of inputs/outputs to be connected to each type of module shall be as follows:
- | | | | |
|----|----------------------------------|---|----|
| 1. | Analog input module | - | 16 |
| 2. | Analog output module | - | 16 |
| 3. | Binary input module | - | 32 |
| 4. | Binary output module | - | 32 |
| 5. | Analog input & output (combined) | - | 16 |



6. Binary input and output (combined) - 32

(**Note :** For binary inputs, one changeover contact is counted as 2 inputs)

Further, minimum 10% spare channels shall be kept in each of the input/output modules.

- x) The following requirements shall be met :
- a) Input filters to attenuate noise shall be provided.
 - b) All analog outputs shall be short circuit proof.

Any single sensor/transducer/transmitter failure alarm shall be provided on programmer station TFTs for all sensors/ transducers/ transmitters. Similarly sensor break alarm for thermocouples etc. shall also be displayed on the TFTs.

6.2.4 Control System Requirements

6.2.4.1 The control system shall be broadly divided into SG - C&I, TG - C&I and BOP - C&I.

- i) The SG- C&I part of DDCMIS system shall perform the following function as minimum but not limited to
 - a) Burner management system (BMS) including control & protection of coal mills, fuel oil system etc.
 - b) Analog control functions pertaining to secondary air damper control etc.
 - c) Soot blower control.
- ii) The TG- C&I part of DDCMIS system shall perform the following functions:
 - a) Turbine protection system function (TPS)
 - b) Turbine governing system for main turbine
 - c) Turbine stress control system (TSCS)
 - d) Automatic turbine testing (ATT)
 - e) Automatic turbine run up system. (ATRS)
 - f) HP&LP bypass control system
 - g) Turbine generator control system
 - h) EHG, interlock & protection for turbine driven BFP



- iii) The BOP- C&I system shall perform the following functions:
- a) Analog control functions, other than those covered in SG-C&I and TG-C&I, like co-ordinated master control, furnace draft control, SH/RH steam temperature control, FW flow control, heaters/deaerator/condenser level control, Auxiliary PRDS pressure & temperature control etc.
 - b) Binary control functions pertaining to main plant auxiliaries like FD/ID/PA fans, APH, BFP etc., Generator auxiliary systems and electrical breakers etc.
- iv) Functional grouping of various controllers shall be decided during detailed engineering which shall be subject to purchaser's approval. Functional grouping shall meet following general requirements:
- a) Process redundancies shall be maintained. For example, in case the mechanical equipment has been provided with redundancy, the drive shall not be controlled by a common controller i.e. for redundant set of process equipments(eg.2x60%ID fans,3x60% CEP etc.),it shall be ensured that there is no sharing of controller components between independent groups.
 - b) Stream concept shall be maintained. The different equipment shall be clubbed in such a manner that failure of a controller set affects only one stream of the process path, eg. in air and flue gas path, ID-fan A, FD-fan A, and secondary rotary air pre heater –A can be clubbed on one set of controllers.
 - c) Inter-related controls shall be provided in one group, i.e. when the loop /sequence of one equipment depends on the availability of another sequence /loop or equipment than these controls shall be preferably be clubbed together eg. PA fan controls depend on the availability of mills/mill control, so, control of half the number of mills can be clubbed with control of the relevant PA fan.
 - d) Failure mode analysis, i.e while formulating the controller group, it shall be ensured that the failure of one function does not jeopardize the plant operation or cause shut down. For example if 6 mills are required for full load plant operation, then the grouping of mills shall be done in such a manner that not more than 3 mills shall be clubbed in one set of controller.

For each of the functional groups, separate sets of controllers, I/O modules, communication controllers, power packs/ modules etc. shall be provided. Mixing of hardware of two or more functional groups (FG) shall not be acceptable. It shall be ensured that failure of any set(s) of hardware of any FG does not affect other FG(s) and data communication between other FG(s) and MMIPIS.



- v) The minimum functions to be realised in each of the above mentioned control systems shall be as per requirements specified under subsequent clauses of this specifications. The bidder shall provide all hardware/software, whether or not specifically indicated in this specification to fully meet operational, maintenance, safety requirements as well as conform to international standards and proven practices.
- vi) The control system shall function reliably under the environmental conditions as specified under cl. no.6.1.6 of this specification. It shall be immune from the interferences resulting from disturbances in power supply feeders, signal lines, inputs, outputs, etc. as experienced in a coal fired power station.
- vii) The control system shall have on-line simulation and testing facility. Further, it shall be possible to on-line configure and tune controllers through configuration and tuning station for control system.
- viii) The system shall have the flexibility to easily reconfigure any controller at any time without requiring additional hardware or system wiring changes and without disabling other devices from their normal operation mode. Modifications shall not require switching off power to any part of the system.
- ix) The executive programs for the controller modules shall be firmware based, which shall be non-volatile and shall not be alterable except by replacement of parts. The application programs for the functional controllers shall be software based which shall be maintained through power supply failure. The application program shall be alterable through the configuration and tuning station for all configuration and strategy changes, etc., and through the operator's console for set point/bias changes, device selection, etc. Parts replacement or parts removal shall not be required in order to accomplish changes in application programs including system tuning.

In case it is bidder's standard practice to have the application programs also firmware based (i.e. EPROM/ EEPROM), then the same is also acceptable. However, in that case, Bidder shall provide necessary programming device including EPROM writer/eraser etc. (2 Nos. per unit).

- x) All the 100% hot/redundant backup controllers shall be identical in hardware and software implementation to their corresponding main controllers and shall be able to perform all its tasks. The backup controller shall track its corresponding main controller. There shall be an automatic and bumpless switchover from the main controller to its corresponding backup controller in case of main controller failure and vice versa without resulting in any change in control status. In case of switchover from main controller to the 100% hot backup controller, the back-up controller shall work as the main controller.

Facility shall also be provided for manual switchover from main to 100% hot back-up controller and vice versa from the programmer's console.

The control system hardware design shall be such that it is able to withstand power line disturbances as per relevant standard.



6.2.4.2 **Burner Management System (BMS)**

- i) Fully proven microprocessor based system, based on hardware and software proven for burner management application shall be provided to achieve the boiler protection e.g. master fuel trip (MFT), control of mills & fuel oil systems etc.
- ii) The BMS shall be provided with automatic self monitoring facility. All modules to be used in this system shall be of fail safe design. Any single fault in any primary sensor, I/O modules, multifunction controllers, etc. should not result in loss of safety function. All faults should be annunciated to the operator, right at the time of its occurrence and also for alarm annunciation facia.

The BMS shall meet all applicable relevant safety requirements including those stipulated in latest editions of VDE 0116, Section 8.7, VDE 0160, NFPA 8502/ 8503 etc.

The suggested configuration of the MFT sub- group of BMS shall be submitted. The exact implementation shall be subject to Purchaser's approval during detailed engineering.

- iii) The MFT functions shall be implemented in a fault tolerant 2 out of 3 triple redundant configuration. Each of the three independent channels shall have its own dedicated processors, multi-function controllers, communication controllers, I/O modules, interface etc. All safety related process inputs shall be fed to each of the 3 channels. All the primary sensors for unit/boiler protection shall be triple redundant.
- iv) The acquisition and conditioning of binary and analog protection criteria signals for MFT shall be carried out in each of the three triple redundant channels. Each channel shall compute the 2 out of 3 voting logic and issue a trip command. The trip signals of the three channels shall be fed to a fail safe 2 out of 3 relay tripping unit for each drive. The protection criteria for tripping shall be executed by a program which shall be identical in each of the triple redundant channel. The check back contact signals of each relay of the 2 out of 3 relay tripping unit shall be fed back to each of the triple redundant channels and shall be continuously monitored for equivalence in each of them
- v) The BMS shall be designed to :
 - a) Prevent any fuel firing unless a satisfactory purge sequence has first been completed.
 - b) Prevent start-up of individual fuel firing equipment unless permissive interlocks have first been satisfied.
 - c) Monitor and control proper equipment sequencing during its start-up and shutdown.



- d) Provide equipment status feed back and annunciator indication to the unit operator.
- e) Provide flame monitoring when fuel-firing equipment is in service and effect a burner trip or master fuel trip upon warranted firing conditions.
- f) Continually monitor boiler conditions and actuate a master fuel trip (MFT) during adverse operating conditions which could be hazardous to equipment and personnel.
- g) Reliably operate and minimize the number of false trips.
- h) Provide a master fuel trip relay independent of processors and I/O modules to provide a completely independent trip path.
- i) Provide all logic and safety interlocks in accordance with National Fire Protection Association (NFPA).
- j) Include a first out feature in all controllers to identify the cause of any burner trip or boiler trip.
- k) Provide a complete BMS diagnostic system to immediately identify to the operator any system module failure.
- l) Allow burners and igniters to be started, stopped and tripped on a burner basis.
- m) Allow the automatic start and stop of burners based on boiler load. The sequence of which burner will be started or stopped will be selected by the operator from a TFT display.

6.2.4.3 **Turbine Protection System (TPS) Functions**

- i) Fully proven microprocessor based system, based on hardware and software proven for turbine protection application for the same turbine being offered for this project, shall be provided to achieve the turbine protection action.
- ii) The Turbine Protection System shall meet all applicable safety standards/requirements including those stipulated in VDE 0116 Section 8.7. The system design shall be such that safety function of the total system must not be jeopardized on occurrence of fault. Any single fault in either primary sensor, input/output modules, controller module etc. shall in no way jeopardise the safety of the turbine. All modules to be used in this system shall be of fail safe design.
- iii) The Turbine Protection System shall also be implemented in 2 out of 3 voting logic. Three independent trip channels each having its own and dedicated processing modules, controllers, input/output modules etc. shall be provided



to achieve 2 out of 3 voting logic. The outputs of the three channels will be used to implement 2 out of 3 voting logic in two relay units, the output of which will be fed to the two turbine trip relays.

As an alternative, bidder may also propose two independent trip channels, each having its dedicated processing module with hot backup. Two out of three voting logic will be implemented in each of the channels and the output of each channel to be fed to each of the two turbine trip relays.

Turbine shall be tripped when either of the above two trip relays operates. The exact implementation shall be subject to purchaser's approval during detailed engineering.

- iv) All the input signals (trip signals etc. from the field devices) shall be fed in parallel to all the two/three redundant channels of protection system as mentioned above via signal conditioning cards designed for such application. Further, the computation of field input voting logics i.e. 2 out of 3 etc. shall also be performed in the controllers of all the three/two channels of protection system which will then perform the computation of 2 out of 3 voting logic independently.
- v) Bidder shall provide all the required primary sensors etc. required for protection system as per his standard and proven practices. All trip signal inputs required for the safety of the turbine shall be based on 2 out of 3 logics. The system shall include turbine lock-out relays, redundant turbine trip solenoids and necessary hardware required for testing.
- vi) The tripping devices shall be designed to operate on DC supply. The trip coils shall be monitored continuously for healthiness and failure shall be alarmed.

6.2.4.4 **Binary Controls/Open Loop Control System (OLCS) Function**

This clause is applicable for the binary controls of SG-C&I and TG-C&I [6.2.4.1 (i) & (ii)] and BOP - C&I [6.2.4.1(iii)].

- i) The OLCS shall include sequence control, interlock & protection for various plant auxiliaries, valves, dampers, drives etc. The sequence control shall provide safe and automatic startup and shutdown of plant and of plant items associated with a plant group. The interlock and protection system shall ensure safe operation of plant/plant items at all times and shall automatically shut down plant/plant items when unsafe conditions arise.
- ii) The OLCS shall be arranged in the hierarchical control structure consisting of unit level, group level, subgroup level & drive level (as applicable).

It shall be possible to perform automatic unit startup & shutdown by issuing minimum number of command from the OWS. Thus, the unit level shall control all the control system blocks and issue appropriate startup and shutdown commands to various blocks of control system.



The group level shall control a set of functional sub-groups of drives. Appropriate start-up and shut down commands shall be issued to the sub-group control and various checkbacks shall be received from sub-groups or drives. Each sub-group shall execute the sequential start-up and shut down programmes of a set of inter-related drives along with system interlocks and protections associated with that sub-group as well as basic interlocks and protections related to individual drive falling under that sub-group. The drive level shall accept commands from the sub-groups, push buttons (wherever provided), etc., and transmit them to the respective drive, after taking into account various interlocks and protections and the safety of that particular drive.

- iii) A sequence shall be used to move a set of groups and sub-groups from an initial steady state (for instance 'OFF') to a final steady state (for instance 'ON'). The sequence initiating command for the unit and group level shall be issued from TFT/KBD.
- iv) A sequence shall be made of steps. The steps shall be executed in predetermined order according to logic criteria and monitoring time consisting of the interlock & protection requirements and checkback of previous step which shall act as pre-conditions before the sequence control can execute the command for that step.
- v) Each step shall have a "waiting time" implying that the subsequent step would not be executed unless the specified time elapses. A monitoring time shall also be defined as the maximum time required in executing the commands of any step and the time required for appearance of check back signals. In case, this is not completed within the specified time, a message shall be displayed and programme will not proceed further.
- vi) Manual intervention shall be possible at any stage of operation and the sequence control shall be able to continue at the correct point in the programme on return to automatic control. Protection commands shall have priority over manual commands, and manual commands shall prevail over auto commands.
- vii) Open or close priority shall be selectable for each drive.
- viii) The sequence startup mode shall be of the following types.
 - a) **Automatic Mode**

In this mode of operation, the sequence shall progress without involving any action from the operator. The sequence start/stop command shall be issued from the TFT/KBDs.
 - b) **Semi-Automatic Mode**

In this mode of operation, once the sequence is initiated, the step progressing shall be displayed on the TFT. But the step execution command shall be prevented and shall be sent by the operator via the keyboards. It shall be possible to bypass and/ or simulate one or more



criteria to enable the program to proceed. This facility shall allow the program to be executed even if some criteria are not fulfilled because of defective switching device, etc., while the plant condition is satisfactory. All the criteria bypassed shall be logged and displayed. It shall be possible to put the system on the auto-mode after operating it on semi-automatic mode for some steps or vice-versa, without disturbance to the sequence operation.

c) **Operator Test Mode**

It shall be possible to use the sequential control in operator guide mode/ test mode i.e. the complete system runs and receives input from the plant and the individual push button stations (where provided)/ keyboards but its command output is blocked. The whole programme, in this case shall run in manual mode. This mode shall allow the operator to practise manual operation using step and criteria indications. The actual protection should remain valid during this mode of operation also.

- ix) The sequence shall be started by putting the sequence on 'auto' and on receipt of 'start' command from the OWS or from a higher level group/ protection action as defined. The sequence shall then progress as per the defined logics. It should be possible to select alternative operation in the same sequence depending on certain process/ equipment condition. Some step can be automatically bypassed also based on certain process/ equipment condition. When the expected results of the sequence are reached the sequence is considered as "End".

If during sequence initiation or sequence progressing or during normal running of the drive, a shutdown criteria is present, the sequence shall be stopped and the shut down sequence initiated.

- x) For the drives, the command shall be provided through redundant output module and inputs (status, switchgear & process) shall be acquired through input modules. The drive logic shall be implemented in the redundant controller.

The status for the 11 KV, 3.3 KV drives and some other important drives (total approximately 40 nos. per unit) shall also be wired in parallel to redundant input modules so that on failure of the single input modules, the information regarding the status of the affected drive remains available in OLCS.

- xi) The output modules control module shall have the feature that ensures that in case of failure, all the outputs are driven to zero. The 24V DC command outputs to drives for on/open, off/close shall be separate and independent and inverted outputs shall not be employed. For inching type of drives, position transmitter power supply and monitoring of position transmitter signal shall be provided.



- xii) The termination for open/ close command for the drive actuator shall be performed in the actuators with integral starter specified elsewhere in the specification. However, open/ close and disturbance status as a minimum shall be monitored in OLCS.

The sequence interlock & protection requirements shall be finalised during detailed engineering and the same shall be subject to Purchaser's approval.

- xiii) The OLCS shall also include the control of electrical systems in addition to the auxiliaries of boiler & turbine such as open/close or on/off etc. of various electrical systems such as generator, generator auxiliary systems, breakers of 11kV, 3.3 kV, 415 V switchgears, synchronisation of unit etc. as described in Section -5. All the features and specification requirements as specified above shall also be applicable for electrical system.

6.2.4.5 **Analog Controls/Closed Loop Control System (CLCS) Functions**

This Clause is applicable for analog controls of SG - C&I [6.2.4.1(i)], BOP-C&I [2.4.1(iii)] and TG - C&I [6.2.4.2(ii)].

The CLCS shall continuously act on valves, dampers or other mechanical devices such as hydraulic couplings etc., which alter the plant operation conditions. The system shall be designed to give stable control action in steady state condition and for load changes in step/ramp over the load range of 60% to 100% MCR with variation or parameters within permissible limits to be finalised during detailed engineering state. The system shall have the following minimum features:

- i) The controller capability shall, as a minimum, include (i) P, PI, PD and PID control functions and their variations (ii) cascade control (iii) feed forward control (iv) state-variable based predictive control for SH/RH temperature control (v) on-off control, (vi) ratio and bias control, (vii) logical operation etc.

The loop reaction time (from change of output of the sensor of the transmitter/temperature element to the corresponding control command output) shall be within 500 milli seconds. However, for faster loops such as feed water, furnace draft, PA header pressure control loop etc. the same shall be based on actual process requirement but shall not be more than 250 milli second.

- ii) The control system shall be bumplessly transferred to manual on the following conditions as a minimum and as finalised during detailed engineering.

Control power supply failure, failure of redundant controllers, field input signal not available, analog input exceeding preset value, etc.



- iii) Any switch over from auto to manual, manual to auto and switchover from TFT operation to auto manual station operation and vice versa shall be bumpless and without resulting in any change in the plant regulations and the same shall be reported to the operator.
- iv) Buffered analog output (positioning signal) of 4-20mA DC shall be provided from CLCS to the respective E/P converters. For electrical actuators, pulse type output (bound less control) shall be preferred. CLCS shall also provide all the necessary outputs for indicators & recorders with output loop resistance of 500 ohms for each channel of the output module.
- v) The functional requirement of the CLCS loops as well as the detailed schemes shall be finalised during detailed engineering stage and shall be subject to Purchaser's approval.
- vi) The system being supplied shall be such that when permissible limits are exceeded, an automatic switchover from an operation governed by maximum efficiency, to an operation governed by safety and availability is affected.
- vii) For safety reasons, switchover logics associated with the modulating control loops, shall be performed within the closed loop control equipment.
- viii) Time supervision facility shall be provided to monitor the final control element.
- ix) It shall be possible to block the controller output on a pre-programmed basis.
- x) All controllers shall be freely configurable with respect to requisite control algorithms.
- xi) Whenever, alternate measurement is available for a control input the alternate measurement value will be automatically substituted in the control loop in case of loss of control input. All necessary software for switching and reconfiguration shall be provided. In addition, such substitution shall be balanceless and bumpless and shall be reported to the operator.

6.2.4.6 **Turbine Control System (TCS) Functions**

The Turbine control system shall consist of turbine governing system, turbine stress control system and BFP turbine Electro-hydraulic governing system HP&LP bypass system & automatic turbine testing (ATT) system. In addition to the specific requirements indicated in subsequent clauses, the requirements of CLCS as elaborated in clause 6.2.4.5 shall also be applicable for TCS.

- (i) **Turbine Governing System**
 - a) Following two alternatives for the turbine governing system shall be acceptable and bidder shall offer one of these alternatives based on his proven & standard practices.



Alternative - I

In this alternative, the turbine generator unit shall be equipped with electro-hydraulic governing (EHG) system backed-up by mechanical-hydraulic control system. The system shall be designed such that the governing of the steam turbine shall be automatically and safely transferred to mechanical hydraulic control system during operation, in the event of a fault developing in electro-hydraulic control system.

Alternative - II

In this alternative, the EHG system shall be provided with 100% hot redundancy i.e. the system shall consist of two independent channels right from sensors, transmitters, other field mounted devices, input modules, controller modules, output devices etc. of the electro hydraulic converter. Further, each of these channels shall be fed from independent power supplies.

- b) Both the above mentioned alternatives shall meet the following functional requirements.

The controls covered in this system shall basically consist of speed controller, load controller, valve-lift controller, inlet steam pressure controller and output frequency droop characteristic controller. The speed controller shall ensure controlled acceleration of the turbine generator and shall prevent overspeed without tripping of the unit under any operating condition or in the event of full load throw-off.

The speed controller shall limit the overspeed of the turbine on loss of full load to a value less than 8% of rated speed. The governing system shall be equipped with speed/load changer to control the speed or power output of the steam turbine within the limits. The speed/load changer provided shall be capable of adjusting the speed of the turbo set to any value in the range of 94% to 106% of rated speed for manual/auto synchronisation of the generator with the bus. It shall be capable of varying the load on the machine from no load to full load.

For remote control, suitable motor drive shall be provided. Indication of the speed/load changer position shall be provided on the OWS and console panel insert.

The governing system shall be equipped with a load limiting device capable of being operated both locally as well as remotely from unit control room for the purpose of limiting the amount of opening of the governor controlled valves to set the load at a pre-determined limit, while the turbine is in operation. A remote position indicator shall be provided on the console panel insert for indication of the setting of the load limit. Contacts shall also be provided on the load limiter for signaling load limited operation in unit control room.



(ii) **Turbine Stress Control System (TSCS)**

Bidder shall provide a proven turbine stress control system which will work in conjunction with turbine governing system and ATRS. The system shall be complete including measuring transducers for generator load, processing modules, microprocessor based controllers for stress calculations and turbine life calculations etc., dedicated colour TFT monitor, recorders, etc. TSCS shall meet the following functional requirements

- (a) Continuous on-line monitoring of thermal stress levels in all critical parts of the turbine such as main stop valves, control valves, HP casing, HP shaft and IP shaft etc.
- (b) Continuous on line computation of stress margins available for the above mentioned critical components of the turbine during various regimes of operation i.e. run-up, synchronisation, loading, load maneuvering, normal operation, run backs, unloading, shut-down etc.
- (c) Computation of the limits of speed and load changes allowable at any particular instant before synchronisation and after synchronisation respectively. The system shall be designed to inhibit further operation like speed/steam temperature raising or lowering wherever upper/lower temperature margins are not available (during periods prior to synchronisation) and load/steam temperature raising or lowering whenever upper/lower load/temperature margins are not available (after synchronization) within allowable limits.
- (d) Carry out a fatigue analysis for all affected components of the turbine and also to compute the percentage service life consumption of the turbine.
- (e) Display the stress margins etc. on a separate dedicated colour VDU/Printer as well as on OWS for operator guidance and storage of necessary data such as percentage service life consumption etc.
- (f) Store long term data & carry out residual life analysis.

(iii) **BFP Turbine Electro hydraulic Governing System**

- a) The drive turbine speed shall be controlled by electro - hydraulic governor, stable and satisfactory speed control over full speed range from 0% to 100%. The electro-hydraulic governing system hardware shall be microprocessor based, with hot back up.
- b) When the governing system is in auto mode, it will receive speed demand signal from FW control loop and in manual mode shall be fed either from TFT of OWS or through auto/manual stations. The actual speed of the turbine should be measured by three independent speed sensors and three independent speed measurement channels. These three signals shall be fed to the selection circuit which will choose the median value. The speed controller output shall be fed to the valve lift controller. The output of the valve lift



controller shall be fed to the electro-hydraulic converter which will vary the position of the control valve. The electro-hydraulic controller shall be designed such that the transfer between different steam sources should be bumpless.

The electro-hydraulic control system to be provided by the bidder shall be of proven design, whose configuration and hardware implementation should have been employed in at least six(6) turbine driven pumps of equivalent capacity which are in operation for not less than two(2) years.

- c) A 220 V split-series field, reversible, totally enclosed DC motor along with an electronic controller, shall be provided for remote speed changing operation.

(iv) **HP&LP Bypass System**

a) **LP bypass control system**

The LP Bypass control system shall consist of steam pressure control loop and steam temperature control loop. The LP bypass control shall be implemented through a set of redundant controller modules, I/O modules etc. The LP bypass control shall suitably interface with other TG control like HP bypass, EHG etc. Further, condenser exhaust hood spray valve shall be interlocked to open whenever LP bypass comes into operation.

b) **HP bypass control system**

The system shall consist of steam pressure control loop & steam temperature control loop. HP bypass system shall be implemented through a set of redundant controller modules, I/O modules etc. The system shall be supplied with redundant primary sensor and suitable interface with other TG - C&I controls like LP bypass, EHG etc.

(v) **Automatic On Line Turbine Testing (ATT) System**

The bidder shall provide ATT system for on load testing of turbine protective equipment automatically in a sequential manner without disturbing normal operation and keeping all protective functions operative during the test. The ATT facility shall include but not be limited to the following.

- a) Opening and closing of emergency stop and control valves, reheat stop and interceptor valve.
- b) Over-speed trip
- c) Low vacuum trip
- d) Electrical remote trip.

ATT mentioned at item b), c) & d) above shall be possible to be carried out on 100% load.



6.2.4.7 **Other SG - C&I Functions**

The SG control functions shall also consist of secondary air damper control, soot blower control, auxiliary PRDS etc. in addition to the burner Management system and shall meet the requirements of measurements system, binary and analog control system as described above

6.2.4.8 **Other TG -C&I Functions**

The TG control functions shall also, consist of turbine generator control system like seal oil, primary water, hydrogen system etc. and TDBFP interlock & protection and shall meet the requirements of measurements system, binary and analog control system as described above.

6.2.5 **Man-Machine Interface System and Plant Information System (MMIPIS) Requirements**

- 6.2.5.1 i) Man-Machine Interface system shall be designed and engineered for safe, efficient, reliable and convenient operation. MMIPIS shall employ high-performance, non-proprietary architecture to ensure fast access and response time and compatibility with other system. MMIPIS shall be used primarily for the following functions :
- (a) As operator interface for control operation of the plant or accepting data from and issuing commands to SG -C&I, TG-C&I and BOP- C&I systems etc.
 - (b) To perform plant supervisory, monitoring and information functions
- ii) The plant data pertaining to one unit shall be available in the MMIPIS of the respective unit. Data from common system shall be available in the MMIPIS of both units.

6.2.5.2 **Operator Interface to the Control System**

- i) The operator interface of the MMIPIS shall consist of colour TFTs/ KBDs of OWS, colour ink-jet printers, colour plotter etc. Each OWS shall include one TFT, one keyboard and touch screen or mouse for ease of operation. The TFT operation shall employ powerful menu-driven and window supported input facilities for operational ease and comfort.

The following functions shall be provided as a minimum:

- a) Each keyboard set shall comprise of ASCII/ Numeric keyboard, function keyboard, control keyboard, cursor control keyboard etc.
- b) All OWS of the MMIPIS shall be fully interchangeable i.e. all operator functions including (for quick access to displays & other operator functions)



control, monitoring and operation of any plant area on drive shall be possible from any of the OWS at any point of time without the necessity of any action like downloading of additional files. Each OWS shall be able to access all control information related data under all operating conditions including a single processor/computer failure in the MMIPIS. Further, simultaneous operation of at least two drives of control system shall be possible from a single display without calling additional displays for multiple drive operation.

- c) No single failure in MMIPIS shall lead to non availability of more than one OWS and two printers. In such an event i.e., single failure leading to non availability of any OWS, it shall be possible to operate the entire plant under all regimes of operation including emergency conditions from each of the other available OWS.
 - d) Operator functions, displays, structure of the keyboard assembly and key assignment shall be finalised during detailed engineering. Further, all frequently called important functions including major control loop display shall be assigned to dedicated function keys for the convenience of the operator.
- ii) The operator functions for control on each OWS shall as a minimum include control system operation, alarm acknowledge, call control displays, demand/printout of various displays, logs, summaries etc.

The display selection process shall be optimised so that the desired display can be selected with the barest minimum number of key strokes / steps by the operator.

The control related displays on the TFT shall as a minimum include mimic displays, overview displays, area displays, individual loop/drive display, closed loop control displays, open loop control displays etc.

6.2.5.3 **Plant Supervisory, Monitoring and Information Functions of MMIPIS**

The MMIPIS shall be designed as an on-line system which shall process, display and store information to provide the operator, either automatically or on demand, the relevant information as indicated in subsequent clauses. The following minimum functions shall be performed by MMIPIS:

- i) **Calculations**
 - a) Basic calculations

All the algebraic/logical calculations related to analog points (e.g., sum/difference/average/integration, etc.), digital point (e.g., AND/OR/COMPARE. etc.), transformations, flow calculations, time projection or rate of change calculations, frequency etc. shall be provided. All the calculated values of the plant shall be available in the database.



b) Performance calculations:

The performance calculations shall use high level language calculations shall be made using floating point arithmetic. These equations shall be changeable on-line at the job site. An extensive set of steam property subroutines based on 1967 ASME steam tables shall be included in the system. The results of these calculations shall be available through data base for appropriate logs and operator displays. The calculation shall be carried out at 30% unit load or higher. The calculation frequency shall be selectable at site from 10 minutes to 1 hour, with a step of 10 minutes.

The performance calculations shall be broadly subdivided into two classes:

Class I : Equipment protection calculations

Class II : Plant/equipment efficiency calculation.

The Class I calculations are generally for the purpose of detecting and alarming unit malfunctions. These shall include cold reheat steam approach to saturation temp, superheater spray outlet approach to saturation temp., turbine steam-metal temp. differences, turbine metal temp. rates of change, feedwater heater terminal temp. difference, feedwater heater drain cooler approach, excess air deviation from standard, feed water heater temp. deviation from standard, drum water saturation temp. rate of change, metal temp. difference for SH 'Y' and RH 'Y' piece etc.

The Class-II performance calculations shall be performed to determine the performance of individual items of equipment and the overall unit. The periodicity of these calculation shall be selectable from 10 minutes to 60 minutes in increments of 10 minutes. These shall include calculations for boiler efficiency, gross turbine generator heat rate, gross unit heat rate, net unit heat rate, operating hours, plant load/availability factors, HP,IP,LP turbine enthalpy drop efficiency, performance of condenser, deaerator, economizer, airheater performance, unit availability calculations, merit order rating, deviation from expected values for each calculation shall also be computed.

c) Other Calculations

Variable alarm limit calculations, heat rate deviations and revenue calculations, frequency excursion time integration etc. shall also be provided.

ii) **Alarm monitoring and reporting**

The system shall display history of alarms in chronological order of occurrence on any of the OWS. The MMIPIS shall have the capability to store a minimum of 1000 alarms each with paging features allowing the operator to view any page. The OWS keyboard shall have all alarm functions and related function keys like alarm acknowledge, reset, paging, summaries etc. Other design features like prioritisation, set point/dead band adjustments, alarm report format etc., shall be as finalised during detailed engineering.



iii) **Displays**

Various displays on the TFTs shall as a minimum include P&ID displays or mimic, bar chart displays, X-Y & X-T plot (trend) displays, operator guidance message displays, group displays, plant start-up/shutdown message displays, generator capability curves, heat rate deviation displays, system status displays etc. Number of displays and the exact functionality shall be on as required basis and as finalised during detailed engineering.

Other types of displays as applicable for convenience of operation shall be provided by Bidder. However, the minimum quantity of major types of displays shall be as follows:

a)	Control displays (group/ sub-group/ sequence/loop)	500
b)	P&ID/ mimic display	100
c)	Bar chart	100
d)	X-Y/ X-T Plot	100
e)	Operator guidance message	100
f)	Plant starting/ shutdown guidance message	100
g)	Other misc. displays	25
h)	System status & other diagnostic displays on as required basis.	

The system shall have adequate storage capacity for storing the last 72 hours of data at scan rate for a minimum 500 points (operator selectable) for use in trend displays.

iv) **Logs/Summaries**

The system shall generate three basic types of reports/logs i.e., event activated, time activated and operator demand log & summaries. The log format and point assignment for each logs/ report and other design features shall be as finalised during detailed engineering. The system shall have the facility for viewing of time activated and operator demand logs/summaries on the TFT(s).

- (a) Event activated logs shall as a minimum include alarm log, trip analysis log, start-up - shutdown logs (Boiler start-up log, turbine run-up log, turbine shutdown analysis log/ turbine recall log) & control related logs.

The trip analysis log shall record a minimum of 30 pre-trip and 30 post-trip readings for the pre-defined parameters but not less than 250 points, sub-divided in to 25 groups. The data collection rate shall be variable, i.e. faster near the trip point and gradually slower with time. The exact details shall as finalised during detailed engineering.

The system shall be capable of generating and printing SG & TG start-up and shutdown logs.



- (b) Time activated logs shall as a minimum include shift log and daily logs. Each of these shall provide hourly record of a minimum 225 points sub divided into 15 groups.
- (c) Operator demand logs shall include, as a minimum, trend log, maintenance data log, summary log, performance logs and some special logs as decided during detailed engineering stage.

The system shall be capable of generating and printing trend log for a minimum of 80 groups of 15 points each.

Maintenance data log shall provide schedule of preventive maintenance and routine equipments inspection.

- (d) Various summaries shall include off scan summary, constants summary, point quality summary, substituted values summary, peripheral status summary etc.
- (e) The assignment of logs to any of the printers shall be possible from MMIPIS TFTs/ keyboards and programmer station.

v) **Log Generation Utility**

The bidder shall offer a log generation utility to generate a log/report having following facilities as a minimum.

- (a) Define format of the log like header information, time, date etc.
- (b) Selection of any point (scanned and calculated) from the data base and assign it to a log group.
- (c) Selection of log data collection process initiating event, collection intervals (1, 2, 3, 5, 10, 30, & 60 minutes) for each point of a particular log group.

Facility shall also be provided for selection of 100 points at a collection intervals of 1, 2, 3, 5, 10, 20, 30 seconds.

- (d) Assignment of log printout initiation on event or time including, selection of the printing interval for particular log group and time of printing. (For time initiated logs)
- (e) Assignment of no. of samples to be collected for each point.
- (f) Select points for which minimum, maximum accumulation over a selected period, average, etc., values can be printed. Also facility shall be provided to tag the time at which the parameter passed through maximum/minimum.

It shall be possible to define 100 log groups of 15 points each. Any log group can have any point from the database. One log shall include at the maximum 10 such groups.



(vi) **Historical Storage and Retrieval system (HSRS)**

The HSRS shall collect, store and process system data form MMIPIS data base. The data shall be saved online on hard disk and automatically transferred to erasable dual Magneto-optical disk (removable type) once in every 24 hours periodically for long term storage. Provision shall be made to notify the operator when optical disk is certain percentage full. The disk capacity shall be sufficient to store at least seven days data.

The data to be stored in the above system shall include alarm and event list, periodic plant data, selected logs/reports such as event activated logs, sequence event log, trip analysis log, start-up log etc. The data/information to be stored and frequency of storage and retrieval shall be as finalised during detailed engineering.

The system shall provide operator function to retrieve the data from historical storage. The operator shall be able to retrieve the selected data on either colour TFT or printer and suitable index files/directories shall be provided to facilitate the same.

In addition to the HSRS, the system shall also have facility to store and retrieve important plant data for a very long duration (plant life) on Magneto-optical disk.

A PC alongwith a laser printer shall be provided for this purpose. This PC shall be connected with the system bus, on which all the data can be accessed.

vii) **Quality Tag**

- a) The system shall identify and tag the quality of all data (scanned and calculated points) in a way that makes all users (control, calculations, logs, displays, etc.) aware of its quality. Quality of data other than 'good' shall be clearly identified in all printouts and displays by appending quality character to the value/status of point. The quality tagging shall include good, bad, substitute, doubtful, suspect, etc.
- b) DDCMIS shall provide fault alarm analysis guiding the operator to the most likely cause of fault. The alarm system shall be designed in such a manner that main auxiliaries tripping can be traced to the originating cause.
- c) Trend alarms shall be provided in DDCMIS for slowly varying process parameters, so that appropriate corrective actions are taken in time. These alarms shall be suitably provided in OWS, which will be decided during detailed engineering stage.
- d) An integrated unit startup system shall be implemented in DDCMIS incorporating all operational curves for SG, TG and auxiliaries. This shall guide the operator to take appropriate actions at appropriate time to bring the rated parameters safely within the specified time.



6.2.5.4 MMIPIS Hardware

- i) The MMIPIS as specified shall be based on latest state of the art workstations and servers and technology suitable for industrial application and power plant environment. Two possible alternatives for MMIPIS can be offered by the bidder. For alternative-I, the no. of redundant servers shall be as required to achieve the processing capability to meet all the functional requirements of this specification. For alternative-II, the workstations other than OWS shall be configured in such a way that loss of one workstation does not result in loss of any function.

The actual size of the main and bulk memory shall be sufficient to meet the functional and parametric requirements as specified with 25% additional working memory and 50% additional bulk memory over and above the memory capacity required for system implementation. The exact system configuration and sizing shall be as approved by Purchaser.

- ii) The workstation/servers employed for MMIPIS implementation shall be based on industry standard hardware and software which will ensure easy connectivity with other systems and portability of purchaser developed and third party software. These will be 32 bit/ 64 bit machines. Each workstation/server shall be provided with an UPS each for 60 min. back-up with output messaging facility for loss of input power.
- iii) Redundant sets of communication controllers shall be provided to handle all the communication between the MMIPIS and redundant system bus and to ensure specified system response time and parametric requirements. Each communication controller shall have message checking facility.
- iv) Power fail auto restart (PFAR) facility with automatic time update shall be provided.
- v) All the peripherals shall be as approved by purchaser during detailed engineering. The LAN to be provided under MMIPIS shall support TCP/IP protocol (ethernet connectivity) and shall have data communication speed of minimum 100 MBPS. All network components of LAN and servers/workstations shall be compatible to the LAN, without degrading its performance. It shall be ensured that failure of network component (s), shall in no way affect individual unit's operation monitoring & control in any way.
- vi) Servers/ workstations shall be as per latest configuration available and subject to approval of the purchaser during detailed engineering.

6.2.6 Program Development/ Modification, System Maintenance and Documentation Facility

6.2.6.1 Bidder shall provide programming facilities/systems as a minimum for control system and MMIPIS.

- i) The programming tools shall have inbuilt safety features which will protect the system against inadvertent and unauthorised use of these tools. Necessary hard key locks and software locks, etc. shall be provided for this.



- ii) The system shall also have facility to permit the programmer to add test information at the beginning and end of each program, wherein programmer will list out his name, time, date, the change which has been made, name of the person who has authorized the change, etc.

6.2.6.2 **Control system structuring/configuration/tuning facilities**

- i) Structuring, configuring and tuning facilities shall be provided for structuring, modification, storing, loading, testing, tuning, monitoring, etc. of all the microprocessor based controllers of the control system. The configuration and tuning unit shall be hooked up with the system bus. In case different hardware is employed for different parts of control systems and it is not possible to provide structuring/ configuration and tuning of these from the same station, bidder shall provide necessary number of stations for the purpose.
- ii) It shall be possible to configure the system with ease without any special knowledge of programming or high level languages. Control strategy shall be implemented using familiar and conventional automation function blocks (software implemented). Whenever any change in configuration is done, it shall be recorded and modified configurations shall be available for printing and documentation and shall be stored in non-volatile memory. All the system configuration, tuning/ fixed parameters shall be documented and printed in form of function diagrams and lists respectively.

On-line tuning of the control loops shall be possible without causing any disturbance in the execution of the control loops. Provision to store and retrieve on immediate and long term basis the system configuration, data base etc. on some device such as floppy disk shall be included. Facility shall be provided to reload/down-load the system or controller module from the already stored data, on-line.

6.2.6.3 **MMIPIS program development/modification and system maintenance facilities**

Standalone online system shall be provided for programme development/modification to achieve various functions including development, modification and testing of software of MMIPIS, generation and modification of graphics, logs, HSRS functions in an interactive manner, MMIPIS database modification/creations, downloading the software with associated data base from the console and other features necessary for system maintenance. All operator functions shall also be available on MMIPIS programmer station. Also facility shall be provided to print system fault as detected by the online self diagnostic routine.

6.2.6.4 **System Documentation Facility**

- i) The system shall have the facility to generate the associated documentation for both the control system & MMIPIS. The bidder shall furnish detailed information about system documentation facilities in his offered system along with the bid. The document, to be generated by the system shall include



P&ID drawings, control loop drawings, sequence drawings, signal distribution list/drawings, system interconnection drawings, cabinets general arrangement drawings, measurement list, drive schedule, alarm schedule, system hardware and functional configuration drawings for displays, logs, trends, graphics etc. The system shall also include all required software and hardware tools for creating, modifying and printing CAD drawings to achieve paperless documentation for DDCMIS.

- ii) To realise all of the functions mentioned above, the bidder shall provide standalone stations for configuration & tuning functions of control system and MMIPIS programming, hardware of which shall be separate from the hardware of the respective system and connected to system bus. The bidder shall provide 2 nos. of programmer stations for control system and 1 no. programmer station for MMIPIS. Each of the programmer station shall also have a colour inkjet printer. The hardware for system documentation facility may be a part of either configuration and tuning unit for control system or MMIPIS programmer station if all the functions specified above can be achieved in these programmer stations. Otherwise a separate workstation and a colour inkjet printer shall be provided for documentation facility with necessary software. The hardware of workstation shall be same as that of OWS.

6.2.7 Data Communication System (DCS)

6.2.7.1 The DCS shall include a redundant main system bus and local system buses for major subsystems with hot back-up and other applicable bus systems like cubicle bus, local bus, I/O bus etc except back plane which can be non-redundant. The DCS shall have the following minimum features :

- i) Redundant communication controllers shall be provided to handle the communication between each functional group of controllers of control system and the system bus. The design shall be such as to minimise interruption of signals. It shall ensure that a single failure anywhere in the media shall cause no more than a single message to be disrupted and that message shall automatically be retransmitted. Any failure or physical removal of any station/module connected to the system bus shall not result in loss of any communication function to and from any other station/module.
- ii) If the system bus requires a master bus controller philosophy, it shall employ redundant master bus controller with automatic switchover facility.
- iii) Built-in diagnostics shall be provided for easy fault detection. Communication error detection and correction facility shall be provided at all levels of communication. Failure of one bus and changeover to the standby system bus shall be automatic and completely bumpless and the same shall be suitably alarmed and logged.
- iv) The design and installation of the system bus shall take care of the environmental conditions and hazardous area classification as applicable to similar services.



- v) Data transmitting speed shall be sufficient to meet the responses of the system in terms of displays, control etc. plus 50% spare capacity shall be available for future expansion.
- vi) Passive coaxial cables or fibre optic cables shall be employed for system bus.
- vii) The redundant buses shall be physically separate and shall be routed separately.
- viii) The Bidder shall furnish details regarding the communication system like communication protocol, bus utilisation calculations etc.
- ix) In case of any distance or other limitation in the DCS, bidder will provide suitable repeaters, MODEMS, amplifiers, special type of cables like optical fibres as required to make the DCS fully operational.

6.2.7.2 **Station LAN**

The servers/ethernet LAN of the each unit shall be connected to a station wide ethernet Wide Area Network (LAN). Connections for PCs at various plant locations and PLC/PC based systems provided both by bidder as well as by purchaser, shall be connected to this station wide ethernet LAN through TCP/IP protocol. The station head/O&M head & shift in-charge stations shall be located in this LAN to monitor data of all units as well as of the common plant location and off-site plants.

A server shall be provided for this station wide LAN. All networking functions of LAN, calculation including merit order calculation shall be performed in this server.

6.2.8 **Sequence of Events Recording/ Annunciation Functions**

6.2.8.1 **SOE Function**

- i) The system shall monitor SOE inputs with a resolution of one millisecond at all times for all SOE inputs including spare inputs. That is, all SOE points entering status change shall be reported and time tagged within 1 (one) millisecond of their occurrence. Input card shall be equipped with digital filters with filter delay of minimum 4ms (identical for all points) to eliminate contact bounce such that field contact which is changing state must remain in the new state for successive 4 ms to be reported as one event. The start of data collection for SOE report shall be reported to OWS within 1 sec of SOE data collection initiation. The system shall also have provision of rejection of chattering inputs.
- ii) The system shall also include provision for historical storage and retrieval of SOE reports for 3 months period.
- iii) The SOE report collection shall begin on occurrence of change of status of any SOE point and shall be printed after an operator selectable time interval of 1 to 3 min. or 100 status changes have taken place after the first event.



Adequate memory to accommodate 6 (six) SOE reports i.e., two buffers of 100 status changes each shall be provided. Seventh SOE report shall overlap the first SOE report memory and so on.

- iv) The SOE reports shall also include a list of major equipment trip in chronological order and include the points which initiated SOE collection.

6.2.8.2 Annunciation system Function

- i) The annunciation system shall be implemented as an inbuilt function of the DDCMIS. The field contacts shall be acquired through DDCMIS only. The annunciation sequence logic shall be implemented as a part of the DDCMIS controllers. The annunciation window lamps mounted on unit control panel shall be driven through contact output modules of the control system of DDCMIS. In case, the annunciation sequence logic is not performed within the controllers for MFT (BMS), TPS etc., then these signals can be transmitted through some other controller through bus and processed therein.

However, the annunciation system shall have the facility of driving independent lamp box in the event of failure of MMIPIS or system bus in case the annunciation system is affected due to the same.

6.2.9 Master & Slave Clock System

- i) The bidder shall provide a date insensitive master and slave clock system with adequate number of output signals to provide uniform timing throughout the various plant facilities supplied by bidder as well as those not in bidder's scope. The system shall be complete with receiving antennae (for receiving time from satellite & radio signal), receiver and associated electronics, redundant master clocks, slave clocks, interconnecting cables, cubicles, power supplies & any other accessories. However, a provision shall be kept for synchronisation of the master clock with other source as decided during detailed engineering.
- ii) The master clock shall drive the slave display units. It shall be ensured that loss of any slave display unit does not affect the display of any other slave unit. The MMIPIS, shall be synchronised with the master clock once in every hour. The switchyard event recorder and other plant PLCs shall be synchronised with the master clock once every minute.
- iii) The master clock shall be located in the control room and shall have facility for automatic synchronising with external radio/satellite signals.
- iv) The Bidder shall provide a minimum 25 number of slave clocks which shall be located at the various plant facilities as finalised during detailed engineering stage.

6.2.10 Power Supply & Grounding

- i) Bidder shall provide totally reliable & quality power supply for total DDCMIS.



- ii) All panels, desks, cabinets shall be provided with a continuous bare copper ground bus. The ground bus shall be bolted/ welded to the panel structure and shall efficiently ground the entire structure. All individual cabinet grounds shall be connected to separate earthing riser to be provided for C&I system signal grounding. The grounding requirements of various parts of the C&I system shall be properly co-ordinated by the Bidder with design of plant earthing system. The exact grounding scheme shall be as finalized during detailed engineering.

6.2.11 System Software Requirements

- i) The bidder shall provide all software required by the system for meeting the intent and functional/ parametric requirements of the specification.
- ii) The system shall have user oriented programming language & graphic user interface.
- iii) All system related software including real time operating system, file management software, screen editor, database management software, on line diagnostics/debug software, peripheral drivers software and high level language compilers shall be furnished.
- iv) All application software for control system functioning like input scanning, acquisition, conditioning processing & control alongwith communication among various control system functional blocks, MMIPIS and system bus, MMIPIS software for operator interface of monitors, displays, trends, curves, bar charts etc., performance calculations (with steam properties routines utilities) historical storage and retrieval utility, sequence of events recording system functions shall be provided.
- v) The bidder shall provide software locks and passwords to purchaser/ project manager at site for all operating & application software in order to prevent unauthorised access so that only purchaser's authorised representatives is able to do modifications at site.

6.2.12 System Documentation

The bidder shall furnish detailed system and equipment documentation. It shall include detailed system and components description covering the installation, operation, care and maintenance of all system components. All final system documentation for DDCMIS hardware and related software shall be furnished. The same shall be complete, accurate and fully representative of the supplied system and its elements. All documentation/catalogues etc., shall be furnished in English language. In addition to the hard copies, CD ROM based documentation system shall also be provided. The same should be compatible to the on-line document generation facility indicated elsewhere in the specification.



6.2.12.1 Hardware documentation

- i) Detailed technical literature, reference manuals, user's guide/manuals for the complete hardware like control system hardware, MMIPIS hardware, I/O hardware, bulk memory units, peripherals and their controllers, communication hardware including controllers, man-machine interfaces programmers unit, power supply modules etc., shall be furnished by the bidder.
- ii) Operation and Maintenance manual

6.2.12.2 Software documentation and software listings

- i) All technical manuals, reference manuals, user's guide etc., in English required for modification/ editing/ addition/ deletion of features in the software of the DDCMIS shall be furnished. The bidder shall furnish a comprehensive list of all system/application software documentation after system finalisation for Purchaser's review and approval.
- ii) The software listings shall be submitted by the bidder for source code of application software and all special-to-project data files

6.2.13 Training

- i) Further to the relevant clauses regarding training specified elsewhere, Bidder's experienced personnel engineers shall also provide training courses on offered DDCMIS to purchaser's engineers in the following areas:
 - 1. Operator training
 - 2. Hardware maintenance training
 - 3. Software training
 - 4. Any other specialised training as required for system operation and maintenance
- ii) The maintenance training shall include lectures and hands on experience on a similar type of equipment/system at manufacturer's works and recently commissioned operating plant and/or training simulator. The purchaser shall require training of hardware and software engineers. The details of hardware and software training shall be finalised during detailed engineering and shall be subject to purchaser's approval.

6.2.14 Warranty

- i) The bidder shall provide an unlimited warranty on all equipment and software for one year after the start of the warranty period, i.e. after satisfactory completion of initial operations. This warranty shall include repair, replacement or correction of identified software or hardware discrepancies at no cost.



- ii) No repairs/replacement shall normally be carried out by the purchaser when the plant is under the supervision of bidder's supervisory engineers. If in the event of any emergency, in the judgment of the purchaser, delay would cause serious loss or damage, repairs may be made by the purchaser or a third party chosen by the purchaser without advance notice to the bidder and the cost of such work shall be paid by the bidder.
- iii) In case of any hardware failure which hampers normal operation, the bidder during the warranty period must provide on-site technical expertise to repair/rectify the problem within a week and if any component is not available at site, the bidder must arrange to supply these components at site within another 48 hours. If a software problem is identified, this problem shall be corrected within one week.
- iv) After six months of DDCMIS operation, the bidder shall provide the list of parts and expandables utilized for the period. The same information will be provided at the conclusion of the warranty.
- v) The bidder shall depute and/or station additional specialist to rectify the problem to ensure 99.7% availability of system. The availability of system shall be calculated as specified elsewhere.

6.2.15 Performance Requirement of the DDCMIS

- i) The DDCMIS shall permit the performance of the following dynamic load tests while maintaining safe furnace conditions, major process parameters and without endangering other equipment. All tests will be performed with the system in automatic mode :
 - a) Drop 50 percent of maximum load capability from approximately full load at a rate of 10 percent per minute.
 - b) Drop load from full rated output to the lowest runback limit, at a rate corresponding to the fastest run back rate
 - c) Pick up 50 percent of the maximum load capability from approximately 50 percent load at a rate of 10 percent per minute.

During transient conditions causing deviation of process variables, the control system furnished under the specification shall not permit deviations which exceed those permitted by the manufacturers of the controlled process equipment, for load changes as indicated above. The exact parameters to be monitored for this test are given in the following table The control loops shall perform to return the controlled variable to the set point in a stable manner without cycling in the shortest possible time and without any loop interactions or cycling of generation when generation matches unit load demand.



Performance Requirements for Closed Loop Control System (Table 6.2.1)

Sl. No.	Load/Rate of load change (% of MCR per min.)	Maximum Deviation of Parameters from Set Point					
		Throttle pressure deviation (Kg/cm ²)	Flue gas oxygen deviation (% O ₂)	Furnace pressure deviation (mmwcl)	S.H. steam temperature deviation (Deg. C)	R.H. steam temperature deviation (Deg. C)	Drum level mm
A.	Steady state condition						
	1. 90% to 100%	± 2.0	± 0.4	± 8.0	± 5.0	± 5.0	± 15.0
	2. 60%	± 2.0	± 0.4	± 8.0	± 5.0	± 5.0	± 15.0
B.	Ramp test (change for max. duration of five minutes)						
	1. ± 3%	± 3.0	± 0.6/- 0.4	± 12.0	± 8.0	± 8.0	± 25.0
	2. ± 5%	± 3.0	± 0.8/- 0.4	± 12.0	± 10.0	± 10.0	± 30.0
	3. ± 10%	± 4.0	± 1.0/- 0.5	± 15.0	± 15.0	± 15.0	± 50.0
C.	Step load changes						
	1. From 100% to 80% at the rate of 10% per minute	± 5.0	± 1.5/- 0.5	± 20.0	± 15.0	± 15.0	± 50.0

Notes:

- a. Sufficient time shall be allowed as setting period between conducting the tests.
 - b. Plant operating condition, i.e. main equipment status, availability of auxiliaries, operational and equipment constraints, which can influence the test, shall also be recorded.
 - c. Control system shall be running in the coordinated master control (CMC) mode i.e boiler master, fuel flow, air flow, feed water and turbine load control shall be in automatic mode. Load set point, maximum and minimum load set point, rate of raise / lower of load shall be set through the TFT, keyboard/conventional console.
- ii) The bidder shall also guarantee that the control system provided by him will be responsive and stable and will maintain the deviation of controlled variables from set point within the limits specified so that the equipment



being controlled will operate as specified over the range required. The controls shall operate automatically, with no assistance from the operator. The controller shall successfully demonstrate the performance of Closed Loop Control Systems before acceptance and taking over of this system by the owner.

- iii) The following parametric tests shall also be conducted under worst case loading conditions
- a) For control system
CPU loading, cycle time/controller reaction time and memory spare capacity
 - b) For MMIPIS
CPU loading, spare duty cycle, spare memory capacity
 - c) Spare duty cycle for system bus
 - d) Various display response time
 - e) System accuracy
 - f) TFT update time
- iv) For the parametric test, the following requirements shall be met
- a) Processor spare duty cycle (free time)
Under worst case loading of MMIPIS and system bus each MMIPIS processor shall have 40% free time when measured over any two second period and 50% free time when measured over any one minute period.

Under worst case loading conditions of control system control system processor shall have 20% free time when measured over any one minute period.
 - b) System bus spare duty cycle (free time).
The Bidder shall furnish all necessary data to fully satisfy the owner that the processor spare duty cycle figures quoted by the Bidder are realistic and based on configuration and computation capability of the offered system and these shall be actually achieved in the fully implemented system as commissioned at project site.

The system bus shall have min. 50% free time during the worst case loading conditions of control system, MMIPIS and the system bus, measured over any 2 seconds interval.



c) Display response time

The system shall acknowledge all operator requests in one of the following manners within one second of pressing of the last button:

Commencement of the requested display

OR

Acknowledgment of operator request in a suitable manner.

The display response time as defined above, under the worst case loading conditions shall not be worse than the following:

All control related displays	1 sec
Point details display (single point)	1-2 secs
Bar chart display (20 points, current data)	1-2 secs.
Operator guide / plant start-up guide message display (full screen of alphanumeric information and a maximum of ten numbers of dynamic data items)	1-2 secs.
Plant mimic display of fair complexity with a minimum of 120 numbers of dynamic data items e.g., values, macros, line segment, etc.	2-3 secs.
Group review display (current values of twenty points)	2-3 secs.
X-Y plot display (2 X-Y- plots and a single display requiring both historical as well as current data)	3-4 secs.
X-T plot display (trend of 6 analog points and a single display requiring both historical as well as current data)	3-4 secs.
Plant summary display (e.g., bad point summary, limit check removed point summary. Assume the whole data base search is required and the summary display contains ten points only).	3-4 secs.



The response time for screen update after the execution of the control command from the time the command is issued (for example command to start a motor to the time the screen is updated) shall be two seconds (excluding the drive actuation time).

d) System accuracy requirements

The overall system accuracy from signal input terminals to output presentation on TFT display and printers for the least accurate input range and maximum scan rate shall be not worse than +/- 0.2% of full scale of the process range.

e) TFT updated rates

All TFT displays shall be updated at least every two seconds.

6.2.16 Large Video Screen (LVS)

Large video screens, complete with projectors, screens, control units (graphical generators) & associated accessories shall be supplied as per the following specifications.

- | | | |
|----|---------------------------|---|
| 1. | Size (diagonal) | 80 inch |
| 2. | Type | LCD projection type with rear - screen configuration (other type proven technology e. g. that based on digital light processing shall also be acceptable subject to purchaser approval). |
| 3. | Resolution of each screen | 1280 x 1024 pixels |
| 4. | Configuration of LVS | Double tier with screens seamlessly combined with provision of expansion of one screen on each side. |
| 5. | Control unit | Same as operator work station without the TFT LCD monitor.

Facility of projecting a particular display on a selectable area of the screen upon activation of a predefined event shall be provided. |
| 6. | Video signal interface | Interfacing with video signals, to receive & project pictures from CCTV, purchaser's Live camera, VCP

Signal types : PAL, NTSC or SECAM in S-VHS/VHS |



No. of channels : 16

Remote unit for switching between video signal & HMI signal, selecting the video signal channel (live camera no./location typically) shall be provided.

- | | | |
|----|--|---|
| 7. | Illumination level | To be finalised during detailed engineering. |
| 8. | Degree of viewing in horizontal & vertical | To be finalised during detailed engineering. |
| 9. | Other features | |
| | a) | LVS shall be designed for continuous viewing (24 hours in a day) under normal room ambient lighting without any need to darken the room. Suitable darkening of the projection screen for light absorption shall be provided for this purpose. |
| | b) | Adjustment of the projections shall be performed. Suitable mounts on installation and all other components shall be adjusted in the factory and shall not require further adjustment at site. Maintenance work on the LVS shall be confined to easy replacement of the lamps and cleaning of the fans, which shall be performed in few minutes by the purchaser's staff without any special training. Suitable means (operating hours displays etc.) shall be provided to indicate the need of replacement of lamp. Power switch shall be provided for isolation during replacement of the lamps. |
| | c) | The LVS and its accessories shall be designed in such a way that the brightness in the centre of the screen and the edges of the screen is uniform and there is no perceivable difference in the quality of the picture on the centre and on the edges of the screen. If any extra hardware has to be provided for achieving the above feature, same shall be provided by the contractor at no extra cost. |
| | d) | The screen should be flicker free and there shall not be any screen burn in due to display of same information for a long time. |
| | e) | Auto brightness adjustment between each screen. |



10. The hardware/software of the control unit shall be such that the command execution time of any control command from the LVS shall be same or better than the execution time from the OWS. If during any stage of the contract, the command response times as stated in specifications are not achieved, the contractor shall upgrade the hardware/software of the control unit in order to achieve the same at no extra cost to the purchaser.
11. In the event of failure of LVS interfacing with SG & TG package, any of the other LVS shall be capable of being used in place of the failed LVS .The contractor shall provide a suitable network/switching facility for this purpose.

The exact arrangement of LVS shall be decided during detailed engineering.

Suitable facility shall be provided to the operator for transferring the screens, without any need of changing of hardware/wiring or software.

12. Master control unit shall be capable of projecting displays over a part of screen to multiple screens. Any communication of windows shall be possible. Facility for overlays shall be provided.



6.3 OTHER SG&TG RELATED CONTROL & INSTRUMENTATION SYSTEM/ EQUIPMENTS

6.3.1 Flame Monitoring System

- i) The purpose of the system is to detect the individual flame and to enhance the boiler/furnace safety, to avoid spurious and unwarranted trips and to increase operational reliability, availability and efficiency of the Steam Generator such that the consumption of fuel oil shall be reduced to optimal minimum.
- ii) Flame monitoring system shall be fail safe and easily maintainable which shall include flame detectors of proven design for the type of fuel, environmental condition and other conditions, of established reliability at all loads of the steam generator. It shall be designed to work under all adverse conditions such as wide variation in fuel/air input ratio, wide variation in fuel characteristics, variation in operating temperature, maximum temperature under interruption of cooling air supply. The system shall conform to NFPA recommendation and location of detectors as per NEC requirements.
- iii) Flame detectors shall be working on the dynamic and static properties of primary combustion zone of each type of fuel and flicker frequency of flame. It shall pick up only the flame to which it is assigned and shall not respond to the adjacent and background flame or other radiations generated in the furnace. The design shall also take into account the absorption by a coal shroud, recirculated dust or other deposition on the flame detector head. The complete system shall provide the discrimination between oil and coal flame. Intensity indicators for main flame shall be provided alongwith galvanically isolated 4-20 mA DC signals and hooked to DDCMIS.
- iv) The system should be easily maintainable and include automatic self test facility at regular interval.
- v) The bidder shall also provide a portable flame detector testing kit with built in stabiliser, capable of simulating both oil and coal flame, and testing of flame detector head unit at field. The testing kit shall also have facility for testing all type of electronic cards as being used in the flame monitoring system.
- vi) In case of tangentially fired boiler, the bidder shall arrange flame detectors in such a manner that coal flame detectors are available both above and below each coal burner and separate oil flame detectors are provided for each oil burner. In case bidder has discriminating type flame detectors capable of detecting and discriminating both oil and coal flame, with the help of a single scanner, the same can also be utilised for monitoring both oil and coal flame. For any other type of firing i.e. non-tangential type the flame detectors shall be provided for each coal and oil burner responding only to the flame of its associated burner.
- vii) Bidder shall furnish the details of the flame detector locations and justification for the same.



- viii) The Bidder shall demonstrate the complete performance of flame detectors in cold start up test and load condition test. In cold start up test, capability of detectors to detect oil flame under varying oil pressure shall be checked. In load test, the detector shall be able to detect when only oil is present, only coal is present and both coal and oil are present. It shall be ensured that the detectors are able to detect the proven flame at very low load with oil guns withdrawn. The above tests shall be performed for every coal and oil elevation.
- ix) Provision of scanner air for cooling the flame detectors by 100% redundant scanner air fans, one AC and other DC operated, shall be provided. The dampers associated with scanner air fans shall be pneumatically operated with DC solenoid valves.

6.3.2 Coal Feeders Control and Instrumentation

- i) Bidder shall provide a microprocessor based coal feeder C&I system. It is preferable to use the same family of hardware as that of DDCMIS for implementation.
- ii) Bidder shall provide a minimum of two independent speed sensors, pulser units and associated amplifiers, etc. for each of the coal feeders. Output from the speed sensors will be used to provide at least four number isolated 4-20 mA DC analog signals corresponding to coal flow rate in tons per hour and any other signals that may be required for the control of the coal feeder. In addition, one pulser unit shall also be provided with two pulse outputs-one for use in control system and the other for remote integrator.
- iii) Each coal feeder shall receive signals from DDCMIS for feeder speed control. The signal to be provided by DDCMIS shall be in the form of galvanically isolated 4-20 mA DC. All required power amplifier units/interface devices to accept this 4-20 mA signal shall be included.
- iv) All associated electronics like buffer amplifiers, frequency to current converters etc. shall be provided for each raw coal (RC) feeder with local and remote speed indicators and integrators. The speed sensors and pulser units shall be totally enclosed, fire, dust and weather proof, suitable for the service conditions.
- v) The control cabinet shall be provided with reset push buttons and individual lights to signal the individual internal trip conditions.
- vi) Each feeder shall be provided with a four position switch located at the feeder for remote off, local run (when there is no coal on conveyor) and calibration purpose.
- vii) If there is any electronic modules mounted local to the feeder body then these shall be suitable for operating in a non-air-conditioned area in a suitable enclosure to combat the effect of noise, vibration, entry of dust etc.



- viii) All necessary paddle switches and other detectors to monitor coal on belt, feeder discharge plugged etc. should be provided to ensure safe operation of the feeders.

6.3.3 Electromatic Safety Valves

The electromatic safety valve shall be an automatic, electrically actuated pressure relief valve. It shall be possible to set the value for one percent or less differential between opening and closing pressure. The electromatic safety valve shall be provided complete with all accessories like pressure measuring devices, controller units, local PB station, solenoid assembly, impulse piping etc. Provision shall also be kept to operate the electromatic relief valves from the DDCMIS TFT/KBD and miniature PB stations on the UCP, if applicable. The operation of the valve shall be accomplished by operator command or by means of pressure sensitive element which shall precisely and automatically relieve the pressures within very close limits.

6.3.4 Furnace Temperature Probes

Bidder shall provide two numbers of furnace temperature probes before platen superheater and/or before reheater regions and shall be electrically operated, fully retractable type. The furnace temperature probes shall be furnished with complete actuating mechanism and all the logics required for the actuating mechanism. The probe shall be provided with position transmitters, limit switch and indicator for remote indication. Each temperature probe shall have a duplex thermocouple suitable for the measurement range. Bidder shall furnish complete details of the temperature probe along with all the technical catalogues including the details of the actuating mechanism, position transmitters and limit switch which shall be subject to purchaser's approval. The logics for furnace temperature probes shall be implemented in the DDCMIS.

6.3.5 Acoustic Pyrometers

Acoustic pyrometers are to be provided to determine the average flue gas temperatures and complete flue gas temperature profile at furnace exit plane (for FEGT measurements) and at economiser outlet.

For each temperature measurement plan/section, a PC based system complete with all required software, comprising of minimum eight nos. of acoustic transreceivers, signal processor, interface unit, PC & colour Inkjet printer (common for one unit) shall be provided. The system shall be able to eliminate the varying high noise environment both in and out of an operating boiler

The transit time of each of the associated transmitters/receivers shall be transmitted to the central processing unit (to be located at CER) for storage and analysis through suitable interface device. A temperature profile shall then be determined and displayed by analysing the mean temperature across every transit section using deconvolution technique. The time interval to take a complete cycle of eight transceivers should be less than one minute.



The measuring range should be sufficient to cover the entire regime of boiler operation and shall not be less than 1900°C. The mean temperature and profile temperature accuracy shall be $\pm 2\%$, & $\pm 4\%$ of reading respectively or better. Full colour VDU display and colour printer output shall be provided. The system shall also provide 4-20mA DC output for SG -C&I and BOP-C&I part of DDCMIS.

The transducers shall not be placed directly in the hot gas stream. The system shall be of proven design and its performance must be proven using similar type of fuel. The components to be located at boiler area shall be able to withstand the stringent environmental condition expected at such locations with operating boiler.

6.3.6 Mill and Air Heater Fire Detection System

Adequate number of thermocouples type fire detection system for each mill and air heater shall be provided as a composite and complete units with all required signals and accessories with adequate redundancy.

The controls & protection required for the mill fire detection system shall be implemented in the SG-C&I and air heater fire detection system shall be implemented in the BOP -C&I, Part of DDCMIS using rate-of-rise algorithm taking care of manufacturer's recommendation.

6.3.7 Furnace and Flame Viewing System

- i) Bidder shall include in his proposal a furnace and flame viewing system. The flame cameras shall be suitable for direct online continuous viewing in the central control room of the coal and oil flame and condition of the furnace internals including slagging of the water walls and any other deterioration in the furnace condition. The nos. of such flame cameras to be included in the proposal shall be selected by the bidder appropriate to his boiler design subject to minimum of four (4) numbers.

The flame camera system will consist of the following facilities/ components as a minimum: -

- a) 19" High resolution color monitor.
- b) Facility for zooming and adjustment of iris from the monitor
- c) Proper cooling arrangement (preferably air) and protection against cooling medium failure.
- d) Weatherproof local control box for mounting of electronics.
- e) All necessary remote/ local programming tool.
- f) All interconnecting cable and termination device.
- g) Any other accessory to make the system completely operational.



- ii) The cameras and the total system shall be suitable for the furnace design as being offered by the main boiler vendor, the firing arrangement, the fuel being fired considering the ash content of worst coal. The cameras should be expected to withstand the temperature expected in the furnace of the offered boiler but shall not be less than 1600 deg C.
- iii) The viewing angle of the camera shall be commensurate with the furnace size, the camera location and the positioning of the burners. The system shall conform to PAL and number of TV lines shall be adequate for a clear image of the furnace.
- iv) The offered flame camera system shall have a record of trouble free performance of minimum one (1) year in a coal-fired boiler of size 500 MW or above where the firing arrangement is similar to the offered boiler.
- v) The system shall be capable of transmitting the image to the DDCMIS system where it should be possible to display the same on the monitors of operator workstation.

6.3.8 Electronic Remote Drum Level Monitoring System

Bidder shall provide electronic remote drum level monitoring system working on principle of difference in electrical conductivity between steam and water. The monitoring system shall meet the requirements as indicated below:

- i) Each end of the drum shall have independent pressure vessels with adequate no. of electrodes covering the entire range for indication for each end of drum. Further, independent and separate pressure vessels shall also be provided for each end of drum/vessels along with electrodes to provide validation for low low trip setting.
- ii) The sensing electrodes shall be placed in equal pitch. The maximum distance (gap) between two electrode shall be 50 mm and the electrodes shall be arranged in such a way that the last and the first electrode shall not be at any alarm or trip level. In any case, the number of electrodes shall not be less than 16 for indication and 8 for validation.
- iii) Both indication and validation systems shall be supplied with double isolation valves in water, steam, drain and vent lines with mechanical key interlock system, that is, the total number of key interlocks shall be 4 (four) nos. per boiler. The provision of key interlock system shall ensure a fool proof safety feature and the details of the same shall be brought out clearly in the offer.
- iv) The detector unit (if not located locally), logic units, 2x100% redundant power supply units/packs (to be located in control equipment room) shall be housed in separate and independent cubicles for pressure vessel on each side of the drum. The detector units, logic units etc. shall be independent for each pressure vessel.



- v) Indication shall be provided at field for both indication and validation system. Remote indication is to be provided for indication system at the unit control panel and firing floor.
- vi) Each cubicle shall be provided with 2x100% redundant power supply pack converters to be fed from two feeders of 24V DC or 240V AC UPS system. These two power supplies shall be internally fused and failure of one power supply shall not affect the performance of the system. Self monitoring facility to detect and alarm the loss of power supply shall be provided.
- vii) The pressure vessel shall be constructed in such a way that density level error between drum and pressure vessel shall not be more than 25 mm upto the design temperature and pressure of boiler drum. All vents, drains and isolation valves shall meet 1.5 times the max. design conditions.
- viii) Electrode assembly shall have blow out and leakage proof sealing arrangement. Field proven ceramic/zirconia probe with insulation suitable for design pressure and temperature are to be provided.
- ix) The system design shall be such that it shall ensure that failure of one probe circuit shall not affect another probe circuit and failure of any electrode will not hamper the system function and operation. Further, the entire system shall be of proven fail-safe design.
- x) The logic shall be such that the trip and alarm relay circuits shall be independent for each for low, low-low, high and high-high levels of drum. Monitoring of set time for trip generation and provision of setting time delay shall be available in the system. Trip logic shall be independent and separate from fault finding logic.
- xi) The system shall have fault diagnostic features such as process fault, system hardware fault, probe failure, circuit board failure, shorted wire etc. Further, the system shall be able to distinguish between a cable fault and an electrode fault.
- xii) The necessary relays and relay modules for the output contacts shall be of proven design and each contact shall be rated for 5A, 240V AC/0.25A 220V DC rating. All these contacts shall be SPDT type.
- xiii) The system shall be proven and approved by IBR, Factory mutual, USA or equivalent etc.

6.3.9 Turbine Supervisory System (TSS)

- i) The turbine supervisory equipment shall be complete including sensors, transmitters, converters, limit value monitors, measuring and amplifier modules, power supplies etc. with the required accessories including twisted and shielded instrumentation cables, compensating cables, junction boxes etc.
- ii) Following measurements shall be provided as minimum.



- (a) Shaft eccentricity detection.
 - (b) Absolute as well as relative shaft vibration measurement, of each bearing in both X & Y direction.
 - (c) Differential expansion of rotor and cylinder for HPT, IPT and LPT.
 - (d) Overall expansion of HPT and IPT.
 - (e) Absolute bearing vibration measurement of each bearing in both X & Y directions.
 - (f) Stator winding vibration measurement in radial and tangential directions.
 - (g) Axial shift of the rotor, (three sensors).
 - (h) Turbine speed, (3 sensors).
 - (i) Emergency stop and control valve position.
 - (j) Main steam and hot reheat steam inlet temperature and pressure.
 - (k) Bearing metal and drain oil temperature.
 - (l) Turbine metal temperature.
 - (m) In case of vibration, shaft mounted reference detectors and required supervisory instrument circuitry shall also be provided.
 - (n) Any other measurement recommended by the turbine manufacturer or required for the safe and reliable operation.
- iii) The system shall be provided with suitable hardware for necessary signal processing. The system should be capable of signal distribution and interfacing with other control systems. The system should suitably interface with MMIPIS system supplied by bidder.

For all vibration measurements indicated under (ii) above, a Microprocessor/computer based system shall also be provided to achieve the following functions

- a) On-line spectrum/harmonic analysis
- b) Identification of the exact nature of failure resulting in increase in bearing vibration and direct message on the TFT indicating the exact nature of fault e.g. misalignment, shaft crack, bearing looseness etc through use of intelligent software packages.
- c) Storage and comparative analysis of vibrations.
- d) Generation/ analysis of bode plot/ orbit plot and time waveform/ nyquist plot/ shaft centre line plot/ cascade and water fall plot.
- e) All the vibration parameters as well as turbine supervisory parameters shall also be fed to the turbine control system (TCS) through hardwiring or through suitable link so that all these parameters are suitably displayed on the TG



control TFTs. All required I/O cards and other processing modules etc. shall be provided for this purpose.

- f) Test calibration jigs for site calibration of all sensors of TSS shall be provided. Telephone jacks shall be incorporated in all the TSS cubicles for communication during site calibration etc.

6.3.10 BFP Turbine Supervisory Instruments

- i) In addition to the instruments specified previously, the following instruments shall be provided for supervisory purpose. The supervisory equipment shall include detection, indication and recording of the following as a minimum.
 - (a) Shaft eccentricity
 - (b) Axial shift, (with three pickups)
 - (c) Differential expansion.
 - (d) Overall expansion.
 - (e) Speed (triple pickups)
 - (f) Turbine casing and bearing metal temperature for all bearings.
 - (g) Stop valve metal temperature
 - (h) Bearing pedestal vibration (both in horizontal and vertical direction)
- ii) Duplex K-type thermocouples/duplex 100 ohm platinum RTD's shall be provided for the metal temperature and on the thrust bearing faces. All the elements of the thermocouples shall be terminated by appropriate extension cable to cold junction compensation boxes.
- iii) Separate and independent hardware/electronics shall be employed for each of the TDBFPs.

6.3.11 Plant Performance Analysis, Diagnosis & Optimization (PADO) Software

The contractor shall provide PC based on- line plant performance analysis, diagnosis & optimization (PADO) system for the station. The PADO system shall incorporate the complete thermal design model of each unit. The model of each unit shall work together from the same PC for the complete plant. The system shall use the measured data from the C&I system through appropriate interface to be provided by the bidder. Instruments, which are specifically required for implementation of PADO, shall also be in the scope of contractor.

The PADO system shall provide the following functions in a modular and seamlessly integrated environment, using a common plant model and a dynamically shared database:



- i) **Performance analysis and monitoring of systems and components**
- a) Calculate thermal performance status of the plant and efficiency of generation using measured data.
 - b) Calculate all the key system performance indicators at system level such as heat rate, plant and equipment efficiency, generator output and controllable losses.
 - c) Analyze the impact of individual component performance on overall losses or gains in total megawatt generation.
 - d) Perform detailed analysis of each component including calculation of key performance indicators such as efficiency, heat transfer coefficient, TTD, DCA, and fouling factor.
 - e) What if analysis at system and component level.
- ii) **Emission analysis and monitoring**
- a) Monitor, track and analyze plant emissions such as SO₂, NO_x, CO and CO₂ in real time.
 - b) Monitor and analyze ESP and stack conditions such as temperature, humidity, gas flow rate and opacity.
 - c) Facilitate obtaining lowest emission while maintaining combustion efficiency.
 - d) Facility to set alarms to highlight conditions that violate predefined limits.
- iii) **System and performance diagnosis**
- a) Evaluate system and component performance degradation to detect worn plant equipment
 - b) Expert system diagnostics using neural and Bayesian belief networks and historical data for quick identification of problem pinpointing down to the component.
 - c) Identify degradation of measuring instruments.
- iv) **System and performance optimization**
- a) Recommend to operator controllable parameter settings to optimize given process or activity at the measured operating condition, using state of the art optimization techniques.
 - b) Optimize control system design to determine the optimum values of parameters for individual control loops.
- v) **Other functions**
- In addition to the above functions, the PADO system shall possess the following analytical features:
- a) Verify the accuracy and provide the correct estimated value of the faulty or missing measurements.



- b) Data created by one function shall be used to perform analysis using another set of functions without any processing or conditioning of the data.
- c) Simultaneous use of functions by one user on a single workstation or multiple users across multiple workstations.
- d) Create alternative configuration of a unit, to study the impact of component replacements or changing the routing of fluid flows.
- e) The PADO system should be fully compatible with the functions of BPOS

vi) Boiler performance optimization system

The contractor shall provide a PC based on-line boiler performance optimization system (BPOS) for each steam generator. The BPOS shall incorporate the complete thermal design model of the boiler capable of both forward and backward calculation of complete boiler thermal performance. The model shall be calibrated and made "Site Specific" based on series of field trials of thermal performance of the boiler during startup and prior to trial operation. The input for the BPOS shall be based on accurate and continuous on line grid measurement of the following:

- a. Flue gas temperature at economizer outlet using acoustic pyrometer.
- b. Flue gas oxygen.
- c. Other fluid temperature(s) entering and exiting various heat transfer banks.
- d. Coal characteristics

The BPOS shall be capable for continuous on-line calculation of the thermal performance of the boiler for the operating conditions indicating performance prediction zonal absorption, metal temperature and shall have necessarily the following features:

- Fuel switching capability.
- "WHAT IF" capability.
- Selective soot blowing of furnace/super heater based on trends of zonal absorption.
- Expert system diagnostics for quick identification of the 'Root Cause' of deviations from the predicted parameters.

The computer modeling and arriving at factors to make it "Site Specific" shall be to the approval of the owner.



The BPOS shall be furnished complete with the appropriate computer hardware to the approval of the owner.

vii) Other requirements

The PADO System, as described above, shall also include the following:-

- a) Boiler performance optimization packages including the optimized operation of soot blowing System.
- b) Boiler stress condition analyzer.
- c) Interactive water and gas chemistry management system.
- d) Regenerative cycle performance optimization system.

viii) Hardware requirements

- a) The hardware shall include a computer server and at least 5 workstations along with the complete networking in a LAN network.
- b) The implementation of all the associated hardware, networking and related work shall be the responsibility of the bidder in order to successfully operate the software.
- c) Values calculated by PADO software shall be available as calculated data base points in unit MMI database of distributed control system (DCS) (In purchaser's Scope) through appropriate interface to be provided by the bidder for display and recording.
- d) The supplier free of cost shall support the tools under warranty for a period of 5 years from the date of trial operation.



6.4 MEASURING INSTRUMENTS (PRIMARY AND SECONDARY)

- i) Measuring instruments/equipment and subsystems offered by the bidder shall be from reputed experienced manufacturers of specified type and range of equipment, whose guaranteed and trouble free operation has been proven. Further, all instruments shall be of proven reliability, accuracy, repeatability requiring a minimum of maintenance. They shall comply with the acceptable international standards and shall be subject to purchaser's approval. All instrumentation equipment and accessories under this specification shall be furnished as per technical specifications, ranges, make/ numbers as approved by the purchaser during detailed engineering.
- ii) Every panel mounted instrument requiring power supply shall be provided with a pair of easily replaceable glass cartridge fuses of suitable rating. Every instrument shall be provided with a grounding terminal and shall be suitably connected to the panel grounding bus.
- iii) All local gauges as well as transmitters, sensors, and switches for parameters like pressure, temperature, level, flow etc. as required for the safe and efficient operation and maintenance as well as for operator and management information (including all computation) of equipment under the scope of specification shall be provided.
- iv) The necessary root valves, impulse piping, drain cocks, gauge-zeroing cocks, valve manifolds and all the other accessories required for mounting/erection of these local instruments shall be furnished, even if not specifically asked for, on as required basis. The contacts of equipment mounted instruments, sensors, switches etc. for external connection including spare contacts shall be wired out in flexible/rigid conduits, independently to suitably located common junction boxes. The proposal shall include the necessary cables, flexible conduits, junction boxes and accessories for the above purpose. Double root valves shall be provided for all pressure tapings where the pressure exceeds 40 kg/sq cm.
- v) For protection purposes, transmitters can be considered in place of switches.

6.4.1 Configuration, Maintenance, Diagnostics & Record-Keeping facility for Electronic Transmitters and Analysers.

- i) The bidder shall provide a dedicated and standalone PC based system with suitable interface to DDCMIS system for each of the generating units for centralised configuration, maintenance, diagnostics & record-keeping for all electronic transmitters.

The analog input modules in the Control System will use 4-20 mA analog signals and segregate the superimposed digital signal to be used in the PC based system referred above. The PC based system shall access these information either through the system bus or through any dedicated network as per Bidder's standard practice.



- ii) The bidder shall provide following facilities as a minimum through software:
- (a) Constant scanning to monitor faults of changes to instrument configuration.
 - (b) Purchaser-defined and standard calibration and configuration procedures for all transmitters.
 - (c) Constant signal data collection facilities to maintain continuously updated records.
 - (d) Automatic tracking of configuration changes made in the field, such as may be introduced by hand-held communicator. All configuration function associated with hand-held communicators shall be available in the system.
 - (e) Event and log reports on screen as well as on printer.
 - (f) Any addition/deletion of transmitter will be reported on printer and logged in hard disk.

6.4.2 Specification for Electronic Transmitter for Pressure, Differential Pressure (DP), Flow and Level

Sl. No.	Features	Essential/ minimum requirements for electronic transmitter
1.	Type of transmitter	Microprocessor based 2 wire type, HART protocol compatible.
2.	Sensor type	Capacitance/Piezo-electric
3.	Accuracy	$\pm 0.1\%$ of span
4.	Output signal range	4-20 mA DC (analog) along with superimposed digital signal (based on HART protocol)
5.	Turn down ratio	30:1
6.	Stability	$\pm 0.1\%$ of calibrated span for six months up to 70 Kg/cm ² and $\pm 0.25\%$ for range more than 70 Kg/cm ² (g).
7.	Zero and span drift	$\pm 0.015\%$ per deg. C at max span and 0.11% per deg. C at min. span.



Section 6 (Control and Instrumentation Works)

8.	Load impedance	500 ohm (min.)
9.	Housing	Weather proof as per IP- 67 with durable corrosion resistant coating
10.	Over Pressure	150% of max. operating pressure
11.	Connection (Electrical)	Plug and socket type
12.	Process connection	1/2 inch NPT (F)
13.	Span and Zero adjustability	Continuous, tamper proof, remote as well as manual from instrument with zero suppression and elevation facility.
14.	Accessories	(a) Diaphragm seal, pulsation dampeners, siphon etc. as required by service and operating condition (b) 2 valve manifold for absolute pressure transmitters, 3 valve manifold for gauge/ vacuum pressure transmitters and 5 valve manifold for DP/ level/ flow transmitters. (c) For hazardous area, explosion proof enclosure as described in NEC article 500.
15.	Diagnostics	Self indicating feature
16.	Power supply	24V DC \pm 10%
17.	Adjustment/ calibration/ maintenance	Centralised PC based system as per clause 6.4.1. In addition total five (5) no. of hand held calibrators per unit shall be provided.
18.	Response time	Suitable to meet closed loop control reaction time specified elsewhere



Notes

- (i) In case it becomes necessary to use a DP transmitter for pressure measurement (furnace pressure & condenser vacuum etc.) then a 3 valve manifold should be used in place of 2 valve manifold (furnace pressure, condenser vacuum etc.).
- (ii) Type of transmitter i.e. gauge pressure or absolute pressure, shall be as per specific requirement and as approved by purchaser.
- (iii) For heavy fuel oil (HFO), light fuel oil (LFO) applications, stainless steel(SS) capillary with wafer element with ANSI RF flanged ends are to be provided.
- (iv) For heater level applications ultrasonic/radar type can be considered.

6.4.3 Temperature Sensing Elements and Cold Junction Compensation Boxes

i) Temperature Elements

Sl. No.	Features	Essential/minimum requirements
1.	(a) Type of thermocouple	16 AWG wire of chromel-Alumel (Type K) or 24 AWG wire Pt-Rhodium Pt (Type R); ungrounded type depending on operating temperature range.
	(b) Type of RTD	3 wire/4 wire - Pt RTD 100 ohm (as per DIN-43760) class-A
2.	No. of elements	Duplex
3.	Housing/Head	IP-55/die-cast aluminium
4.	(a) Sheathing of thermocouple	Swaged type magnesium oxide insulation
	(b) Sheathing of RTD	Metal sheathed, ceramic packed
5.	Calibration and accuracy	As per IEC-751/ANSI-C-96.1 0.5% of range for RTD.
6.	Characteristic	Linear with respect to temp, within $\pm 1/2$ percent of top range value
7.	Accessories	- Thermowell (as specified below) and shall be spring loaded for positive contacts with the well.



- Compensating cable up to CJC box.
- Plug in connectors.

8. Standard ANSI C 96.1 for thermocouple and ASME PTC-19.3 for thermowell

For turbo generator set, following are also applicable-

- a) Thermocouples for stator core shall be of copper compensation, grounded type of size 0.5mm². Thermocouple for bearing babbit temperatures shall be type K, Ni-Cr-Ni of size 6x0.5mm².
- b) Sheathing is not applicable for generator stator core thermocouples in case the same is as per contractor's schedule.

ii) For detection of leakage of various drain valves, drain pipe metal temperature thermocouples shall be provided (approx 60 nos. minimum) as per the following specification. Also for Drum, SH, RH metal temperature thermocouples shall be provided with following specification.

- a) Measuring medium : Metal temperature
- b) Metal of thermocouple element : Chromel- Alumel Type K
- c) Type of thermocouple : Duplex with separate hot junctions, ungrounded type.
- d) Insulation : Mineral insulation
Magnesium Oxide
- e) Thermocouple wire gauge : 16 AWG
- f) Protective sheath : SS 321
- g) Protective sheath dia : 8 mm O.D
- h) Characteristics of thermocouple : Special limits of error as in ANSI MC 96.01.1975
- i) Mounting accessories : 1/2" BSP SS sliding end connector, weld pad, weld on clamps of heat resistant steel SS310.
- j) Cold end sealing : SS pot seal with colour coded PTFE headed sleeve insulated flexible tails. Sealing compound - Epoxy resin.



- k) Minimum bending radius : 30 mm
- l) Length of T/C : 30 mtr. (minimum)

iii) **Thermowell (for process temp. elements)**

- (a) Shall be one piece solid bored type of 316 SS of stepless tapered design. (As per ASME PTC 19.3 1974)
- (b) For mill classifier outlet long life solid sintered tungsten carbide material of high abrasion resistance.
- (c) For air & flue gas 316 SS protecting tube with welded cap.
- (d) For furnace zone, impervious ceramic protecting tube alongwith Incoloy supporting tubes and adjustable flanges.

iv) **C J C Boxes**

- a) Ref. temp. $60^{\circ}\text{C} \pm 1.3^{\circ}\text{C}$ for type K thermocouple
 $60^{\circ}\text{C} \pm 2^{\circ}\text{C}$ for type R thermocouple
- b) Effect of ambient temp. variation $\pm 0.1\%$ per 10°C
- c) Material 4 mm thick fibreglass reinforced polyster
- d) Protection class of CJC boxes IP 55
- e) Cable entry Bottom with gland plates suitable for cables used along with blanking facility
- f) Temp. control Automatic with remote temperature monitoring
- g) Power supply 240 V AC, 50 Hz

v) **Temperature Transmitter**

The temperature transmitter of following types (2-wire temperature transmitter directly powered from 4-20mA input cards of DDCMIS) fully compatible with



thermocouples and RTDs shall be provided. Temperature compensation of the thermocouples shall be performed in the temperature transmitter itself.

a. Single Input Head mounted Temperature Transmitter

These shall be suitable for mounting in the head of temperature element itself. The protection class of head of thermo well along with its plug-in connector shall be min. IP65.

b. Single Input DIN-rail mounted Temperature Transmitter

These shall be suitable for mounting on DIN-rails in JB's. Protection class of JB's shall be IP 65 minimum. This temperature transmitter shall be the ones which are especially designed for DIN-rail mounting with IP 20 protection class. These shall have terminals for input/output provided on front side when mounted on DIN-rail. Head mounted temperature transmitter with clamps to make it suitable for DIN-rail mounting shall not be acceptable under this category.

c. Dual-input Temperature Transmitter With Indicator:

These shall be suitable for mounting on pipes/ supports. Indicator shall be provided with these transmitters. These transmitters shall have bump-less change over facility to second sensor in case first sensor fails. This change-over is to be alarmed. Protection class shall be IP65 minimum.

The exact applications for which this type of transmitter is to be provided shall be finalized during detailed engineering.

d. Common requirements for each of the above type of temperature transmitters

Output	2-wire (power supply from input card of Control System) with 4-20mA output with superimposed HART protocol signal.
Input	Same transmitter shall be capable to handle Pt-100 RTD , Thermocouples – K&R types (input type to be selectable at site through HART terminal)
Isolation	min. 500 V AC
EMC compatibility	as per EN 61326
Operating ambient temperature	0 to 85 deg C (without indicator) 0 to 70 deg C (with indicator)
Power supply	compatible with input module of Control System



Accessories	Mounting arrangements including clamps etc.
Composite Accuracy (Refer note 2)	(a) For head mounted and DIN-rail mounted types: RTD= $<0.4\%$ of 0-250 deg C span T/C-K type= $<0.4\%$ of 0-600 deg C span T/C-R type= $<0.4\%$ of 0-1000 deg C span CJC accuracy (for thermocouples) shall be $=< 1$ deg C (b) For dual-input type: RTD $=<0.25\%$ of 0-250 deg C span T/C-K type= $<0.2\%$ of 0-600 deg C span CJC accuracy (for thermocouples) shall be $=< 1$ deg C

Notes:-

1. In case of failure (open or burn-out) of RTD/thermocouple, temp. Transmitter shall provide low temperature output.
2. Composite Accuracy is to be calculated as summation of all applicable accuracies of temp transmitter, for converting sensor input to output in 4-20 mA (e.g., basic accuracy, digital accuracy, D/A accuracy, etc.) and temperature effect on these accuracies at ambient temperature of 50 deg C, based on the figure/ formula given in the standard product catalogue for span as specified above for various types of Temperature Elements specified. All such accuracy/ temp effect figures in catalogue shall be first converted to deg C, and then percentage of this converted accuracy in specified span shall be calculated to compare with the specified composite accuracy figures.

6.4.4 Flue Gas Analyser Instruments:

i) Common to all analysers

- | | | | | |
|----|------------------------|--------|---|----------------------------|
| a. | Output signals: | Analog | : | 4-20 mA DC |
| | | Binary | : | 2 NO + 2 NC for high alarm |
| b. | Zero & span adjustment | : | | Available |
| c. | Ambient temp. | : | | 60°C |
| d. | Indication | : | | Digital |



e.	Enclosure type/material	:	Weather & dust proof (IP 55) die- cast aluminium/ SS
f.	Type of electronics	:	Microprocessor based with self diagnostic facility
g.	Digital signal transmission	:	RS 232 link and to suit connections protocol to DDCMIS
h.	Calibration	:	Auto & Manual (from Remote)
i.	Error diagnostic	:	To be provided
j.	Others :		If analyser provides superimposed HART signal on 4-20 mA DC output, it shall also be connected to PC based station specified under clause 6.4.1.

ii) Specific requirements of flue gas analysers

Specification requirements	SO2 analyser and NOx analyser cum monitor (combined)	Oxygen analyser cum monitor	CO analyser cum monitor	Dust density stack opacity monitoring
a) Type of instrument	Sampling type	Heated type in-situ	In-situ type	In-situ dry type visible light (through LED) stack
b) Principle of measurement	Radiation absorption	Partial-pressure using Zirconium Oxide Cell	IR double beam absorption	Transmission and absorption
c) Measurement range	0-200/0-1000-0-2000 selectable in mg/m ³	0-25% oxygen programmable up to min.0.5% of O ₂	0-999 selectable in 0-100, 0-200, 0-500, 0-999ppm	0 to 999mg/ m ³
d)Accuracy	± 1% of F.S.	± 1% of F.S.	± 5% of F.S.	± 0.2% of F.S.



Section 6 (Control and Instrumentation Works)

e)Linearity	$\pm 1\%$ of F.S.	$\pm 1\%$ of F.S.	$\pm 2\%$ of F.S.	$\pm 1\%$ of F.S.
f) Repeatability	$\leq 0.5\%$ of Span	$\leq 0.5\%$ of Span	$\leq 0.5\%$ of Span	$\leq 0.5\%$ of Span
g)Response time (upto 90% of full scale)	5 sec. or less	5 sec. or less	5 sec.	5 sec.
o Temperature drift	$\pm 1\%$ / 10 deg. C	$\pm 0.005\%$ 2 deg. C	Automatic temp compensation	1% in 24 hrs.
o Zero drift	< 1% span/ week		<1% span/ week	
o Span drift	< 1% measured value/week		<1% measured value/ week	
h)Sensor type	Luminiscence/ /IR	. zirconium oxide cell	IR	Luminiscence
i)Operating temperature range	0-300 deg.C	0-450 deg.C	0-300 deg.C	0-300 deg.C
j)Filter	Ceramic 3.5 micron	Ceramic 3.5 micron	Ceramic 3.5 micron	Ceramic 3.5 micron
k)Sampling system	With dual sampling through heavy duty pumps (with bypass pump), solenoids filters etc. alongwith coolers and flow meter and level switch in gas coolers for auto draining purpose, moisture detection/ alarm unit.	Not applicable	Not applicable	Not applicable



l)Accessories purging system	Yes (auto scavenging facility)	Purging system	Yes	Yes
m)Compensation for temp., Pr., moisture, for O2 including cables upto JB	Yes to be provided and shutter solenoid for isolating lens during unit trip and purge air failure automatically	Automatic temperature control of heating circuit through thermostat..	Yes to be provided and shutter solenoid for isolating lens during unit trip and purge air failure automatically	Yes to be provided and shutter solenoid for isolating lens during unit trip and purge air failure automatically
n)Location	Chimney	Airheater inlet	Airheater inlet and on chimney	Chimney

6.4.5 Vibration Monitoring System

- i) Microprocessor based vibration monitoring system shall be provided for ID fans, FD fans, PA fans, CEPs , BFPs ,and all other pumps/ fans operating on 3.3kv/11kV.The number of bearing locations to be monitored on each fan/ pump shall be as per requirements finalized during detailed engineering but not less than 2 bearing locations for each fan/pump (except for vertical pumps for which one bearing location may be sufficient).
- ii) The vibration monitoring system shall be furnished on a system basis including vibration transducers with low noise flexible cables in flexible conduit, terminated in local terminal boxes, necessary pre-amplifier/electronics mounted in local weather proof boxes, vibration monitors, mounting racks and cabinets. The vibration monitoring system shall include all power supplies, interconnecting cabling, calibration equipment, indicators, integrating units, signal conditioning devices and all other accessories required for monitoring of vibration at each point.
- iii) Bidder shall offer 2 channel vibration monitors for each measurement location catering for horizontal and vertical measurements. Offered vibration monitors shall be modular in construction, plug in type and suitable for 19" rack mounting.
- iv) Eddy current type proximity transducers shall be used. However, the finally selected sensor type shall also depend on recommendation of the equipment manufacturer & suitable for application requirement. Transducers shall be furnished in weatherproof housing suitable for field conditions.



- v) Vibration monitoring system shall give buffered output of 4-20 mA DC for each point monitored. The signal shall be suitable for use as an input to DDCMIS as well as for analog recording & analysis, linear in proportion to vibration velocity as well as displacement. Monitor shall provide vibration indication calibrated in velocity units along with provisions of changing to displacement unit (field-programmable) for each measurement point in both horizontal & vertical planes. For each vibration monitor, two independent potential free contacts shall be made available for alarm & trip purposes.
- vi) The vibration monitor racks with power supplies shall be mounted in a separate self standing cabinet to be located in CER. The number of racks and power supplies shall be such that on failure of a single power supply/module, not more than four monitors shall be affected. The vibration monitoring cabinet shall be fed from redundant UPS feeders with auto changeover scheme.
- vii) The functional requirement for vibration monitoring system shall include but not be limited to the following:
- a) Vibration monitor front face status indications shall be available for indications of healthy conditions of pick up circuit, monitor circuit and power supply. Also set point indication with set point adjustment facility for setting alarm & trip levels shall be provided.
 - b) The facility shall be available from front of mounting rack for functional checking of monitors with inhibition of alarm and trip contact outputs during test. Alarm inhibition shall also be provided during start-up.
- viii) All vibration monitoring equipment shall be functionally tested for circuit continuity and output response. All the components & interconnection cables shall be tested to ensure compliance with the specification requirements and all other applicable codes & standards.

In case it is the proven standard practice of a Bidder to provide vibration monitoring TFTs instead of dedicated monitors with the signal conditioning equipment in control equipment room, the same shall also be acceptable. However, all relevant functional requirements detailed above shall be met and the system shall be subject to purchaser's approval.

6.4.6 Specification for Flow Elements

i) Orifice Plate

Features	Essential/minimum requirements
a) Type	Concentric as per ASME PTC-19.5 (Part-II), ISA RP-3.2, 1960 or BS-1042



b) Material	316 SS
c) Thickness	3 mm for main pipe diameter up to 300 mm and 6 mm for main pipe dia above 300 mm.
d) Material of branch pipe	Same as main pipe
e) Root valve type	Globe
f) Root valve material	316 SS
g) Root valve size	1 inch
h) Tappings	Flanged weld neck. 3 pairs. of tapping.
i) Beta Ratio	0.34 to 0.7
j) Beta Ratio calculation to be submitted	Yes
k) Assembly drg. and flow Vs DP curves	Yes
l) Accessories	Root valves, flanges, vent/drain hole(as required)

Contractor shall submit certified flow calculation and differential pressure versus flow curves for each element for purchaser's approval. Sizing calculation, precise flow calculation for all the flow elements, fabrication and assembly drawings and installation drawings shall be submitted for purchaser's approval. One flow element of each type shall be calibrated in the test laboratory for validation of computed flow calculations.

ii) Flow Nozzle

Features	Essential/minimum requirements
a) Type	Long radius, welded type as per ASME PTC-19.5 (Part-III) or BS-1042
b) Material	316 SS 321 SS for high temperature and corrosive atmosphere
c) Thickness	Suitable for intended application.



d) Material of branch pipe	Same as main pipe
e) Root valve type	Globe
f) Root valve material	316 SS
g) Root valve size	1 inch
h) Tapping	D and D/2 (3 Nos. of tappings)
i) Beta ratio	Around 0.7
j) Beta ratio calculation to be submitted	Yes
k) Assembly drg. and flow Vs DP curves	Yes
l) Accessories	Root valves, vent and drain hole.

Contractor shall submit certified flow calculation and differential pressure versus flow curves for each element for Purchaser's approval. Sizing calculation, precise flow calculation for all the flow elements, fabrication and assembly drawings and installation drawings shall be submitted for purchaser's approval. One flow element of each type shall be calibrated in the test laboratory for validation of computed flow calculations.

6.4.7 Specification For Local Gauges & Rotameter

i) Local Gauges

Sl. No	<u>Features</u>	<u>Essential/ minimum Requirements</u>		
		Pr. gauge/ DP gauge/ Draft gauges	Temperature gauge	Level gauge
a)	Sensing Element and material	Bourdon for high pressure, diaphragm/ bellow for low pr. of 316 Stainless steel	Mercury in steel for below 450°C and inert gas actuated for above 450°C of SS bulb and capillary.	Tempered * toughened borosilicate gauge glass steel armoured reflex or transparent type.
b)	Body material	Die-cast aluminium	Die-cast aluminium	Forged carbon steel/ 304 SS
c)	Dial size	150mm	150 mm	Tubular covering entire range



d)	End connection	1/2 inch NPT (F)	3/4inch NPT (F)	Process connection as per ASME PTC and drain/vent 15 NB
e)	Accuracy	±1% of span	± 1% of span	± 2% of span
f)	Scale	Linear, 270° arc graduated in metric units	Linear, 270° arc graduated in °C	Linear vertical
g)	Range selection	Cover 125% of max. of scale	Cover 125% of max. of scale	Cover 125% of max. of scale
h)	Over range test	Test pr. for the assembly shall be 1.5 to the max. design pr. at 38°C.		
i)	Housing	Weather and dust proof as per IP-55	Weather and dust proof as per IP-55	CS/ 304 SS leakproof
j)	Zero/span adjustment	Provided	Provided	--
k)	Identification	Engraved with service legend or laminated phenolic name plate		
l)	Accessories	Blow out disc, siphon, snubber, pulsation dampener, chemical seal (if required by process) gauge isolation valve	SS Thermowell	Gasket for all KEL-F shield for transparent type Vent and drain valves of Steel/SS/ CS/Alloy as per process requirement
m)	Material of Bourdon/ movement	316 SS / 304 SS	316 SS / 304 SS	

Notes:-

*Bicolour type level gauges will be provided for applications involving steam and water except for condensate and feed water services.

Length of gauge glass shall not be more than 1400 mm. If the vessel is higher, multiple gauge glasses with 50 mm overlapping shall be provided.



Where the process fluids are corrosive, viscous, solid bearing or slurry type, diaphragm seals shall be provided. Parts below the diaphragm shall be removable for cleaning. The entire volume above the diaphragm shall be completely filled with an inert liquid suitable for the application.

For HFO, LFO applications, SS capillary with thin wafer element with ANSI RF flanged ends are to be provided.

ii) Specification for Rotameters

Sr. No.	Features	Essential / minimum requirements
a)	Type scale	Variable linear type
b)	Fluid media	Water/oil
c)	Material body	Transparent toughened glass
d)	Material of float	316 SS
e)	Indicator	Magnetic float
f)	Accessories	Flange, orifice in case of bypass rotameter (for line size above 50 mm)
g)	Housing protection class	IP-55
h)	Accuracy	$\pm 2\%$

6.4.8 Specification for Process Actuated Switches

Features	Essential / minimum requirements		
	Pressure/draft switches/ DP switches	Temperature switches	Level switches
a) Sensing element	Piston actuated for high pressure and diaphragm or bellows for low pressure/vacuum	Vapor pressure sensing, liquid filled bellow type with SS bulb and capillary (10 m minimum)	Capacitance types for oil and dirty medium, water, condensate application. Float type switches for applications as decided by Purchaser during detailed engineering.



			Capacitance/ Conductivity/ Ultrasonic type for acid and alkali application.
			Radio-frequency/ ultrasonic type for ash hopper, ash slurry application.
b) Material	316 SS	Bulb 316 SS/ capillary 304 SS	316 SS
c) End connection	½ inch NPT (F)	½ inch NPT (F)	Manufacturer standard
d) Over range proof pressure	150% of max. design pressure	-	150% of max. design pressure
e) Repeatability		± 0.5% of full range	
f) No. of contacts	2 NO +2NC SPDT snap action dry contacts		
g) Rating of contacts	60 V DC, 6 VA (or more if required by DDCMIS or PLC)*		
h) Elect. connection	Plug in socket		
i) Set point/ dead band adjustment	Provided over full range		
j) Enclosure	Weather and dust proof as per IP-55		
k) Accessories	Syphon, snubber, chemical seal, pulsation dampeners as required by process	Thermo well of 316 SS and packing glands	All mounting accessories
l) Mounting	Suitable for enclosure/ rack mounting or direct mounting	Suitable for rack mounting or direct mounting	-



Note: Where the process fluids are corrosive, viscous, solid bearing or slurry type, diaphragm seals shall be provided. Parts below the diaphragm shall be removable for cleaning. The entire volume above the diaphragm shall be completely filled with an inert liquid suitable for the application.

6.4.9 Specification for Indicators, Recorders, Integrators

i) Indicators, Recorders

Sl. No	Features	.Essential/minimum requirements		
		Digital indicator	Vertical indicator	Recorder
a)	Type	4½ digit LED seven segment display.	Permanent magnet moving, coil, (PMMC) single element with strip scale	1 24 point strip chart, micro-processor based programmable 2 3-Pen continuous
b)	Input signal	4-20 mA DC	4-20 mA DC	4-20 mA DC, thermo couple and RTD input
c)	Display character	14 mm size decimal continuous reading	Analog linear with pointer	Linear on chart paper
d)	Accuracy	± 0.1% of full scale(at 20 °C -30 °C) ± 2 LSD	± 1% of full scale	± 0.3% of span
e)	Response time	250 m sec.	2 sec. (full span)	2 sec. (full span)
f)	Signal Connection	Screwed	Screwed	Screwed
g)	Power Connection	Screwed	N/A	Screwed
h)	Zero/span adjustment.	Shall be possible from the front of instruments.		



i)	Chart speed			Adjustable continuously from 1-1200 mm/hr. (step of 1mm/hr.)
j)	Power supply	240V AC	N/A	240V AC
k)	Power supply fuse connection	Yes	N/A	Yes
l)	Mounting	Fully compatible to the mosaic grid	Fully compatible to the mosaic grid	Fully compatible to the mosaic grid
m)	Protection class	IP-20	IP-20	IP-20
n)	Chart speed			Adjustable continuously from 10-600 mm/Hr
o)	Identification	-----Engraved Phenolic tag -----		
p)	Dimension	96 mm (W) x 48 mm (H)	36 mm (W) x 144 mm (H)	144 mm (W) x 144 mm (H)
ii)	Integrator shall have total display 6 digit, 4mm high. Totaliser mechanism shall be as per manufacturer's standard. It shall have an accuracy of + 0.3% a span. Input shall be 4-20mA DC.			

6.4.10 Electric to Pneumatic (E/P) Converters

E/P converters and associated accessories shall be furnished in accordance with the specifications given below :

Air supply :	1.5 kg/cm sq.,
Input signal :	4-20m A DC(as required by the design of control system),
Output signal :	0.2 to 1.0 kg/cm sq.,
Linearity :	0.5% of span or better,
Hysteresis :	0.1% of span or better,
Ambient temp effect :	less than 0.02% of span per deg C between -20 deg. To +60 deg C.
Mounting :	close to actuator (but not on the actuator),
Output capacity:	to suit the actuator,
Protection class:	IP 55.
Allowable drift rate	±2% of set point/ hour maximum.



On loss of control signal, the last set point pressure shall be maintained so that the associated control valve remains in stay put condition.

6.4.11 Displacer Type Level Transmitters

- i) Displacer type level transmitters shall be provided for level measurements of the vessel under vacuum or low pressure applications (viz. condenser hotwell, LPH-1, 2, 3 level measurements).
- ii) The displacer spring and tube material shall be K-monel. The float movement shall be transmitted to the pivot mechanism by a torque device incorporating a positive seal between float cage interior and the transmitting mechanism without the use of stuffing boxes. Level transmitters, not incorporating torque tube mechanism, shall not be acceptable.
- iii) Level transmitters shall be complete with external float chambers of cast or fabricated steel construction with 2 inch upper side and lower bottom socket weld connections unless otherwise required as per main vessel connections. Displacement float chambers shall be designed for internal access without breaking the level connection primary piping. Matching weld neck counter flanges shall be supplied alongwith the instrument.
- iv) Accuracy (including combined effect of linearity, hysteresis and repeatability) shall be $\pm 0.75\%$ of span or better.
- v) Connection details, other technical features and materials of construction shall be suitable for the intended applications and shall be subject to purchaser's approval.
- vi) The transmitters shall be provided with IP-55 protection class with durable corrosion resistant coating.
- vii) The transmitters shall be able to provide digital signals superimposed on 4-20 mA signal as per HART protocol.

6.4.12 Positive Displacement Type Flow Transmitters

- i) The bidder shall provide positive displacement type flow transmitters for fuel oil flow measurement, suitable for the fuel oil being used for the project, i.e., keeping in view the pressure, temperature and viscosity of the fuel oil.
- ii) The meter shall be a volumetric meter type consisting of two meshing oval wheels driven by the fluid. Each revolution of the oval wheels shall displace a precisely known volume of the fluid from inlet to outlet. The housing/measuring chamber and oval wheels shall be of 316 SS.
- iii) The measurement accuracy of the transmitter shall be better than $\pm 0.2\%$.



- iv) The transmitter shall provide suitable 4-20mA DC output signal for control and indication/recording. Converters if necessary shall be provided to generate the 4-20mA signal.
- v) A local indicator of fuel oil flow shall also be provided. The instrument shall be calibrated in tons/hr.
- vi) Suitable strainer shall be provided before the transmitter for the protection of oval wheel meters against foreign matter contained in the fuel oil.
- vii) The exact model no. and type of material being used, etc., shall be subject to Purchaser's approval during detailed engineering without any price repercussion to Purchaser.

6.4.13 Impact Head Type or Ultra sonic type Flow Element

Impact head type or ultra sonic type flow elements shall be provided for measurement of CW flow.

a) Impact Head Type:

- i) The impact head type element shall be tubular insert type with four impact ports facing upstream direction, located precisely for determination of average flow velocity and shall be of 316 SS.
- ii) Accuracy shall be $\pm 1.0\%$ of actual value or better. Repeatability shall be $\pm 0.01\%$ of actual value or better.
- iii) The elements shall be supplied complete with mounting hardware, end support plugs and CS valve manifold (1/2" NPT connection) for instrument connections. All pertinent data including Purchaser's instrument tag no. for the flow element shall be punched on a stainless steel plate and affixed to the element.
- iv) On line retracting facility and flushing arrangement shall be provided.

b) Ultra sonic type Flow Meter

- i) Ultrasonic Flow meter shall be dual path transit time clamp-on type.
- ii) The flow meters shall be of proven reliability, accuracy and repeatability requiring a minimum of maintenance. They shall comply with relevant international standards and shall be subject to approval.
- iii) All accessories required for mounting/erection of these instruments shall be furnished, erected and installed as necessary for completeness of the system though not specifically asked for. Also



the equipment shall include necessary cables, flexible conduits, junction boxes required for the purpose.

iv) Flow meters shall be provided with suitable environment protection devices/structures such that they shall be suitable for continuous operation in the operating environment of a coal fired utility station without any loss of function or departure from the specification requirements.

v) Technical Requirements

Type	Transit time Clamp On Ultrasonic meter
Mounting Style	Dual path with two sets of transducers on the same pipe
Flow measurement	Instantaneous Flow rate as well as totalized flow
Power supply	230 V AC
Outputs :	
Analog Current	Isolated 4-20mA linear outputs for each path
Binary	Contact relay outputs, 2 NO + 2 NC for alarm
Communication ports	RS 232 C digital Hand held terminal port
Display/Indication	Flow meter with LCD screen backlight based local display and keypad. If required, transmitter shall be suitably located away from the sensor for better access and visibility.
Recording / Totalizing/Logging Facilities	Yes. Should be able to compute cumulative flow over intervals selectable by owner i.e., daily, weekly, monthly etc. The data shall be stored in the memory of flow computer for access in future.



Software features	Compensation for any cross path errors Programming, configuration, shall be possible from front panel.
Diagnostics	False signal tolerance , power supply failure etc.
Protection class	IP-65 or better, Weather protection against direct sunlight, rain etc for Flow meter and suitable for Cooling water for Transducer.
Accuracy	+/- 1%
Electrical connection	Plug and socket
Pipe location	Underground
Accessories	All mounting hardware required like clamping fixtures, mechanism to remove the transducers online, interconnecting cables etc All weather canopy for protection from direct sunlight and direct rain. Material of all fittings shall be SS 316.

- vi) The Bidder shall submit certified flow calculation and differential pressure Vs. flow curves for each element for Purchaser's approval. Sizing calculation, precise flow calculation for all the flow elements, fabrication and assembly drawings and installation drawings shall be submitted for Purchaser's approval.



6.5 STEAM AND WATER ANALYSIS SYSTEM (SWAS)

- i) The purity of the condensate, feedwater, steam etc. shall be continuously monitored through on-line analysis system. The on-line chemical analysis for pH, conductivity, hydrazine, sodium ion, silica, dissolved oxygen, etc. shall be carried out in the plant cycle at strategic points. The exact sample points, their location, type of chemical analysis to be carried out for each sample, measurement ranges etc., shall be subject to the approval of the Purchaser. The system shall be generally designed in accordance to the recommendation of ASME PTC 19.11 Part-II, water & steam in power cycle.
- ii) The bidder shall provide the chemical analysis system as a composite system including sample piping, valves, grab sample collection facility, gauges/indicators, coolers, on- line analyzers etc.

6.5.1 SWAS Panels

- i) Sample conditioning panel (wet section) shall house bulk head type fittings, removable cartridge type filters, pressure reducing elements, flow rate control, secondary coolers, grab sample valve and other sample conditioning equipments. For each sample, pressure gauge, temperature gauge, flow indicator, back pressure regulating valve, grab sample valve shall be provided on front of panel. The grab sampling facility and quick disconnect patch board facilities shall be provided on this panel.

Analyzer panel (dry section) shall house cells, analyzers, monitors etc.

- ii) The above panels shall be physically separate from each other and shall be mounted in the air-conditioned SWAS room (common for 2 units). Sample conditioning panel shall be corridor type with walkway. The analyzer panel shall be free standing and of totally enclosed construction. The panel sheet thickness shall be 2.5mm except for doors which shall be of 2.0 mm thickness. All SWAS panels shall be designed for ready access of components for easy maintenance. The layout and general arrangement of these panels shall be subject to Purchaser's approval.
- iii) Primary cooling of all samples having temperature in excess of 45 deg C shall be provided through an individual sample cooler (primary cooler) of submerged helical coil type of shell and tube design with removable shell, meeting the intent of ASTM D 1192-1977, to bring down the temperature to around 45°C. These coolers shall be rack – mounted and located at the field. The primary coolers shall use water from equipment cooling water system. The design, construction materials and technical features of the coolers shall be subject to Purchaser's approval. However, the sizing of the coolers should consider total sample flow plus 500 ml / min grab sample and a fouling factor of 0.2. All fittings, tubes & other wetted parts shall be 316 SS. All high pressure samples shall be provided with pressure reducing valves after primary cooler in the field.

Each sample stream with the required flow rate shall be finally cooled from



approximately 45°C to 25°C \pm 1°C or to a preset temperature required by the analyzer through an individual secondary cooler before passing the sample to the respective measuring cells and analyzer even in case, the corresponding analyzer is rated for higher sample temperature. The pressure of the samples shall be about 2 kg/cm² and flow rates shall be as required by the individual analysers. The secondary cooler shall use condensate quality chilled water at 20°C. All samples will be passed through cartridge type filters before being cooled in respective secondary coolers. The secondary coolers will also be of submerged helical coil type of shell and tube design meeting the intent of ASTM D 1192-1977. All tubes, fittings & wetted parts shall be 316 SS.

The chilled water for SWAS should be drawn from chiller plant of the plant A/C system, if required. The bidder shall provide two identical 100% capacity chilled water circulation pumps for the secondary cooling as detailed above. Loss in chilled water pressure, flows and rise in temperature shall be alarmed.

6.5.2 Specification of Analysers

6.5.2.1 Conductivity Analyser

- | | | |
|------|--|---|
| i) | Type: | |
| | a) Cell | Flow through type / removable type (withdrawable with sealing valve) |
| | b) Monitors | Electronic (microprocessor based) indicating type with multi range facility |
| ii) | Material: | |
| | a) Cell | Epoxy resin |
| | b) Electrode | Platinised |
| | c) Monitor body | Carbon steel |
| iii) | Monitor output: | |
| | a) 4 to 20mA DC for recorder | |
| | b) 4 to 20mA DC isolated output for DDCMIS | |
| iv) | Power supply | 240V, AC, 50Hz |
| v) | Accuracy | \pm 1 % of full scale span |
| vi) | Stability | \pm 1% of full scale per month
no cumulative |



- vii) Repeatability ± 0.3 of span
- viii) Annunciation contacts for monitors
 - a) Number 2 SPDT
 - b) Type Snap action micro switch
 - c) Rating 5 Amp, 240V; 0.2Amp, 220V DC
- ix) Mounting
 - a) Cell On line/ pipe mounted (on line in sample table)
 - b) Monitors Flash panel mounting
- x) Connection:
 - a) Process $\frac{1}{4}$ inch NPT(F) screwed for on line type.
 $\frac{3}{4}$ inch NPT (M) screwed for pipe mounted
 - b) Electrical $\frac{1}{2}$ inch NPT (F) screwed
- xi) Accessories
 - a) Automatic temperature compensation in the range 0-100⁰ C.
 - b) Ammonia (NH₃) removal equipment.
 - c) Sample coolers.
 - d) Flow and pressure regulators.
 - e) SS impulse tubing and fittings
 - f) Isolation & drain valves as required.
 - g) Other accessories as required.
 - h) Adequate length of cables for connecting coils to monitors.
 - i) Sample rate set valves.
 - j) Alarm settings and Alarm indications on monitor.
- xii) Range As per sample stream .



- xiii) Other particulars Cell shall be suitable for maximum pressure of 7 kg/cm² and maximum temp. of 100^oC

6.5.2.2 pH Analyser

- i) Type
- a) Cell Measuring and reference electrode combination with flow through type (polypropylene flow chambers).
- b) Monitors Electronic (microprocessor based) indicating type with adjustable range facility.
- ii) Material
- a) Measuring & reference Toughened sensitive.
- b) Electrode pH glass
- c) Monitor body Die-cast aluminum.
- iii) Monitor output
- a) 4-20m A DC for recorder
- b) 4-20 m A DC isolated output for DDCMIS
- iv) Power Supply 240V AC, 50 Hz
- v) Accuracy/repeatability. ± 0.03 pH/ + 0.02pH
- vi) Resolution ± 0.01 pH
- vii) Stability 0.02 pH per week.
- viii) Annunciation contacts for monitors.
- a) Number 2 SPDT high and low
- b) Type Snap action micro switch.
- c) Rating 5 A 240V AC, 0.2 A 220VDC.
- ix) Connection.
- a) Process 1/4 inch NPT(F) screwed
- b) Electrical 1/2 inch NPT(F) screwed



- x) Mounting
 - a) Cell Pipe Mounted.
 - b) Monitors Flush panel mounting.
- xi) Accessories
 - a) Automatic temperature compensation with fast response integral temperature sensors in the range 0-100 deg C
 - b) Co-axial cable as required
 - c) Sample coolers.
 - d) Flow and pressure regulators.
 - e) Standard pH solutions.
 - f) SS impulse tubing and fittings.
 - g) Isolation & drain valves as required.
 - h) Electrode holders.
 - i) Other accessories as required
 - j) Sample rate set valves.
 - k) Alarm settings and indications on monitor.
 - l) RF/EMI shielded, weather and corrosion proof casing.
- xii) Ranges As per sample stream .

6.5.2.3 Dissolved Oxygen Analyser.

- i) Type Electro-chemical
- ii) Material Die-cast aluminium
- iii) Output
 - a) 4-20m A DC for recorder
 - b) 4-20 m A DC isolated output for DCS.
- iv) Supply 240V AC, 50 Hz.
- v) Accuracy \pm 4% of full scale value.



- vi) Response:
 - a) Sensitivity \pm two (2) per cent overall.
 - b) Time (sensor) Less than 30 seconds for 90% step change.
- vii) Connection:
 - a) Process 1/4 inch NPT (F) SCRD.
 - b) Electrical 1/2inch NPT(F) SCRD.
- viii) Accessories
 - a) Sample cooler assembly with shut off valve at cooling water inlet, with thermometer and reducing valve at sample outlet.
 - b) Flow stabilizer.
 - c) Automatic temperature compensation.
 - d) Other accessories as required including chiller.
 - e) Calibration device.
- ix) Ranges As per sample stream
- x) Mounting Flush
- xi) Annunciation contacts
 - a) Number 2 SPDT.
 - b) Type Snap action micro switch.
 - c) Rating 5 Amp 240V AC, 0.2 amp 220V DC.

6.5.2.4 Silica Analyser (SIOX)

- i) Type Calorimetric Analyzer (with auto reagent shut off feature in case of sample loss or power loss) built in phosphate inhibition feature. Micro processor based.
- ii) Case material : Die cast aluminum
- iii) Cycle time Twelve (12) minutes maximum
- iv) Analyser out put
 - a) 4 to 20m A DC recorder
 - b) 4 to 20m A DC Isolated output for DCS



-
- | | | |
|-------|-----------------------|---|
| v) | Power supply | 240V DC, 50Hz |
| vi) | Accuracy | ± 1% of span |
| vii) | Repeatability | ± 2% of full scale |
| viii) | Sensitivity | 0.2 micrograms / liters |
| ix) | Connection | |
| | i) Process | 1/4 inch NPT(F) SCRD. |
| | ii) Electrical | 1/2 inch NPT(F) SCRD |
| x) | Ranges | As per sample stream. |
| xi) | Mounting | Flush |
| xii) | Annunciation contacts | |
| | a) Number | 2 SPDT. |
| | b) Type | Snap action micro switch. |
| | c) Rating | 5 A 240V AC, 0.2 A 220V D.C. |
| xiii) | Accessories | |
| | a) | Chilling plant (if required) |
| | b) | Automatic temperature compensation between 5 deg.to 50deg C. |
| | c) | Automatic zeroing provision. |
| | d) | SS tubing & vessels. |
| | e) | All chemical reagents for 12 months operation of the analysers. |
| | f) | Sample rate set values. |
| | g) | Comprehensive diagnostic and alarm features. |

6.5.2.5 Hydrazine Analyser

- | | | |
|------|-----------------|------------------------|
| i) | Type | Electrochemical |
| ii) | Case material | Die-cast aluminum |
| iii) | Analyser output | 4-20mA DC for Recorder |

4-20 mA DC isolated output for DDCMIS



- iv) Power supply 240V AC, 50 Hz.
- v) Accuracy $\pm 2\%$ of full scale.
- vi) Sensitivity 1.0 microgram/litre.
- vii) Annunciation contacts
 - a) Number 2 SPDT
 - b) Type Snap action micro switch.
 - c) Rating 5A 240V AC, 220V D.C.
- viii) Mounting Flush mounting.
- ix) Accessories
 - a) Flow regulator.
 - b) Flow gauges.
 - c) Other accessories as required.
 - d) Sample rate set valves.
 - e) Chemical reagents as applicable for 12 months consumption.

6.5.2.6 Sodium Ion Analyser.

- i. Type Continuous flow through sample type with sodium responsive electrode and reference electrode having pH adjustment facility
- ii. Case material Die-cast aluminium
- iii. Analyser power supply 240V AC , 50 Hz.
- iv. Analyser output
 - a) 4-20mA DC for Recorder.
 - b) 4-20mA DC isolated output for DDCMIS.
- v. Accuracy Better than $\pm 5\%$ of full scale.
- vi. Sensitivity 0.1 ppb.
- vii. Annunciation contacts
 - a) Number 2 SPDT
 - b) Type Snap action micro switch.
 - c) Rating 5A 240V AC, 0.2A 220V DC.
- viii. Mounting Flush.



- ix. Accessories
- a) Flow regulator.
 - b) Flow gauges.
 - c) Sample rate set valves.
 - d) Other accessories as required to Make the system complete.

6.5.2.7 Chloride Analyser

- i. Type Continuous flow through sample type
- ii. Analyser power supply 240V AC, 50 Hz
- iii. Analyser output
- a) 4-20mA DC spare output.
 - b) 4-20mA DC isolated output for DDCMIS.
- iv. Accuracy Better than + 5 microgram/litre of full scale.
- v. Sensitivity 0.1 ppm.
- vi. Annunciation contacts:.
- a) Number 2 SPDT
 - b) Type Snap action micro switch.
 - c) Rating 5A, 240V, AC, 0.2A, 220V DC.
 - d) Mounting Flush.
- vii. Terminal points All component piped & wired.
- viii. Accessories
- a) Flow regulator.
 - b) Flow gauges.
 - c) Sample rate set valves.
 - d) Other accessories as required to make the system complete

6.5.3 System and type of measurement

All analysers, cells, monitors as offered shall be from field proven of international reputed make and subject to purchaser's approval. The bidder shall provide the on line analysis system for the following samples as a minimum but not limited to:



S.No.	System	Type of measurement
i)	Make-up D.M. water	a) Specific conductivity b) Cation conductivity
ii)	Hotwell Condensate	Specific conductivity (both sides)
iii)	C.E.P. Discharge	a) pH b) Cation conductivity c) Sodium ion d) Dissolved Oxygen e) Specific conductivity
iv)	Condensate polisher outlet	a) Specific conductivity b) Sodium ion c) Silica d) Cation conductivity e) pH.
v)	Deaerator outlet	Dissolved oxygen
vi)	Feedwater at economiser inlet	a) pH b) Specific conductivity, c) Cation conductivity d) Hydrazine e) Dissolved Oxygen
vii)	Boiler saturated steam	a) ph b) Specific conductivity c) Cation conductivity
viii)	Main steam -SH outlet	a) pH b) Specific conductivity c) Cation conductivity d) Sodium



- | | | | |
|-----|-------------------------|----|-----------------------|
| ix) | Drum | a) | pH |
| | | b) | Specific conductivity |
| | | c) | Silica |
| | | d) | Phosphate |
| | | e) | Chloride |
| x) | Condenser cooling water | a) | pH |
| | | b) | specific conductivity |

For hotwell conductivity measurement, the bidder shall provide direct insertion type/ withdrawable type conductivity cell whereas for all other samples it shall be flow-through type. Monitors for hotwell conductivity shall be suitable for field mounting.

6.5.4 Alarm Contacts

One set of alarm contacts of SPDT type shall be provided with each analyzer/monitor which shall be wired to the DDCMIS. Further, 4-20 mA signals from all analyzers shall be hooked up to DDCMIS for monitoring purposes as well as for control of hydrazine and ammonia dosing through CLCS.

6.5.5 General

Field proven monitors/analyzers based on microprocessors with LCD display and with necessary fault diagnostic features shall be employed. The type, size, capacity, material, make, model and other specification details of the rest of the SWAS system like coolers, gauges/switches, sample pipes, filter, pressure reducing elements, grab sampling arrangement valves & fittings, panels etc. shall be as decided during detailed engineering stage and shall be subject to Purchaser's approval. The power supply to all the analysers/monitors shall be supplied by the bidder from his UPS system with all necessary switches, fuses etc. for distribution to individual requirements.



6.6 UNIT CONTROL DESK, UNIT CONTROL PANEL, SYSTEM CABINETS, LOCAL PANELS & TRANSMITTERS ENCLOSURES/RACKS.

6.6.1 General

- i) All unit control desks, panels, system cabinets, local panels and local instrument enclosures, racks shall be furnished fully wired with necessary provision for convenience outlets, internal lighting, grounding, ventilation, space heating, anti-vibration pads, internal piping and accessories as per IS:5039-1969 as required for completeness of the system.
- ii) All panels, desks, cabinets shall be free standing type and have bottom entry for cables unless otherwise specified. The bottom of desks, panels, cabinets, enclosures shall be sealed with bottom plate, compression cable glands and fire proof sealing material to prevent ingress of dust and propagation of fire.
- iii) All electronic system cabinets shall be designed for 50 deg C operating under maximum ambient temperature without air conditioning system in service. Further cabinets, panels shall be so designed that temperature rise due to heat load does not exceed 10 deg. C above ambient temperature under all operating conditions. Necessary louvers, fans, limited packing density, adequate spacing between instruments, devices etc. shall be provided to maintain temperature rise within permissible limits.
- iv) Desk, panels, cabinets enclosures wiring and piping shall be arranged to enable the removal of instruments and devices without unduly disturbing them.
- v) All panels, desks, enclosures interiors shall be illuminated with rapid start fluorescent strip fixtures with door actuated switches. Door switch terminals shall be shrouded. All illuminated lights shall be provided with individual switch in parallel with door switch.
- vi) Sufficient number of power receptacles with disconnect switches shall be installed within panels, desks, enclosure and racks.
- vii) Bidder shall provide the unit control desk (UCD) and unit control panel (UCP) which will be mounted in the unit control rooms.
- viii) The local instrument enclosures/racks shall be provided locally for mounting of electronic transmitters and switches, etc.
- ix) All panels, desks, cabinets shall be properly grounded. The grounding scheme shall be as approved by the purchaser.
- x) Exterior steel surface shall be sand blasted, ground smooth, filled, primed, sanded and smooth enamel painted to give a good finish subject to minimum paint thickness of 65-75 microns for sheet thickness of 3 mm and 50 microns for sheet thickness of 2mm. Minimum 2 coats of primer and two sprays of final finish colour shall be applied to all surfaces.



- xi) The colour of the panels shall be brilliant white in the panel interior. External colour of the panels will be as RAL 7032 for UCB/ UCD, LIE/ LIR and other system cabinets, etc.
- xii) Due consideration shall be given to the ergonomics of unit control desks, unit control panels and the control room design. The design shall conform to the DIN 33414 (Ergonomical design of control room), Part-2 for cognitive factors and Part-4 for arrangement principles.

6.6.2 Control Desk and Panels

6.6.2.1 General

- i) The exact dimensions, material, construction details etc. of Control Desks, panels etc. shall be as per the actual requirement and shall be finalised during detailed engineering. The general arrangement of the desks, panels shall also be finalised during detailed engineering, subject to Purchaser's approval.
- ii) The design of all control panels shall take due regard of the actual application of various devices. It is important that controls and indications required by the operator for a particular operation should be grouped together.
- iii) The bidder must pay particular attention in the positioning of desk mounted TFT's in relation to control room lighting in order to minimise reflections.
- iv) For panels, desks mounted instruments/ devices, etc. which are to be powered from UPS, all required conversion of interface equipment, accessories to make such devices compatible with UPS supply shall be provided. All necessary hardware like input switches, fuse unit for each feeder as well as switch fuse unit for each instrument/ device on the power supply line shall be provided. From UPS, two feeders shall be provided alongwith suitably rated MCB and provision of fast auto changeover of UPS feeders. Power supply distribution scheme shall be as approved by the purchaser during detailed engineering stage.

6.6.2.2 Unit Control Desk (UCD)

Unit control desk shall be free standing table top type with doors at the back and shall be constructed of 3 mm thick CRCA steel plates. All operators TFTs & keyboards shall be mounted on this UCD. PA system hand sets, telephone sets and alarm annunciation PBs shall also be mounted. Very few auto-manual stations & PB stations and lamps may also be mounted on the control desk on mosaic grid structure if found necessary. The desk shall be arranged in an continuous arc shape. The exact profile of the desk, dimension and the radius of curvature shall also be finalised during detailed engineering stage.

To achieve durable and water resistant finish, a coat of "Polyuthesive crystal clear" on the surface of unit control desks shall be provided. Final paint finish with proper smoothing is to be ensured. Final finish of UCD should be in line with relevant International standards.



6.6.2.3 Unit Control Panel (UCP)

UCP shall be free standing vertical panel with double leaf hinged doors at the back. It shall be constructed of 3 mm thick CRCA steel plates with mosaic grid structure on front surface. The mosaic grid tiles shall be of 24 mm x 48 mm (or 25 mm x 50 mm) size, made of heat and flame retardant, self extinguishing and non-hygroscopic material with flat matt finish without glare and non reflecting type. The UCP shall also be arranged in a continuous arc shape. The profile and dimension i.e. radius of curvatures shall be decided during detailed engineering.

All conventional back up devices/instruments shall be provided on UCP. For mounting items like PB stations, miniaturised control switches, indicators, recorders, annunciation windows, on mosaic grid, the size of all these devices/instruments shall be compatible to mosaic grid on UCP.

The mosaic grid construction should be flexible enough to allow easy shifting at site of any instrument on mosaic grid (including indicators & recorders) to any other free location on the UCP without any need of cutting or special equipment/ tool.

6.6.2.4 The repeat annunciation for locally controlled systems like service air & instrument air compressors, DM water pumps etc. shall be provided on UCP. All required miniaturised control switches, electrical meters for achieving the control of station electrical system (circuit breaker etc.) shall be provided in the UCP of different units as applicable. The exact number & location of these shall be as finalised during detailed engineering state.

6.6.3 Cabinets, Enclosures, Panels

- i) Smoke detectors shall be provided inside the system cabinets.
- ii) The cabinets, panels shall be provided with eye bolts for lifting.
- iii) Feeder failure/ healthy indication shall be provided in each cabinet and remote indication shall be hooked up to DDCMIS/ annunciation and suitably grouped.
- iv) The dimensions and load of all panels, cabinets and enclosures shall be clearly brought out during detailed engineering.
- v) Sheet steel thickness for local panels, system cabinets shall not be less than 1.6 mm unless otherwise specified.
- vi) All panels, enclosures, system cabinets, marshalling cabinets shall be provided with a minimum of 20% spare terminations and system cabinets shall be provided with spare space for 20% additional modules fully wired with connectors etc. in excess of the total requirement of the system design when the cabinets are delivered. The spare space capacity shall be distributed evenly throughout the cabinets.



6.6.4 Local Instrument Enclosure and Racks

- i) Transmitters and switches, devices, etc. mounted in the field shall be suitably grouped together and mounted in local instruments enclosures in case of open areas of the plant like boiler area, etc. and in local instrument racks in case of covered areas like A-B bay. These local instrument enclosures and racks shall be furnished as per the actual requirements finalised during detailed engineering stage. The exact grouping of instruments in a particular instrument enclosure/instrument rack shall be as finalised during detailed engineering stage subject to the purchaser's approval.
- ii) The local instrument enclosures shall be constructed of 1.6 mm sheet plate and shall be of modular construction with one or more modules and two end assemblies bolted together to form an enclosure. Vibration dampeners shall be installed for supporting each enclosure. The internal layout shall be such that the impulse piping/ blowdown lines are accessible from back doors of the enclosure and the transmitters etc. are accessible from front side for easy maintenance. Gaskets shall be used between all mating sections to achieve protection class of IP-55.
- iii) The local instrument racks shall be free standing type constructed of suitable 3 mm thick channel frame of steel and shall be provided with a canopy to protect the equipment mounted in racks from falling objects, water etc. The canopy shall not be less than 3 mm thick steel, and extended beyond the ends of the rack. Bulk heads, especially designed to provide isolation from process line vibration shall be provided. Exact fabrication details shall be as finalised during detailed engineering stage. The junction box for racks also shall conform to IP 55 protection class.
- iv) Provision for continuous purging arrangement is to be made for all air and flue gas applications.



6.7 ELECTRIC POWER SUPPLY

6.7.1 General

The requirements of electric power supply system are specified herein on system basis. The contractor shall be fully responsible for engineering and furnishing a complete and operational system fully meeting the intent and requirements of this specification and purchaser approved drawings. All equipment and accessories required for completeness of this system shall be furnished by the contractor whether these are specifically mentioned herein or not. All the equipments and sub systems offered shall be from reputed experienced manufacturers. All system cabinets, enclosures and distribution boards shall be manufactured, assembled, wired and fully tested as a complete assembly as per the requirements of this specification at the manufacturer's works.

6.7.2 Power Supply Requirements

The power supply system shall be designed to meet the electric power requirements of various C&I systems including DDCMIS and shall be configured as described below:

- i) Three sets to meet the total DC load requirement each for SG-C&I system, TG-C&I system and for BOP-C&I and miscellaneous loads shall be provided.

Each of the above set shall comprise of 2x100% 24V DC batteries, 2x100% redundant chargers, 2 x 100% DC distribution boards etc. Bidder shall clearly bring out in the proposal the redundancy features along with necessary single line diagram, data sheets etc. and this shall be finalised during detailed engineering and subject to Purchaser's approval.

In case some other DC system (e.g. 48 V) is being supplied, similar configuration as described above for 24 V DC shall be provided.

- ii) For MMIPIS portion of DDCMIS including peripherals like TFT's, printers, disks etc. and other systems such as SWAS, panel instruments, vibration monitoring system, etc., requiring stabilised AC power, the Bidder shall furnish a redundant UPS system
- iii) For other SG/TG related instruments (clause 6.3), the power supply shall be derived from either the 24V DC or UPS as per specific requirement of the equipment supplier and as approved by Purchaser during detailed engineering.

The DC power supply system and UPS system in the above mentioned configurations employing float cum boost chargers, battery banks, static inverters, static switches. AC/DC distribution boards etc. shall meet the following specification requirements as a minimum.



6.7.3 DC Power Supply System (24 V)

6.7.3.1 Float cum boost chargers

- i) Each of the redundant chargers shall be sized to meet connected load requirements and keep the connected battery fully charged (float mode). In boost mode, each of the charger shall be able to re-charge the fully discharged battery within 8 hours. The exact sizing of the chargers shall be as approved by the purchaser during detailed engineering.
- ii) The chargers shall be self regulating, solid state silicon controlled, full-wave rectifier type designed for single and parallel operation with battery and shall have automatic voltage regulators for a close voltage stability even when AC supply voltage and DC load fluctuates, effective current limiting features and filters on both input and output to minimise harmonics. The charger output regulation shall be $\pm 1\%$ from no load to full load with an input power supply variation of $\pm 10\%$ in voltage and $\pm 5\%$ in frequency. In addition to indications on charger panel, potential free contacts for alarms like charger output voltage high, battery isolated, charger failed etc., shall also be provided for use in DDCMIS. Further isolated 4-20 mA signals shall be provided for important parameters like charger voltage etc. The list of alarm output and 4-20 mA signals shall be as approved by the purchaser during detailed engineering.
- iii) A selector switch "FLOAT/BOOST" mode shall be provided for either trickle charging the battery (while supplying the load) or boost charge the battery (isolated from load) respectively. In boost charging mode, the chargers shall operate in constant current mode building up the voltage across the battery to 1.6 V/ cell.

6.7.3.2 Batteries

The batteries shall be heavy duty Nickel-cadmium (Ni-cd) type and shall be sized for an hour of full load operation during non-availability of AC supply / chargers. The Ni-Cd batteries shall conform to IS:10918. For sizing calculation, an aging factor of 0.8 and a temperature correction factor of 0.935 (based on temperature characteristics curve to be submitted by the contractor and at a temperature of 4 deg. C). Capacity factor shall be taken into consideration, if applicable and ambient temperature shall be considered as the electrolytic temperature. The sizing of the battery shall be as approved by Purchaser during detailed engineering. However, bidder will consider a voltage drop of 4V from battery room to DCDB, while sizing the battery.

6.7.3.3 DC Distribution Board (DCDB)

Each of the connected load shall be supplied by redundant DC feeders. The exact design & number of feeders of the each redundant DCDB shall be as finalised during detailed engineering and as approved by the purchaser. However, 25% spare feeder (minimum one no.) with fuses for each rating shall be provided.



6.7.4 Uninterruptible Power Supply (UPS) System

The UPS system shall have 2x100% parallel redundant chargers and inverters, 1x100% battery bank, bypass line transformers and voltage stabiliser, static switch, manual bypass switch, AC/DC distribution boards, other necessary protective devices and accessories and shall meet the following requirements as a minimum.

6.7.4.1 The kVA rating of UPS shall be as required by expected loads and include 10% spare capacity guaranteed at 50 deg. C ambient. However, for bidding purpose, a minimum capacity of 90 KVA shall be considered. If UPS KVA rating is applicable at a lower ambient temperature than specified 50 deg. C, the Bidder shall consider a derating factor of at least 1.5%/deg.C for arriving at the specified UPS capacity at 50 deg. C ambient. The UPS shall have an over load capacity of 125 % rated capacity for 10 minutes and 150 % rated capacity for 10 seconds. The inverter shall have sufficient I^2t capability to clear fault in the maximum rated branch circuit. The sizing of UPS shall be based on the power factor of the loads being fed subject to a maximum of 0.8.

6.7.4.2 Each of the two sets of 2x100% redundant chargers shall be sized to meet the 100% UPS load plus recharge the fully discharged battery within 8 hours. Other features as mentioned in clause 6.7.3.1 above shall also be applicable.

6.7.4.3 The UPS battery shall have sufficient amp-hour capacity to supply 100% full load current of UPS for 60 minutes. For this, the UPS capacity to be considered as the finally selected UPS rating, irrespective of the actual load on UPS. A drop of 4V from battery room to the inverter input will be considered for design. The battery shall meet other specification requirements as per clause 6.7.3.2 above.

6.7.4.4 The UPS system shall be capable of operating without D.C. battery in circuit under all conditions of load and the performance of various components of UPS like inverter, charger, static switch etc. shall be guaranteed without the battery in circuit.

6.7.4.5 The UPS system design shall ensure that in case of failure of mains input power supply to one of the chargers, the other charger whose mains input power supply is healthy, shall feed to one or both the inverters as the case may be as per manufacturer's standard practice & continue to charge the D.C. battery at all load conditions. The Bidder should note that this situation should not in any way lead to the discharge of the D.C. Battery.

6.7.4.6 Static Inverters

- i) The static inverter shall be solid state type using proven pulse width modulation (PWM)/quasi square wave/step wave technique. The inverter equipment shall include all necessary circuitry and devices to conform to requirements like voltage regulation, current limiting, wave shaping, transient recovery, automatic synchronization etc. The steady state voltage regulation shall be $\pm 2\%$ and transient voltage regulation (on application/removal of 100% load) shall be $\pm 20\%$. Time to recover from transient to normal voltage



shall not be more than 50 m sec. Frequency regulation for all conditions of input supplies, loads and temperature occurring simultaneously or in any combination shall be better than $\pm 0.5\%$ (automatically controlled). The total harmonic content shall be 5% maximum and content of any single harmonic shall be 3% maximum. The inverter efficiency shall be at least 85% on full load and 80% on 50% load. The synchronisation limit for maintenance of synchronisation between the inverter and standby AC source shall be 48-52Hz, field adjustable in steps of 0.5 Hz.

- ii) The inverter shall be provided with suitable HRC fuses at the input and output which will permit proper coordination with other protective devices and at the same time protect the inverter against damage due to internal faults. However, if the Bidder's system design does not use fuses then the fuse free circuit breaker may also be permitted provided it meets the specification requirements. All necessary equipment shall be provided to protect the inverter against overload, short circuit and 100% loss of load. The inverter shall be self protecting against damage if energized with full load connected.
- iii) Inverter equipment shall include all solid state circuitry and devices including stable oscillator etc. to enable inverters to operate satisfactorily in parallel sharing mode each inverter taking 50% load during normal operation. In case of failure of either inverter, 100% load shall automatically be transferred to healthy inverter without any break and degradation in the quality of UPS output and disconnecting the faulty inverter automatically.
- iv) The inverter failure shall be alarmed and the healthy inverter shall get synchronizing signal from the standby AC source and remain synchronized within the set limits. The limits for the synchronisation between healthy inverter and standby AC source shall be field adjustable.
- v) On failure of both inverters, the loads shall be transferred to standby AC power without a break if within synchronisation limits. However, such transfer shall be inhibited, during operation of inverter on its internal oscillator, to standby AC source frequency being beyond the synchronisation limits. Provision of asynchronous transfer with a break in case of inverter being out of synchronisation limits shall also be there with standby source.

6.7.4.7 **Static Switch and Manual Bypass Switch**

The static switch shall be provided to perform the function of transferring UPS loads automatically without any break from (i) faulty inverter to standby AC source in case of failure of both the inverters and (ii) from faulty inverter to standby AC source in case of failure of both the inverters.

Manual bypass switch shall be employed for isolating the UPS during maintenance.

6.7.4.8 **Step Down Transformer and Voltage Stabiliser**

The transformer shall be of low impedance type and the rating shall be such that extremely fast fault clearance is achieved even in the largest rated branch circuit.



The overload capacity of the transformer/stabilizer shall not be less than 300% for 200 ms. The stabilizer shall employ silicon solid state circuitry and the output voltage regulation shall be $\pm 2\%$. The efficiency of the stabiliser shall be 95% or better.

6.7.4.9 AC Distribution Board (ACDB)

The details of the AC distribution board, i.e. exact design, number of feeders etc of the 2x100% ACDB shall be as finalised during detailed engineering and as approved by the purchaser. However, 25% spare feeders (minimum one no.) with fuses for each rating shall be provided.

6.7.5 Auxiliary Equipments

- i) All required auxiliary equipment/materials as finalised during detailed engineering shall be furnished with each charger, inverter, battery bank and shall include as a minimum various meters such as AC/DC voltage/current, kVA, power factor, frequency meters etc., circuit breakers, selector switches, push buttons indicating lights, ground detector system, battery accessories like inter cell connectors, inter step connectors, battery racks etc.. Further, isolated 4-20 mA signals for important parameters and potential free contacts for important alarms shall be provided for use in DDCMIS.
- ii) One complete set of all accessories and devices required for maintenance and testing of batteries shall be supplied for each unit. Each set shall include at least the following :

a)	Hydrometer	5 Nos.
b)	Set of hydrometer syringes suitable for the vent holes in different cells	5 Nos.
c)	Thermometer for measuring electrolyte temperature	5 Nos.
d)	Specific gravity correction chart	5 Nos.
e)	Wall mounting type holder made of teak wood for hydrometer & thermometer	5 Nos.
f)	Cell testing voltmeter (3-0-3 V)	5 Nos.
g)	Alkali mixing jar	5 Nos.
h)	Rubber apron	5 Nos.
i)	Pair of rubber gloves	5 Nos.
j)	Set of spanners	5 Nos.



k)	No smoking notice for each battery room	2 Nos.
l)	Goggles (industrial)	5 Nos.
m)	Instruction card	10 Nos.
n)	Minimum and maximum temperature indicator for battery room	1 set
o)	Cell lifting facility	1 No.

6.7.6 Battery Racks

Two tier battery racks made of steel and painted with anti- corrosive epoxy paint construction in accordance with applicable codes and standard shall be provided. AISC specification shall apply in the absence of another design specification.

6.7.7 Load End Power Supply Distribution

Bidder shall provide power supply distribution boxes for sub-distribution of main UPS/ DC/ Utility feeder(s). These shall include necessary change over circuitry (if applicable), switch-fuse units, MCB, terminal blocks etc. suitable for the application.

Bidder shall furnish the power supply distribution scheme, single line diagram, all calculations such as charger/inverter rating calculations, battery sizing calculation etc., for DC system as well as for UPS during detailed engineering for Purchaser's review and approval.



6.8 ELECTRICAL ACTUATORS

Electrical actuators provided for valves and dampers shall meet with following requirements.

6.8.1 Type

- i) The actuators shall have integral starters alongwith overload relays with built in SPP (single phasing preventer). A 415, 3 phase 3 wire power supply shall be given to the actuator from contractor's switch board through a switch fuse unit. Control voltage of the motor starter shall be 110 V AC / 24 V DC, derived suitably from 415V power supply.
- ii) In case supplier's standard control voltage for open/close contactors is 110V AC, the same is acceptable if suitable opto - isolation circuit is provided with coupling relays for 24 V DC command inputs.

6.8.2 Interfaces

Open/close command termination logic with position and torque limit switches, positioner circuit shall be suitably built in the PCB inside the actuator.

- (a) For binary drive, open/close command and status thereof and disturbance monitoring signal (common contact for overload, thermostat, control supply failure, L/R selector switch at local, other protections operated) shall be provided.

Interface with the control system shall be through hardwired signal only. Interposing relays provided (with coil burden 2.5 VA) in the actuator shall be energized to initiate opening and closing, by 24V DC signal from the external control system.

- (b) For modulating drive, the command to actuator shall be in form of 4-20mA signal. The necessary positioning circuit and motor protection shall be provided
- (c) Open/close command termination logic shall be suitably built inside actuator.

6.8.3 Rating

- (a) Supply voltage & frequency: 415V +/- 10%, 3- phase, 3 wire 50Hz +/-5%.
- (b) Sizing for open/close at rated speed against designed differential pressure at 90% of rated voltage.



- (c) For isolating service, three successive open-close operations or 15 mins, whichever is higher. For regulating service, 150 starts per hour or required cycles, whichever is higher.

6.8.4 **Construction**

- a) Enclosures shall be totally enclosed weatherproof minimum IP-55 degree of protection
- b) Gear Train shall be made of metal (Fibre gears are not acceptable). Self-locking feature shall be provided to prevent drift under torque switch (where ever applicable) spring pressure when motor is de-energised.
- c) Manual wheel shall disengage automatically during motor operation.

6.8.5 **Motor**

- (a) Type
Squirrel cage induction motor, direct-on-line starting with starting current limited to six times the rated current.
- (b) Enclosure
Totally enclosed, self ventilated IP-55 degree of protection.
- (c) Insulation
Class B or better. Temperature rise 70 Deg C. over 50 Deg C ambient
- (d) Bearings
Double shielded, grease lubricated antifriction.
- (e) Earth Terminals
Two
- (f) Protection
Single phasing protection, overload protection, overheating protection through thermostat and wrong phase sequence protection shall be provided over and above other protection features standard to bidder's design. Suitable means shall be provided to diagnose the type of fault locally.

- 6.8.6 Four nos. (2 each in open and close position) position limit switches and two nos. (one in open and other in close direction) torque switches each having two nos. NO and two nos. NC contacts shall be provided. A single shaft shall actuate all contacts of limit switches at each position.



- 6.8.7 It shall be possible to operate the actuator locally also. Lockable local/remote selection shall be provided on the actuator
- 6.8.8 Position Indicator shall be provided for 0 to 100% travel
- 6.8.9 Position Transmitter (for modulating/inching type) shall be provided as required it shall be suitable for stabilized 4-20 mA signal, 2 wire inductive type, 24 volts DC operated.
- 6.8.10 Space heater of suitable rating shall be provided. The supply shall be derived from the main power supply available in the actuator



6.9 PROCESS CONNECTION PIPING

The bidder shall provide, install and test all required material for completeness of impulse piping system, sample piping system and air piping system as per the requirements of this clause on as required basis for the connection of instruments and control equipment to the process and make the system complete. However, the bidder shall furnish during detailed engineering all relevant drawings, material and technical specifications of various items service wise for Purchaser's approval.

All materials supplied shall be suitable for intended service, process, operating conditions and type of instruments used and shall fully conform to the requirements of this specification. The material offered by the bidder shall be from reputed, proven manufacturer.

6.9.1 Impulse Piping, Tubing, Fittings, Valves and Valve Manifolds

- i) All impulse pipes shall be of seamless type conforming to ANSI B36.10 for schedule numbers, sizes and dimensions etc. The material of the impulse pipe shall be same as that of main process pipe. For various applications specification of impulse pipe materials and associated fittings and valves shall be as given in Table –9.1 (Process Connection Piping) given at the end of this sub-section.
- ii) Stainless steel tube shall be provided inside enclosures and racks from tee connection to valve manifold and then to instrument. For high pressure/temperature applications (piping class A,B,C &D of the Table 9.1) the material shall be ASTM A 213 TP 316H and for other applications material shall be ASTM A 213 TP 316L. The wall thickness of the tube shall be in accordance with the ANSI B31.1 standard.
- iii) All fittings shall be forged steel and shall conform to ANSI B16.11. The material of forged tube fittings for shaped application (e.g. tee, elbow etc.) shall be ASTM A182 Gr. 316 H for high pressure/ temperature applications (as defined above) and ASTM A182 Gr. 316L for other applications. The material for bar stock tube fitting (for straight application) shall be 316 SS. Metal thickness in the fittings shall be adequate to provide actual bursting strength equal to or greater than those of the impulse pipe or SS tube, with which they are to be used.
- iv) The source shut-off (primary process root valve) and blow down valve shall be of 1/2 inch size globe valve type for all applications except for air and flue gas service wherein the source shut-off valve shall be 3/4 inch size gate valve to avoid frequent chocking. The disc and seat ring materials of carbon steel and alloy steel valves shall be ASTM A-105 and ASTM A-182, Gr. F22, hard faced with stellite (minimum hardness - 350 BHN.) The surface finish of 16 RMS or greater is required in the area of stem packing. The valve design shall be such that the seats can be re-conditioned and stem and disc may be replaced without removing the valve body from the line.



- v) The valve manifolds shall be of 316 stainless steel with pressure rating suitable for intended application. 2 valve manifold and 3 valve manifold shall be used for pressure measurements using pressure transmitters/ pressure switches and differential pressure transmitters/ switches respectively. 5 valve manifold shall be used for remaining applications like DP, flow and level measurements.

For Pressure/D.P gauges in fluid application two-way globe valve on each impulse line to the instrument and in air/flue gas application two way gate valve on each impulse line to the instrument shall be provided near the instrument. These shall be in addition to the three way gauge cock provided alongwith the pressure/D.P gauges.

6.9.2 Sample Piping System

- i) This shall include pipings, fittings, valves and accessories from tapping points upto SWAS conditioning panel located in SWAS room. All sample pipings shall be 3/4" Nb seamless type of material ASTM A213 TP 316 H, conforming to ANSI B36.19. The schedule number shall be suitable for the particular application.
- ii) All fittings shall be socket welding type and of material ASTM A182 F316H conforming to ANSI B 16.11.
- iii) Single and multi tubes shall run with the minimum number of changes in direction. Suitable identification tags shall be provided for easy check up and for proper connections.
- iv) The valves to be used in sample piping shall be of globe type, forged construction and stainless steel conforming to ASTM A182. The pressure and temperature ratings shall be as per ANSI B16.34. The valve design shall be such that the seats can be re-conditioned and stem and disc can be replaced without removing valve body from the line.

6.9.3 Air Supply Piping

- i) All pneumatic piping, fittings, valves, air filter cum regulator and other accessories required for instrument air for the various pneumatic devices/ instruments shall be provided.

This will include as a minimum air supply to pneumatically operated control valves, actuators, instruments, continuous and intermittent purging requirements of Local Instrument Enclosures (LIE) etc.

- ii) For individual supply line and control signal line to control valve, 1/4 inch size light drawn tempered copper tubing conforming to ASTM B75 shall be used. The thickness of copper tubing shall not be less than 0.065 inch and shall be PVC coated. The fittings to be used with copper tubes shall be of cast brass, screwed type.



- iii) All other air supply lines of 1/2 inch to 2 inch shall be of carbon steel hot dipped galvanized inside and outside as per IS-1239, heavy duty with threaded ends. The threads shall be as per ASA B.2.1. Fittings material shall be of forged carbon steel A234 Gr. WPB galvanized inside and outside, screwed as per ASA B2.1. Dimensions of fittings shall be as per ASA B16.11 of rating 3000 lbs.
- iv) For air supply to various devices mentioned above, the bidder shall provide 2 nos., 2 inch size GI pipe header with isolation valve, one for boiler area and one for turbine area. In the boiler area the 2 inch head shall be provided upto top most elevation of boiler floor and from this 2 inch header, 1 inch sub-header shall be branched off at each floor with isolation valve. From this 1 inch sub-header, branch line of 1/2 inch, with isolation valve shall be provided upto various devices. Similar air supply piping shall be done in the turbine area also. Similar system is to be followed for service air required for intermittent purging in the Local Instrument Enclosures (LIEs) etc.
- v) Instrument air filter cum regulator set with mounting accessories shall be provided for each pneumatic device requiring air supply. The filter regulators shall be suitable for 10 kg/ sq.cm max. inlet pressure. The filter shall be of size 5 microns and of material sintered bronze. The air set shall have 2 inch size pressure gauge and built in filter housing blowdown valve. The end connection shall be as per the requirement to be finalised during detailed engineering.
- vi) All the isolation valves in the air supply line shall be gate valves as per ASTM B62 inside screw rising stem, screwed female ends as per ASA B2.1. Valve bonnet shall be union type & trim material shall be stainless steel, body rating 150 pounds ASA. The valve sizes shall be 1/2 inch to 2 inch.
- vii) **Purge Air Connection for Air and Flue Gas Applications**
 - a) The continuous purging with instrument air shall be done, for all air and flue gas measurements excepting instrument air and service air instruments, at the process source connection end. Necessary arrangements required for continuous purging shall be provided inside all the air and flue gas enclosures.
 - b) For intermittent purging with service air, necessary arrangements inside all the air and flue gas enclosures shall be provided. The SS three way valve provided in the SS tubing shall be used for isolating the transmitter and connecting the service air quick disconnect line.

6.9.4 Installation and Routing

6.9.4.1 Instrument Piping System

- i) For steam and liquid measurements, the impulse pipe should preferably slope downwards from source connection to instrument and instrument shall be installed below the source point. If due to any reason instrument is installed



above the source point, the impulse pipe should slope upwards continuously and a 'pigtail' should be provided at the instrument to assure a water seal for temperature protection. For vacuum measurements instrument shall be installed above source point and impulse pipe should slope upwards.

- ii) Impulse piping for air and flue gas shall slope upwards and instrument shall be installed above source point. If this requirement cannot be met special venting or drain provision shall be provided with vent and drain lines alongwith isolation valves and other accessories including drain pipes. This drain is to be connected to plant drain through open funnel also.
- iii) All impulse piping shall be installed to permit free movement due to thermal expansion. Wherever required expansion loops shall be provided. Expansion joints shall be provided wherever required especially for impulse piping coming in the furnace area.
- iv) Special accessories such as condensing pots/ reservoirs shall be provided and installed wherever required. In any case condensing pots shall be provided for all level measurements in steam and water services, all flow measurement in steam services and flow measurements in water services above 120°C. For drum level measurement required balancing chamber shall be provided.
- v) Colour coding of all impulse pipes shall be done by the bidder in line with the colour coding being followed for the parent pipes.

6.9.4.2 **Instrument Air & Service Air Piping/ Tubing System**

Instrument air and service air headers and their branches with all associated fittings and accessories shall be provided for giving supply to all consumers, as per the requirements. Air piping shall be installed always with a slope of over 1/100 to prevent accumulation of water within the pipe.

Single and multi tubes shall run with the minimum number of changes in direction. Suitable identification tags shall be provided for easy checkup and for connections.

6.9.5 **Piping/ Tubing Support**

Impulse piping and sample piping shall be supported at an interval not exceeding 1.5 meters. Each pipe shall be supported individually using slotted angle mounted clamps with necessary fixtures. Tubing shall run in proper perforated trays with proper cover. Tubing shall be supported inside the trays by aluminium supports. Hangers and other fixtures required for support of piping and trays shall be provided, either by welding or by bolting on walls, ceilings and structures. Hanger clamps and other fastening hardware shall be of corrosion resistant metals and hot-dip galvanized.



6.9.6 Shop and Site Tests

i) General Requirements

The equipment and work performed shall be subject to shop and site test as per Owner's approved quality assurance plan.

Hydrostatic and pneumatic tests shall be performed on all pipes, tubings and systems and shall conform to ANSI B31.1.

ii) Hydrostatic Testing

All instrument piping/ tubing shall be hydrostatically tested upon completion of erection. The test pressure shall be 1.5 times the maximum process pressure. The test shall be performed either with the testing of associated process piping or without the associated process piping (by closing the root valve. In both the cases the instrument shall be isolated by closing the shut-off valve).

iii) Air Testing

All air headers & branch pipes shall be air tested by pressure decay method as per ANSI B31.1. Flexible hoses and short signal tubing shall be tested at normal pressure for leakage. Long signal tubing shall be tested by charging each tube with air at 2 kg/ sq. cm. through a bubbler sight glass. The boiler draft and vacuum piping shall be air tested by the same method as long signal tubing.



TABLE 6.9.1 Process Connection Piping

<u>S.No.</u>	<u>System/Line Description</u>	<u>Piping Class</u>	<u>Impulse Pipe Material</u>	<u>Schedule (Size)</u>	<u>Materials for Fitting/Valve Body</u>	<u>Valve Stem Material</u>	<u>Rating of Piping/ Fittings</u>	<u>Pr. Class of Valve</u>
i)	Main steam/ upstream of HP bypass and auxiliary steam pressure reducing valve	A	ASTM-A335 Gr.P-91/22 (Note-2)	XXS (1/2 inch)	(Note-3)	(Note-3)	9000 lb	3000 SPL
ii)	BFP discharge/superheater attemperator/ spray to PRDS	B	ASTM-A106 Gr.C	160 (1/2 inch)	ASTM-A105	ASTM-A-182 Gr.F6a	6000 lb	2500
iii)	Reheater attemperator	C	ASTM-A106 Gr.C	160 (1/2 inch)	ASTM-A105	-do-	6000 lb	1500
iv)	Hot reheat/ down stream of aux. steam press. reducing valve upto desuper heater/ Flash tank drain manifold.	D	ASTM-A335 Gr.P-91/22 (Note-2)	160 (1/2 inch)	ASTM-A182 Gr.F-22	(Note-3)	3000 lb	900
v)	Cold reheat upto tee-off for HP bypass / extraction steam No. 5 to HPH	E	ASTM-A335 Gr.P-22	80 (1/2 inch)	ASTM-A182 Gr.F-22	ASTM-A-182 Gr.F6a	3000 lb	800
vi)	Cold reheat down steam of tee-off (HP Bypass)	F	ASTM-A106 Gr.C	80 (1/2 inch)	ASTM-A105	-do-	3000 lb	800
vii)	BFP suction/ condensate system/ extraction to LPH/ ext-4 to BFP-T, deaerator/ auxiliary steam	G	ASTM-A106 Gr.B	80 (1/2 inch)	ASTM-A105	-do-	3000 lb	800



Standard Technical Specification for Sub- critical Thermal Power Project - 2x(500MW or above)
Main Plant Package

Section 6 (Control and Instrumentation Works)

viii)	Air/ flue gas outside furnace	M	ASTM-A106 Gr.B/C	80 (3/4 inch)	ASTM-A105	-do-	3000 lb	800
	Air/ flue gas inside furnace	N	ASTM-A335 Gr.P22	80 (3/4 inch)	ASTM-A182 Gr. F-22	-do-	3000 lb	800

NOTE:

- 1 Rating of piping/fittings/valves etc. is subjected to the final design pressure & temperature during the detailed engineering.
- 2 In case temperature is more than 540 deg C, the material shall be P-91 only.
- 3 Material shall be compatible with that of the impulse pipe material and design parameter.



6.10 INSTRUMENTATION CABLES

6.10.1 General Requirements

- i) The bidder shall supply, erect, terminate and test all instrumentation cables for control and instrumentation equipment/devices/systems included under bidder's scope-
- ii) Any other application where it is felt that instrumentation cables are required due to system/operating condition requirements, are also to be provided by the bidder.
- iii) Other type of cables like co-axial cables for system bus, cables for connection of peripherals etc. (under Bidder's scope) are also to be furnished by the Bidder.
- iv) Bidder shall supply all cable erection and laying hardware like cable trays, supports, flexible conduits, cable glands, lugs, pull boxes etc. on as required basis for all the systems covered under this specification.
- v) In addition to above, bidder shall supply all the cables including co-axial cables for station Wide LAN interconnecting all the common plant, main plant & control system in Bidder's scope as well as the control systems supplied by Purchaser for DM plant, coal handling plant, ash handling plant and ash water recirculation system etc. Further, the instrumentation cables for interconnecting few nos. information signals from each of the common plant packages being supplied by purchaser for all signals of CW pump package to DDCMIS are also in the scope of bidder.

6.10.2 Instrumentation Cable Specifications

- 6.10.2.1 All the instrumentation cables i.e. twisted and shielded multipair cables, compensating cables, pre fabricated cables etc. shall be flame retardant low smoke (FRLS) type. The Cables shall be provided in non returnable drums. The drum length shall be 1000m (+/-5%) up to & including 8 pairs and 500 m (+/- 5%) above 8 pairs.
- 6.10.2.2 Voltage grade of the instrumentation cables shall be 225V (peak value).
- 6.10.2.3 All instrumentation cables covered in this specification shall comply with VDE 0815, VDE 0207, Part 4, Part 5, Part 6, VDE 0816, VDE 0472, SEN 4241475, ANSI MC 96.1, IS-8784, IS-10810 (latest editions) and its amendments read alongwith this specification.
- 6.10.2.4 The conductor shall be of minimum 0.5 sq.mm size, high conductivity, multi-stranded copper for all types of instrumentation cables .
- 6.10.2.5 The insulation of individual conductor shall be extruded PVC meeting the requirements of VDE 0207 Part 4 compound Y I3. The outer sheath of instrumentation cables shall be extruded PVC (compound YM1) as per VDE



0207 Part 5 and shall be of flame retardant low smoke (FRLS) type. The cable shall be provided with marking including manufacturer's name, insulation material, conductor size, no of pairs, voltage ratings, type of cable etc. Progressive sequential marking of the length of the cable at every one meter & progressive markings to read 'FRLS' at every 5 meters shall be provided on the outer sheath of all instrumentation cables. Pairs of Cables shall be identified by colour coding & colour banding. The colour of outer sheath shall be sky blue so that C&I cables are easily distinguished from other cables.

Fillers in multiple conductor cables shall be flame retardant and moisture resistant. Cable accessories such as harnessing components, markers, bedding, cable jointer, binding tape etc. shall also have flame retardant quality.

6.10.2.6 All instrumentation cables shall be provided with overall shielding. However multipair cables carrying analog signals shall be provided with individual pair shielding in addition to overall shielding. Shielding shall be of Aluminium-Mylar tape with 100% coverage and with atleast 20% overlapping. The thickness of individual pair shield shall be 28 micron (minimum) and that of overall shield shall be 55 microns (minimum). Separate drain wires for individual pair shield (wherever applicable) as well as overall shield shall be provided. Drain wire shall be of seven (7) strand 20 AWG (0.51 sq. mm) tin coated copper conductor. Maximum lay of individual twisted pair shall be 50 mm. Bidder to ensure that individual core diameter shall be suitable for maxi-termi connection. Insulation thickness of individual core shall be between 0.28 and 0.35 mm for 0.5 mm² cables and 0.35 to 0.45 mm for 1.31 mm² cables.

6.10.2.7 The outer sheath of the instrumentation cables shall meet the following minimum requirements:

- (i) An oxygen index of not less than 29% and a temperature index of not less than 250 deg. C as per ASTM-D-2863.
- (ii) Maximum acid gas generation by weight as per IEC-754-I shall not be more than 20%.
- (iii) Smoke density rating shall not be more than 60% during smoke density test as per ASTM-D-2843. The results of smoke density test shall be plotted on a curve indicating light absorption v/s time as per ASTM-D 2843. The average area under the curve (smoke density rating) shall not be more than 60%.
- (iv) Complete cable assembly shall pass Swedish Chimney test as per SEN-4241475 and flammability test as per IEEE-383.

The thickness of outer sheath shall be as per the guidelines given in VDE 0816. Thickness of outer sheath shall not be less than 1.8 mm in any case. Allowable tolerance of overall diameter of the cables shall be +/-2 mm max.



over the declared value in technical data sheets. The variation in diameter and the ovality at any cross section shall not be more than 0.1 mm.

- 6.10.2.8 All instrumentation cables shall be suitable for continuous operation at 70 deg. C, except for high temperature resistant teflon insulated cables which shall be suitable for continuous operation at 205 deg. C. The cables shall be suitable for laying in wet or dry locations in trays, conduits, ducts, trenches and under ground buried installations.
- 6.10.2.9 The thermocouple extension cables shall be of single/multi pair, twisted & shielded, PVC insulated, FRLS PVC sheathed and compatible for the type of thermocouples employed. The material of conductor shall be as per ANSI MC-96.1.
- 6.10.2.10 All cables near high temperature zone like burner front devices, metal temperature thermo-couples on main steam & turbine casing etc. shall be high temp cables, which shall be terminated at a junction box in normal temperature zone. Thermocouple extension cables and copper conductor cables for high temperature applications shall be with insulation of individual conductor and outer sheath of extruded FEP (i.e., Teflon) as per VDE 0207 Part 6 and ASTM D 2116. The thickness of insulation shall be 0.5 mm nominal (i.e., 0.4 mm minimum). These cables shall be single/ multipair, twisted & shielded.
- 6.10.2.11 Cable parameters such as mutual capacitance between conductors, conductor resistance, insulation resistance, characteristic impedance, cross talk and attenuation figures at 20 deg. C (± 3 deg. C) for various types of cables as applicable shall be as specified under table 10.1.
- 6.10.2.12 Identification of the cores & pairs shall be done with suitable colour coding & band marking as well as by numbering of cores/pairs as per VDE: 0815. The details of colour coding etc. shall be as approved by Purchaser during detailed stage. Also refer table 10.2 for description of various type of cables.
- 6.10.2.13 The bidder shall furnish all documentary evidence including cross-sectional drawings, test certificates to substantiate the suitability of cables offered for different applications. The bidder shall also clearly bring out the application wise details for each type of cable offered.
- 6.10.2.14 All prefabricated cables shall have 10% spare cores which will not be connected to pin connectors.



TABLE- 6.10.1: CABLE PARAMETERS

Conductor Size		0.5 sq.mm			
Parameter/Type	Type E,F	Type-G, I	Type A,B&C		
(a)	Mutual capacitance at 0.8 kHz (max.)	120 nF/Km.	100 nF/Km.	120 nF/Km.	200nF/ Km.
(b)	Conductor Resistance (max.)	73.4 ohm/km (loop) For Type F, 13.3 ohm/km (loop) for Type E	73.4 ohm/km (loop)	73.4 ohm/km (loop)	--
(c)	Insulation Resistance (min.)	100 M ohm/km	100 M ohm/km	100 M ohm/km	100 M ohm/km
(d)	Cross-talk figure at 0.8 kHz (min.)	60 dB	60 dB	60 dB	60 dB
(e)	Characteristic impedance (max.) at 1 kHz	320 ohm	340 ohm	320 ohm	--
(f)	Attenuation at 1 kHz (max.)	1.2 dB/Km for Type F 0.8 dN/Km For Type E	1.2 dB/Km	1.2 dB/Km	--



TABLE- 6.10.2

DESCRIPTION OF VARIOUS TYPES OF CABLES

Type	Conductor size in sq. mm	Remark
A	0.5	Two pair shielded and twisted pair thermo-couple, extension cable, ANSI type KX, solid alloy conductor.
B	0.5	Two pair shielded & twisted thermo-couple, extension cable ANSI type SX, solid alloy conductor.
C	0.5	Two pair shielded & twisted heat resistant teflon insulation & outersheath thermo-couple extension cable ANSI type KX, solid alloy conductor.
E	0.5	Two pair individual pair and overall shielded twisted pair instrumentation cable for both analog and digital signal to be used from field mounted instruments to local junction box.
F	0.5	Multipair individual pair & overall shielded twisted pair instrumentation cable (4/8/12/ 36/48 pair) for analog signals with stranded copper conductor.
G	0.5	Multipair overall shielded & twisted pair instrumentation cable (4/8/12/ 24/48/64 pair) for binary signals with stranded copper conductor.
I	0.5	Type F cable/type G cable with heat resistant teflon insulation & outersheath for high temperature application.
S	As per specific standard/ requirement for each application	Multicore/ multipair shielded cable for system specific cables like conductivity type level, switches, system bus cable, flame scanner etc. as applicable.

6.10.3 Instrumentation Cable Interconnection and Termination Philosophy

6.10.3.1 The cable interconnection philosophy to be adopted shall be such that extensive grouping of signals by large scale use of field mounted Group JBs



at strategic locations (where large concentration of signals are available, e.g. switchgear) is done and consequently cable with higher number of pairs are extensively used. JB's to be furnished under this specification shall be of 6/12/24/36/48/64/72/96/128/256 way. The material dimension and interior/ exterior colour of JB's shall be subject to Purchaser's approval. The details of termination to be followed is mentioned in the following table

TABLE- 6.10.3 :- CABLE TERMINATION TO BE FOLLOWED

S.N.	APPLICATION		TYPE OF TERMINATION		TYPE OF CABLE
	FROM (A)	TO (B)	END A	END B	
1	Valves/dampers drives (Integral Junction box)	Marshalling cubicle/local group JB/ termination/ control cabinets/ system cabinets	Plug in connector	Post mounted Maxi termi/ cage clamp type.	G
2	Transmitters, Process actuated switches to be mounted in LIE/LIR	Integral Junction box of LIE/LIR	Plug in connector	Maxi termi/ cage clamp (Rail mounted) type.	F,G
3	RTD heads	Local junction box	Plug in connector	Maxitermi/ cage clamp (Rail mounted) type.	F
4	Thermocouples	CJC box	Manufacture 's	Screwed/cage clamp Type	A,B,C*
5	Local Junction box, CJC box, int. Junction box of LIE/ LIR/Group JB/ MCC/Swgr.	Marshalling cubicle/local group JB/termination/ control cabinets/system cabinets	Maxitermi/ cage clamp (Rail mounted) type.	Post moun ted Maxi termi/ cage clamp type.	F,G
6	Local Junction box, MCC/swgr.	Group JB	Maxitermi/ cage clamp (Rail moun ted) type.	Maxitermi/ cage clamp (Rail moun ted) type.	F,G
7	Field mounted Instrument	Group JB	Maxitermi/ cage clamp (Rail moun ted) type.	Maxitermi/ca ge clamp (Rail moun ted) type.	F,G



Section 6 (Control and Instrumentation Works)

8	Marshalling cubicle/ termination cabinet	Electronic system cabinet		Post mounted Maxi termi/cage clamp type.	Post mounted Maxi termi/cage clamp type.	F,G
9	UCP mounted equipments	Post mounted Maxi termi/cage clamp type		Post mounted Maxi termi/cage clamp type.	Plug in connector/Cage clamp type (rail mounted).	F,G (with connector at one end)
10	DDCMIS/PLC cabinets	PC, Printers etc.		Plug in connector	Plug in connector	Manufacturer Standard

Notes:

1. For Sl. No. 5, 6, 7 & 8, normally 10% spare core shall be provided
2. For analog signals individual pair shielding & overall shielding & for binary signals only overall shielding of instrumentation cables shall be provided.
3. *For high temperature application only.



6.10.4 Internal Panels/Cabinets/System Cabinets Wiring

- i) Internal panel/cabinet wiring shall be of multistranded copper conductor with FRLS PVC insulation without shield and outer sheath meeting the requirements of VDE 0815.
- ii) Wiring to door mounted devices shall be done by 19 strand copper wire provided with adequate loop lengths of hinge wire so that multiple door opening shall not cause fatigue breaking of the conductor.
- iii) All internal wires shall be provided with tag and identification nos. etched on tightly fitted ferrules at both ends in purchaser's approved format. All wires directly connected to trip devices shall be distinguished by one additional red colour ferrule.
- iv) All external connections shall be made with one wire per termination point. Wires shall not be tapped or spliced between terminal points.
- v) All floor slots of desk/panels/cabinets used for cable entrance shall be provided with removable gasketed gland plates and sealing material. Split type grommets shall be used for prefabricated cables.
- vi) All the special tools as may be required for solderless connections shall be provided by Bidder.
- vii) Wire sizes to be utilised for internal wiring.
 - (a) Current (4-20 mA) : 0.5 sq.mm.
low voltage signals (48V)
 - (b) Ammeter/voltmeter circuit, : 1.5 sq.mm.
control switches etc. for
electrical system.
 - (c) Power supply and internal : 2.5 sq.mm.
minimum illumination
(shall be as per load
requirement.)

6.10.5 Cable Installation and Routing

- i) All cables assigned to a particular duct/conduit shall be grouped and pulled in simultaneously using cable grips and suitable lubricants. Cables removed from one duct/conduit shall not be reused without approval of Purchaser.
- ii) Cables shall be segregated as per IEEE Std.-422. In vertically stacked trays, the higher voltage cable shall be in higher position and instrumentation cable shall be in bottom tier of the tray stack. The distance between instrumentation cables and those of other systems shall be as follows :



- a) from 11 kV/6.6 kV/3.3 kV tray system - 914 mm
 - b) from 415V tray system - 610 mm
 - c) from control cable tray system - 305 mm
- iii) Cables shall terminate in the enclosure through cable glands. All cable glands shall be properly gasketed. Fire proof sealing to prevent dust entry and propagation of fire shall be provided for all floor slots used for cable entrance.
- iv) All cables shall be identified by tag nos. provided in Purchaser's approved format at both the ends as well as at an interval of 5 meters.
- v) Line voltage drop due to high resistance splices, terminal contacts, insulation resistance at terminal block, very long transmission line etc. shall be reduced as far as practicable.
- vi) The cables emanating from redundant equipment/devices shall be routed through different routes.

6.10.6 Cable Accessories and Fittings

- i) Bidder shall supply and install all cable accessories and fittings like cable glands, grommets, lugs, termination kits etc. on as required basis.
- ii) Bidder shall furnish two completely new sets of cable termination kits like crimping tools, maxi-termi/wire-wrap tools etc. which are required for maintenance of the system.

6.10.7 Field Mounted Local Junction Boxes

- i) No. of ways 12/24/36/48/64/72/96/128 with 20% spare terminals.
- ii) Material and Thickness 4mm thick fibre glass reinforced polyester.
- iii) Type Screwed at all four corners for door. Door handle shall be of SS. Self locking with common key. Door gasket shall be of synthetic rubber.
- iv) Mounting clamps and accessories Suitable for mounting on walls, columns, structures etc. The brackets, bolts, nuts, screws, glands and lugs required for erection shall be of brass, included in Bidders scope of supply.
- v) Type of terminal Rail mounted maxi termi or cage-clamp type



- blocks suitable for conductor size upto 2.5 mm². A M6 earthing stud shall be provided.
- (vi) Protection Class IP:55 minimum

6.10.8 Conduits

All rigid conduits, couplings and elbows shall be hot dipped galvanised rigid mild steel in accordance with IS:9357 Part-I (1980) and Part-II (1981). The conduit interior and exterior surfaces shall have a continuous zinc coating with an overcoat of transparent enamel lacaner or zinc chromate. Flexible conduit shall be heat resistant lead coated steel, water leak, fire and rust proof. The temperature rating of flexible conduit shall be suitable for actual application.



6.11 MAINTENANCE AND CALIBRATION EQUIPMENT

- i) Maintenance and calibration equipment of proven type, as specified under this sub-section, shall be provided as a minimum by the Bidder. However any other equipment deemed necessary by the Bidder for maintenance and calibration of C&I devices/systems shall be included in Bidder's quoted price. The Bidder shall be responsible for supplying any necessary additions of tools as required for proper maintenance and calibration of the installed C&I devices/systems.
- ii) Electrical power supply requirement of the instruments offered under this sub-section shall be 240 V AC, 50 Hertz nominal, single phase, unless specified otherwise.
- iii) Microprocessor based instruments shall be offered wherever specified. The make, model, range and other technical features of the maintenance and calibration equipments shall be as finalised during detailed engineering. The Bidder shall be responsible for erection and commissioning of maintenance and calibration equipments and for setting up of the electronic & pneumatic C&I laboratory including provision of necessary furniture necessary for mounting of all equipment & working space, tables, chairs, trolleys etc. as finalised during detailed engineering. The laboratory shall be modular in design, enabling easy change of arrangement wherever applicable.
- iv) All the microprocessor based maintenance and calibration units should also have the provision for data logging facility for keeping calibration/maintenance records with proper communication facility for download these data on the laboratory PC.
- v) All required accessories for the maintenance and calibration equipments shall be included whether specifically indicated herein or not.
- vi) The following maintenance and calibration equipments as specified in this section shall be furnished common for both the units.

6.11.1 Test Bench

- i) Electronic Test Bench

One number electronic self contained test bench made of anodized aluminum for testing and repair of electronic instruments and gadgets shall be furnished. It shall be modular in design, enabling easy change of arrangement. The test bench shall be complete with power packs (AC and DC) receptacles, (AC/DC) meters digital multi meter etc. The various voltage levels, shall be finalized during detailed engineering. However, the minimum are indicated below:

- a) 0-260V, 1phase, 50 Hz, 10Amp for one socket.



- b) 240 V, 1phase, 50 Hz, 3 KVA stabilized having six sockets.
- c) ± 48 V D.C, 3A for 2 sockets.
- d) ± 24 V D.C, 6A for 2 sockets.
- e) ± 12 V D.C, 10A for 2 sockets.
- f) 0-60 VDC $\pm 0.02\%$, 1A for one socket.

ii) **Pneumatic Test Bench**

One number pneumatic test bench made of anodized aluminium, modular in design, enabling easy change of arrangement/layout as and when required, shall be provided for testing/calibration of pneumatic instruments/devices. The test bench shall be complete with valves, pressure gauges, filter regulators, overload protection feature etc.

6.11.2 Mechanical Items

i) **Dead Weight Tester:** one number

Dual range dead weight pressure gauge tester with all required accessories shall be provided for testing of pressure gauges. The measuring range shall be 1 - 600 kg/cm² with an accuracy not less than 0.03% other requirement shall be as per detailed engineering.

ii) **Vacuum Tester:** one number

Air operated dead weight type vacuum tester along with electrically operated vacuum pump and all required accessories shall be furnished. It shall have a measuring range of 15-1000 mm bar and an accuracy of $\pm 0.03\%$ or better.

iii) **Hydraulic Pressure Gauge Tester:** one number

A hydraulic pressure gauge tester comprising of primary pump using light hydraulic mineral oil shall be furnished to compare the gauge under test with a standard test gauge for pressures up to 1200 kg/cm². The accuracy shall be $\pm 0.05\%$ of full scale. Gauge connection shall be 1/2", 1/4" & 1/8" NPT. All required accessories are to be supplied.

iv) **Portable Hydraulic Pressure Generator:** one number

Portable hydraulic pressure generator comprising of two stage pump using light hydraulic oil shall be provided to generate pressure of approx. 15 bar (1st stage) and 700 bar (second stage). Provision for mounting standard pressure gauge and five volume adjustment shall be there with the unit.



v) **Portable Pressure Calibrator:** two numbers

It shall be microprocessor based and operated by rechargeable battery and by 240 AC, single phase, 50 Hz. Accuracy shall be $\pm 0.05\%$. Overpressure protection & indication shall be provided. Tentative pressure range shall be (-)1.06 bar to 1000 bar (subject to finalisation during detailed engineering). All required accessories to be provided.

vi) **Manometers**

a. Test Manometers (Mercury well type): two numbers

It shall have 1500 mm extended transparent plastic tube. Scale shall be compensated for liquid level changes and shall be graduated in mm of Hg and kg/cm² Body shall be made of steel. Test pr. to be 17.5 kg/cm². All accessories to be provided.

b. U-Tube Manometers (Mercury filled) : two numbers

Manometer shall be clear plastic U tube/ Borosilicate glass tube. The scale range shall be (-) 1000-0-1000 mm having 1mm smallest division and zero adjustment facility. All wetted parts shall be 304SS. All required accessories to be provided.

vii) **Secondary Standard Quality Pressure Gauges:**

The bidder shall provide 2 sets of secondary standard quality pressure gauges of each range as required for comparing different gauges in the Bidder's scope. Accuracy shall be $\pm 0.25\%$ of full scale or better.

viii) **Air Sets :** 4 numbers

Input - 6 - 7 kg/cm² as per Instrument Air system.

Output - As required by Instrument/drive

Filter - 5 micron.

ix) **Portable Electro-Pneumatic Calibrators:** two numbers

The electro-pneumatic calibrator shall be microprocessor based and used for calibration of electronic and pneumatic instrumentation as supplied by the Bidder. These shall have accuracy of $\pm 0.05\%$ & shall be complete with all adapters & accessories. 4 - 20 mA DC output to be provided for E/P converter and E/P converter output should also be measured by it. Power supply shall be (i) rechargeable battery and (ii) 240 V, 1 phase, 50 Hz.



- x) **Fluidized Temperature Bath** : one number
- The temperature bath shall be microprocessor based and shall have fully controlled temperature range of 100 to 600 deg. C. Temperature stability shall be ± 0.2 deg.C or better over whole range.
- xi) **Thermocouple Test Furnace** : one number
- This furnace shall be microprocessor based and used for precise comparison of upto 6 test thermocouples with a checking thermocouple upto a maximum temperature of 1200 deg.C. It shall be suitable to make temperature checks with least uncertainty of about ± 1 deg. C over the full range.
- xii) **Barometers** : two numbers
- The Bidder shall furnish precision aneroid barometers, accurate to $\pm 0.3\%$ of full scale or better. Dial size shall be 150 mm. Graduation shall be 0.5 mm and range shall be as per detailed engineering.
- xiii) **Mercury Thermometers** : two sets of approximately 12 nos. each
- These shall cover a temperature range of -10 deg.C to 600 deg.C. Various split ranges shall be as per detailed engineering.
- xiv) **Flowmeter Calibrators** : three numbers
- One each for the ranges 0-1000mm WCL, 0-6000mm WCL & 0-30,000mm WCL. Type shall be finalized during detailed engineering. and will be subject to Purchaser approval.
- xv) **Portable Tachometer**: one number
- It should be latest proven non contact type suitable upto 6000 RPM.
- xvi) **Coil Winding Machine** : one number
- It shall be single phase motor driven with all accessories to wind wires of dia 0.001" to 0.036".
- xvii) **Stop Watches** : three numbers
- It shall have provision of Analog & Digital display.
- xviii) Precision instrument radial drilling machine with all standard tools.(1 no.)
- xix) Jewelers lathe, with provision for screw cutting, precision cutting and other related mechanical work, with all necessary accessories & CAD/CAM software. (1 no.)



- xx) Standard tool box for instrument maintenance work. (2 sets)
- It shall comprise of multi purpose screw drivers, Ratchet screw drivers, star screw drivers, spanners, cutters, pliers, allen keys (all type), Nose plier, Rough & smooth files, slide & pipe wrench etc.
- xxi) **Wet & dry bulb hygrometer:** Two numbers
Measuring range shall be 20% - 100% with digital indication. Accuracy shall be $\pm 0.2\%$.
- xxii) **Soldering/ desoldering station:** Two numbers
- Precision type with built in temperature controller. All required accessories shall be provided.
- xxiii) **Vacuum pump :** One number complete with vacuum gauge (0-760 mmHg) shall be able to provide vacuum of 3×10^{-2} mbar or better. It should be provided with all accessories.
- xxiv) **Solder sucker** - Three numbers.
- xxv) **Motor & Hand operated wire wrap tools** - 1 number of each type with all accessories and suitable for various pin size used.
- xxvi) **Maxitermi Guns** :- 3 nos. electrically operated + 3 nos. hand operated. It should be suitable for various sizes of maxitermi type connection specification such as length, width and shall be as finalised during detailed engineering.

6.11.3 Electrical Items

- i) **Digital Multimeters**
- Quantity : 3½ digit handheld - 10 nos, 4½ digit handheld - 4 nos. and 4½, 5½, 6½ Desk top model - 2 nos. each.
- Type, signal & ranges shall be as per detail engineering. subject to Purchaser approval. Input resistance shall be 10 M ohm , ambient temp. shall be 0-50°C.
- ii) **Portable Current Calibrator** : five numbers
- This instrument shall be microprocessor based and provide an accurate and reliable measurement of milliamp signals and shall generate milliamp signals for use in calibrating receiver type instrumentation. Accuracy shall be $\pm 0.05\%$ of selected span or better. CMRR (DC to 50 Hz) of 0.1 micro Amp/ volt and ambient temp. errors of 0.0005% per °C. The instrument should be powered by (i) 240 V, 1 phase, 50 Hz & (ii) by self contained rechargeable battery. The selectable input & output range shall be 0-10/ 0 - 100 mA DC with built in auto overload protection.



- iii) **Portable Millivolt Calibrator** : five numbers
- This instrument shall be microprocessor based and provide an accurate and reliable measurement of millivolt/ thermocouple signals and shall generate millivolt signals for calibration of receiver type instrumentation. Accuracy shall be $\pm 0.02\%$ of selected span or better. The instrument should be powered by (i) 240 V, 1 phase, 50 Hz and (ii) by self contained rechargeable battery. The selectable input & output range shall be 0-10 mv/ 0-100 mv/ 0-1000 mvDC. CMRR (DC to 50 Hz) shall be 120 db and ambient temp. error shall be $\pm 0.005\%$ per 1°C .
- iv) **Resistance Thermometer Bridge** : two numbers
- This instrument shall provide measurement of resistance values for verification of RTD elements and receiver instrumentation. The resolution and accuracy shall be 0.001 ohms and $\pm 0.005\text{ohm}$ or better respectively. The range shall be 0-1000ohms.
- v) **Decade Resistance Box** : two numbers
- This variable resistance device shall provide an accurate resistance source for calibration of RTD elements and receiver devices. Accuracy shall be $\pm 0.05\%$ or better. Resistance range shall be 0-100 K ohm and increments shall be 0.1 ohm.
- vi) **Variac**: One number
- Light weight variac, providing variable voltage upto 500 V shall be provided. Input shall be 415V, 3 phase, 50 Hz.
- vii) **Rheostat/Potentiometer** : Ten numbers
- Two nos. each of following ratings :
- 18 Amps, 1 Ohm; 15 Amps, 1.4 Ohms; 12 Amps, 3 Ohms; 8.5 Amps, 6.5 Ohms; 5 Amps, 18 Ohms. They shall be wire wound continuously variable type. The insulation resistance shall be more than 5 M ohms at 500 VDC between terminal & case.
- viii) **Test Resistance Temperature Detectors** Two numbers
- The resolution be 0.001°C and range shall be 0 to 1000°C .
- ix) **Portable Thermocouple/RTD calibrator/simulator** : One number
- This microprocessor based instrument shall be used for calibration/ simulation of thermocouples /RTDs as supplied by the Bidder. The linearisation accuracy shall be ± 0.01 of reading or better and calibration accuracy shall be $\pm 0.05\%$ or better. Range shall be as per detailed engineering. it should be suitable for 240V, 1phase, 50 Hz power supply and (ii) rechargeable type batteries. All accessories to be provided.



x) **Portable Multi-Function Counter** : One number

The Bidder shall furnish microprocessor based and crystal-controlled oscillator based, dual channel multi-function counter to measure frequency, period, frequency ratio, time interval and unit count. The accuracy for frequency shall be ± 1 count \pm time base error.

xi) **Digital Storage Oscilloscope** : One number

Latest proven two channel, digital storage oscilloscope will be supplied for the instrument shop. All required accessories including probes shall be provided.

xii) **Power Pack** : Two numbers

Two numbers of highly stabilized, solid state, power supply packs with over voltage/current limiting output protections shall be provided for output range of 0-60 VDC regulation shall be 0.01% or better.

xiii) **Portable Vibration Meter**: One number

This instrument shall be of latest & proven design capable of measuring vibration of machinery in terms of displacement, velocity and acceleration. Power supply shall be (i) 240V, 1 ohm, 50 Hz and (ii) rechargeable batteries. All required accessories shall be provided. The displacement, velocity & acceleration ranges shall be 0-3000 microns, 0-300 mm/sec and 0-100 mm/sec² respectively.

xiv) **Portable Vibration Analyzer/Dynamic Balancer** : One number

This instrument shall be of latest & proven design and will be powered by a self contained rechargeable battery pack and shall be designed to operate also from a 240V AC, 50 Hz , 1 phase power supply with the battery pack removed.

This shall have frequency range of 50 to 500000 cpm and vibration range in terms of displacement/velocity/acceleration shall be 0-3000 microns/0-3000 mm/sec/0-1000gs respectively. All required accessories shall be provided. Outputs shall be in terms of built in XY plotter, diagnostic & message printout, analog amplitude & frequency meter.

xv) **RCL Bridge** : One number

Microprocessor based RCL bridge shall be provided. The measurement accuracy shall be $\pm 0.5\%$ of reading or better. R,C,L range shall be as per detailed engineering.



- xvi) **pH Simulator** : One number
- Range: 0 -14 pH in steps of 1 pH, Accuracy: +/-0.01 pH. Power supply shall be (i) 240 VAC, 1 phase, 50 Hz and (ii) rechargeable battery. All accessories to be provided.
- xvii) **Multi-channel Simulation Unit (Analog)** : Three number
- Number of channels: 20, Accuracy : +/- 0.1% of span. Output voltage shall be as per detailed engineering. The channel shall have in individual potentiometer to set the output at desired magnitude and shall also have vernier settings to set the output in millivolt.
- xviii) **Digital Channel Simulator** : Three number
- Number of channels : 40, Status selection by toggle switches. It shall produce digital output of 0 to 5 V provision for free output contacts for on/off status to be also provided.
- xix) **Logic Probe, Quantity** : four numbers
- It should test all digital circuits based on CMOS, TTL, DTL etc. other specification shall be as per detailed engineering.
- xx) **Function Generator**: one number
- a) Waveforms - Sine, square, triangle, pulse and ramp with variable symmetry.
 - b). Symmetry- 10% to 90%, 1% step, +/- 2% accuracy
 - c) Frequency- Range : 0.002 Hz to 20 MHz Accuracy : (a) Continuous mode - +/-0.1%; (b) Trigger, gate, burst modes - +/- 0.1% (for freq. less than or equal to 200 Hz) & +/- 5.0% (For freq. more than 200 Hz)
 - d) Resolution : Continuous mode - 4 digits.
 - e) Amplitude range : 20 mv to 20 Vp-p (open ckt).
: 10 mv to 10 Vp-p (50 ohm load).
- xxi) **Logic Analyzer**
- Two numbers microprocessor based latest proven type of portable logic analyzers, which are highly flexible, (so that they can be connected to many different circuit points easily and also to provide a clear visual display for the user), shall be furnished. Specification shall be as per detail engineering. All required accessories to be provided.



- xxii) **Portable infrared thermometer** : One number
- Range shall be from 900 to 1600 deg C with resolution of 1deg C. Accuracy shall be $\pm 1\%$ of full scale. Power supply shall be (1) 240V, 1 phase, 50 Hz & (2) chargeable battery. all required accessories to be provided.
- xxiii) **Clip on AC power meter** : One number
- Range shall be 20-600 vrms, 0.2-20A rms, 0.2-20 KW and accuracy shall be $\pm 1\%$ of rdg $+0.5\%$ of range. Display shall be 3 1/2 digit LCD. All accessories to be provided.
- xxiv) **Portable gas analyzer**: one number
- It shall be latest proven type. various measurements such as O₂, CO, NO_X, SO₂, opacity etc. shall be as per detailed engineering. only.
- xxv) DDCMIS Modules Testing kit for complete diagnostic testing of DDCMIS modules in addition to built in diagnostics present in DDCMIS. The facilities shall include functional processor test, working memory test, communication controller test, I/O modules test as a minimum.
- xxvi) **Digital insulation tester** : two numbers
- It should measure upto 100 M ohm at 500 V.
- xxvii) **EPROM Programmer** : one number
- Latest proven universal type PC based EPROM programmer with necessary software & hardware. It shall be possible to burn & reprogram all types of chips used in various microprocessor based system : All required accessories to be provided.
- xxviii) **Laboratory PC** : one no.
- The laboratory PC shall be with latest configuration.. In addition, suitable connectors and associated software(s) for downloading of logged data from various maintenance & calibration instruments shall also be provided.

6.11.4 Other Items for the Laboratory

- | | | | |
|----|--|---|-------|
| a) | Engraving Machine | : | 1 no. |
| b) | Photocopying Machine,
light duty light duty with
facility for A3/A4 size
enlarging/ reduction,
autofeed & multicopying | : | 1 no. |
| c) | Drawing Laminator | : | 1 no. |



6.12 PLC BASED MISCELLANEOUS CONTROL SYSTEMS

6.12.1 General Requirements

- i) Contractor shall provide complete and independent PLC based Control and Instrumentation system with all accessories, auxiliaries and associated equipments and cables for the safe, efficient and reliable operation of the following plant auxiliary systems mentioned below.

- a) Turbine Lube Oil Purification System
- b) Central Lube Oil Purification System
- c) Condensate Polishing System
- d) Any other such standalone system

- ii) Bidder shall include in his proposal all instruments and devices, which are needed for the completeness of the system. Same shall be subject to approval of the purchaser during detailed engineering.

All instruments and control equipments like primary and secondary instruments etc. shall meet the requirements specified in sub-section on Measuring Instruments. In addition, all electrical instrument devices like switches/transmitters/ controllers/ analysers/ solenoid valves which are located in the field/hazardous locations shall be provided with explosion proof enclosure suitable for hazardous areas described in National Electric Code (USA), Article 500, Class-I, Division-I. All field wiring should be through conduits. All fittings, cable glands etc. shall be strictly as per NEC recommendation article, 500 to 503.

ON/OFF control, indication, annunciation of incomers and bus-coupler are also to be performed from contractor's control system for each of the above system as applicable.

The control system shall be able to operate in non-air conditioned area and shall meet the minimum requirements as specified below.

6.12.2 Programmable Logic Based Control System

- i) PLC Processor

The processor unit shall be capable of executing the following functions:-

- a) Receiving binary and analog signals from the field and operator initiated commands from OWS/ control panel.
- b) Implementing all logic functions for control, protection and annunciation of the equipment and systems.
- c) Implementing modulating control function for certain application as specified elsewhere in the specification.



- d) Issuing control commands.
 - e) Providing supervisory information for alarm, various types of displays, status information, trending, historical storage of data etc.
 - f) Performing self-monitoring and diagnostic functions.
-
- ii) The controller shall provide all basic functions for binary gating operations, modulating controls, storage, counting, timing, logging, transfer operations and comparison functions. The Contractor in his bid shall submit full details regarding various functions alongwith expansion capability.
 - iii) The programmable system shall be delivered completely programmed for the complete and reliable operation of the plant.
 - iv) Each PLC unit shall be provided with two processors (Main processing unit and memories) one for normal operation and one as hot standby. In case of failure of working processor, there shall be an appropriate alarm and simultaneously the hot standby processor shall take over the complete plant operation automatically. The transfer from main processor to standby processor shall be totally bumpless and shall not cause any plant disturbance whatsoever. In the event of both processors failing, the system shall revert to fail safe mode. It shall be possible to keep any of the processors as master and other as standby. The standby processor shall be updated in line with the changes made in working processor.
 - v) The memory shall be field expandable. The memory capacity shall be sufficient for the complete system operation and have a capability for at least 20% expansion in future. Programmed operating sequences and criteria shall be stored in non volatile semi conductor memories like EPROM. All dynamic memories shall be provided with buffer battery back up which shall be for at least 360 hours. The batteries shall be lithium or Ni-Cd type.
 - vi) The PLC system shall be provided with necessary interface hardware and software for dual fibre optic connectivity & interconnection with station wide LAN for two - way transfer of signals for the purpose of information sharing. The plant information shall be made available through an OPC compliant Ethernet link following TCP/IP standard. The exact data structure shall be as decided during detailed engineering. All required plant data shall be transferred to/from through this ensuring complete security. The exact number of points to be transferred through the above communication link and the format of the data shall be finalised during detailed engineering.
 - vii) Two (2) nos latest version of PC based Operator Work Stations (OWS) each with 19" color TFT's and key boards shall be provided for control & monitoring and programming function. One no. number heavy duty A3 size color inkjet printer shall be provided along with operator work station.

PC based OWS shall perform control, monitoring and operation of all auxiliaries/ drives interacting with PLC based control system. It shall be possible to use the same as programming station of the PLC. It shall basically perform the following functions.



In case the PC based OWS can not be used as programming station of the PLC, then a separate PC based programming station shall be provided.

- a) Operator interface for PLC based control system. Operator functions shall as minimum include local/ remote selection, A/M selection, open/ close operation, sequence auto, start/ stop selection, ON/OFF, bypassing criteria etc.
- b) Supervisory functions like:-
Mimic displays, which shall depict the process in graphical form and shall cover all the process areas being monitored.

Alarm monitoring/reporting, generation of logs, calculations, printing of logs & reports etc.

- c) Suitable Interface with stations wide LAN (In Purchaser's Scope) for two-way transfer of data.
- viii) Programming station shall have access to the processor of the control system for programming. Programming shall not require special computer skills. On the programming console, it shall be possible to do the programming, self-diagnostics, testing of sequence, simulation and any sequence modification.

Programming shall be possible in any of the following formats :

- a) Flow-chart or block logic representing the instructions graphically.
- b) Ladder diagrams.

A forcing facility shall be provided for changing the states of inputs and outputs, timers and flags to facilitate fault finding and other testing requirements. It shall be possible to display the signal flow during operation of the program. Programming shall be possible OFF line.

A NORMAL / TEST / PROGRAM / OFF lockable selector switch shall be provided. In case of test mode of operation, all outputs should be blocked.

- ix) Provision shall be made for erasing and duplicating the user program and long term storage facilities shall be provided with the help of mag. Tape cartridge or EPROM.
- x) Manual intervention shall be possible at any stage of operation. Protection commands shall have priority over manual commands and manual commands shall prevail over auto commands.
- xi) In PLC controller, memory should exist as to where the sequence was aborted due to power supply failure so that further operation from that point can restart after power supply restoration. This restart after recovery of the power supply shall be through operator intervention so as to enable verification of readiness of other related equipments.



- xii) All necessary software required for implementation of control logic, operator station displays / logs, storage & retrieval and other functional requirement shall be provided. The programs shall include high level languages as far as possible. The contractor shall provide sufficient documentation and program listing so that it is possible for the Purchaser to carry out modification at a later date.
- xiii) The Contractor shall provide all software required by the system for meeting the intent and functional/parametric requirements of the specification.
 - a) Industry standard operating system like UNIX/WINDOWS NT etc. to ensure openness and connectivity with other system in industry standard protocols (TCP-IP/ OPC etc.) shall be provided. The system shall have user oriented programming language & graphic user interface.
 - b) All system related software including Real Time Operating System, File management software, screen editor, database management software. On line diagnostics/debug software, peripheral drivers software and latest versions of standard PC-based software and latest WINDOWS based packages etc. and any other standard language offered shall be furnished as a minimum.
 - c) All application software for PLC system functioning like input scanning, acquisition, conditioning processing, control and communication and software for operator interface of monitors, displays, trends, curves, bar charts etc. Historical storage and retrieval utility, and alarm functions shall be provided.
 - d) The Contractor shall provide software locks and passwords to Purchaser's engineers at site for all operating & application software so that Purchaser's engineers can take backup of these software and are able to do modifications at site.

6.12.3 Input/Output Modules

- i) The PLC system should be designed according to the location of the input/output cabinets as specified.
- ii) Input Output modules, as required in the Control System for all type of field input signals (4-20 mA, RTD, Thermocouple, non change over/change over type of contact inputs etc.) and outputs from the control system (non change over/change over type of contact, 24/48 VDC output signals for energising interface relays,4-20 mA output etc.) are to be provided by the Contractor.
- iii) Electrical isolation of 1.5KV with optical couplers between the plant input/output and controller shall be provided on the I/O cards. The isolation shall ensure that any inadvertent voltage or voltage spikes (as may be encountered in a plant of this nature) shall not damage or mal-operate the internal processing equipment.
- iv) The Input/output system shall facilitate modular expansion in fixed stages. The individual input/output cards shall incorporate indications on the module front panels for displaying individual signal status.



- v) Individually fused output circuits with the blower fuse indicator shall be provided. All input/output points shall be provided with status indicator. Input circuits shall be provided with fuses preferably for each input, alternatively suitable combination of inputs shall be done and provided with fuses such that for any fault, fuse failure shall affect the particular drive system only without affecting other systems.
- vi) All input/output cards shall have quick disconnect terminations allowing for card replacement without disconnection of external wiring and without switching of power supply.
- vii) The Contractor shall provide the following monitoring features:
 - a) Power supply monitoring.
 - b) Contact bounce filtering.
 - c) Optical isolation between input and output signals with the internal circuits.
 - d) In case of power supply failure or hardware fault, the critical outputs shall be automatically switched to the fail-safe mode. The fail-safe mode shall be intimated to the successful Contractor during detailed engineering.
- viii) Further, keying-in of individual wire connectors shall be provided to ensure that only the correct card is plugged on the I/O module. It shall be possible to remove I/O module without disconnecting wiring from field inputs or outputs. There shall be atleast 20% spare capacity available on input, output and memory modules, over and above the system requirement.
- ix) Binary Output modules shall be rated to switch ON/OFF coupling relays of approx. 3 VA at 24 VDC. Analog output modules shall be able to drive an load impedance of 500 Ohms minimum.
- x) Output module shall be capable of switching ON/OFF inductive loads like solenoid valves, auxiliary relays etc. without any extra hardware.
- xi) Only one changeover contact shall be provided in MCC for control and interlock requirement. Further multiplication, if required, shall be done by the contractor in PLC system.
- xii) All input field interrogation voltage shall be 24V DC or 48 V DC.
- xiii) In case of loss of I/O communication link with the main processing unit, the I/O shall be able to go to predetermined fail safe mode (to be decided during detailed engineering) with proper annunciation.
- xiv) Contractor shall provide for 20% spare I/O modules in each system cabinet to take care of any further addition.



6.12.4 Printer

One number A3 size color inkjet printer per PLC shall be provided as a part of the supervisory system. It shall print out all alarm/trip conditions and event changes in plant status alongwith date and time of occurrence. The time least count for event recording shall not be more than 100 milliseconds.

6.12.5 Data Communication System (DCS)

The DCS shall include a redundant System Bus with hot back-up and other applicable bus systems like cubicle bus, local bus, I/O bus etc.

The DCS shall have the following minimum features :

- a) Redundant communication controllers shall be provided to handle the communication between I/O Modules (including remote I/O) and PLCs and between PLCs and operator work station.
- b) The design shall be such as to minimise interruption of signals. It shall ensure that a single failure anywhere in the media shall cause no more than a single message to be disrupted and that message shall automatically be retransmitted. Any failure or physical removal of any station/module connected to the system bus shall not result in loss of any communication function to and from any other station/module.
- c) If the system bus requires a master bus controller philosophy, it shall employ redundant master bus controller with automatic switchover facility.
- d) Built-in diagnostics shall be provided for easy fault detection. Communication error detection and correction facility shall be provided at all levels of communication. Failure of one bus and changeover to the standby system bus shall be automatic and completely bumpless and the same shall be suitably alarmed/ logged.
- e) The design and installation of the system bus shall take care of the environmental conditions as applicable.
- f) Data transmitting speed shall be sufficient to meet the responses of the system in terms of displays, control etc. plus 25% spare capacity shall be available for future expansion.
- g) Passive coaxial cables or fibre optic cables shall be employed.

The Contractor shall furnish details regarding the communication system like communication protocol, bus utilisation calculations etc.



6.12.6 System Reaction Time

The reaction time of the programmable control system from input signals at the input cards to output of the associated signals or commands of the output card inclusive of programmed logic processing, comprising a mixture of logic gates, arithmetic operations and other internal operations shall be less than 250 milli seconds under the most arduous control system operating conditions. However, for specific applications, it shall be less than 100 milli seconds.

6.12.7 Operator Interface Displays/Logs

Suitable displays and reports for control operation & monitoring shall be provided. The details shall be finalised during detailed engineering stage.

6.12.8 Control & Power Supply Scheme

- i) For PLC system, redundant 24 V DC power supply shall be provided by the contractor. Necessary redundant transformers and redundant chargers with 24 V DC battery back-up shall be provided by the Contractor to derive power supply from 415 V, 3-phase redundant incomers to be provided by Purchaser at the input terminals of Power supply cabinets. The Contractor shall, however, furnish all required hardware/ equipment/ cubicles for conversion and/or stabilisation of the power source provided by the Purchaser to all other levels which may be necessary for meeting the individual requirements of equipments/ systems furnished by him within the Contractor's quoted lumpsum price.

For separately mounted I/O racks, separate power supplies shall be provided. Power supply module shall be of ample capacity to supply all modules. In addition 20% spare capacity for future shall be provided. All the drives shall be switched ON/OFF through 24V DC coupling relays to be provided in HT/LT SWGR panels. Power supply distribution from Contractor's power supply cabinets shall be in the scope of Contractor. The exact power supply scheme shall be as approved by Purchaser during detailed Engineering stage.

- ii) Each set of PC along with TFT shall be provided with smart type line interactive UPS with software & hardware for remote management along with features of surge suppression & AVR facility by the Contractor. The UPS shall be of sufficient capacity of at least 30 minute at machine load.
- iii) The battery shall be sealed maintenance free Ni-Cd type or Plante type Lead Acid batteries with long life and shall be able to provide a back-up for one hour at full load requirement of the complete control system.

6.12.9 Control Cabinets / Panels / Desks

- i) The cabinets shall be IP-22 protection class. The Contractor shall ensure that the packaging density of equipment in these cabinets is not excessive and abnormal temperature rise, above the cabinet temperature during normal operation or air-conditioning failure, is prevented by careful design. This shall be demonstrated to the Purchaser during the factory testing of the system. The Contractor shall ensure that the temperature rise is limited to 10 deg. C above ambient and is well within the safe limits for system



components even under the worst condition as specified in Sub-section-basic Design criteria and specification requirements for remote I/O cabinets.

Ventilation blowers shall be furnished as required by the equipment design and shall be sound proof to the maximum feasible extent. If blowers are required for satisfactory system operation, dual blowers with blower failure alarm shall be provided in each cabinet with proper enclosure and details shall be furnished with proposal. Suitable louvers with wire mesh shall be provided on the cabinet.

- ii) The cabinets shall be designed for front access to system modules and rear access to wiring and shall be designed for bottom entry of the cables.
- iii) The cabinets shall be totally enclosed, free standing type and shall be constructed with minimum 2 mm thick steel plate frame and 1.6 mm thick CRCA steel sheet or as per supplier's standard practice for similar applications, preferred height of the cabinet is 2200 mm. The cabinets shall be equipped with full height front and rear doors. The floor mounting arrangement for other cabinets shall be as required by the Purchaser and shall be furnished by the Contractor during detailed engineering.
- iv) Cabinet doors shall be hinged and shall have turned back edges and additional bracing where required ensuring rigidity. Hinges shall be of concealed type. Door latches shall be of three-point type to assure tight closing. Detachable lifting eyes or angles shall be furnished at the top of each separately shipped section and all necessary provisions shall be made to facilitate handling without damage. Front and rear doors shall be provided with locking arrangements with a master key for all cabinets. If width of a cabinet is more than 800 mm, double doors shall be provided.
- v) Two spray coats of inhibitive epoxy primer-surface shall be applied to all exterior and interior surfaces. A minimum of 2 spray coats of final finish colour shall be applied to all surfaces. The final finished thickness of paint film on steel shall not be less than 65-75 micron for sheet thickness of 2 mm and 50 microns for sheet thickness of 1.6 mm. The finish colors for exterior and interior surfaces shall conform to following shades:

Exterior:- As per RAL 7032 or as finalised and specified during detailed engineering.

Interior:- Same as above.

Paint films which show sags, checks or other imperfections shall not be acceptable.

- vi) Cabinets shall be designed for a grounded installation on the building structure. Any isolation from the building ground which is required by equipment design shall be provided internal to the cabinet.



- vii) The mimic shall be configured on the OWS/ TFTs and it shall be possible to control, monitor and operate the plant from the same.
- viii) Ammeters will be provided on control panel for all motors rated 30KW and above. Further, HT/LT switchgear voltmeters shall be provided on control desk for HT/LT feeders. Ammeters and voltmeters shall be suitable for 4-20 mA DC signals derived from Analog Output cards of PLC.
- ix) Mosaic based control desk type for mounting push buttons/meters etc. with door at the rear shall be provided by the contractor. The mosaic grid tiles shall be of 24mmx48mm (or 25mmx50mm) size, made of heat and flame retardant, self extinguishing and non hygroscopic material with flat-matt finish without glare and non reflecting type. PC based OWS(operator Work Station) of PLC shall be mounted on table type control desk to house PC/ keyboards/ mouse etc. The profile and dimension shall be decided during detailed engineering and shall be subject to Owner's approval.
- x) The technical specification covering panel fabrication details, wiring and termination details etc. shall be as described under Instrumentation Cables of this volume.

6.12.10 Annunciation System

- i) Contractor shall provide annunciation system as integral part of PLC system. Field contacts shall be acquired through PLC only. The annunciation sequence logics shall be implemented as a part of PLC controllers. The annunciation window lamps mounted on control panel shall be driven through contact output modules of PLC. It shall be preferable to have each window as mosaic compatible. The lamp box shall have removable impact polystyrene window shall be 50 mm x 50 mm or 48mm x 48mm with 5 mm size inscription in black lettering on white background. Each annunciation window shall be backlighted with two long life LED lamps The changing of lamps shall be conveniently done from the front by single removal of window. Redundant audible devices for alarms shall be cone type or metallic horn type and shall be driven by electronic tone generator of adjustable width and sound level. The trip alarm audible & ring back audible shall be differentiated from other alarms.
- ii) The annunciator sequence shall conform to ISA sequence ISA-2A. The number of annunciation facia windows and the provision for original input will be on as required basis. However, the minimum number of facia windows, signal input to the annunciation system shall be 25 nos.

6.12.11 Software Documentation and Software Listings

- i) All technical manuals, reference manuals, user's guide etc., in English required for modification/editing/addition/deletion of features in the software of the PLC System shall be furnished. The Contractor shall furnish a comprehensive list of all system/application software documentation after system finalisation for Purchaser's review and approval.



ii) All The software listings including Source code for application software, All special-to-project data files etc. shall be submitted by the Contractor:

iii) Software Licences

The Contractor shall provide software license for all software being used in DDCMIS. The software licenses shall be provided for the project (e.g. organisation or site license) and shall not be hardware/machine-specific. That is, if any hardware/machine is upgraded or changed, the same license shall hold good and it shall not be necessary for Purchaser to seek a new license/renew license due to upgradation/change of hardware/machine in DDCMIS at site. All licenses shall be valid for the continuous service life of the plant.

iv) Software Upgrades

As a customer support, the Contractor shall periodically inform the designated officer of the Purchaser about the software upgrades/new releases that would be taking place after the system is commissioned so that if required, same can be procured & implemented at site.



6.13 TYPE TEST REQUIREMENTS

6.13.1 General Requirements

- i) The contractor shall furnish the type test reports of all type tests as per relevant standards and codes as well as other specific tests indicated in this specification. A list of such tests are given for various equipment in table titled 'Type Test Requirement for C&I Systems' at the end of this sub-section. For the balance equipment instrument, type tests may be conducted as per manufactures standard or if required by relevant standard.
- ii)
 - (a) Out of the tests listed, the bidder/ sub-vendor/ manufacturer is required to conduct certain type tests specifically for this contract (and witnessed by Purchaser or his authorized representative) even if the same had been conducted earlier, as clearly indicated subsequently against such tests.
 - (b) For the rest, submission of type test results and certificate shall be acceptable provided.
 - i. The same has been carried out by the bidder/ sub-vendor on exactly the same model /rating of equipment.
 - ii There has been no change in the components from the offered equipment & tested equipment.
 - iii. The test has been carried out as per the latest standards alongwith amendments as on the date of bid opening.
 - (c) In case the approved equipment is different from the one on which the type test had been conducted earlier or any of the above grounds, then the tests have to be repeated and the cost of such tests shall be borne by the bidder within the quoted price and no extra cost will be payable by the purchaser on this account.
 - iii) As mentioned against certain items, the test certificates for some of the items shall be reviewed and approved by the bidder or his authorized representative and the balance have to be approved by the purchaser.
 - iv) The schedule of conduction of type tests/ submission of reports shall be submitted and finalized during pre-award discussion.
 - v) For the type tests to be conducted, contractor shall submit detailed test procedure for approval by purchaser. This shall clearly specify test setup, instruments to be used, procedure, acceptance norms (wherever applicable), recording of different parameters, interval of recording precautions to be taken etc. for the tests to be carried out.
 - vi) The bidder, shall indicate in his bid, the cost of the type test for each items only for which type tests are to be conducted specifically for this project.



6.13.2 Special Requirement for Solid State Equipments/ Systems

The minimum type tests reports, over and above the requirements of above clause which are to be submitted for each of the major C&I systems like SG-C&I system, TG- C&I system, BOP- C&I system, Flame monitoring system, Coal feeders control and instrumentation system, Boiler flame analysis system, Electronic remote drum level monitoring system, Turbine supervisory system, BFP Turbine supervisory instruments, Analyzer instruments, Vibration monitoring systems, etc. shall be as indicated below:

i) Surge Protections for Solid State Equipments/ Systems

All solid state systems/ equipments shall be able to withstand the electrical noise and surges as encountered in actual service conditions and inherent in a power plant. All the solid state systems/ equipments shall be provided with all required protections that needs the surge withstand capability as defined in ANSI 37.90a/ IEEE-472. Hence, all front end cards which receive external signals like analog input & output modules, binary input & output modules etc. including power supply, data highway, data links shall be provided with protections that meets the surge withstand capability as defined in ANSI 37.90a/ IEEE-472. Complete details of the features incorporated in electronics systems to meet this requirement, the relevant tests carried out, the test certificates etc. shall be submitted alongwith the proposal. As an alternative to above, suitable class of IEC-255-4 which is equivalent to ANSI 37.90a/ IEEE-472 may also be adopted for SWC test.

- ii) Dry heat test as per IEC-68-2-2.
- iii) Damp heat test as per IEC-68-3.
- iv) Vibration test as per IEC-68-2-6.
- v) Electrostatic discharge tests as per IEC 801-2 or equivalent.
- vi) Radio frequency immunity test as per IEC 801-6 or equivalent.
- vii) Electromagnetic immunity as per IEC 801-3 or equivalent.

Test listed at item no. v), vi), vii) above are applicable for front end cards only as defined under item i) above.



6.13.3 Type Test Requirement for C&I Systems

<u>Sl No</u>	<u>Item</u>	<u>Test Requirement</u>	<u>Standard</u>	<u>Test To Be Specifically Conducted</u>	<u>Approval Req. on Test Certificate</u>	<u>Remarks</u>
1	2	3	4	5	6	7
i)	Narrow chart recorder	As per standard (col 4)	IS9319	No	No	
ii)	Multi point recorder	As per standard (col 4)	IS9319	No	No	
iii)	Vertical indicators	As per standard (col 4)	IS9319	No	No	
iv)	Elect. Metering instruments	As per standard (col 4)	IS-1248	No	Yes	
v)	Transducers	As per standard (col 4)	IEC-688,IS1278 4	No	Yes	
vi)	Thermocouple	Degree of protection test	IS-2147	No	No	
vii)	RTD	As per standard (col 4)	IEC-751	No	No	
viii)	C.J.C.BOX	Degree of protection test Ambient Temp. effect	IS-2147 Approved procedure	No No	Yes Yes	
ix)	Electronic transmitter	As per standard (col 4)	BS-6447 / IEC-770	No	Yes	
x)	E/P converter	As per standard (col 4)	Mfr. Standard	No	Yes	
xi)	Dust emission monitor	Degree of protection test	IS-2147	No	Yes	
xii)	Instrumentation Cables Twisted & Shielded			Yes	Yes	



Section 6 (Control and Instrumentation Works)

a)	Conductor	<ul style="list-style-type: none">○ Resistance test○ Diameter test○ Tin Coating test (drain wire)	VDE-0815 IS-10810	
b)	Insulation	<ul style="list-style-type: none">○ Loss of mass○ Aging in air ovens○ Tensile strength and elongation○ Heat shock○ Hot deformation○ Shrinkage○ Bleeding & blooming	VDE 0472 VDE 0472** VDE 0472** VDE 0472** VDE 0472 VDE 0472 IS-5831	** As per VDE 0207 for teflon insulated cables
c)	Inner sheath	<ul style="list-style-type: none">○ Loss of mass○ Heat shock○ Cold bend/ cold impact test○ Hot deformation○ Shrinkage	VDE 0472 VDE 0472** IS-5831 VDE 0472 VDE 0472	
d)	Outer sheath	<ul style="list-style-type: none">○ Loss of mass○ Aging in air ovens○ Tensile strength and elongation test before and after ageing○ Heat shock○ Hot deformation○ Shrinkage	VDE 0472 VDE 0472** VDE 0472** VDE 0472** VDE 0472 VDE 0472	



Section 6 (Control and Instrumentation Works)

		○ Bleeding & blooming	IS-5831		
		○ Colour fastness to water	IS-5831		
		○ Cold bend/ cold impact test	IS-5831		
		○ Oxygen index test	ASTMD-2863		
		○ Smoke density test	ASTMD-2843		
		○ Acid gas generation test	IEC-754-1		
e)	fillers	○ Oxygen index test	ASTMD-2863		
		○ Smoke density test	ASTMD-2843		
		○ Acid gas generation test	IEC-754-1		
f)	AL-MYLAR shield	○ Continuity test			
		○ Shield thickness			
		○ Overlap test			
		○ Noise interference	IEEE Transactions		
g)	Over all cable	○ Flammability	IEEE 383		
		○ Noise interference			
		○ Dimensional checks	IS 10810		
		○ Cross talk			
		○ Mutual capacitance	VDE-0472		
		○ HV test	VDE-0472		
		○ Drain wire continuity			
xiii)	Pressure gauge	○ Degree of protection test	IS-2147	No	No



Section 6 (Control and Instrumentation Works)

		○ Temp interference test	IS -3624	No	No
xiv)	Temperature gauge	Degree of protection test	IS-2147	No	No
xv)	Pressure & DP switch	○Degree of protection test	IS-2147	No	No
		○As per standard (col 4)	BS 6134	No	No
xvi)	Level switch	Degree of protection test	IS-2147	No	No
xvii)	Conductivity level switch	Degree of protection test	IS-2147	No	Yes
xviii)	Battery charger (Including chargers of UPS)	○Degree of protection test	IS-2147	No	Yes
		○Short circuit current capability	IEC-146-2	No	Yes
		○Temp rise test without redundant fans	Approved procedure, IEC 146-2	Yes	Yes
		○SWC test	Approved procedure, IEC-146-2,IEC146	No	Yes
		○Efficiency / PF	IEC-146-2,IEC146	Yes	Yes
		○Audible noise test	IEC 146-2	No	Yes
		○Fuse clearing capability	Approved procedure	No	Yes
		○Relative harmonic content	Approved procedure	No	Yes
		○Radio interference	IEC 146-4	No	Yes
		○Over Load test on inverter & charger.	Approved procedure	No	Yes



Section 6 (Control and Instrumentation Works)

		○ Restart test	IEC 146-2	No	Yes
		○ Output voltage tolerance	Approved procedure	No	Yes
		○ Output voltage harmonic content	Approved procedure	No	Yes
		○ Insulation test	IEC 146	No	Yes
		○ Load tests	Approved procedure	Yes	Yes
		○ Preliminary light load test	IEC 146	No	Yes
		○ Current division/ voltage division	IEC 146-2	No	Yes
xix)	Battery	As per standard (col 4)	IEC-623 / IS-10918 for Ni-Cd IS-1652 for Plate Lead Acid IS-1651 for Lead Acid	No	Yes
xx)	Control valves	CV Test	ISA 75.02	Yes	No
xxi)	Voltage stabilisers	○ Over load test	Approved procedure	No	Yes
		○ Temp rise test without redundant fans	Approved procedure	No	Yes
		○ Input voltage variation test	Approved procedure	No	Yes
xxii)	Flow Nozzles & Orifice plate	Calibration	ASME PTC , BS 1042	Yes	No
xxiii)	PLCs	All tests as per IEC-1131	IEC-1131		



Section 6 (Control and Instrumentation Works)

xxiv)	DDCMIS				
	a)I/O modules	CMRR & NMRR verification	Mfr standard	No	Yes
	b) Other modules	CMRR & NMRR verification	Mfr standard	No	Yes
	c)CLCS Systems	Model test	Approved procedure	Yes	Yes
xxv)	LIE / LIR / Junction Box	Degree of protection test	IS-2147	Yes	Yes
xxvi)	Flue gas O2 Analyser	Degree of protection test	IS-2147	No	Yes
xxvii)	Flue gas CO Analyser	Degree of protection test	IS-2147	No	Yes
xxviii)	Flue gas SO2 Analyser	Degree of protection test	IS-2147	No	Yes
xxix)	Flue gas NOX Analyser	Degree of protection test	IS-2147	No	Yes
xxx)	Master Slave Clock	Current/ Power efficiency	Approved Procedure IEC 146	No	Yes



STANDARD TECHNICAL SPECIFICATION FOR MAIN PLANT PACKAGE

SECTION- 7

(CIVIL WORKS)

7.1 GENERAL

7.1.1 Intent of Specification

- 7.1.1.1 This section of the specification covers the technical requirements for design, preparation of general arrangement drawings, civil task drawings, construction, fabrication and erection of civil and structural works included in bidder's scope.
- 7.1.1.2 Description of various items of work under this specification and nature of work in detail are given hereinafter. The complete works under this specification is referred to as "Civil Works" including structures, plant, systems, facilities, etc., covered under the scope of this section of the specification.
- 7.1.1.3 The work to be performed under this specification shall also include design, engineering and providing of all labour, materials, plant and equipment for construction, consumables, construction facilities and all incidental items though not specified but are necessary for the completion and proper functioning of the plant, systems and facilities in strict accordance with the Specification.
- 7.1.1.4 All materials required for works under the bidder's scope shall be arranged and supplied by the bidder.
- 7.1.1.5 The work shall be carried out according to the design and drawings, to be developed by the bidder and approved by the purchaser. For all plant, systems, facilities, structures, etc., necessary layout and details are to be developed by the bidder keeping in view the statutory and functional requirements and providing enough space and access for operation, use and maintenance. The bidder's work shall comply with IS codes, requirements of various statutory bodies, international standards, best prevailing practices and to the complete satisfaction of the purchaser.
- 7.1.1.6 The bidder shall make the layout and levels of all structures from the general grid of the plot and the nearest GSI benchmark or other acceptable benchmark of Government Department, as per the directions of the purchaser. The bidder shall be solely responsible for the correctness of the layout and levels and shall also provide necessary instruments, materials, access to works, etc., to the purchaser for general checking of the correctness of the civil works.



7.1.1.7 All the quality standards, tolerances, welding standards and other technical requirements shall be strictly adhered to.

7.1.1.8 The bidder shall fully apprise himself of the prevailing conditions at the proposed site including climatic conditions, monsoon pattern, soil conditions, local conditions and site specific parameters and shall provide for all such conditions and contingent measures, including those which may not have been specifically brought out in the Specification but required for successful execution of work.

The preliminary soil investigation has been carried out and a copy of the report of the soil investigation is enclosed¹ for general guidance to the bidder. However, the bidder shall satisfy himself for prevailing soil condition before making his offer.

7.1.1.9 In case of any conflict between stipulations in various portions of the specification, most stringent stipulation would be applicable for implementation by the bidder.

7.1.1.10 Design documents and drawings

- i) Commencement of fabrication, erection and construction shall be done after approval of the relevant design documents and drawings. All drawings shall be of standard sizes (metric system) and shall be made under AutoCAD, whereas all documents shall be made either in MS Excel, MS Word or MathCAD.
- ii) The design documents and drawings for all the areas, plants, equipment, systems and facilities (including pipes, cables, ducts etc.) included in bidder's scope shall be submitted for approval of the purchaser.
- iii) The design documents and drawings to be submitted by the bidder shall contain at least the following minimum information:
 - a) General arrangement for equipment, piping, cables, ducts.
 - b) Loading plans indicating floor imposed loads, equipment loads and loads due to piping, cables and ducts.
 - c) Openings in floors, walls, cladding, roof.
 - d) Equipment mounting details (where supporting structures are provided by the purchaser).
 - e) General arrangement of foundations including loading data, bolt details, pocket details, etc.
 - f) Insert details, anchor fastener details along with their general arrangements.

¹Preliminary soil investigation report to be enclosed by the purchaser.



- g) Project design intent document covering design criteria including loading assumptions, references, structural idealization/ mathematical model, load cases, load combinations, etc.
- h) Analysis and structural design calculations.
- i) 3-D modeling of structures.
- j) Details of corrosion protection measures.
- k) Architectural drawings.
- l) Any other submission, as indicated elsewhere in this specification and/ or as required by the purchaser.

7.1.2 Scope of Work

7.1.2.1 The scope of civil works for main plant package shall include but not limited to the following:

Preparation of design and construction drawings/documents.

Civil and structural works including supply of all materials (inclusive of loading, unloading), fabrication, execution of work, testing etc. for all buildings, equipment and facilities in main plant area.

Excavation in soil and rock (if any), dewatering, dressing to required profile, sheet piling or shorting/strutting, backfilling around completed structures and plinth filling, disposal of surplus earth and rock.

Foundations including piling, if required.

Concreting including reinforcement and formwork.

Steel structure, fabrication and erection of all structural steel and miscellaneous steel (i.e. steel staircase, cable/pipe supports, trestles, ladders, walkways, railing, chequered plate/grating, inserts, anchor bolts, etc.).

Masonry work, plastering, painting.

Un-insulated/sandwich insulated metal wall cladding.

Roofing including permanent steel decking, water proofing and rain water pipes.

Flooring.

Acid and alkali resistant lining where required.

Doors, windows, ventilators including fire proof doors.

Under deck insulation, false ceiling.

Paving, gravel filling, cable trenches, ducts, covers.



Water supply to buildings, gates/ valves, plumbing work, toilet fittings, water coolers in all buildings.

Sewerage work.

Exhaust fans in all toilets, pantries, kitchen and lift-well etc.

Damp proofing, water proofing of underground structures.

Anti-weed and anti-termite treatment.

Plinth protection.

7.1.2.2 Plant infrastructural works

- i) Geotechnical investigations and detailed survey.
- ii) Site clearance including grubbing, removing of shrubs, trees etc.
- iii) Plant leveling and grading including micro grading.
- iv) Access road from nearest highway² to plant site, plant roads, access roads to various buildings and structures as required.
- v) RCC culverts and concrete pipes for underground facilities.
- vi) Rails for transformer yard and main plant building with RCC foundations.
- vii) Fencing for transformer yard and other areas wherever required.
- viii) Drainage system in main plant area including storm water drainage system upto natural drainage system.
- ix) Concrete paving in main plant building area wherever required.

7.1.2.3 Main plant– turbine island

- i) Main plant building (AB, BC and CD bays) with turbine floor, mezzanine floors, deaerator floor, and various facilities such as unit control room, control equipment room, MCC/ switchgear rooms, SWAS room, battery rooms, cable vaults, air handling unit (AHU) rooms etc.
- ii) Foundations for TG and other equipment.
- iii) Transformer yard.
- iv) Pipe and cable rack structures including foundations.
- v) Pipe and cable trenches.
- vi) Concrete stools/ steel structures for equipment foundation/ mountings, valve operating platforms, access ladders etc.

² Distance to be indicated by the purchaser.



7.1.2.4 Main plant– boiler island

- i) Boiler foundations.
- ii) ESP foundations.
- iii) Foundations for boiler auxiliaries viz. fans, mills and other miscellaneous equipment.
- iv) Duct support foundations.
- v) Mill and bunker bay buildings.
- vi) Raw coal bunkers.
- vii) Pipe and cable rack structures including foundations
- viii) Pipe and cable trenches.

7.1.2.5 Plant auxiliary buildings and pump houses etc.

- i) Service building.
- ii) DG set building.
- iii) ESP and VFD control building.
- iv) Fuel oil pressurizing pump house.
- v) Condensate storage tank foundations.
- vi) Chemicals storage tank foundations.
- vii) Waste neutralizing pit.
- viii) Air conditioning plant building.
- ix) Air washer rooms.

The scope of civil, structural and architectural work given above and hereunder is general in nature. The bidder shall provide all structures/ facilities as required for the effective functioning of various systems of the main plant package.

7.1.3 Design Basis Report (DBR)

- 7.1.3.1 The design basis report shall cover the description of civil/ structural systems and their components, and design criteria for the major components. The contractor's detailed design shall comply with the requirements defined herein for each system. The contractor shall submit the DBR document based on relevant stipulations and design criteria of the



tender specification and giving his own additional design parameters for each building / structure and obtain Purchaser's approval before proceeding with detailed designs.

7.1.3.2 The contractor's detailed design and scope of supply shall include all components and systems, whether included in the system descriptions or not but required to provide a complete and fully functional facility.

7.1.4 Field Quality Plan (FQP)

The contractor shall submit and obtain purchaser's approval of the detailed FQP for workmanship, materials, testing and approval, for each item of civil and structural work, prior to executing the works.

7.1.5 Construction Safety

The contractor shall submit the details of construction safety procedures to be followed at site and also obtain the purchaser's approval for each item of civil and structural works prior to execution of work.



7.2 SITE GRADING, LEVELING, ROADS, STORM WATER DRAINAGE AND LANDSCAPING

7.2.1 Site Grading and Leveling

7.2.1.1 Design criteria

Leveling and grading shall be carried out by selected cutting and filling of existing ground surface and earth. The cutting and filling requirements should balance each other to avoid earth from borrow pits as far as possible. Different grade levels may be adopted for different areas. Following levels may generally be adopted for the plant:-

- | | | | |
|------|---------------------------------------|---|------------|
| i) | Formation level of the plant | : | $\pm 0.0M$ |
| ii) | Road level of the plant | : | $+0.2M$ |
| iii) | Finished floor level of all buildings | : | $+0.5M$ |

Formation level of the plant shall be kept minimum 1.0 m above the highest flood level (HFL).

7.2.1.2 General site excavation and fill

General site excavation and fill shall establish a uniform, stable working surface in active station areas, provide for positive drainage compatible with natural drainage system around buildings and other structures, and provide adequate soil cover for underground utilities. Before the placement of fill material, the existing sub grade shall be prepared as follows:-

- i) All vegetation, organic or otherwise incompetent material shall be removed. The remaining in-situ material shall be compacted to the depth and density determined by the detailed design. Compacted fill material shall consist of specified material obtained from an offsite source if not available within the limits of construction. This material shall be placed and compacted to the density and geometry determined by the detailed design. Slope stability, moisture and density relationship, and compaction requirements shall be determined as a result of the geotechnical field and laboratory investigations.
- ii) Earth material shall be removed to the required lines and grades. Any remaining organic or otherwise incompetent material in an excavation shall be removed if so required. The remaining in-situ material shall be graded and compacted to the depth and density determined by the detailed design. Excavated material shall be used as general site fill or embankment fill provided it meets the necessary design requirements.
- iii) The size of the general site fill is defined by its geometrical boundaries. These shall be established in conformity with the arrangement of site facilities and the site design parameters subject to constraints imposed by the interfacing systems.



- iv) The natural soil strata and fill material shall be tested for presence of sulphates and chlorides. In the event high percentages of such compounds are found to be present, required special treatment/coatings shall be provided to the concrete and reinforcement surfaces for foundations and structures below ground for protection against the deterioration during the life-time of such structures.

7.2.1.3 Structure backfill

- i) Structure backfill shall provide stable fill around and adjacent to structure foundations and buried utilities.
- ii) All organic and other existing material which can cause settlements due to soil volume change shall be removed prior to placing the fill material. Backfill shall be placed and compacted to the required limits. The use of heavy equipment or inundation for placing structure backfill shall be prohibited.
- iii) The extent of structure backfill shall be determined by the fill requirements for the various structure foundations.
- iv) Material selection criteria for structure backfill shall be as described in general site excavation.

7.2.1.4 Slope protection

- i) Slope protection shall protect earth slopes from erosion due to storm water runoff and wind damage or other natural phenomena.
- ii) All earth slope surfaces subject to erosion shall be provided with slope protection. Slope protection shall consist of grass cover, grout filled fabric forms riprap, or other effective slope protection methods. The type of slope protection shall be determined by the expected velocities of storm water runoff and any other appropriate factors and shall be subject to the purchaser's approval.
- iii) The extent of slope protection shall be defined by the amount of earth surface subject to erosion and the type of erosion present. The material shall be sound, durable, and able to resist the effects of abrasion.

7.2.2 Roads

7.2.2.1 Design criteria

- i) The roads system shall provide vehicular access throughout the plant area including access to all building and structure etc. The system shall provide access to all building and major activity areas of the site.
- ii) The roads system shall be subjected to heavy vehicles and construction equipment during construction. All roads shall be subject to heavy wheel loads of off-road haul trucks, wheel loaders, and scrapers. Road system shall be designed for minimum



class 'A' loading or higher conforming to IRC standards. All roads should be provided with adequate camber as per IRC standards.

- iii) The roads shall be divided into two types of roads as follows:-
 - a) All main plant roads shall be 10 meter wide with raised foot path on both sides of roads.
 - b) All secondary plant roads shall be 4.5 meter wide provided with 1.5 meter wide hard shoulders on either side and shall be for access to plant auxiliary areas and buildings. Peripheral road along the boundary wall shall have adequate nos. of watch towers as per requirement.
- iv) Secondary access roads within the station complex shall be constructed during the site preparation phase of construction with RCC culvert at road junctions to cater for crossing of drains/cables etc. to avoid major road cuttings at a later date.
- v) All roads shall be constructed on prepared sub-grade and stone sub-base and base of two (2) layers of water bound macadam each of minimum 75 mm thickness, with Gr. II crushed rock aggregate conforming to IRC-19 laid over prepared sub-base. The sub-grade for the road shall be the natural ground, which shall be cleared of all loose material, organic matter, grass etc, scarified, rolled and compacted to proctor density of 95%. The sub-base shall consist of crushed stone laid to a minimum thickness of 200 mm, in 2 layers of 100 mm compacted thickness each, with Gr. I aggregate conforming to IRC-19. All the roads shall be topped with Asphalt concrete 50 mm minimum thickness Road side drainage shall be provided preferably on both sides of road. The total thickness and composition of the layers of the pavement shall be provided as per IRC standards.

7.2.2.2 Road sub-grades

- i) The sub-grades shall provide uniform and stable foundations for the roads.
- ii) Prior to construction of road sub-grades, all existing vegetation, organic or otherwise incompetent material, shall be removed. The remaining in-situ material shall be graded and compacted to the depth and density determined by the detailed design prior to the placement of fill material. During excavation, earth material shall be removed to the required lines and grades, any remaining organic or otherwise incompetent material shall be removed. The remaining in-situ material shall be graded and compacted to the depth and density determined by the detailed design before proceeding with the sub-grade construction.
- iii) Embankment fill material shall consist of specified fill material obtained from excavation at other onsite grading areas, buildings, or roadbeds. This material shall be placed and compacted to the density and geometry determined by the detailed design to provide the strength required and to limit settlements within the allowable limits. Slope stability, moisture and density relationship, and compaction requirements shall be determined based on results of geo-technical field and laboratory investigations.



- iv) Borrow material in excess of that provided by the sources described above shall be obtained from borrow areas or from an offsite source if not available within the limits of construction.
- v) Sub-grade excavation shall be accomplished in the same manner as for general site excavation.
- vi) The sizing criteria and material selection criteria for road sub-grades shall be as described in general site excavation.

7.2.3 Grading and Storm Water Runoff Drainage

7.2.3.1 Design criteria

- i) Grading shall provide stable sub-grades for transportation facilities, flow ways for the transportation of runoff, flood protection, and stable earth surfaces for access and for handling of materials during plant construction and operation.
- ii) Storm water runoff drainage shall direct runoff from roof drains and other areas to the proper drainage collection basins or to natural drainage as appropriate. Rainfall runoff shall be directed from facility areas and construction lay-down areas in a manner which allows maximum freedom of vehicular traffic patterns.
- iii) Various classes of compacted earth fill materials with stone base shall form roadbed embankments, foundation bearing surfaces, and stable earth surfaces for access roads and parking areas.
- iv) Grading and engineered ditches shall direct the site drainage. Roof drainage and ditch flow shall be based on a 1 in 50 year frequency rainfall event for the power block area, the railroad, and for the plant access roads.
- v) Whenever possible, drainage shall run parallel to roadways and traffic areas to direct runoff to culverts used in the storm water runoff drainage system.
- vi) In case collection basin is provided, the basin shall be designed to contain general site drainage, neutralization basin flows, oil/water separator flows, and service water system flows, septic tank. The basin shall be sized to contain the 24 hours storm runoff from two recent consecutive rainfall events and shall be designed not to have a normal discharge.

7.2.3.2 Storm water runoff drainage and culverts

Offsite runoff entering the site from surrounding areas shall be routed around the site area through the use of overland flow, open channel flow, and underground piping. Runoff originating from areas of the site not disturbed by construction activities or unit operation shall be allowed to flow to the natural site drainage system. Runoff from disturbed areas of the site shall be controlled as described below:-



- i) Open areas shall be sloped a minimum of 1 percent to drain away from buildings and structures towards drainage channels. All runoff shall be conveyed by gravity to the drainage system. Open drains shall be utilized primarily except for roof and floor drainage. In areas where surface space limitations prevent the use of open drains, catch basins/pits shall be used. Catch basins shall discharge to the nearest open drain through underground piping. RCC box culverts/pipe culverts shall be used to pass flows under roads, railroads, and other locations where surface conveyance would not be practical. For pipe culverts, reinforced concrete pipes class NP3 conforming to IS-458 shall be provided. For all other underground piping work reinforced concrete pipe class NP2 of IS-458 (minimum) shall be provided.
- ii) All plant drains shall be of covered RCC construction and shall be rectangular in shape. Drains shall be provided with RCC slab covers if required from aesthetic and operational requirements. MS edge angles shall be provided on the drain side walls supporting the cover slabs. The pre-cast cover slabs shall also be provided with MS flats/angles for edge protection. All culverts shall be equipped with headwalls and aprons at both the upstream and downstream ends. Wherever vehicular or other loading is anticipated to occur over drain covers, these shall be designed for it.
- iii) The general site drainage system shall be designed for a 1 in 50 year frequency rainfall event for the power block area and for the main access roads.
- iv) Culvert wall thickness shall be sized to provide adequate strength and allow for corrosion protection over the unit lifetime. The opening shall be sized to carry the design flow most efficiently accounting for the constraints of the discharge channel and the embankment.
- v) All runoff from outside area flowing through the site shall be suitably diverted to the natural drainage system by constructing the open channels, underground pipes or closed channels as per site requirement. The natural drainage system may need to be modified to take care the additional discharge from the site/

7.2.3.3 Road drainage

- i) Runoff from onsite road roadbeds and other embankments shall be collected and directed to general site drainage. Roads and their embankments shall be sloped to drain to toe drains which shall collect and transport the runoff. Intermediate culverts shall convey runoff through embankment fills.
- ii) Toe drains and culverts shall be designed as described in general site drainage. Drainage system study within plant boundary as well as outside the plant boundary shall be carried out.



7.2.4 Landscaping and Ground Cover Design Criteria

- i) The landscaping and ground cover system shall enhance the appearance of selected areas, enhance soil and slope stabilization on the generating station, and assist in reducing the noise level and fugitive dust generated by the plant.
- ii) The landscaping system shall include a routine maintenance program. Expected maintenance for the area shall be as follows:-
 - Disease and insect control for plant material and turf.
 - Weed control.
 - Fertilization.
 - Mowing and trimming.
 - Pruning.
 - Watering.
- iii) Landscaping and stabilization of the site should begin after excavation, trenching, backfilling, rough grading, surfacing, and paving have been completed. Slopes of three-to-one (3:1) or steeper shall be stabilized as soon as possible after final grading.
- iv) Landscaping operations shall be confined within areas which have been disturbed by construction activities.
- v) The ground cover areas shall be seeded with native grasses. Establishment of the cover areas shall include preparation of the soil surface, fertilizing, planting, covering and firming the seed to the soil, mulching, watering, and maintenance of the disturbed areas. Grasses for the ground cover shall be selected for drought tolerance and low maintenance.
- vi) A sufficient water and irrigation system shall be provided to service all landscaping and ground cover.



7.3 BUILDINGS AND STRUCTURES- MAIN PLANT

7.3.1 General

All buildings and steel structures to be provided shall be normally subjected to corrosive environment. All materials for concrete and steel structures, fixtures and fittings shall therefore be selected so as to withstand such corrosive environment. The buildings and structures system shall consist of the following specific areas.

7.3.2 Buildings

i) Main plant building

The main plant building shall consist of AB-BC-CD bays having turbine, generator, auxiliaries and electrical and C&I equipment with appropriate length and width. The building shall be structural steel framed consisting of columns and beams, and provided with RCC floors and roof at appropriate levels as per design requirement. Adequate ventilation and access shall be provided by doors and windows located at different elevations. The building walls shall be of brick masonry, plastered on both faces and painted.

The unit control room, control equipment rooms, shifts room, engineer's room shall be provided with false ceiling and false floor as required. The flooring shall be with PVC antistatic tiles. The control rooms shall be provided with full length glazing and glazed partitions and shall be fully air-conditioned. Standard aluminum sections shall be provided for glazed doors and partitions. An express laboratory along with centralized water-steam quality monitoring system shall also be provided on the operating floor.

ii) Bunker and mill bay building

The bunker and mill bay shall be a structural steel framed structure of appropriate length and width, having RCC floors and roof at required levels as per design requirements. The traveling conveyor (purchaser's scope) shall be located above the coal bunkers. Coal mills shall be located in this bay. Bunker shall be made of mild steel (MS) and shall be preferably of circular shape with conical hopper. The hopper portion shall be made of MS with minimum 4mm SS304 lining. Storage capacity of the bunkers shall correspond to 14 hours requirement of the unit under BMCR condition with worst coal firing.

iii) Electrostatic precipitators (ESP) structures

The Electrostatic precipitator structures shall provide support to the ESP equipment necessary for particulate removal from the steam generator gas emissions. External platforms shall be provided at various levels as per operation and maintenance requirements. Access to the external platform shall be from the internal staircase. Platforms shall be provided with steel grating or chequered plate for access up to the roof of each ESP.



In addition to ESP structures, an enclosed ESP control room building shall be provided for each steam generator to locate the panels and control equipment of ESP and VFD for ID fans, if applicable.

Each of the ESP control room buildings shall be RCC framed building with brick walls plastered on both faces, complete with drains, space conditioning, and building lighting. The building shall have a separate air-conditioned area; and a separate non air-conditioned area except as required for the contained equipment.

iv) Service building

This shall be a four storey RCC structure having 3000m² plinth area. This building shall be centrally air conditioned. This building shall be air conditioned and shall house O&M staff, laboratories, etc. Layout and plan of the building shall be got approved by the purchaser during detailed engineering.

v) Miscellaneous buildings

Miscellaneous buildings such as DG set room, A/C plant room, air washing unit room, fuel oil pump house, etc. as required shall be provided.

7.3.2.2 The following description applies to specific architectural components in the main plant building:-

i) Base wall

In the general area of the transformers, the base wall shall be of cast-in-place concrete for fire and explosion protection of the main plant building.

ii) Exterior wall

Provisions shall be made for wall areas requiring periodic, temporary removal such as the condenser tube-pull area. Noise control shall be ensured for turbine area to have a minimum noise reduction coefficient (NRC) of 0.80.

iii) All the office laboratory and control room areas shall be provided with acrylic emulsion paint on inside of plastered brick masonry walls duly prepared with acrylic block filler base. All external brick masonry walls shall be provided with approved type of painting/coating conforming to table 7-2 of the specifications.

7.3.2.3 The following descriptions shall apply to specific access components in the main plant building:-

i) Stairs

At least one (1) number each full height stair towers shall be provided for each unit. These shall be provided in each of the areas as required. Additional stairs and



platforms shall be provided for access to equipment as required for operation and maintenance. Additional stairs shall be provided for access to the control rooms and plant services areas to provide additional access between floors.

ii) Doors

Personnel access doors, fire proof doors and electric operated rolling metal doors shall be provided in the main plant building as determined during detailed design based on equipment requirements.

iii) Floors

The following areas shall consist of a concrete slab:-

- a) All electrical equipment rooms, control rooms and electrical equipment support areas.
 - b) The operating floor of the turbine generator area which shall consist of a structural slab with an approved concrete finish.
 - c) The coal feeder support areas; and coal tripper support areas.
 - d) Elevator machinery rooms.
 - e) Grade slab (+0.00)
- iv) Additional areas shall be determined for the requirement of concrete slabs during the detailed design. All remaining areas in the main plant building shall utilize grating/concrete as per design requirement.
- v) The main plant building shall be complete with drains, toilets, plumbing, sanitary drainage and treatment piping, space conditioning for air-conditioned areas, and evaporative cooling plant for non air conditioned areas of the main plant building and service building; building lighting, station communications, and fire protection. Space conditioning for an air-conditioned area shall be provided in the control rooms, computer rooms etc as well as plant services areas. Space conditioning shall not be provided in the steam generator areas.



7.4 DRAINS AND PLUMBING

7.4.1 General

The drains and plumbing system shall carry contaminated and other waste fluids by gravity to a waste collection and treatment system through an over ground piping system and embedded underground pipes.

7.4.2 Major Components

The drains and plumbing system shall consist of the following major components:-

- i) Roof drains.
- ii) Trenches, floor, equipment, and oil drains.
- iii) Hot drains.
- iv) Plumbing.

7.4.3 Description

- i) The drains and plumbing system shall consist of drain trenches covered with pre-cast RCC covers or gratings, floor drains, feeder drain pipes, down comers, bell-ups, inspection chambers/manholes with covers, main pipe headers, and supply piping. This system, along with the interfacing waste collection and treatment systems shall drain the floor drains and fixtures to the proper drainage or treatment facility.
- ii) All components of the drains and plumbing system shall be designed to ensure efficient drainage of the associated areas or equipment.
- iii) The water or storm drainage facilities and piping shall be located at elevations to allow gravity drainage adequately.

7.4.4 Roof Drains Design Criteria

- i) The roof drains shall transport rainfall runoff from roofs to the grading and storm water runoff drainage system.
- ii) The roof drains shall consist of roof drain assemblies, feeder pipes, horizontal drain headers, vertical down comers, roof drain bell-ups, and embedded roof drain pipe. Rain water vertical down comer pipes shall be of cast iron.
- iii) The roof drains shall be sized for the roof area runoff for a maximum rainfall per hour at site. Fixing of rain water gutters and down pipes for roof drainage shall conform to IS-2527.



7.4.5 Trenches, Floor, Equipment and Oil Drains Design Criteria

- i) The floor and equipment drains shall drain effluent from fire water, equipment leakage, and water from hydrostatically tested systems, and drain areas that have been washed down during maintenance operations.
- ii) The oil drains shall convey spilled oil residue from lube oil storage tanks, lube oil reservoirs, equipment with lube oil packages, and other areas where oil exists. This system shall not be used to drain the equipment. Oil drains shall be collected separately and treated.
- iii) Oil drains shall direct oil residue to an oil separator where the oil shall be removed before the remaining fluid enters the wastewater collection and treatment system.
- iv) The floor drain shall consist of a drain bell-up and the drain pipe which shall be supported by the structural concrete, suspended slab concrete, or steel. Trenches located in foundations shall have grating covers. Concrete edges/ corners of drains shall be provided with edge angles of minimum size 50x50x5 with lugs for edge protection. All floor drains shall discharge into the grading and storm water runoff drainage system or the appropriate waste collection and treatment system.
- v) The emergency ash pit floor drains shall be routed to a sump in the ash pit located in the vicinity of the bottom ash hopper.
- vi) All drains shall be of minimum 100 mm diameter. Manholes and inspection pits with covers shall be located at bends, junctions and in other areas as per design requirements. The horizontal lines shall be sloped as determined during detailed design subject to applicable codes and standards.

7.4.6 Hot Drains Design Criteria

- i) The hot drains shall accept discharges from the blow down tanks, water heaters, and other equipment using hot water, and shall transport the fluids to the wastewater collection and treatment system.
- ii) Interfacing systems shall discharge into the hot drains at the ground floor. The above floor hot drains shall discharge into the embedded hot drains at bell-ups located in the foundation concrete mat; and shall be transported to a manhole.
- iii) The size of the hot drains shall be determined during detailed design based upon the requirements of the components draining to the system.

7.4.7 Plumbing Design Criteria

- i) The plumbing shall consist of all the hot and cold water supply distribution piping from the potable water header connection to and including the plumbing fixtures. The plumbing fixtures shall include water heaters, lavatories, urinals, toilets, etc. The plumbing shall be rigidly anchored to walls and steel with suitable pipe hangers



or wall brackets. All plumbing materials and fixtures shall be of the best quality and make conforming to relevant IS codes with water conserving features and shall be as approved by Purchaser.

- ii) The plumbing shall be sufficient to supply the quantity of water required by the plumbing fixtures. All plumbing work shall correspond to IS-2065 and IS-1172.
- iii) The design, layout, construction etc of drains for waste-water, surface water and sewage together with connections, manholes, inspection chambers etc., used within the building and from the building to the septic tank or treatment works shall conform to IS-1742.

7.4.8 Sanitary and Plumbing Fittings

- i) All sanitary fittings and plumbing fixtures shall be of the best quality and make with water conserving features, and shall be subject to purchaser's approval. All water supply fittings in toilets, kitchen etc viz., bib cocks, pillar cocks, P-traps, towel rail, shower rose, gratings etc., shall be of best quality chromium plated brass of approved make.
- ii) All water supply pipes for internal plumbing of buildings shall be of GI pipe of medium class conforming to IS-1239 of approved make. Galvanising of pipes shall conform to IS-4736.
- iii) Two numbers of roof water tanks (one for storing service water and another for potable water) of adequate capacities depending on the number of users and 8 hours requirement shall be provided for each building and pump house. Polyethylene water storage tanks conforming to IS: 12701 shall be used. The tanks shall be complete with all fittings including lid, float valve, stop cock, vent pipe, etc.
- iv) Galvanized MS pipe of medium class conforming to IS: 1239 shall be used for internal piping works for service water and potable water supply. The pipes shall be concealed, and painted with anti-corrosive bituminous paint (as per IS: 158) wherever required.
- v) Sand cast iron pipes with lead joints conforming to IS: 1729 shall be used for sanitary works above ground level.
- vi) Minimum one number main toilet block each (for male and female) with required facilities shall be provided on each floor of main plant building, and service building. Attached toilets shall be provided for all senior executive rooms and conference rooms. All other buildings shall have minimum one toilet block each. The facilities provided in the toilet block shall depend on the number of users.



However, minimum facilities to be provided shall be as stipulated in subsequent clause no. 16.02.02, IS: 1172 shall be followed for working out the basic requirements for water supply, drainage and sanitation. In addition, IS: 2064 and IS: 2065 shall also be followed.

- vii) Each toilet block shall have the following minimum facilities. Unless specified, all the fittings shall be of chromium plated brass (fancy type).
- a) WC (Indian type, Orissa pan (580 x 440mm) as per IS: 2556 (Part - 3) with all fittings including flushing valve of appropriate capacity and type.
 - b) Urinal with all fittings with photo voltaic control flushing system as per IS: 2556 (Part-6, Section 1).
 - c) Wash basin (oval shape) with all fittings as per IS : 2556 to be fixed on concrete platform finished with 20mm thick polished granite stone and float glass mirror (600 x 450 x 5.5mm) with beveled edges.
 - d) Stainless steel towel rail (600 x 20mm).
 - e) Stainless steel liquid soap holder cum dispenser.
 - f) Janitor space.
 - g) Provision for installation of water cooler with recessed floor and stainless steel grating for draining of spillage water, including provision for potable water supply connection.
 - h) Electric operated hand dryer with photo voltaic control.
- viii) Attached toilets provided for senior executive rooms shall have one WC, wash basin (oval shape) with all fittings as per IS : 2556 to be fixed on concrete platform finished with 20mm thick polished granite stone and float glass mirror (600 x 450 x 5.5mm) with beveled edges, one towel rail, one liquid soap holder cum dispenser with all fittings. WC shall be of western type 390 mm high as per IS: 2556 (Part-2) with toilet paper roll holder and all fittings including flushing valve of appropriate capacity and type. Unless specified all other fitting and fixtures in the toilet shall have same specifications as stipulated in above clause.



- ix) Ladies toilet shall be provided at main plant ground floor level, main control room level and in service building. It shall consist of one WC (European type) and one counter top washbasin.
- x) Pantry space of adequate size shall be provided at main control room level and in service building.
- xi) In addition to the facilities stipulated elsewhere, following facilities shall also be provided in toilet at ground and operating floor of main plant:
 - a) Bathroom with rotating type chromium plated shower including all fitting and fixtures.
 - b) Toilets in control rooms at main plant operating floor and all toilet blocks in service building shall be provided with wall to wall mirror of entire counter length (5.5 mm thick float glass, minimum height 900 mm) in place of 600x450x5.5 mm mirror above wash basin counter.
- xii) An eye and face wash fountain (combined unit with receptacle) conforming to IS: 10592 shall be provided in acid type battery room.
- xiii) Stainless steel kitchen sink of size 610x510x200 mm as per IS:13983 shall be provided in pantry. Platform in pantry shall be finished with 20 mm thick polished granite stone of approved shade and color.
- xiv) Laboratory sink shall be of white vitreous china of size 600x400x200 mm conforming to IS: 2556 (part-5).



7.5 CIVIL/ STRUCTURAL DESIGN CRITERIA

7.5.1 Introduction

This section describes the design criteria specification and acceptance criteria for materials and workmanship for all civil, structural, and architectural work related to this project.

7.5.1.1 Codes and standards

All materials, design, workmanship test and acceptance criteria etc., must conform to the latest edition of the Indian codes and standards or other Internationally accepted standards which ensure a quality equal to or higher than the Indian standards unless otherwise specified in the specification:-

Indian Standards

- Different Indian standard codes (IS)
- Special publications (SP)
- Indian Road Congress standards (IRC)
- National Building Codes (NBC)

If any, standard/ clauses of the standard contains a provision which is inconsistent with a provision in Indian standard, the more stringent requirement as per the interpretation of the Purchaser shall prevail. All work shall be carried out on the basis of latest edition of applicable codes and standards mentioned.

7.5.2 Natural Phenomena Design Criteria

The design criteria based on the natural phenomena are discussed below.

7.5.2.1 Wind speed

The basic wind speed shall be based on IS: 875 (part 3). This basic wind speed shall be used to determine wind load for all structures.

7.5.2.2 Temperature

Systems and system component design criteria which require ambient temperature extremes shall use the range from minimum to maximum temperature existing at site for dry-bulb temperatures.

7.5.2.3 Relative humidity

- i) Absolute maximum : 100%
- ii) Highest monthly mean : As per site condition



7.5.2.4 Seismicity

The zone factor as per IS: 1893 shall be applied for the plant site.

7.5.3 Design Loads

Design loads for all structures shall be determined according to the criteria described below, unless the applicable Indian building code requires more severe design conditions.

7.5.3.1 Dead loads

Dead loads shall consist of the weights of the structure and all equipment of a permanent or semi-permanent nature including tanks, silos, bins, wall panels, partitions, roofing, piping, drains, electrical trays, bus ducts, and the contents of tanks measured at full capacity. However, the contents of tanks and other loads of semi-permanent nature shall not be considered as effective in resisting column uplift, overturning and sliding.

7.5.3.2 Live loads

- i) Live loads shall consist of uniform live loads and equipment live loads. Uniform live loads are assumed unit loads which are sufficient to provide for movable and transitory loads, such as the weight of people, portable equipment and tools, plank-ing and small equipment, or parts which may be moved over or placed on floors during maintenance operations. These uniform live loads should not be applied to floor areas which shall be permanently covered with equipment.
- ii) Equipment live loads are calculated loads based upon the actual weight and size of the equipment and parts to be placed on floors during dismantling and maintenance, or to be temporarily placed on or moved over floors during installation.
- iii) Floors and supporting members which are subject to heavy equipment live loads shall be designed on the basis of the weight of the equipment in addition to a uni-form load of 500 kg/m^2 , or specifically defined live loads, whichever is greater. Each member in the floor which may carry these loads shall be designed for the heaviest piece or pieces of equipment arranged in the most critical position. For loads caused by moving equipment over the floor for installation, consideration shall be given to the shoring of beams and floor from floors below. When moving equipment over floors for installation, stress increases of 25 percent are permitted in beams and columns.
- iv) Live loads shall be used as follows:-

S. N.	Description	Floor slabs
a)	Grade floors slabs	1500 kg/m^2 (minimum)
b)	Maintenance area in ground floor	3000 kg/m^2

S. N.	Description	Floor slabs
c)	Storage areas	Actual load of stored material or 1500 kg/m ² (minimum)
d)	Suspended floors and control room floor	1500 kg/m ² (minimum) or actual whichever is higher
e)	Turbine generator lay down area	Load as given by TG supplier but not less than 3000 kg/m ²
f)	Roofs (concrete slab)	250 kg/m ²
g)	Steel grating / chequered plate platforms	- 750 kg/m ² for grating/ chequered plate - 500 kg/m ² for supporting beams

Areas designated for different loadings on the same floor shall be clearly and permanently marked.

v) Column live loads

Live loads carried from the floors to the columns shall include 100 percent of the roof live load. In addition to the roof live load, the columns must carry floor live load. If the floor live load is 500 kg/m² or less, no reduction in live loads carried from the floors to the columns is allowed. If the floor live load is greater than 500 kg/m², reduction in live loads carried from the floors to the columns shall be considered as per clause 3.2 of IS-875 (Part-2) for design. However, reduction in live load from all floors to be carried by the member under consideration shall not exceed 20% irrespective of the codal provisions.

vi) Impact loads

Impact loads shall be added to other loads for components supporting reciprocating or rotating machines, elevators, hoists, cranes, or other equipment creating dynamic forces. The following impact loads shall be used, unless analysis indicates higher or lower values:-

- | | | | |
|----|---------------------------|----|---|
| a) | Elevators | -- | 100 % of lifted load. |
| b) | Hoists and cranes: | | |
| | • Vertical | -- | 25 % of the maximum static wheel load. |
| | • Horizontal-lateral | -- | 20 % of the sum of the lifted load plus the weight of the hoisting component. |
| | • Horizontal-longitudinal | -- | 10 % of the total moving load. |



- c) Railroads and roadways -- 20 % of the wheel or crawler loads.
 - d) Rotating and reciprocating equipment -- 50 % of the machine weight
 - e) Hangers supporting floors and platforms -- 33 % of the sum of the dead load and reduced live load.
 - f) Steel members supporting boiler drum hangers -- 100 percent..
- vii) Pipe hanger loads
- a) Pipe hanger loads for the major piping systems, such as the main steam, reheat steam, feed water and extraction systems, shall be specifically determined and located. Piping expansion and dynamic loads including thrust loads at bends shall be considered on an individual basis for their effect on the structural systems. Loads imposed on perimeter beams around pipe chase areas shall also be considered on an individual basis.
 - b) Piping loads to account for miscellaneous piping systems shall initially be estimated as uniform loads per unit floor area based on the expected density and size of piping being supported in a specific floor area. These loads shall be carried to the columns and foundation as dead loads, but shall not be considered as reliable dead load for uplift. In addition to the uniform area load, a concentrated "phantom" load shall be placed on all primary beams for the purpose of sizing the member. This load shall not be carried over to the sizing of other members. The magnitude of the phantom load shall be based on the mechanical piping purchaser's experience for the miscellaneous piping systems to be routed in a specific floor area. After the piping systems have been routed and the piping analyses are complete, the structural support system shall be evaluated for the actual pipe hanger loads plus additional load to account for field routed piping.
- viii) Equipment loads
- Equipment loads shall be specifically determined and located. For major equipment, structural members and bases shall be specifically located and designed to carry the equipment load into the structural system. For equipment weighing less than the live load, the structural system shall be designed for the live load. Equipment loads shall be noted in the design calculations to permit separation in calculation of uplift and stability.
- ix) Access walkways, stair, handrails, and ladders

Design loads shall conform to the requirements of IS: 875 (part I and II) and the minimum requirements following, whichever are the most severe:

- a) The walkways shall be designed for the dead loads of the structure plus a superimposed live load of 500 kg/m² uniformly distributed, or a concentrated load of 500 kg at any point, whichever produces the most severe effect.
 - b) Stair treads shall be designed for a distributed load of 225 kg/linear meter of tread width or a concentrated load of 100 kg, whichever produces the most severe effect.
 - c) Handrail forces shall be 100 kg applied outward at the center of the span and vertical between posts. Ladders shall be designed to withstand a line load of 100 kg or, alternatively, a number of line load units of 100 kg, the number of units and their spacing being in accordance with the anticipated usage of the ladder.
- x) Test load

The test load shall be defined as the gravity load imposed by method necessary to test vessels, tanks, equipment or piping.

7.5.3.3 Wind loads

Wind load for all structures shall be based on IS: 875 (part 3). Basic wind speed shall be as specified in IS: 875(part-3).

7.5.3.4 Seismic loads

The seismic risk zone for the site shall be determined from the IS: 1893. Under seismic condition, the whole frame except the roof shall be assumed loaded with 50% design live load. No further reduction in column live load shall be considered as per clause 5.3.2.1 under seismic condition.

7.5.3.5 Construction loads

The integrity of the structures shall be maintained without use of temporary framing struts or ties and cable bracing insofar as possible. However, construction or crane access considerations may dictate the use of temporary structural systems. Special studies shall be made and documented to ensure the stability and integrity of the structures during any periods involving use of temporary bracing systems.

7.5.3.6 Estimated loads

Loadings imposed by equipment shall be specifically determined or estimated before detailed structural design. Estimated loadings shall be noted as such in hand calculations or computer input and verified as information is made final.



7.5.3.7 Wheel and crawler loads

Loads exerted on bridges, roadway pavements, parking and unloading areas, buried piping, box culverts, and embankments shall be reviewed and selected prior to design of the underlying items. The loads as recommended for IRC class loading shall be utilized for the design of bridges, roadways, and parking and unloading areas. However, where appropriate, loadings such as loaded scrapers, crawler cranes, stator transport trailers, etc., might exceed these loadings and therefore must be considered.

7.5.3.8 Dust loads

All buildings and structures shall be designed for a dust load of 50 kg/m^2 .

7.5.3.9 Loads on underground structures

In addition to other loads, the following loads shall also be considered for underground structures:-

i) Earth pressure

Earth pressure for all underground structures shall be calculated using co-efficient of earth pressure at rest, co-efficient of active or passive earth pressure (whichever is applicable).

ii) Ground water pressure

Ground water pressure due to the highest water table at the location shall be considered.

iii) Surcharge load

Minimum surcharge load of 20 kN/m^2 shall be considered for the design of all underground structures located in the vicinity affected by vehicular traffic; including channels, sumps, cable and pipe trenches etc to provide for increase in earth pressure due to vehicular traffic.

7.5.3.10 Thermal load

Thermal loads shall be defined as forces caused by changes in temperature. The primary source of thermal loads in an industrial plant is the expansion or contraction of vessels and piping. Another source of thermal loads in a redundant structure is the expansion or contraction of the entire structure or individual structural components.

7.5.3.11 Hydrostatic load and buoyancy

Hydrostatic load is the load due to water pressure. The design of structures shall include hydrostatic loads when applicable. The buoyancy load is equal to the weight of the volume of displaced water.



7.5.3.12 Dynamic loads

Each structure shall be designed to withstand the effects of vibration and impact to which it may be subjected. Each structure and foundation supporting a compressor, turbine, pump or other machinery having significant dynamic unbalance shall be designed to resist the peak loads specified by the manufacturer. Vibration amplitudes of the supporting structure or foundation shall be kept within acceptable limits for dynamic forces that occur during normal machine operation. In the case of a tall and slender structure, there may be a need to investigate the dynamic effects of wind gusts.

7.5.3.13 Future load

Loads from future expansion shall be considered when so directed by the purchaser. Future loads may include any of the loads listed above.

7.5.3.14 Surge load

Surge loads may occur in some vessels or equipment. In such cases, the magnitude and direction of the load shall be given by the equipment supplier.

7.5.3.15 Miscellaneous load

Miscellaneous loads shall be defined as loads that do not fit into the categories listed in this section. Typical miscellaneous loads are loads, during erection, maintenance and repair or forces due to creep, shrinkage or settlement.

For the design of individual structural components, realistic load combinations in accordance with the relevant design standards shall be considered.

All loadings considered in the design shall be justified with supporting details.

7.5.4 Special Requirements of Design to Avoid Corrosion Problems

7.5.4.1 General

In case, aggressive soil conditions are revealed in detailed soil investigations and whenever structures are likely to be exposed to corrosive environment due to storage of chemicals or due to any other reasons, special measures are required to be taken care of as given below.

7.5.4.2 Reinforced concrete

- i) The most common type of failure of reinforced concrete is that of corrosion of the embedded reinforcing steel due usually to penetration of chlorides into the concrete.

- ii) Special design aspects have to be considered by the contractor depending upon severity of site conditions, one or combination of following may be adopted.

In order to control the size and mitigate the occurrence of the cracks and to ensure concrete durability, the contractor shall implement the following design requirements:

- a) Use smaller reinforcing bars well distributed over the zone of maximum concrete tension;
 - b) Increase minimum cover on all reinforcing steel;
 - c) Use Portland cement conforming to the requirements of IS:12269;
 - d) Use very dense, low water to cement ratio (i.e. 0.40 ± 0.02) concrete;
 - e) Use synthetic fibres to minimize surface shrinkage cracks;
 - f) Provide foundation tanking and/or surface coating;
 - g) Provide strict measures for concrete curing to prevent plastic shrinkage and thermal gradients resulting from early age heat of hydration of fresh concrete;
 - h) Protect inserts, anchor bolts and all steel items embedded in the concrete from corrosion;
 - i) Prevent the usage of steel profiles in small concrete sections;
 - j) Identify clearly the locations of the construction joints as well as their surface preparation in the drawings;
 - k) Give special consideration for the protection of concrete surfaces subject to high temperatures during plant operations.
- iii) Depending on the place of use, the special corrosion protection measures for reinforced concrete shall be as follows:-
- a) Underground concrete exposed to aggressive soil/water conditions, if so revealed as per site soil investigation. One or combination of following depending upon severity of site conditions may be adopted:
 - Minimum concrete cover 75 mm.
 - Epoxy coated reinforcement bars.
 - Outside tanking protection by PVC sheet membranes with membranes extending 15 cm above ground level.



- b) Foundations for equipment, pipe racks, etc situated outside, but without exposure to chemicals, sea water etc. One or combination of following depending upon severity of site conditions may be adopted:

Minimum concrete cover 50 mm.

Microsilica additions.

Below ground outside protection by PVC tanking membranes with membranes extending 15 cm above ground level.

Above ground outside protection of concrete by epoxy coating (silane siloxane type, which consists of a primer penetrating into the concrete and a compatible top coat).

- c) Concrete exposed to chemicals:

- Same measures as for item (ii) above.
- Acid/alkali resistant tiles fixed with acid/alkali resistant mortar and grouted with acid/alkali resisting grout.

7.5.4.3 Steel structure

- i) All steel members of buildings and structures shall be provided with suitable protective coating. The minimum maintenance free life of protective coating shall be ten years. For sheltered structures where sides are not fully covered such as deaerator floor, bunker building etc., both exterior and interior of structure shall be considered as exposed to non-polluted inland atmosphere condition. For other structures exterior of the structure shall be considered as exposed to non-polluted inland atmosphere condition and interior of the structure shall be considered as normally dry condition. Minimum 75 micron DFT of organic zinc silicate primer shall be applied (over blast cleaned surface to near white metal conforming to Sa2 ½ finish) on all exterior and interior surfaces.
- ii) Intermediate coat which shall be applied for all interior and exterior surfaces shall consist of epoxy based TiO₂ or MnO₂ of minimum 75 micron DFT.
- iii) Interior surfaces (considered with normally dry condition) shall be finished with (minimum 75 micron DFT) chlorinated rubber paint of approved shade.
- iv) All exterior and interior surfaces (considered as exposed to non-polluted inland atmosphere condition) shall be finished with (minimum 70 micron DFT) epoxy based paint , which shall be further finished with top coat of (minimum 30 micron DFT) polyurethane of approved shade.



- v) All paints shall be of high built constitution.

7.5.5 Basic Requirements for All Civil Works

7.5.5.1 Design requirements

- i) The design of all structures under this contract shall be such that differential and total settlements or other movements shall not exceed acceptable limits and full provision shall be made for all expansion and other joints. The design shall be to the approval of the purchaser.
- ii) Structural members subjected to flexure shall be designed to have adequate stiffness to limit deflections or any deformations that affect strength or serviceability of a structure adversely. The maximum allowable deflections of structural members shall be in accordance with the relevant design standards and/or the limits prescribed by the machinery manufacturers (whichever is less).
- iii) The superstructures and foundations subjected to vibrations (the primary source of these vibrations being the unbalanced forces generated by rotating or reciprocating equipment) shall be designed such that vibrations will be neither intolerable nor troublesome to personnel and will not cause damage to the machine or structure.
- iv) The natural frequency of the whole of the superstructures and foundations or parts thereof and all structures adjacent thereto shall not coincide with the operating frequency of the vibrating plant.
- v) The differences between frequencies and the dynamic analysis of the superstructures and foundations shall be in accordance with the relevant design standard.
- vi) The dimensions of all the buildings shall be such as to provide adequate space for the safe installation and proper operation, maintenance and repair of all plant and equipment.
- vii) Throughout the works all floor slabs above rooms containing electrical equipment shall be watertight. No drain pipes or water pipes are permitted to pass through these rooms.
- viii) All materials used in the works shall be of the best quality of their respective kinds as specified herein, obtained from sources and suppliers approved by the Purchaser or his representative and shall comply strictly with the tests prescribed hereinafter or, where tests are not laid down in this specification, with the requirements of the latest issue of the relevant Indian, American, British, German standards or other standards approved by the purchaser.
- ix) Samples of all materials proposed to be used in the works may be called for at any time by the purchaser.



- x) The work shall be carried out by competent personnel skilled in their various trades.
- xi) Before commencing the works, the contractor shall ascertain the locations and nature of all existing underground services and shall take every possible precaution against any damage occurring to them or interference therewith, during the execution of the works.
- xii) Suitable access to the roofs of the buildings by means of steel stairs shall be provided for maintenance and repair of any installation.
- xiii) All rooms with fire hazard shall be provided with suitable emergency exits.
- xiv) Proper access roads with footpaths shall be provided to bring in all the equipment and to take it out in case of maintenance. These access roads shall be suitable for the vehicles which will be used (cars, forklifts, trucks, trailers etc.) to reach up to the point of unloading of the equipment.
- xv) Safe, convenient and straight forward accesses and means are to be provided to take equipment in and out of all rooms, at all levels using suitable stair wells and suitable electric hoists.
- xvi) Before starting of design works, the contractor shall submit to the purchaser for approval the project design manual containing the design data and the detailed design criteria for all civil works. Design works shall commence only after approval of the project design manual by the purchaser.
- xvii) Final considerations

Before starting of design works, the contractor shall submit to the Purchaser for approval the project design manual containing the design data and the detailed design criteria for all civil works. Design works shall commence only after approval of the project design manual by the purchaser.

xviii) Settlement measurements

- a) Leveling bolts shall be installed by the contractor immediately after construction of foundation slabs and shall be protected by a suitable cover from damage. For the leveling bolts, the requirements of IS: 8009 shall be met.
- b) In all buildings and major foundations at least one leveling bolt shall be installed at 1.00 m above floor surface; for important parts of buildings however, a minimum of 4 leveling bolts shall be provided, depending upon the importance of the installations.
- c) The position and thus the total number of surveying points shall be decided by the purchaser in co-operation with the contractor, on the basis of the settlement report.



- d) The civil engineering contractor shall mark the position of all settlement bolts on his shuttering drawings and shall ensure that these surveying points are not built in as construction proceeds.
- e) In order to keep the number of points which are to be leveled to a minimum, settlement bolts shall be installed on a specific grid. For all measurements, the requirements of IS: 8009 are to be met.
- f) Measurements of all leveling bolts are to be executed:-
- Immediately after setting of the bolt
 - Prior to the erection of mechanical equipment
 - Several times during the erection period of the mechanical equipment
 - After completion of the buildings, structures and erection of all equipment once before the plant is handed over to the Purchaser.

xix) Permissible tolerances

The dimensions of concrete as cast when compared with those on the drawings shall be within the tolerances given below in mm.

a) Cast-in-situ concrete works

<u>Description of item/structural element</u>	<u>Permissible deviation in mm (max)</u>	
Faces of concrete in foundations and structural members against which backfill is placed	+ 25	- 10
Location of footing (for RCC framed structures only)	+ 25	- 25
Eccentricity of footing	2% of footing width in direction of misplacement but limiting to 50mm	
Top surfaces of slabs and of concrete to receive base plates shall be grouted	+ 5	- 5



Alignment of beams, lintels, columns, walls, slabs, and similar structural elements	+ 5	- 5
Cross sectional dimensions of walls, slabs and similar structural elements	+ 5	- 5
Deviation from specified dimensions of cross-section of columns and beams	+ 12	- 6
Alignment of holding down bolts without sleeves	+ 1.5	- 1.5
Alignment of holding down bolts with sleeves	+ 5	- 5
Level of holding down bolt assemblies	+ 10	- 10
Embedded parts (in any direction)	+ 5	- 5
Centres of pockets or holes with greatest lateral dimension not exceeding 150mm	+ 10	- 10
Variation in steps:		
Riser	+ 1.5	-1.5
Tread	+ 3.0	-3.0
Plumb	3 mm for every metre subject to a maximum of 10 mm	
b) Form work		
Levels and heights	± 6 mm	
Plumb	3mm for every metre subject to a maximum of 10 mm	



Unevenness of any surfaces	± 3 mm
Length or breadth	± 12 mm
Diagonals	± 15 mm

In case of inclined surfaces like folded plates etc, the deviation in the alignment of inclined surfaces, shall not exceed 3 mm with reference to the theoretical alignment, for a length of 1000 mm measured vertically, subject to a maximum of 10 mm.

c) Masonry

All masonry shall be built true and plumb within the tolerances prescribed as below. Care shall be taken to keep the perpends properly aligned.

- Deviation in verticality in total height of any wall of a building more than one storey in height shall not exceed +/-12.5mm.
- Deviation from vertical within a storey shall not exceed +/- 6mm per 3m height.
- Deviation from the position shown on the plan of any brickwork more than one storey in height shall not exceed 12.5mm.
- Relative displacement between load bearing walls in adjacent storeys intended to be in vertical alignment shall not exceed 6mm.
- Deviation of bed joint from horizontal in any length upto 12m shall not exceed 6mm, and in any length over 12m it shall not exceed 12.5mm total.
- Deviation from the specified thickness of bed-joints, cross joints or perpends shall not exceed +/-3 mm.

d) Plastering work

The finished plastered surface shall not show any deviation more than 4 mm when checked with a straight edge of 2 metre length placed against the surface.

The thickness of the plaster shall be measured exclusive of the thickness of key i.e. grooves or open joints in brickwork. The average thickness of plaster shall not be less than the specified thickness. The minimum

thickness over any portion of the surface shall not be less than the specified thickness by more than 3 mm for plaster thickness above 12mm and 1 mm for ceiling plaster. Extra thickness required in dubbing behind rounding of the corner at junctions of wall or in plastering of masonry cornices etc. shall be ignored.

e) Pre-cast concrete work

- Length: +/-0.1 percent subject to minimum of - 5 mm and maximum of + 10 mm.
- Cross-sectional dimensions: +/- 3 mm or +/-0.1 per cent whichever is greater.
- Straightness of bow: 1/750 of the length subject to minimum of -5mm and maximum of + 10mm.
- Squareness: When considering the squareness of the corner, the length of the two adjacent sides being checked shall be taken as the base line. The shorter side shall not vary in length from the perpendicular by more than 5mm.
- Flatness: The maximum deviation from a 1.5m straight edge placed in any position on a nominal plane surface shall not exceed 5mm.

f) Reinforcement work

<u>Description of item/structural element</u>	<u>Permissible deviation in mm</u> <u>(max)</u>	
Placing of reinforcement:-		
For effective depth 200 mm or less	+ 10	- 5
For effective depth more than 200 mm	+ 15	- 10
Cover to reinforcement	-	- 5
Cutting of reinforcement		
When minimum length specified	+ 75	-
When maximum length specified	+75	-50

	When maximum or minimum length not specified	+ 75	-25
g)	Tolerance in erected CW liners/pipes, if applicable		
	At setting out points	25 mm in position and level	
	Between setting out point	50 mm in position and level	
	Flanges for condenser	6 mm in position and level connections and the plane of the flanges shall be within 3 mm of the required plane measured across any diameter.	
	Other terminal points	6 mm in position and level and the plane of the flange shall be within 0.3% of the diameter or 1mm whichever is greater, of the required plane measured across any diameter.	
h)	Structural steel work		
	Tolerances on dimensions for fabrication of steel structures shall be according to IS: 7215.		
	Tolerances on dimensions for erection of steel structures shall be according to IS: 12843.		
	Tests on welds shall be as per ASTM standards/ IS: 816 and IS: 9595.		
	Dimensional and weight tolerance of rolled steel shapes shall be as per IS: 1852.		
	Maximum deviation of finished pile from vertical 1 in 75 and other tolerance shall be as per IS: 2911, (part 1).		

7.5.5.2 Basic requirements during construction

- i) Basic cleaning
 - a) Basic cleaning includes all floors, walls, ceilings, built-in fittings and equipment, including the furnishings. The basic cleaning operation must result in a degree of cleanness which permits the fully equipped buildings

and rooms and associated outdoor installations and secured surfaces to be taken over without complaint.

- b) Advertising boards and stickers, temporary protective coatings and claddings, remains and splashes of paint must be removed with water or suitable solvents. Dust and other dirt must be completely removed from all wall and floor surfaces, as well as from all furniture.
- c) Windows and mirrors must be cleaned so that they are completely clear and without streaks.
- d) Perlator gauges, shower heads, odour traps and floor drains of the sanitary installations must be cleaned and the fittings and bright pipe work must be spotlessly polished.
- e) Petrol and oil separators must be emptied, cleaned and refilled if necessary during basic cleaning.
- f) Lamps, including dishes, lighting units and tubes, switches and sockets as well as bases and skirting boards, doors with frames and glazing, windows, window seats and other furniture and fittings must be included in the basic cleaning operation.

ii) Initial equipment

The specification is drawn up on the assumption that the scope of the initial equipment and consumption materials is to be provided complete in every respect; everything required for the use and care of the installations must be supplied, even if this is not expressly specified in the documentation.

- iii) Contractor shall ensure that during excavation ground water level shall be lowered by at least 0.50 m below the founding level adopting appropriate method of dewatering. Lean concrete below foundation shall be laid soon after excavation with minimum loss of time.

7.5.6 Earthwork and Rockwork

7.5.6.1 General

- i) This section applies to all earth and rockwork required for the construction of buildings, any types of structure and burying service lines in the ground.
- ii) The contractor shall satisfy himself as to the ground conditions on the site including the nature of the strata to be excavated, obstructions, possibilities of flooding and such like and shall allow for all provisions necessary to carry out the work in the most suitable manner when submitting his tender.
- iii) Generally, all buildings and structures must be founded on bearing strata which means that all excavation work for foundations shall meet the requirements of

structural analysis based on the results obtained from the soil investigation and of the available information and instruction given in writing by the purchaser.

- iv) Furthermore, this division applies to excavation works in connection with pavement, roadwork and landscaping as far as earth and rockwork is concerned and deals with the handling and disposal of the materials to be re-used or taken to soil dumps on or off site.
- v) Excavation shall be done to the required dimensions and shall be finished according to the specified lines and slopes, in a way acceptable to the purchaser. All necessary precautions shall be taken to cause the minimum possible alteration or disturbance to the material lying under and adjacent to the excavation final lines.

7.5.6.2 Fill materials

The fill materials used and source are to be examined and approved. Excavation materials can be used if they fulfill the requirements.

i) Select fill

Select fill shall have the following properties:

- a) Well graded (uniformity index not less than 5), non-cohesive and nearly silt free (silt content not greater than 5%; up to 10% tolerated, except below footings of structures), salt free (content less than 3%), soils free of organic matter (limit 2%). Decomposing or compressible materials shall not be used.
- b) All materials shall be of such nature and character that it can be compacted to the specified densities in a reasonable length of time. It shall be free of highly plastic clays, of all materials subject to decay, decomposition or dissolution, and of cinders or other materials which will corrode piping or other metal.
- c) The intention is to use select fill below plinth, floors, roads, parking areas etc.

ii) Ordinary fill

Ordinary fill shall have the following properties:

- a) Natural inorganic soils: salt content not greater than 5%, organic matter less than 3%. For other properties see under 'Select fill'.
- b) The intention is to use ordinary fill for non-built areas.



iii) Special fill

Special fill material shall be gravel or crushed rock (for other properties see under 'Select fill'). The intention is to use special fill e.g. as sub-base material for tanks and roads.

iv) Rip-rap/ rock fill

Rip-rap must be of a size suitable for the place where it is to be used, as determined by the speed of the current, wave height and depth of water. Rip-rap shall be of deformable and yielding construction, using round stones if the intention is to safeguard the underlying ground against scour. If the rock infill is to be used as a foundation for structural components, the aim should be to secure effective bedding of angular stones under water. The stones must be weather and waterproof.

7.5.6.3 Excavation

The works shall be excavated either by hand or by use of excavating plant and tools acceptable to the purchaser.

Excavation by hand may be required close to existing installations and/or underground services, but subject to special instruction of the purchaser.

The contractor shall carry out all kind of earth and rockwork for the following particular works as defined hereafter (where applicable):-

- Clearing and grubbing
- Excavation of top soil
- Open cut excavation
- Backfilling
- Safety precaution during earthwork
- Mining or underground excavation (if required)
- Grading
- Replacement of material
- Trench excavation for service lines
- Embankments
- Archaeological findings

i) Safety precaution

The contractor shall be responsible for all necessary safety measures.



Proper strutting, sheeting and bracing, including re-arrangement of the installations when necessary, stabilization and protection of slopes, methods of excavation to reduce risks of slides etc shall be to the contractor's debit. The additional moving of soil resulting from such damages will not be paid for.

ii) Over excavation

If somewhere, and for any reason, excavation are executed beyond the established design level, the contractor shall at his own expenses backfill with lean concrete to purchaser's approval, the volume corresponding to over-excavation.

iii) Stockpiles and disposal

- a) Excavated material from the works selected by the purchaser for re-use shall be placed immediately in its final position, if possible, or otherwise may be stockpiled or deposited on site as directed by the purchaser.
- b) The contractor shall not have the right either to additional payment or to claim because of work involved in stockpiling materials, re-use of for carting to the waste disposal areas. Soil unfit for re-use shall be removed to sites approved by the purchaser and shall not be permanently deposited elsewhere. The contractor shall trim and form the edges of spoil to profiles and levels as directed by the purchaser.
- c) The placing of materials within the waste disposal areas shall be made in layers not exceeding 0.50 m in thickness in order to obtain an appreciable degree of compaction by means of transportation equipment and/or if required by appropriate compaction equipment.
- d) All traffic to or from the waste disposal areas shall run over the surface of such areas in order to achieve compaction.

iv) Preparation of foundations

- a) All rock surfaces on which or against which concrete is to be poured shall be carefully cleaned and roughened to the purchaser's satisfaction.
- b) The rock surface shall be free of oil, stagnant or running water, mud, loose rock, residue and impurities or any other improper material. Rock faults, depressions and fractures shall be cleaned to a depth equal to their widths and to sound rock at both sides. Immediately before concrete placing, all rock surfaces shall be thoroughly cleaned by means of air and water jets, wire brushes, sand jets or by any other devices necessary to clean the foundation and keep it free of water, but shall be moistened prior to placing concrete.
- c) All earth surfaces against which concrete is to be poured, shall be clean and free of any detrimental impurities, organic matter or unsuitable material. Immediately after excavation, all such surfaces shall be moistened and

treated as directed by the purchaser and then protected by means of a lean concrete layer, 7.5 cm or PCC thickness as shown in the design drawings, whichever is greater. No concrete is to be poured until formation is inspected and approved by the purchaser.

v) Backfilling

- a) Foundations and structures shall be backfilled as shown on the drawings with approved material compacted in layers not exceeding 150 mm by suitable equipment until optimum stability has been obtained to the satisfaction of the Purchaser. Compacting shall be carried out with special care by means of pneumatic or mechanical rollers or other compactors of a type previously approved by the purchaser.
- b) Density requirements as per standard Proctor Test shall be in accordance with relevant parts of IS: 2720 and all tests shall be made by/on under the supervision of purchaser at contractor's own expenses, at optimum moisture content:-
 - Backfilling of foundations and under grade slabs - 98%
 - Under roadways and parking areas - 95%
 - Embankment - 95%
- c) The thickness of fill layers, number of passes and type of equipment to be used shall be proposed to the purchaser after compaction tests have been made.
- d) Surfaces receiving fill layers shall, if smooth, be previously scarified to obtain a good key between the new fill layer and the subgrade.
- e) Backfilling of foundation work with approved materials shall be carried out only after foundations have been inspected by the purchaser.

vi) Soil replacement

- a) The material to be used for replacement of soil shall not contain soluble or swelling components such as clays, or organic matters. Sand gravel mixtures of favourable grain size distribution shall be used in exchange.
- b) Prior to the commencement of work, three samples shall be taken from the anticipated borrow area and tested in respect of IS: 2720 or Proctor density, optimum moisture content, grain size distribution and content of soluble matters.
- c) These three samples shall cover the approximate variation of materials to be expected within the borrow area.



- d) The fill material shall be placed in horizontal layers of not more than 15 cm in compacted thickness. The fill moisture content shall be controlled and adjusted in order to achieve a maximum of compaction. Fresh water shall be used for watering of soils.
 - e) The fill material shall be compacted by vibratory roller (min. weight 20 T). The minimum required degree of compaction shall be as defined under “Tests and Properties”. One Proctor and three density tests shall be made at every fourth fill layer prior to continuation of filling work. The testing location will be indicated by the purchaser. The contractor shall either provide all required laboratory facilities and staff to perform the tests or he shall co-operate with an experienced soil testing laboratory, subject to the approval of the purchaser.
 - f) The results of the tests shall be made available to the purchaser within 24 hours of the tests. Filling work may be continued in case all tests performed show satisfactory results.
- vii) Existing pipe work (if any):
- a) If any existing pipe works: groins, buried pipes, pipe and cable ducts, wattle-work, fascines and the like interfere with the excavation profiles, irrespective of whether or not such structures are described in this specification, these works shall be replaced with the approval of the purchaser.
 - b) Any stored materials, such as pipes, fittings, accessories of assorted sizes or any other material obstructing the progress of work shall be re-shifted by careful handling, loading, transporting, stacking and protecting. The contractor will be held responsible and liable for damage caused by him. Any such works shall be included in the lump sum.
- viii) Pipe bed preparation
- a) Pipe beds shall be constructed to guarantee the uniform transmission of loads. The bearing section for supported profiles shall cover at least an arc of 90°.
 - b) Pipes shall be bedded in an earth foundation of uniform density and carefully shaped by means of a template supported at the desired grade, to fit the lower part of the pipe exterior.
 - c) Where rock in either ledge or boulder formation is encountered, it shall be removed below grade and replaced with suitable materials in such a manner as to provide a compacted earth cushion having a thickness under the pipe of not less than one quarter of outside pipe diameter with a minimum allowable thickness of 20 cm if not otherwise specified.



- d) Where a firm foundation is not possible at the grade established due to soft, spongy or other unstable soil, all such unstable soil under the pipe and for a width of at least one diameter on each side of the pipe shall be removed and replaced with suitable selected materials as approved by the Purchaser, properly compacted to provide adequate support for the pipe.
- ix) **Blasting**
- a) The contractor shall obtain license from the district authorities for undertaking blasting work as well as for obtaining and storing the explosives as per Explosives Rules 1940, corrected up-to-date.
- b) The contractor shall comply strictly with the regulation as required by the authorities regarding purchase, storage, issuance and use of explosives and transport of same to and from site, and shall be deemed to have included in his tender all costs arising from the use, storage and transport of explosives as well as from supervision of blasting by security forces.
- c) Blasting shall furthermore be strictly and in every case subject to the purchaser's permission.
- d) All blasting shall be carried out by approved experts only and the contractor shall be fully liable for any claims arising from damage or alleged damage, injury to the public etc. due to blasting.
- e) Fuses, detonators or blasting caps shall not be transported or stored together with dynamite or other explosives. The location and design of the storage places, the transportation methods and the precautions that shall be taken to prevent accidents shall be subject to the purchaser's approval, but it is understood that this approval does not exempt the contractor of his responsibility with regard to the handling of dynamite or other explosives.
- f) Drilling and blasting plans shall be submitted well in advance for the Purchaser's approval prior to commencement of any blasting work.
- g) When blasting is carried out, trees, structures etc in exposed position shall be adequately protected from damage.
- h) Drilling and blasting shall be arranged and, where necessary, the rock being blasted shall be protected so as to prevent any scattering of the rock liable to cause injury to the public or damage to dwellings, buildings and other property and the works.
- i) Blasting shall be carried out carefully to avoid the loosening of rock surfaces that are to remain intact, particularly in those cases where concrete is to be placed directly against these rock surfaces.



x) Protection of existing utilities and services

During construction, the contractor shall provide all protection for existing utilities and services as may be required by his construction operations. Permanent protection of certain items shall be as included under other sections or as instructed by the purchaser.

In addition to the requirements as specified, herein the contractor shall comply with the following requirements:-

- a) Use all necessary precautionary and protective measures required to maintain existing utilities, services and appurtenances that must be kept in operation. In particular, the contractor shall take adequate measures to prevent undermining of utilities and services presently in services.
- b) Protect existing or new utilities and services where required by the contractor's operations and/or as directed by the purchaser. The contractor shall be responsible for bracing and supporting utilities and services to prevent settlement, displacement or damage.

xi) Dust control

The contractor shall use all means necessary to control dust on roads, construction areas and borrow pits.

Surfaces shall be regularly watered to prevent dust becoming a nuisance for the public and interfering with the proper execution of the works.

7.5.6.4 Dewatering during construction

i) General

- a) This division applies to the methods and techniques of ground water control. Prior to the decision for the method and technique to be applied, a comprehensive knowledge of the soil and ground water conditions have to be obtained from the results of the soil investigation and/or information given in writing by the purchaser.
- b) All costs for ground water control for keeping the construction pits dry shall be included in the relevant excavation items of the lump sum except otherwise indicated.
- c) The method and technique shall be based on the IS: 3764.
- d) The scope of supply includes the installation of all equipment, plants, pipes, machinery, etc and its removal after completion including operation and maintenance of the equipment during the construction period.

- e) Where necessary, cofferdams, sheet piles, pump sumps, equipment and channels, troughs, inlet gutters, pipes and any other works required for the water control and discharge shall be part of the scope of supply. The dewatering system shall be designed and installed in such a way that alteration and extensions can be made at any time throughout the operating time, if necessary. Reserve units shall be kept ready for service when failure of any of the installed units occurs.
 - f) The contractor has to consider the possibility of a temporary failure of any pump, diesel engine and/or the electric power service and shall install emergency power units with sufficient capacity to feed the necessary power to the installed unit at the moment of failure. The contractor shall submit to the purchaser, the detailed method of the envisaged pumping system for dewatering, the pump capacity and the standby reserve units. The contractor shall adjust the system if required by the purchaser.
 - g) The contractor must ensure that any dewatering works will not cause any interference to his own work and to those of other contractors working elsewhere on site or at structures under construction. Any damage occurring during the above mentioned period shall then be made good by the contractor at his own expense.
 - h) During the foundation works, the excavated areas, foundation levels, and pits are to be kept free of water down to at least 0.50 m below the foundation level.
- ii) Equipment
- All equipment, instruments, machineries, tools, pipelines, etc required for execution of the water control shall be in good repair and shall be kept in good working condition throughout the operation period.
- iii) Execution
- a) Records
- The contractor shall keep records of all data of importance occurring during operation of the water control system. The records shall be submitted to the Purchaser for information and checking every working day. For that purpose, the lowering of the water table shall be controlled by piezometers. The numbers and position of them shall be submitted to the Purchaser's approval. The contractor shall provide and maintain these piezometers at his own expenses during the dewatering works or as long as the Purchaser requires it.
- Pump operations shall not be stopped nor pipes, channels and equipment for dewatering and water control removed or altered in any way, except with the express permission of the purchaser. The purchaser will stipulate the

time of removal. Until then, the pumps and water drainage facilities shall be kept in proper working order without extra payment being granted.

b) Pump sumps and channels

Provision of pump sumps and channels of the dimensions required for each particular case shall include all necessary excavation of any kind of soil above and under water, backfill and consolidation, sheeting, bracing, stiffening, sealing, scaffolding accesses, as well as the disposal of water and all auxiliary works.

Routing of channels or pipes for discharge water shall be such as not to impede or obstruct any of the other works and/or operations.

The same shall be applicable for pump sumps. Prior to the determination of any arrangement of pump sumps, the purchaser's approval shall be obtained.

Routing and location of water discharge lines shall be submitted to the relevant authorities and to the purchaser's approval.

c) Difficulties during dewatering

The contractor shall consider all difficulties and additional work due to the presence of unexpected ground water during subsequent construction work. Where it is possible to keep off or divert such water without special dewatering arrangements or where work can be carried out normally under or in water, such a method may only be applied after approval from purchaser has been obtained.

d) Ready for service condition

The contractor shall maintain ready for service and regularly clean all dewatering equipment and accessories and shall keep all access clear so that they can safely be used without risk of accident. Any recommendations made by the purchaser in this matter shall be carried out immediately.

e) Leakage

Block outs and pipe connections through structures and their closure, proper grouting of joints, etc or repairs in the event of leakage shall be the responsibility of the contractor.

f) Piezometers

The ground water lowering effect is to be checked by piezometers in unfavourable positions (e.g. in the middle of the building pit) before starting the excavation. The piezometers are to be installed at unfavourable positions or in more permeable layers (in stratified sub-soil) below the

bottom of the excavation. They serve to check whether or not the water pressure (head) has been sufficiently reduced in those layers below the bottom of the excavation which are more permeable. Security against hydrostatic uplift is to be demonstrated by calculation.

7.5.6.5 Test and properties

i) General

The control of working and tests operations shall be carried out by the contractor in the presence of the purchaser.

The contractor shall prepare sheets for statistical analysis of the field and laboratory tests, and shall submit the sheets to the Purchaser for approval. Controlling will consist of field and laboratory tests, such as compaction and density tests, grain size distribution and shear tests.

If not otherwise specified under relevant items, the following min. tests have to be carried out:-

- a) One (1) test analyzing the ingredients of the water used for performance of the work.
- b) Three (3) tests for specific gravity of soil as per IS: 2720.
- c) One (1) test for bearing capacity of soil for static load as per IS: 1888-1982.
- d) Three (3) tests for grain size analysis of soils, if “replacement of material” is required as per IS: 2720.
- e) Three (3) tests of density of soil in place of sandcone method for each second layer of “backfilling and/or replacement of material and/or roadwork” are required as per IS: 2720.

All tests shall be recorded in forms acceptable to the purchaser.

Tests shall be performed for each 500 m³ of fill but not less than once per shift.

ii) Testing of select fill

- a) Select fill, as specified herein, shall be provided as follows:-
 - As fill or backfill within the limits of the structure/building and below basement floors as shown on the drawings to bring the subgrade up to the required elevation or for filling or backfilling against foundations walls and around footings.

- As fill beneath grade slabs or basement floors either to bring local low areas to grade or to replace disturbed or unsuitable soil.
 - Place select fill in approx. 15 cm layers (compacted thickness) and compact to 98% of maximum dry density (IS: 2720).
- b) Quality control shall establish all of the following values:-
- Unit dry weight
 - Standard penetration test: 20 blows per 10 cm penetration.
 - Plate load test as per IS: 1888.
- iii) Testing of ordinary fill

Ordinary fill, as specified herein above, is required for all fill and backfill where special fill or select fill have not been specified on the drawings. Place ordinary fill in 15 cm layers (of compacted thickness) and compact to 95% of maximum dry density at optimum moisture content as per standard Proctor density test.

Quality control shall establish all of the following values:-

- Unit dry weight
- Standard penetration test: 16 blows per 10 cm penetration.
- Plate load test as per IS: 1888.

7.5.6.6 Foundations

i) General

- a) This clause describes all foundation works which are to be performed so as to ensure the bearing of all loads without detriment for and damage to the structures. The contractor has to choose up-to-date methods and equipment to ensure this in accordance with relevant internationally recognized standards.
- b) The soil conditions met during the foundation works especially in the foundation level are shall be checked by the contractor's soil engineer, recorded and compared with previous known or investigated results. If essential differences occur, which could be detrimental to the structures, the contractor has to inform the purchaser and to propose further measures. Foundation works in such areas are to be continued only after approval of such measures by the purchaser.



- c) If there is any doubt about the soil quality or if discrepancies appear with regard to the previous decisions or investigations stated by the purchaser, then additional measures are to be taken after consulting the purchaser (e.g. additional excavation and lean concrete fill).
- d) Immediately prior to concreting any footing, the contractor has to verify the specified soil conditions below the foundation level by a sounding.
- e) For soil improvement works i.e. execution of special foundations (except replacement method) only special contractors (or sub-contractors) are acceptable subject to providing proof of experience in successful execution of such works in the form of a detailed description and references. Together with the description and the references a detailed execution programme including quality control measures relating to the actual site conditions is to be transferred to the purchaser for approval.
- f) Detailed geo-technical investigation shall be required to be carried out to ascertain the safe bearing capacity and appropriate type of foundation for heavy equipment and structures.
- g) The geo-technical exploration, testing and analysis information shall be used to determine the most suitable bearing method to support each foundation. The bearing method may include engineered fill, piling, drilled shafts, pressure injected footings or soil densification. Piling required to support foundation shall be provided by bidder.

ii) Bearing capacity

The foundations shall be designed for the following factors of safety:-

Shallow foundations : 3.0

Deep foundation systems : 2.0

Static, dynamic and integrity tests shall be performed by an independent testing analyst.

iii) Settlement criteria

Allowable settlements, elastic plus consolidation, shall be limited as follows:-

Total settlement : 38 mm

Differential settlement : 6 mm

Foundations for equipment shall be designed to meet the total and differential settlement established by the equipment manufacturer if they are more stringent than the allowable settlements listed above. Foundations for buildings shall be designed

to meet the total and differential settlement as required for the building function if they are more stringent than the allowable settlements listed above.

7.5.6.7 Pit wall stability

The excavated pit sides, walls or slopes have to be stable and established with respect to safety regulations:

IS: 1200 (part 1) : Method of measurement of building and engineering work

IS: 3764 : Safety code for excavation work

7.5.6.8 Settlement and expansion joints

- i) Joints are to be arranged in such a way that stresses and strains caused by settlements, temperature, differential settlement, etc do not adversely affect the structures. This primarily applies to differently loaded areas and structures having different foundations or foundations of different depths. The settlement joints shall run through the complete structure down to foundation level, the expansion joints however shall stop on the top level of foundations.
- ii) The joint width which is to be at least 2 cm is to be planned considering all relevant factors (settlements, tilting, movements, aspects etc.).
- iii) Settlements of all relevant structures shall be measured, recorded and shown in diagrams according to IS: 8009 – “Code of practice for calculation of settlement of foundation”.

7.5.6.9 Foundations at different depths

Foundations at different levels should be based beyond a load spread angle of 30° (against the horizontal). Otherwise, the load influence (e.g. earth pressure) of the higher level structures on the lower ones must be taken into consideration.

7.5.6.10 Safety against uplift

For all parts of the structures extending into the ground water, safety against uplift has to be guaranteed during all execution stages, especially when ground water lowering is terminated.

7.5.6.11 Shallow foundations

In this clause shallow foundations are described where the footings rest on the natural bearing soil. For this kind of foundation especially the following standard is to be applied:

IS: 1080 Code of practice for design and construction of shallow foundations on soil

IS: 6403 Code of practice for determination of bearing capacity of shallow foundations

The excavation for the foundations can be done by machines, if the underground is not disturbed by this procedure. In every case, the last 20 cm above the foundation level are to be excavated by hand.

7.5.6.12 Replacement

If unsuitable soils are encountered below the grade slabs or basement floor, they are to be replaced by suitable layer wise compacted material down to the good bearing soil.

Materials and compaction method as well as quality control are described in clause 'Earth and Rockworks' of this section. Select fill shall be employed below all grade paving and basement floors.

7.5.6.13 Special foundation requirements for rotating equipment

- i) The foundation systems for rotating equipment shall be sized and proportioned not to exceed the bearing and settlement criteria and to assure satisfactory performance of the equipment. In addition to a static analysis, a dynamic analysis shall be performed to determine the fundamental frequencies of the foundation system. To preclude resonance, the fundamental frequency of the foundation shall be 25 percent removed from the operational frequency of the equipment. The dynamic behaviour of the foundation shall meet the requirements of IS: 2974 (part I to IV) – Code of practice for design and construction of machine foundations.
- ii) All rotating equipment shall be provided with rigid foundation system except TG which shall be supported on vibration isolation spring system mounted foundations. The vibration isolation system supplied should be of proven make, consisting of steel helical spring units and viscous dampers (providing damping resistance in all three planes). The vibration isolation foundation system shall be provided for turbo-generator only and all other equipments such as boiler feed pumps, ID/FD/PA fans, coal mills etc. shall be supported on rigid foundations.
- iii) If minor equipments are to be supported on building structures, floors etc. suitable vibration isolation shall be provided.

7.5.7 Concrete Works

7.5.7.1 Reinforced concrete structures shall be designed in accordance with the latest Indian standards IS: 456- Building code requirements for reinforced concrete.

Water retaining RCC structures shall be designed in accordance to IS: 3370 part I to IV – Code of practice for concrete structures for storage of liquids.

7.5.7.2 Materials

Quality of materials

The materials described below shall be specified and used as a basis for design.

- i) Reinforcement: Reinforcement shall be high yield strength deformed bars conforming to IS: 1786 (Grade Fe415/ Fe500).
- ii) Cement: Fly ash based Portland Pozzolana cement conforming to IS: 1489 (Part-1) shall be used for all areas other than for the critical structures identified below. However, Purchaser may allow the use of other types of cement namely, ordinary Portland cement and Portland slag cement conforming to IS: 269 and IS: 455 respectively under special circumstances on specific request of the bidder and prior approval of the purchaser. Minimum grade of cement shall be Grade 33. Higher grade of Portland ordinary cement namely Grade 43 and Grade 53 conforming to IS: 8112 and IS: 12269 respectively can also be used for specific application. However the ordinary Portland cement shall necessarily be used for following structures.
 - TG foundation top deck and sub-structure excluding raft.
 - Structures requiring grade of concrete of M30 and above.

In place of fly ash based Portland Pozzolana cement fly ash can be added in ordinary Portland cement (Grade 43). Batching plant shall be deployed for producing the concrete. Fly ash shall conform to IS: 3412. Percentage of fly ash to be mixed in concrete shall be based on trial mix. Sulphate resistant cement, conforming to IS-12330, shall be used in concrete mixes when concrete is exposed to aggressive soil/water conditions.

- iii) Aggregates: Fine aggregates shall be clean natural sand. Coarse aggregates shall be crushed rock. All aggregates shall meet the requirements of IS: 383.
- iv) Admixtures: Plasticizers and retarders shall be used to control setting time and to obtain optimum workability. Interior slabs to be trowel finished shall use less air entrainment. The use of calcium chloride shall not be permitted.
- v) Water: Clean water of potable quality shall be used in all concrete mixes.

7.5.7.3 Storage of materials

All materials shall be stored and handled in a manner that will prevent contamination and/or deterioration. Storage of materials shall conform to IS-4082 "Recommendation on stacking and storage of construction materials and components at site". Deteriorated and/or contaminated material shall not be used for the concrete and shall be removed from the site at the expense of the contractor.



7.5.7.4 Cement

- i) Sampling and testing of cement
 - a) All deliveries of cement to the concrete supplier shall be accompanied by a certified mill test report and shall include all of the physical and chemical properties as required by relevant IS: 12269 for grade 53 cement, IS: 8112 for grade 43 and IS-12330 for sulphate resistant cement.
 - b) The manufacturer's test certificate will normally be accepted as proof of compliance with the specification, but the Purchaser may order further tests of a character specified in the appropriate Indian standards. The confirmatory tests are to be conducted by a recognized quality control organization. The contractor shall bear all expenses required for the preparation, dispatch, and tests of the samples. In case the results of such tests show any sample to be inferior to specifications, the whole consignment from which the sample was taken shall not be used and shall be immediately removed from the site.
- ii) Delivery and storage of cement
 - a) The following information shall be provided for all cement shipments (either whole or part) which are intended for delivery to site: date of manufacture, date of original loading, destinations en-route, date of unloading, intended date of delivery to site.
 - b) Cement which has been manufactured for longer than 6 months on the proposed date of delivery to the site shall be inspected, sampled and tested for approval purposes before delivery to the site.
 - c) The contractor shall obtain and provide to the purchaser the manufacturer's bulk average test certificate for each consignment of cement to the works. The certificates shall be provided before the consignments are required for use and shall show the chemical composition and physical properties determined in accordance with the relevant standard.
 - d) Samples shall be taken from each consignment of cement and tested as directed by the purchaser in an approved independent laboratory.
 - e) When bulk cement deliveries are proposed, the contractor shall provide all information required by the purchaser concerning off-site storage and loading arrangements and shall provide reasonable facilities for the Purchaser to inspect these arrangements for approval purposes.
 - f) Consignments shall be used in the order in which they were delivered.
 - g) All bagged cement shall be stored in a weatherproof building having dense impervious bituminous or concrete floors which shall be kept swept clean at

all times. The storage arrangements shall be fully completed and approved by the purchaser before any cement is delivered to site.

- h) Each consignment of cement shall be separately stored for ease of access, identification, inspection and sampling. Sufficient stocks shall be maintained on site to ensure the proper progress of the works and the stock holdings shall be to the approval of the purchaser.
- i) If bagged cement is stored in silos it shall be charged into the silos through at 6.3 mm mesh screen which is welded or bolted to and covers the entire feed area of the silo charging hopper.
- j) Cement stored in silos shall be adequately protected against rain, humidity and dewfall, and all silo charging and discharging points shall be properly sealed. Silo aeration equipment shall if available, incorporate de-humidifiers.
- k) No cement from any consignment shall be used in permanent works without the approval of the purchaser.
- l) Cement which contains air-set or hardened lumps, re-powdered air-set material, foreign matter or which has been contaminated or is otherwise unsatisfactory in the opinion of the Purchaser will be rejected and shall be removed from site without delay.
- m) The contractor shall be responsible for satisfying himself that the performance characteristics of cement are not such as to necessitate excessive cement content or be likely to cause or accentuate any undesirable properties in the fresh or hardened concrete notwithstanding apparent compliance with this specification.
- n) Bulk cement shall be used for structures, bagged cement shall be used for masonry, plaster etc.

7.5.7.5 Water

Water used for mixing and curing shall be clean and free from injurious amounts of oils, acids, alkalis, salts, sugar, organic materials or other substances that may be deleterious to concrete or steel.

The pH value of water shall not be less than 6.

Non potable water may be used for the production of concrete and processing of aggregate provided the following requirements are satisfied:-

- i) The compressive strength of 150 mm cubes made and tested in accordance with IS: 456 using the proposed water shall not be less than 90% of the average of strength of three similar concrete cubes prepared with distilled water.

- ii) The initial setting time of test block made and tested in accordance with IS: 4031 and containing the proposed water shall not be less than 30 min. and shall not differ by ± 30 min. from the initial setting time of control test block made with distilled water.
- iii) The following chemical limits shall not be exceeded:
 - a) Chlorides (CL) < 2000 ppm
 - b) Sulphates (SO₄) < 400 ppm
 - c) Organic < 200 ppm
 - d) Inorganic < 3000 ppm
 - e) Suspended solids < 2000 ppm

The concrete supplier shall provide chemical and physical test data for each source of water to be used prior to use.

When water is transported in tank trucks, each unit shall be accompanied by a chemical test report indicating compliance with the above requirements.

All water to be analysed by an independent laboratory before any work commences and at intervals as direct by the Purchaser tests and quality of water shall be in accordance with IS: 456 or equivalent.

7.5.7.6 Aggregates

The aggregates for concrete shall be crushed natural rock subject to purchaser's approval.

The aggregate to be used in the work shall be supplied from an established pit or quarry. The aggregate source shall have a minimum five (5) years history of satisfactory performance in structural concrete and consistency of supply.

The concrete supplier shall obtain from the aggregate producer, or otherwise provide current test, examination, inspection reports performed and certified by an approved laboratory for submittal to the purchaser.

As a minimum, this information shall include the following items:-

- i) A comprehensive description, with current photographs of the pit or quarry, including but not limited to, identification by name and location, type of deposit, age, potential reserves, primary products by size including average gradation based on previous six (6) months production and the range for each sieve size; mining methods, process equipment, quality control organization and laboratory; the primary and alternate means of product transportation; listing of primary and secondary users of the product.
- ii) Petrographic examination in accordance with IS: 2386 (Part-8) performed by a qualified concrete aggregate petrographer. This report shall be based on material produced and examined within the previous six (6) months and must be representative of the current production.

- iii) Coarse aggregate shall be sampled from current production in accordance with IS:2386 (part 1 to 8). Three [20 mm, 10 mm and 5 mm] nominal maximum size (NMS) aggregates shall be sampled and tested as follows:-

IS: 2386(part 1): Methods of test for aggregates for cement- Particle size and shape (Amendment 3)

IS 2386(part 2): Methods of test for aggregates for concrete- Estimation of deleterious materials and organic impurities (Amendment 1)

IS 2386(part 3): Methods of test for aggregates for concrete:- Specific gravity, density, voids, absorption and bulking

IS 2386(part 4): Methods of test for aggregates for concrete- Mechanical properties (Amendment 3)

IS 2386(part 5): Methods of test for aggregates for concrete- Soundness

IS 2386(part 6): Methods of test for aggregates for concrete- Measuring mortar making properties of fine aggregates (Amendment 2)

IS 2386(part 7): Methods of test for aggregates for concrete- Alkali aggregate reactivity

IS 2386(part 8): Methods of test for aggregates for concrete- Petrographic examination

Aggregates when subjected to the tests defined in items above, unless otherwise approved by the purchaser shall meet the requirements of IS: 383 and IS: 456.

Testing is to be carried out at the following intervals:

Type	Coarse Aggregates	Fine Aggregates
Grading	Daily	Daily
Specific gravity	7 days	7 days
Magnesium sulphate soundness	30 days	-
Clay, silt and dust content	Daily	Daily
Shape (elongation and flakiness)	3.5 days	-
Los Angeles abrasion	Initial stage only	Initial stage only
Moisture content	2 days	2 days
Drying shrinkage	Initial only	Initial only



Type	Coarse Aggregates	Fine Aggregates
Organic impurities	30 days	30 days
10% fines value for concrete	7 days	-

Combined grading also on a daily basis.

iv) Storage and handling of aggregates

- a) Cement and densified silica fume shall be stored in separate weather-tight buildings, bins or silos that will exclude moisture and contaminants. At least two cement silos are required with enough storage for a total of 400 metric tonnes of cements.
- b) Aggregate stockpiles shall be arranged and used in a manner to avoid segregation and to prevent contamination with other materials or with other sizes of like aggregates. Aggregate delivery trucks shall be covered to prevent wind blown contamination. Aggregate stockpiles shall be located relative to prevailing winds to mitigate the accumulation of wind-borne dust.
- c) Adequate storage shall be provided for each aggregate. The aggregate storage area shall be on concrete pavement sloped to drain excessive moisture. The aggregate storage area shall provide bulkheads to separate piles and protect against wind blown contaminants. Provision shall be made to shade and sprinkle the aggregates with potable water.
- d) Aggregate stockpiles shall be built in successive horizontal layers not exceeding 1 m in thickness, with each layer being completed before the next is started. No vehicles shall be allowed to operate on top of the stockpiles.
- e) Re-screening and washing of coarse aggregates is required, if necessary, to reduce total chloride and/or sulphate contents to a level less than the maximum allowed by the specifications. If re-screening is required, the screening and washing shall be just prior to transferring aggregate to batch plant bins. Aggregates shall be dewatered over a screen to remove excess water before being stored in the batch plant bins.
- f) Natural or manufactured sand shall be allowed to drain until it has reached somewhat uniform moisture content before it is used.
- g) Liquid admixtures shall be stored in such a manner to avoid contamination, evaporation and segregation in accordance with the manufacturers' recommendations.

- v) Fine aggregate
- a) Fine aggregate source shall be manufactured crushed stone or rock sand, excluding fines which are by products/rejects of coarse aggregate production. The crushed stone sand shall be graded from fine to coarse with the coarse sizes predominating to give maximum density.
 - b) The amount of fine particles as ascertained by the laboratory sedimentation method shall not exceed 10% for crushed stone or 4% for natural sand.
 - c) The amount of material passing a 75 micron sieve (IS test sieve) shall not exceed the following limits:-

Crushed stone sand
 - Concrete subject to abrasion 1% by weight
 - All other concrete 3% by weight
 - d) There shall be no clay or fine silt present.
 - e) The amount of hollow shells like to form voids or remain partially unfilled and present in material retained on a IS 2.36 mm sieve, determined by direct visual separation, shall not exceed 3% by weight of the entire sample.
 - f) Fine aggregate shall not contain appreciable amounts of flaky and/or elongated particles.
 - g) The water absorption of fine aggregate, determined in accordance with BS 812 shall not exceed 2.0% by weight.
 - h) Fine aggregate subjected to five cycles of the soundness test, specified in IS: 2386 (part-5), shall not show a loss exceeding 10% when sodium sulphate solution is used and 15% when magnesium sulphate solution is used, except where approved otherwise.
 - i) Tests are to be executed in accordance with IS: 2386. The grading of fine aggregate for concrete work shall comply with the requirements of IS: 383.
 - j) The grading of the aggregates should be such as to produce a concrete of the specified proportions which will work readily into position without segregation and without the use of an excessive water content. The grading should be controlled throughout the work so that it conforms closely to that used for the preliminary tests.
 - k) A check on the moisture content of sand should be made at least once a day before concreting. The amount of water to be added to the concrete mix should be adjusted accordingly. Any washing, screening, classifying and other operations on the fine aggregate required to meet this specification

shall be done by the contractor. Washing is required if the content of salt adhering to the aggregate is found to be unacceptably high.

vi) Coarse aggregate

- a) Coarse aggregate shall be crushed rock and shall be free from decomposed stone, clay, earth or other deleterious substances. The specific gravity of the coarse aggregate shall not be less than 2.5 t/m³. Aggregate of crushed natural stone is deemed adequate if the stone reveals a crushing strength of 1000 kg/cm² when tested. Friable, flaky and laminated pieces, mica and shale shall only be present in such quantities as not to affect the strength and durability of the concrete.
- b) The grading of coarse aggregate for concrete shall comply with the requirements of IS: 383.
- c) Samples of aggregates shall be submitted to the purchaser, together with sieve analysis showing the proportion by weight passing sieves. When aggregates which are satisfactory to the purchaser have been selected, the contractor shall secure his entire supply of each material from the same source so as to maintain the same quality and grading throughout the work. Should it become necessary to change the source or characteristics of the material supplied this shall only be done after additional tests.

7.5.7.7 Concrete additives

i) Use of concrete additives

Concrete additives approved by the purchaser shall be used to improve consistency, workability, quality and strength of the concrete.

Chemical admixtures manufacturer shall provide certified test reports from qualified independent laboratories showing actual test results indicating material that complies in all respects with the applicable specification.

Admixtures used in concrete shall conform to the appropriate specification and requirements as indicated below:-

- a) Air entraining admixtures shall conform to IS: 9103.
- b) Water reducing and retarding admixtures shall conform to IS: 9103. Accelerating admixtures shall not be used.

High range water reducers shall be naphthalene-sulfonated polymer based material. No admixtures containing chlorides shall be used.

- c) Chemical admixture suppliers shall provide certified test reports with each shipment indicating compliance with the appropriate specification. The test

reports shall include the chloride content of the admixture, specific gravity and solids content.

- d) Fibers: Polypropylene fibers shall be collated, fibrillated polypropylene fiber of approved manufacture.
- e) Corrosion inhibitors: Reinforced concrete subject to contact with seawater and brine, as a result of submergence, splashing, spray, leakage from piping or plant, or from any other cause, shall have a proprietary concrete corrosion inhibiting compound incorporated into a concrete mix.

The corrosion inhibitor shall be appropriate to the protection of steel reinforcement against corrosion throughout the 25 year design life of the structures. The corrosion inhibitor shall be compatible with the required concrete mix and shall be appropriate to the environmental exposure. Before incorporating corrosion inhibitor into any concrete mix, the contractor shall submit details for review and written consent by the Purchaser.

The corrosion inhibitor shall be equivalent bipolar concrete penetrating corrosion inhibitor (CPCI) and inert epoxy phenolic coating system. The dosage of which shall be as per manufacturer's instructions.

- f) Admixtures used in production of concrete shall be the same as used in establishing the required concrete mix and shall be used in accordance with the manufacturer's directions.
- ii) Accelerating and retarding additives

Such additives shall only be used in case of necessity and after obtaining the written approval of the Purchaser.

- iii) Plasticizers and air entraining additives

Plasticizers and air entrainers are intended to reduce bleeding of free water at the surface. It shall only be used after the written approval of the purchaser and in accordance with the manufacturer's instructions.

7.5.7.8 Concrete mixes

- i) General description and proportions and mixing

The mix proportions are to be determined by proper mix design based on the requirements for strength, workability and the particular site in which the concrete is to be placed. The mix design shall be carried out by the contractor's concrete purchaser. The design of mixes shall be based on the principles of IS: 456-2000.

S. N.	Class	Grade of concrete	Minimum cement content (kgs/cum)	Maximum free water content
a)	Plain concrete used for lean concrete, screeds and backfill	M15	260	0.6
b)	Reinforcement concrete For structural work in foundation and superstructure	M25	365	0.5
	Reinforced concrete for water retaining structure	M25	-	-
c)	TG foundation deck	M40	425	0.4
d)	TG foundation substructure	M30	400	0.45
e)	Mill foundation and fan foundations	M30	400	0.45
f)	Pre-cast concrete	M25	365	0.5
g)	Pavement around buildings	M20	325	0.55

Concrete aggregates and cement shall be proportioned and batched by weight. Water and liquid additives shall be proportioned. If the contractor wishes to use cement in bulk, his method of obtaining the correct proportions of cement shall be approved by the purchaser before use.

ii) Trial mixes

- a) Before concreting commences, the contractor shall, at his own expense, make trial mixes to determine the mix proportions required to produce the strengths specified for each class of concrete and for each degree of workability required to allow placing, transporting and compacting of the concrete with the equipment he proposes to use in any particular situation. Only materials which the contractor intends to use for concreting (including all admixtures) shall be used in the trial mixes.
- b) Test cubes from trial mixes shall be made and tested in accordance with IS: 516.
- c) As per IS: 456 and IS: 516, three separate batches of concrete should be made, workability of each batch determined and three test cubes shall be made from each batch for each age (e.g. for 7 and 28 days) at which tests are required. The strength shall conform to target mean strength as per IS: 456 – Requirements for design mixes.

- d) The appropriate strength requirements may be considered to be satisfied if none of the strengths of the cubes is below the required characteristic strength and if the average strength of the nine cubes is not less than recommended by IS: 456 and IS: 516, trial mixes.

iii) Quality and testing

Not more than 5% of the test results may fall below the 28 days specified strength. Making and curing of test specimens shall be in accordance with relevant IS: 456, IS: 516 and IS: 1199.

All mixes can only be placed following approval by the purchaser. The mean strength shall exceed the characteristic strength by a margin of 1.65 times the standard deviation expected from the batching plant. However, no standard deviation less than 3.5 N/mm² shall be used as a basis for designing a mix.

iv) Trial mixes and field tests

Sufficient laboratory trial mixes shall be affected to show that concrete complies fully with the specified performance criteria. The following tests are to be included:-

- a) Air content < 1%
- b) Slump: Piles 170 ± 25 mm, regular work 80 ± 20 mm as per IS: 1199
- c) Fresh and hardened concrete densities
- d) Field trial mixes shall be carried out under full-scale site conditions as per IS: 4925 (for structural concrete only).
- e) Where directed by the purchaser, concrete incorporating reinforcement details shall be cored to assess stratification of mixes. Cores of 150 x 200 mm (diameter and length) shall be used.
- f) Each trial mix shall have 9 x (150 x 150 mm) cubes taken to measure 24 hours/7 days and 28 day compressive strengths. These trials shall be run for three consecutive days (for structural concrete only).
- g) At least 3 x sets of field trials shall be tested according to the provisions laid down in laboratory testing.
- h) The average 28 day characteristic strength for trial mixes shall be higher by 10 N/mm² than that for cubes taken in the field. Failure to comply shall result in the mix having to be re-designed.
- i) All test results shall have to be complied before approval can be given.

v) Consistency of concrete

The amount of water used in the concrete shall be adjusted as required to ensure such a consistency that it can be readily transported, placed and compacted without segregation of the materials or bleeding of free water at the surface. Addition of water to compensate for stiffening of the concrete before placing shall not be permitted. Consistency of the concrete shall be checked by slump tests measured in accordance with IS: 1199 and shall not exceed the values given in clause 7.1 of IS: 456-2000.

vi) Mixing of concrete

- a) The cement and aggregate shall be thoroughly mixed in a batch-type pull mill mixer. The capacity of the mixer shall not be less than 1 (one) cubic metre and the total capacity of the batching mixing plant shall be such to accommodate the various concrete quantities to be cast in a continuous way and shall comply with the requirements of IS: 456, IS: 1791 and IS: 12119.
- b) The water shall not be added until all the aggregate and cement are in the drum. Mixing shall continue until the concrete is uniform in colour and for not less than 2 (two) minutes after all the materials and water are in the drum.
- c) Partly set or excessively wet concrete shall not be used. No concrete shall be mixed by hand.

vii) Laboratory

The contractor shall establish and maintain a field laboratory on the site and this laboratory shall be available at all time to the purchaser.

The laboratory must have qualified technicians to carry out all tests and must be adequately equipped to ensure that all necessary testing work can be carried out in compliance with the standards.

7.5.7.9 Strength of concrete

i) Testing of fresh concrete by means of test cubes

- a) All test cubes shall be made and tested for compressive strength in accordance with IS: 456, IS: 516 and IS: 1199.
- b) The minimum required strength for different classes of concrete shall be as shown in clause “General description and proportions and mixing” here-above.
- c) The grade of concrete required will depend partly on the particular use and the characteristic strength needed to provide the structure with adequate ultimate strength and partly on the exposure conditions and the cover provided to any reinforcement.

- d) A minimum of four test samples (of six test cubes each) shall be taken on each concreting day (from the same mix) and for at least each 40 m³ of concrete mixed. At least one sample shall be taken for each shift.
- e) For columns, beams and cantilevers seven (7) cubes for every 15 m³ of concrete poured shall be taken. The concrete for test samples shall be taken directly from the concrete mixer and shall be handled (vibrated etc) under similar conditions to those prevailing during the construction. The moulds for the test cubes shall be made of steel. Tests shall be carried out in an approved laboratory.
- f) The strength level of each type and each strength concrete will be evaluated separately and the concrete strength will be considered satisfactory if:
- Compressive strength: The concrete shall be deemed to comply with the strength requirements when both the following conditions are met:-
 - The mean strength determined from any group of four consecutive test results complies with the appropriate limits in column 2 of table 11 of IS: 456.
 - Any individual test result complies with the appropriate limits in column 3 of table 11 of IS: 456.
 - Flexural strength: When both the following conditions are met, the concrete complies with the specified flexural strength:-
 - The mean strength determined from any group of four consecutive test results exceeds the specified characteristic strength by at least 0.3 N/mm².
 - The strength determined from any test result is not less than the specified characteristic strength less 0.3 N/mm².
- g) If the results are less than those specified, the Purchaser must suspend all concreting work and order further tests. Any concrete found not to comply with the specification shall be broken out and replaced to the satisfaction of the purchaser.
- h) The contractor shall pay all costs incurred in making, curing, delivering and testing of concrete cubes.
- ii) Testing of concrete in structures
- a) The types of tests described hereinafter are applicable to the finished parts of the structures. They may be used in routine inspection and for quality control.

- b) Type of tests:
- Cutting cores: The procedure used shall comply with the requirements of IS: 516 or an approved equivalent standard.
 - Gamma radiography: The testing shall be carried out in accordance with the requirement of IS: 13311, part 1 or equivalent.
 - Ultrasonic test: Such tests may be used to obtain approximate indications of the strength of the concrete in the structures (IS: 13311, part 1).
 - Electromagnetic cover measuring devices: Such tests may be used to verify the position of the reinforcement and shall be in accordance with the requirements of design (IS: 13311, part 1).
 - Rebound hammer test: Such tests may be used to obtain approximate indications of the strength of the concrete (Ref. IS: 13311, part 2).
 - Load tests of structures or parts of structures: If the results of the above mentioned check tests show that the quality of the materials is inadequate or if other defects are revealed, the purchaser may require a loading test to be made.
- c) For the purpose of testing floors, roofs and similar structures and their supports, the test load shall be equivalent to the sum of the characteristic dead load and one-and-a quarter times (1.25 times) the characteristic imposed load for a period of 24 hours which the works or part thereof to be tested have been designed.
- d) Wherever certain procedures for testing of parts in structures (e.g. piles) are required by standards or codes of practice, these are to be followed. All tests must be conducted in the presence of the purchaser.
- e) If within 24 hours of removal of the imposed load, the structure does not recover at least 75% of the deflection under superimposed load, the test may be repeated after a lapse of 72 hours. If the recovery is less than 80%, the structure shall be deemed to be unacceptable.
- f) If the result of the test is not satisfactory, the purchaser shall instruct that the part of the works concerned be taken down or cut and reconstructed to comply with this specification. The contractor shall at his own cost take down or cut out and reconstruct the defective work.
- g) The purchaser may require other tests to be made. Number of samples, tests and types will be as per Purchaser requirements.
- h) All the costs for the above mentioned tests shall be borne by the contractor.

7.5.7.10 Transport of concrete

- i) Immediately after mixing, the concrete shall be conveyed to the place of use as rapidly as possible using methods which will prevent the segregation, loss or contamination of materials. The concrete shall be placed and compacted within 90 minutes of the addition of water to the mix. Any concrete left unplaced after this time shall be rejected and removed from the site.
- ii) The concrete shall be transported in dumpers or trucks. Before using concrete pumps, placer pipelines, chutes or spouts it is necessary to have the written approval of the Purchaser.
- iii) The contractor shall obtain permission at least 24 hours in advance of any concrete pour.

7.5.7.11 Concreting operations

- i) Inspection prior to concreting

All concreting methods shall be subject to the approval of the purchaser.

Concrete placing shall not be started until the purchaser has approved all preparation of forms, reinforcement, joints and all mixing, conveying, spreading, curing, finishing and protection equipment.

- ii) Placing of concrete
 - a) Concrete shall be placed in the forms as close as possible to its final position in a single operation to the full thickness of slabs and beams and shall be placed in horizontal layers, not exceeding 2.5 m height in a single pour in walls, columns and similar members.
 - b) The contractor shall organize the pouring of concrete in such a manner that once concreting of a section has started the operation shall be continuous and each operation shall be completed prior to a stoppage.
 - c) The temperature of concrete shall not exceed 40°C measured at discharge into the works.
 - d) The maximum allowable temperature of any point within any cast element is 60°C. The maximum allowable temperature differential between any two points in the same element is 15°C. Additional temperature control measures during construction (such as the use of insulated formwork) will be required. Contractor to prepare a process control chart and method statement verifying measures to achieve these requirements.



- e) Temperature monitoring of concrete work is required where:
- The minimum dimension of any casting is 0.8 m or more, or
 - Where otherwise instructed by the purchaser.
- f) Where specified on the drawings, construction, expansion or contraction joints shall be provided and the concrete shall be poured continuously between two adjacent joints. No other joints than shown on the drawings shall be permitted. Stoppage (cold) joints formed between two concreting operations separated by more than 6 hours time shall be subject to the same treatment as the construction joints.
- g) Concrete shall not be dropped into place from a height exceeding 1.5 m. Trunking and chutes to purchaser's approval shall be used for any concrete to be deposited from a height exceeding 1.5 m.
- h) Concrete which has partially hardened shall not be exposed to injurious vibration or shock, except for controlled re-vibration where specified. When concreting of a certain large structural element is specified strictly as to be poured continuously, then the concreting operations shall be organized for day and night working, in long shifts, as necessary.
- iii) **Compaction and mechanical vibration of concrete**
- As concrete is being placed it shall be compacted by mechanical vibrators complying with IS: 2505, IS: 2506, IS: 2514 and IS: 4656, to obtain a dense material free from honeycombing, free from water and air holes.
- The contractor shall ensure that the vibrators are used in such a manner that the reinforcement is not displaced, the formwork not damaged and no segregation caused, but complete compaction of the concrete is achieved.
- iv) **Finish of concrete**
- The concrete face shall have the finishes indicated on the drawings or in the present specification. The finished surface of the concrete shall be sound, solid and free from honeycombing, protuberances, air holes or exposed aggregate. No plastering, cement wash, mortar or paint shall be applied to cover defective concrete surfaces.
- v) **Construction, expansion and contraction joints**
- a) Construction joints
- The number of construction joints should be kept as low as possible consistent with reasonable precautions against shrinkage. Concreting should be carried out continuously up to construction joints.

- Where it is necessary to introduce construction joints, careful consideration should be given to their exact location, which should be indicated on the drawings. Alternatively, the location of joints should be subject to agreement between the Purchaser and the Contractor before any work commences. Construction joints should be at right angles to the general direction of the member and should take due account of shear and other stresses.
- Concrete should not be allowed to run to a feather edge and vertical joints should be formed against a stop board.
- The top surface of a layer of concrete should be level and reasonably flat unless design considerations make this undesirable. Joint lines should be so arranged that they coincide with features of the finished work.
- If a kicker (i.e. a starter stub) is used it should be at least 70 mm high and carefully constructed. The kicker must be incorporated with the previous concrete. Where possible, the formwork should be designed to facilitate the preparation of the joint surface, as the optimum time for treatment is usually two to four hours after placing.
- The maximum horizontal length of wall to be poured in one operation in any one direction is 7.5 m. A period of 7 days to be allowed between adjacent pours except where water stops are provided when this can be reduced with purchaser's approval. Alternatively a gap of 600 mm wide shall be left between adjacent pours and filled after 7 days from the date of formation subject to purchaser's approval.
- Immediately prior to recommencement of concreting on a joint, the surface of the concrete against which new concrete will be cast should be free from laitance and should be roughened to the extent that the largest aggregate is exposed but not disturbed. Care should be taken that the joint surface is clean immediately before the fresh concrete is placed against it.
- Particular care should be taken in the placing of the new concrete close to the joint. This concrete should be particularly well compacted and if possible a vibrator should be used.
- Where the Purchaser considers that special preparation is necessary, i.e. for an in-situ structural connection, preparation should be carried out preferably when the concrete has set but not hardened, by spraying with a fine spray of water or brushing with a stiff brush, which is sufficient to remove the outer mortar skin and expose the larger aggregate. Where this treatment is impracticable, sand blasting or a needle gun should be used to remove the surface skin and laitance. Hacking of hardened surfaces should be avoided.



- A record shall be kept on site of the time and date of placing the concrete in each section of the work.

b) Expansion and contraction joints

- The expansion joints, contraction joints and other permanent structure joints shall be provided in positions as shown in the drawings.
- Joints shall be straight and vertical, except where other specified and concrete surfaces on both sides of the joint shall be flush. Where necessary, water stops of a type approved by the purchaser shall be embedded in the concrete. The water stop should be made of high quality material which must obtain its resilience through the service life of the structure for the double function of movement and sealing. The surface of water stops should be carefully rounded to ensure tightness of the joint even under heavy water pressure. To ensure a good tightness with or without movement of the joints the water stop should be provided with anchor parts. The cross-section of the water stops should be determined in accordance with the presumed maximum water pressure and joint movements. The complete works of fixed and welded connections must be carried out strictly in accordance with the manufacturer's instructions.
- All joints between structural steel and concrete parts shall be sealed by a suitable permanent flexible compound.

vi) Concreting at night

When approval is given to carry out concreting operations (under control of the purchaser) at night or in places where daylight is excluded, the contractor has to provide adequate lighting at all points of mixing, transportation and placing of concrete.

vii) Concreting in high ambient temperature

“IS: 7861 (part 1) – Concreting in hot weather” shall apply.

The temperature of the mixed concrete at the time of placement shall not exceed 40°C. The contractor shall take special measures in the mixing, placing and curing of concrete. These measures shall include the shading of aggregates, spraying of aggregates with water, cooling of the mix constituents (introduction of ice to the mixing water) and reduction of transportation time to the minimum. During placing suitable measures shall be provided to prevent premature setting of concrete placed in contact with hot surfaces. All concreting areas, formwork and reinforcement shall be shielded from the direct rays of the sun and sprayed with water when necessary.



viii) Protective measures for concrete

- a) In general, the cover of re-bars shall be as per IS: 456 taking into account the site conditions. However, the minimum concrete cover shall not be less than:
- | | |
|---|---------|
| Concrete parts above ground (external surface) | : 40 mm |
| Concrete exposed to underground and groundwater | : 50 mm |
| Slabs | : 20 mm |
| Beams | : 25 mm |
| Columns | : 40 mm |
- b) Immediately after the compaction of the concrete has been finished, the contractor shall ensure adequate protection from the weather. Excessive drying can lead to crack formation as a result of plastic contraction. The concrete surface shall be covered with a layer of sacking, canvas, straw mats or similar absorbent material, special protection sprays kept constant moist for at least 7 days.
- c) Curing compounds or other methods of preventing evaporation may be used if approved by the purchaser. Where formwork cannot be removed within 24 hours after placing the concrete, the formwork shall be kept shaded from the direct rays of the sun and shall be sprayed with water.
- d) Purchaser's approval to the use of a particular curing compound and to the method of application will only be given after the contractor has completed satisfactory site trials and a sample panel has stood for at least 28 days.
- e) Where large sections of concrete are poured, special precautions to the approval of the purchaser shall be taken to reduce and dissipate the heat generated by the setting and hardening of the concrete (e.g. built-in cooling water pipe system).
- f) The minimum amount of reinforcement shall be present to prevent shrinking cracks.
- g) No load of any kind, however light, shall be allowed on concrete which has not properly set and the contractor shall prevent any load to be imposed on the concrete structures until it has been declared by the purchaser to be ready to carry loads.

- ix) Concreting under-water
- a) Underwater concreting shall be done as per IS: 456. Underwater concrete must comply with the following characteristics:-
- The quantity of cement must be not less than 350 kg/m³ when using aggregate mixes with a maximum particle size of 40 mm.
 - The water-cement ratio must not exceed 0.6.
 - Preferred aggregates are those with continuous grading curves lying approximately in the middle of the favourable range.
 - Slump shall be as per clause 7.1 of IS: 456.
- b) Underwater concrete is to be placed continuously without interruption. For water depths up to 1 m the concrete may be placed without tremie. In the case of water depths exceeding 1 m, the concrete is to be placed in such a way that it does not fall freely through the water. The tremie must at all times dip sufficiently far into the freshly placed concrete to ensure that the concrete emerging from the tremie does not come into contact with the water.
- c) All work connected with the placing of concrete underwater shall be designed, directed and inspected with due regard to local circumstances and purposes. Work shall not proceed until all phases and methods to be used in the placing operations have been approved by the purchaser.

7.5.7.12 Concrete with special properties

i) General requirements

The pre-condition for obtaining concrete with special properties is that it should be made with the appropriate composition, that it is placed in such a way that segregation does not occur and further that it is fully compacted and given appropriate curing.

ii) Waterproof concrete

This concrete must meet the provisions of IS: 3370. Waterproof concrete must be sufficiently dense (impermeable).

iii) Waterproofing and protection of underground concrete structures

- a) Water aggressive to concrete should be kept away from the fresh concrete.
- b) Concrete which is exposed for a prolonged period to “very severe” chemical attack must be protected against direct access of the aggressive substances.

- c) The protection, which is to be laid as protection to all concrete surfaces in contact with the ground, shall consist of an approved waterproofing membrane. The membrane shall adhere to all concrete surfaces, including undersides of structures and other surfaces where concrete is cast in contact with the membrane.
 - d) Such membranes shall be PVC sheets of minimum 0.35 mm thickness with knobs of Maxlock.
 - e) The waterproof membranes shall be installed in strict accordance with manufacturer's instructions.
 - f) The membranes shall extend 15 cm above ground level.
 - g) When setting forms and reinforcing steel caution shall be exercised to avoid damage to the impervious membrane. The surface of the impervious membrane extending outside the forms shall be protected during subsequent operations.
 - h) Any puncture or damaged areas shall be cleaned and patched according to manufacturer's instructions.
- iv) Concrete with high wearing resistance
- a) Concrete which is exposed to severe mechanical action, e.g., due to intensive traffic, sliding of bulk materials, frequent impact blows or movements of heavy objects, or due to fast-flowing water carrying solids, or other causes, should possess high wearing resistance and correspond at least to grade 30.
 - b) The aggregate upto 4 mm size should consist predominantly of quartz or materials of at least equal hardness; the coarser particles should consist of stone or artificial materials possessing high abrasion resistance. In the case of particularly severe mechanical action, it will be necessary to use special hard materials. The particles of all types of aggregate should have a moderately rough surface and be of compact shape. The combined aggregate should be as coarsely graded as possible.
 - c) Furthermore, the concrete should be as stiff as possible, in order that there will be no concentration of cement slurry or water in the top layer. The concrete should be kept moist for at least 7 days after placing.

7.5.7.13 Finishing of formed surfaces

- i) Fins and other surface projections shall be removed from all formed surfaces except exterior surfaces that shall be covered with earth backfill. Exterior surfaces that shall be exposed above grade and all interior surfaces, except those not usually exposed to view, shall be cleaned and rubbed. Rubbing shall produce a smooth, uniform surface free of marks, voids, surface glaze, and discolorations.

- ii) Rubbing shall be done by hand with a carborundum stone using only the mortar produced by the rubbing action and the application of water.
- iii) Projecting ends of all form ties shall be removed. The resulting recesses shall be cleaned, wetted, and filled with patching mortar. Patches on rubbed surfaces shall match the texture of the adjacent concrete.

7.5.7.14 Finishing of unformed surfaces

- i) No surface treatment shall be required for buried or permanently submerged concrete. As a minimum, unformed surfaces shall be finished by screeding and floating. Surfaces requiring a trowelled finish shall be finished by screeding, floating, and trowelling.

Float finished and screeded surfaces shall be finished to provide a flat profile within a 6 mm deviation as measured from a 3 meter straightedge. Trowel finished surfaces shall be finished to form a flat plane. The surface profile shall not deviate more than 3 mm when measured from a 3 meter straightedge.

- ii) Screeding

Screeding shall provide a concrete surface conforming to the designated elevations and contours with all aggregates completely embedded in adjacent mortar. Surface irregularities in screeded surfaces shall be limited to the tolerances specified.

- iii) Floating

- a) The surfaces shall be screeded and given an initial float finish as soon as the concrete has stiffened sufficiently to work. Coarse aggregate disturbed by the float or causing a surface irregularity shall be removed and replaced with mortar. Initial floating shall produce a surface of uniform texture and appearance.
- b) Initial floating shall be followed by a second floating at the time of initial set. The second floating shall produce a smooth float finish of uniform texture and color.
- c) Floating shall be performed with hand floats or suitable mechanical compactor floats.

- iv) Trowelling

The exposed portions of the tops of equipment bases, tops of interior curbs, and the surfaces of interior slabs not receiving a separate finish shall receive a steel trowel finish. Trowelling shall be performed after the second floating when the surface has hardened sufficiently to prevent excess cement from being drawn to the surface. Trowelling shall produce a dense, smooth, uniform surface free from blemishes and trowel marks.



Surfaces to be covered with neoprene-hypalon coatings shall be lightly trowelled but not burnished.

v) Brooming

Brooming shall follow the float finish for exterior surfaces where a nonskid surface is required. Brooming shall be done with an acceptable steel or fiber broom not less than 450 mm wide. Brooming ridges shall be transverse to the normal traffic direction and shall be between 1.5 mm and 3 mm deep. Adjacent strokes of the broom shall overlap slightly. Broomed surfaces shall be free of porous spots, irregularities, depressions, and small pockets or rough spots.

vi) Aggregate exposure

Surface mortar shall be removed and the aggregate exposed from surfaces that shall be covered with mortar, concrete, or grout at a later time.

vii) Edging

Unless specified to be beveled, exposed edges of floated or troweled surfaces shall be edged with a tool having a 6 mm corner radius.

viii) Finishing mortar

Finishing mortar shall be added if there is not sufficient mortar available from the concrete mix. The proportions for this finishing mortar shall be 102 kilograms of concrete sand to one sack of Portland cement, mixed with enough water for proper application. Slump for finishing mortar shall not exceed 50 mm.

7.5.7.15 Separate finishes

- i) Certain slab surfaces shall be finished with a separate concrete finish or floor covering.
- ii) Base slab surfaces shall be ground or filled until each surface is within the specified tolerances. Low areas shall be filled. High spots shall be ground slightly lower than required and then filled and smoothed to the proper elevation and surface.
- iii) Surfaces that receive epoxy set quarry tile and resilient tile shall be flat with a profile that shall not deviate more than 3 mm from a 3 meter straightedge placed on any part of the surface. These surfaces shall be either trowel finished concrete at the elevation indicated on the drawings or a float finished surface set 3 mm low and leveled with trowel finished fill material.
- iv) Surfaces that receive a mortar set quarry tile, ceramic tile, or terrazzo finish shall be given a smooth, tight, and uniform float finish with a profile tolerance of 6 mm as measured from a 3 meter straightedge.



7.5.7.16 Formwork

- i) Design and construction
 - a) For stability and type of formwork and support framing used, IS: 14687 is to be observed.
 - b) The formwork and the supporting structure are to be so dimensioned as to be able to withstand all vertical and horizontal forces safely.
 - c) Supporting structures shall be sufficiently rigid to maintain the forms in their correct position and to be true to shape and dimensions so that the final concrete is within the limits of the tolerances specified under “Permissible tolerances”.
 - d) The contractor shall submit in sufficient time in advance for the approval of the Purchaser the calculations, designs and details of the methods adopted and materials proposed for the formwork.
 - e) Particular attention must be paid to the formwork supports and braces to avoid any slip when the concrete is poured.
- ii) Materials for formwork
 - a) Forms shall be constructed from steel or from sound timber well seasoned and free from shakes. Plywood lining for forms shall be of timber which is resin-bonded and water repellent.
 - b) Formwork surfaces in contact with concrete shall be free from adhering grout, projecting nails, splits or other defects.
 - c) Joints shall be sufficiently tight to prevent the leakage of cement grout. Connections shall be constructed to permit easy removal of the shuttering and shall be either nailed, screwed, bolted, or otherwise secured so as to be strong enough to retain the correct shape during consolidation of the concrete. Where a slope exceeds 1 V : 2 ½ H formwork shall be provided for the top of the concrete faces and anchored to prevent flotation.
 - d) The details of fair faced concrete facades have to be to the satisfaction of the Purchaser. The concrete surface for facades has to be absolutely stainless and all efforts have to be taken to achieve this.
- iii) Grading of formwork and of finished concrete surfaces

Quality of formwork, materials to be used and treatments of surface are graded according to the finish of the concrete surface as given in IS: 14687.

The type and treatment of the formwork lining (plywood, metal, plastics, etc.) should be appropriate to the grade of concrete finish required.

iv) Preparation and inspection of formwork

Before concrete is placed, all formwork shall be inspected to see if it is built according to the approved plans and to see if it has been cleaned and is free from sawdust, shavings, dust, mud, earth or other contamination and properly oiled. Contact surfaces of panels shall be treated with a suitable release agent (e.g. non-staining mineral oil) where applicable. Surfaces which are not oiled shall be wetted thoroughly to prevent warping.

v) Erection and placing of formwork

- a) All formwork shall be erected and placed in accordance with the construction drawings approved by the Purchaser. Shuttering shall be true to line and braced and strutted to prevent deformation under weight and pressure of the wet concrete, live-loads, wind and other forces. The deflections shall not exceed 3mm.
- b) The formwork for beams and slabs shall be erected so that the form on the sides of the beams and of the soffits of slabs can be removed without disturbing the beam soffit.
- c) If the formwork for columns is erected to the full height of the columns, one side shall be provided with openings for concreting in order to guarantee a proper compaction of the poured concrete.
- d) Formwork for walls and elsewhere shall be arranged for a maximum concreting height of 2.5 m in a single pour. Where necessary, panel openings are to be provided in the forms for cleaning, inspection, access of vibrators etc.
- e) Before placing of concrete, bolts, ties and fixings shall be positioned and all devices used for forming openings, holes, pockets, chases, recesses etc. shall be fixed to the formwork carefully.
- f) Panels shall be put together to ensure a perfect fit at the joint and fixed in both directions.
- g) Where concrete surfaces will be exposed to view (permanently exposed surfaces) the formwork shall be such as to produce a completely true, smooth surface, free from perceptible irregularities or to show clearly the desired texture. Such formwork shall be marked on the drawings as "Fair-faced formwork".
- h) Where concrete surfaces will be covered (non-exposed surfaces), the formwork shall be referred to and marked as "Sawn formwork".

- i) Internal spacers and ties, if any, shall be so arranged that after removing of the forms no holes shall extend through the concrete, in the case of watertight concrete or to be closed by plastic plugs and epoxy mortar in all other cases.
- j) All formwork will be inspected and approved by the purchaser before concrete placing commences but this shall not relieve the contractor of any of his responsibilities under the contract.
- vi) Striking of formwork
- a) Formwork shall not be removed until the concrete has sufficient strength to carry its own weight plus any constructional or designed loads likely to be applied with a normal factor of safety. It shall be removed in such a manner that no shock or injury shall result to the concrete.
- b) Before removal of the formwork, the concrete shall be examined and removal shall proceed only on the instructions and under the supervision of a competent person.
- c) In accordance with IS: 456 clause 11.3.1, the striking period for cast in-situ concrete under certain conditions may be taken as follows:-

<u>Type of formwork</u>	<u>Minimum period before striking formwork</u>
Vertical formwork to columns, walls, beams	16 to 24 hours
Soffit formwork to slabs (props to be refixed immediately after removal of formwork)	3 days
Soffit formwork to beams (props to be refixed immediately after removal of formwork)	7 days
Props to slabs:	
Spanning up to 4.5 m	7 days
Spanning over 4.5 m	14 days
Props to beams and arches:	
Spanning up to 6 m	14 days
Spanning over 6 m	21 days

- d) Special care is necessary in the case of components which have to carry nearly the full calculated load as soon as the formwork is struck.



- e) Columns, piers and walls are to be struck before the beams and slabs supported by them. Scaffolds, formwork supports and self-supporting floor formwork are to be carefully lowered by releasing the devices.
- f) Extreme care shall be taken to avoid chipping of corners during removal of formwork.
- g) To keep deflections through creep and shrinkage to a small amount, auxiliary supports should be left in place or immediately repositioned after striking.

7.5.7.17 Reinforcing steel

i) General

Reinforcing steel used in reinforced concrete shall comply with the following standards:-

Deformed bars shall conform to IS: 1786.

Mild steel shall conform to IS: 432.

Mesh reinforcement shall conform to IS: 1566.

In the event of presence of alkalinity or corrosive nature of soil, fusion bonded epoxy coated rebar shall be used for all foundations up to plinth level.

ii) Binding wire

Plastic coated binding wires to be used for epoxy coated rebar.

Binding wire for general use shall be 1.6 mm diameter galvanized annealed wire.

iii) Reinforcement supports

- a) Reinforcement supports shall include all spacers, chairs, ties, slab bolster, clips, chair bars, and other devices for properly assembling, placing, spacing; supporting, and fastening the reinforcement.
- b) Spacers shall be cast from concrete of the same quality as that in which they will be embedded.
- c) Concrete block spacers shall be cast in metal moulds with an approved means of separating blocks and of ensuring that the blocks are of the proper size.
- d) Coated binding wire shall be incorporated into the blocks to enable them to be securely attached to vertical or horizontal bars and the contractor shall demonstrate both that the blocks are of the requisite strength and that the means of attachment to the reinforcement are adequate.



iv) Certificates

Each consignment of steel reinforcement shall be accompanied by a test certificate from the manufacturer showing that the steel has been tested and analyzed and the date of such tests and analyses and that such tests and analyses comply in all respects with the standards. The following tests shall be carried out on reinforcement:-

- Cast analysis
- Carbon equivalent value
- Tensile strength, yield stress, elongation
- Bend test
- Bond classification
- Chemical analysis

v) Epoxy coating of reinforcement

- a) Wherever epoxy coated reinforcement is used, reinforcing bars, fabric and special steel connections shall be protected against corrosion by means of an epoxy coating as per IS: 13620.
- b) At the same time, the contractor shall furnish written certification from the coating applicator that the coated reinforcement bars were cleaned, coated and tested in accordance with the requirements of this specification.
- c) Coating materials shall be heat-cured epoxy resin powders applied by electrostatic spray process. The thickness of the coating shall be 250 μm .
- d) Reinforcement bars which are to be coated shall be clean and free from rust, scale, oil, grease and similar contaminants. The surface shall be abrasive blasted to Swedish Standard SA3 or equivalent. As soon as possible after cleaning and before any visible oxidation to the surface occurs, the steel shall be coated with a fusion-bonded powder epoxy coating applied by electrostatic process.

vi) Stock of reinforcing steel

In order to ensure due progress of the works, the contractor shall at all times maintain on the site a stock of reinforcing steel sufficient for the following month's work. No reinforcing steel shall be used upon the works until it has been accepted as satisfactory by the purchaser.



vii) Rejection

The purchaser at his discretion may order random testing of the reinforcement steel and in the event of any failed test reject the entire lot notwithstanding the manufacturer's or coating applicator's certificates.

The contractor shall remove all rejected reinforcing steel from the site without delay at his own expense.

viii) Production handling of epoxy coated bars

Bars shall be handled and stored in a manner to prevent damage to the coating. Bars or coating damaged in handling or other operations shall be satisfactorily repaired to the satisfaction of the purchaser. All systems for handling the coated bars shall have padded contact areas wherever possible. All bundling bands shall be padded and all bundles shall be lifted with a strong-back or spreader bar with a minimum of three supports to the bundle. The bars or bundles shall not be dropped or dragged. Extra care in handling of these bars will be beneficial to the contractor in reducing or eliminating in place coating repairs.

ix) Storage

All bars for reinforcement and steel fabric reinforcement shall be stored on the site under cover on timber or concrete supports suitably spaced and of sufficient height to keep the steel not less than 150 mm clear of the ground.

x) Bar-bending schedules

The contractor shall prepare bar bending schedules based on the detailed reinforcement drawings. These shall be presented to the purchaser for approval. Approval of these schedules by the Purchaser in no way absolves the contractor from full responsibility for their completeness and correctness in every way nor shall any claim for extra cost or time be allowed on the grounds of such errors or discrepancies which may arise between drawings and schedules.

7.5.7.18 Water stops

- i) Water stops shall be PVC or equivalent and shall be eye-letted with a minimum 25 cm width. Type and manufacturer shall be submitted to the purchaser's approval.
- ii) All intersection pieces shall be prefabricated by the manufacturer and only welding of butt-joints in running lengths will be allowed to be carried out on the site.
- iii) The site welding of butt-joints shall be executed by using the manufacturer's purpose-made electrically heated jig and work shall be done by a competent and trained personnel only. The manufacturer's instructions shall be carefully observed.

- iv) The wings of the water stops shall be formed with corrugations or bulbs to achieve a good bond. Moreover, the water stops shall conform to the following requirements:-
 - a) The tensile strength not less than 10 N/mm^2 when tested.
 - b) The ultimate elongation shall not be less than 22% when tested.
 - c) The tear resistance shall not be less than 2 N/mm^2 when tested.
 - d) The material shall not crack when tested.
 - e) Under accelerated elongation, the tensile strength shall not be less than 8 N/mm^2 and the ultimate elongation shall not be less than 200%.
- v) The water stops shall be installed so that they are securely held in position during the placing of concrete which shall be fully and properly compacted around the water stops to prevent voids or porous areas. Adequate clearance between the reinforcement and all the water stops shall be kept to permit proper compaction of concrete. No holes or nailing shall be made through any water stop for fixing purposes. Jointing by lapping two pieces of water stops shall not be permitted. The free edges of water stops shall at all times be protected from direct sunlight.

7.5.7.19 Curing

Concrete shall be protected from loss of moisture for not less than 7 days after the concrete is placed.

Trowelled surfaces, except those that receive a separate finish or coating, shall be cured with a membrane curing compound. Float finished surfaces, except those that receive a separate finish, may be cured with either a membrane curing compound or with water. Only water curing shall be used if the surface receives a separate finish.

i) Water curing

Water saturation of concrete surfaces shall begin as quickly as possible after initial set of the concrete. Water curing shall begin within 12 hours in dry weather and within 24 hours in damp weather. The rate of water application shall be regulated to provide complete surface coverage with a minimum of runoff. The application of water may be interrupted for surface rubbing. The concrete surface shall not be permitted to dry.

After the rubbing has been completed, rubbed surfaces shall be covered with burlap and kept saturated for the remainder of the curing period.

ii) Membrane curing

Membrane curing compound shall be applied within 30 minutes after final finishing of the surface or as soon as possible after finishing without causing damage to the surface. Membrane curing compound shall be spray applied at coverage of not more



than 7.4 square meters per liter. Membrane curing shall not be used on surfaces that shall be covered at a later date with mortar, concrete, damp-proofing, tile, or any coating. Membrane curing shall not be used on cast-in-place concrete bases for field erected tanks.

7.5.7.20 Floor sealer

All concrete floors shall be given two coats of clear floor sealer in addition to that applied as membrane curing compound. The first coat shall be applied at the end of the curing period before any traffic is permitted on the floor. The second coat shall be applied after the floor has been cleaned in preparation for the final inspection. Floor sealer shall be applied in strict accordance with the manufacturer's recommendations.

7.5.7.21 Repairing of damaged or defective concrete

- i) Concrete which has completed its final setting shall be inspected by the purchaser and any cracks, honeycomb areas, segregations, etc shall be marked. No repairs shall be carried out until direction by the purchaser.
- ii) Surface defects in formed concrete shall be repaired to the satisfaction of the purchaser within 24 hours. Concrete that is porous, honeycombed, or otherwise defective to a depth in excess of 25 mm shall be cut out and removed to sound concrete. Edges shall be square cut to avoid feathering. Cut surfaces shall be coated with epoxy bonding compound before the concrete is placed.
- iii) Defective concrete shall be replaced within 48 hours after the forms have been removed.
- iv) Concrete repair work shall not interfere with the curing of surrounding concrete. Mortar and concrete used in repair work shall be adequately cured and shall be finished to match adjacent surfaces.

7.5.7.22 Waterproofing

A waterproofing seal shall be provided for all below grade structures where applicable by external tanking with PVC sheets of 1.0 mm thickness with knobs for membrane type water-proofing. In addition, joints in deep underground structures shall be provided with structural water-proofing.

7.5.7.23 Damp Proofing

Damp-proof course 40 mm thick, consisting of cement concrete 1:2:4, with admixture of approved water-proofing compound shall be laid at plinth level for walls of all buildings for protection of super-structure against moisture and dampness.

7.5.7.24 Standard grouting

- i) Ordinary grout shall be provided for miscellaneous structure base plates viz. operating platforms (not supporting equipment), pipe supports upto 2.5 m height (above concrete top), cross-over, staircases and ladders.

The proportions of grout shall be such as to produce a flowable mixture consistent with minimum water content and shrinkage. Based on requirement for obtaining non-shrink grout, aluminium powder may be used as an admixture. The grout proportions shall be limited as follows:-

<u>S. N.</u>	<u>Use</u>	<u>Grout thickness</u>	<u>Mix proportions</u>	<u>W/C ratio</u>
a)	Fluid mix	Under 25 mm	One part Portland cement to one part of sand	0.44
b)	General	25 mm and over but less than 50mm	One part Portland cement to 2 parts of sand	0.53
ii)	a)	Sand shall be such as to produce a flowable grout without any tendency to segregate.		
	b)	Sand for general grouting purposes, shall be graded within the following limits:-		
		Passing IS 2.36 mm sieve	:	95 to 100%
		Passing IS 1.18 mm sieve	:	65 to 95%
		Passing IS 300 micron sieve	:	10 to 30%
		Passing IS 150 micron sieve	:	3 to 10%
	c)	Sand for fluid grouts shall have the fine material passing the 300 and 150 micron sieves at the upper limits specified above.		
iii)	Surfaces to be grouted shall be thoroughly roughened and cleaned of all foreign matter and laitance.			
	Anchor bolts, anchor bolt holes and the bottom of equipment and column base plates shall be cleaned of all oil, grease, dirt and loose material. The use of hot, strong caustic solution for this purpose will be permitted.			
iv)	Prior to grouting, the hardened concrete surfaces to be grouted shall be saturated with water.			
	Water in anchor bolt holes shall be removed before grouting is started.			
v)	Forms around base plates shall be reasonably tight to prevent leakage of the grout.			
vi)	Adequate clearance shall be provided between forms and base plate to permit grout to be worked properly into place.			

- vii) Grouting, once started, shall be done quickly and continuously to prevent segregation, bleeding and breakdown of initial set. Grout shall be worked from one side of one end to the other to prevent entrapment of air. To distribute the grout and to ensure more complete contact between base plate and foundation and to help release entrapped air link chains can be used to work the grout into place.
- viii) Grouting through holes in base plates shall be by pressure grouting.

7.5.7.25 Special non-shrinking grout

- i) Special grout, where specified on the drawings, shall be provided in strict accordance with the manufacturer's instructions/ specifications. Pre-mixed grout Conbextra GP-2 of 'FOSROC' make or equivalent of crushing strength 650 kg/cm² for major equipment foundations and Conbextra GP-1 having crushing strength of 450 kg/cm² for other foundations where concrete grade M25 or higher is provided.
- ii) Forms and shims used to obtain adequate clearance shall not be removed and the anchor bolts shall not be tightened for at least three days after placing the grout. After the removal of forms and shims, area occupied by shims shall be filled and the area between the base and edge of the foundation shall be finished smooth to allow drainage away from the base. Attachment of interconnecting piping of machinery and complete load transfer of machinery shall not be done before the bolts are tightened. During this period, grouting work shall be properly cured using rags/gunny bags.
- iii) In view of extremely small proportion (about 0.01% by weight of cement) of the aluminum powder required, it is necessary to take all precautions to ensure thorough mixing. It is advisable to mix the blend of aluminum powder thoroughly with sand and cement before water is added because aluminum powder has a tendency to float on water.
- iv) Proprietary material of approved manufacture used as an admixture to obtain non-shrinking grout shall be mixed in the proportion of 1:1:1 (1 cement: 1 admixture: 1 sand), or as per manufacturer's instructions.
- v) Pre-mixed non-shrinking grout shall be used all as per manufacturer's instructions and without any additional materials/admixtures such as cement, sand and aggregates etc.

7.5.8 Steel and Other Metals

7.5.8.1 Design and other minimum requirement

- i) Structural steel design will be carried out as per the National Building Code with specific consultation to IS: 800 (latest) unless noted otherwise. Design of structures in electrical substation will be as per IS: 802 (latest). All work shall be done as per relevant latest IS Codes, unless otherwise specified.



- ii) Lateral forces along with the length of the building will be resisted by bracings in horizontal and vertical frames. The transverse lateral load will be resisted by stiff jointed frame action. Additional bracing or moment connection will be used to assure stability of the structures.
- iii) Steel will conform to Grade-A of IS: 2062 (latest) for rolled steel members or plates upto 20 mm thickness. For plates above 20 mm thickness and welded construction steel conforming to Grade-B (killed and normalized) of IS: 2062 (latest) shall be used except for crane girders where Grade-C (IS: 2062) steel shall be used. Steel shall be procured from SAIL or any other approved main producers.
- iv) Chequered plate shall conform to IS: 3502 (latest) and minimum thickness of chequered plate for floorings, covers etc shall be 6 mm O/P.
- v) Hand-railings shall conform to IS: 1239 (latest) (Medium) black steel pipe and flush welded construction, ground smooth using 32 mm nominal bore of 42.2mm outside diameter pipe, provided with double rail and pipe posts. Top rail shall be provided at 1065 mm above platform and intermediate rail 535 mm below the top rail or as approved and pipe posts spaced not more than 1200 mm centre to centre.
- vi) Shop connections will be all welded and field connections will generally be bolted unless otherwise. Field bolts, wherever provided shall be high tensile of 20 mm diameter or of higher diameter and of property class 8.8 (minimum) as per IS: 1367 (latest) for all major connections. All bolts, nuts and washers shall be procured from the manufacturers as approved by purchaser. The bolted joints shall be designed for friction type connection and the HT bolts shall be tightened to develop the required pretension during their installation. However, the nominal connections in the field like purlins, stairs, wall beams will be done by 16 mm diameter MS black bolts (minimum property class 4.6) conforming to IS:1363 (latest) unless specified otherwise. All removable type connections shall be with bearing type HT bolts of grade 8.8 (minimum).
- vii) a) Welding shall be in accordance with the recommendation of IS: 816 (latest) 'Code of practice for arc of metal arc welding for general construction in mild steel' and IS: 9595 (latest) 'Recommendation for metal arc welding of carbon and carbon manganese steels'. Built-up members will be fabricated using submerged arc welding procedure. All electrodes, flux, bare wire etc shall be procured by the contractor only from approved manufacturers. All butt-welds in beams, girders and columns will be of full penetration. All butt-welds will be radiographically or ultrasonically tested as per IS-822 and standard practice.

b) The bare wire electrodes for submerged arc welding shall conform to IS: 7280 (latest). The combination of wire and flux for submerged arc welding shall be as follows:

Filler wire shall be of classification AWS-A-5.17-EH14 and flux shall be of agglomerated type of classification AWS-A-5.17F7 A2-EH14.



- c) Low hydrogen electrodes as approved by the purchaser shall invariably be used in the following cases:-
- For welding of all important joints such as butt-joints in columns (flange or web), butt-joints in main frame beams (flange or web) etc.
 - For welding the steel having thickness more than 20 mm.
- d) In case of fillet weld between two components, the thickness of the thicker part shall be considered as the limit for (ii).
- e) Minimum preheat and interpass temperature for welding over 40 mm to 63 mm (thickness of the thicker part at the point of welding) shall be 66°C and for over 63 mm, it shall be 110°C. However, higher preheat and interpass temperature may be required due to joint restraint etc. and shall be followed as per approved welding procedure.
- f) Minimum tests to be carried out during fabrication and erection of structural steel:
- Steel
Ultrasonic test : Plates above 25 mm thickness shall be subject to ultrasonic test as per ASTM-A435 or equivalent to check the presence of lamination.
 - Fillet weld
Dye-penetration test: 5% of the total length, dye-penetration test shall be carried out to the root run.
 - Butt weld
Dye-penetration test: 10% of the total length, dye-penetration test shall be carried out to the root run after back gouging.

Radiography: Generally, splicing shall not be provided in tension flange of bunker girder. Spot radiography shall be carried out on 100% joints in tension zone and 10% joints in compression zone. Minimum 300 mm length shall be spot radiographed. When radiograph is not possible, ultrasonic test shall be carried out after grinding the surface with prior approval of purchaser.

Ultrasonic test: 10% of all other butt-welds shall be subject to spot radiographic test and the entire balance butt-weld for ultrasonic test.



- viii) All galvanizing shall be uniform and of standard quality and shall withstand test in accordance with IS: 2633. Zinc coating over galvanized surface of structural members and threaded fasteners shall not be less than 610 gm/m² and 375 gm/m² of surface area respectively.
- ix) For all field connections whether welded or bolted, 80% of the shop design strength shall be considered.
- x) All design drawings along with detailed supporting design calculations will have to be submitted to Purchaser for approval, before taking up the fabrication and erection drawings.
- xi) All fabrication and erection drawings along with detailed supporting design/ connection calculations will have to be submitted to purchaser for approval before taking up the fabrication work.

7.5.8.2 Design of connection

- i) Fabrication drawings shall be prepared according to the provision of IS: 800, IS: 816, IS: 9595, IS: 1367 and IS: 9178.
- ii) Connection of vertical bracings with connecting members and diagonals of truss members shall be designed for full tensile capacity of the bracings.
- iii) Size of fillet weld for flange to web connection for built-up section shall be as follows:-
 - a) Full shear capacity or actual shear whichever is more for box section.
 - b) 80% of full shear capacity or actual shear (if indicated in drawings) or 0.5 times of the web thickness whichever is more for I section weld shall be double fillet.
 - c) All welds shall be continuous. The minimum size of the fillet weld shall be 8 mm.
- iv) Shear connections shall be designed for 75% of section strength or actual shear for rolled sections and 80% of section strength or actual shear whichever is higher for built-up section or rolled section with cover plates.
- v) Moment connections between beam and column shall be designed for 100% of moment capacity of the beam section.
- vi) All butt-welds shall be full penetration butt-welds.
- vii) The connection between top flange and web of crane girder shall be full penetration butt-weld and for bottom flange, connection may be fillet weld.



- viii) Connection of base plate and gusset members with the columns shall be done considering that total load gets transferred through weld.
- ix) Splicing: All splicing work shall be full strength. Field splicing shall be done with web/flange cover plates. For exceptional cases, the field splicing shall be designed for 50% of load carried by the cover plates and remaining 50% load through full penetration butt-weld. Shop splicing for all sections other than rolled shall be carried out by full penetration butt-welds with no cover plates. Splicing for all rolled sections shall be carried out using web and flange cover plate.
- x) Shop primer paint shall be one coat of primer as per Table 1.

7.5.9 Material Storage Structures

7.5.9.1 Bunkers

A set of bunkers of required capacity for storage of coal shall be provided. Bunkers shall be circular in plan with hopper bottom. To facilitate easy and continuous flow of material, the angle made by the hopper wall with the horizontal (valley angle in the case of square and rectangular hopper bottoms), shall preferably be 15° more than the angle of internal friction of the materials, but should not be less than 60° to the horizontal.

- i) The design of the bunker walls and supporting structure shall conform to IS: 9178 (part I and II).
- ii) Maximum pressures during filling and emptying shall be considered for the design of hopper bottom, and design of side walls.
- iii) Check for the maximum pressure should be made for the rapid filling and pneumatic emptying condition.
- iv) Effects causing increase in bin loads and decrease in bin loads as per IS: 9178 (part I) shall also be considered.
- v) Wind load on bins shall be calculated in accordance with IS: 875.
- vi) Seismic load shall be calculated in accordance with IS: 1893.
- vii) Bunker shall be provided with minimum 4 mm thick stainless steel liner.
- viii) Density of coal for storage volume calculation shall be 800 kg/m³ and shall be 1200 kg/m³ for weight calculation.

7.5.9.2 Stainless steel liner in the coal bunkers shall be 4 mm thick of grade AISI 304; finish grade 2B (cold rolled, annealed and pickled and skin passed) and shall be provided on the inner faces of entire inclined portion of hoppers and mouth of the hoppers, without allowing any projections in coal flow path. The electrodes classification as per AWS shall be as follows:-

- i) For welding of stainless steel to stainless steel : E308L



- ii) For welding of stainless steel to mild steel : E309

7.5.10 Boiler and ESP Support Structures

7.5.10.1 Boiler and ESP support structures shall be designed for the following:

Live/ imposed loads.

Dead load.

Static and dynamic loads of piping, movable equipment and maintenance parts.

Loads from cable trays and walkways.

Ash water piping supported on the outermost row of boiler columns.

All ESP hoppers filled up with ash upto the top of the hoppers or the bottom of electrodes (whichever is more) using a bulk density of not less than 1350 kg/cum for the ash, along with additional ash build-up from the end of the third field upto the inlet duct bottom level at a natural repose angle (not less than 30 degree to horizontal in any case).

Ash load at bottom ash hopper and pent house of the boiler shall be as mentioned in the mechanical chapter of the specifications.

Seismic and wind loads as specified elsewhere in the specifications.

Temperature variation of +/-25 deg. C for atmospheric temperature variations.

Temperature variations under ESP operating conditions.

The loads listed above indicate the minimum requirements.

7.5.10.2 Boiler supporting structures shall be so configured that the temperature of steel does not exceed 60⁰C unless specified otherwise. Brackets shall be provided on both sides of the outermost row of columns of both the boiler and ESP for supporting cable trays and walkways, at a height not exceeding 10.0 m. The exact levels shall, however, be decided during detailed engineering. Each ESP hopper shall be supported at four corners by providing four columns from the ground.

7.5.10.3 Purchaser's ash water piping, part or full ash slurry piping, dry ash piping and supply air/ instrument air piping shall be supported on boiler supporting structures in boiler area and ESP supporting structures in ESP area. Loads from these pipes shall be considered by the bidder in the design of the supporting structures of boiler and ESP. The load data of these pipes shall be furnished by purchaser to the bidder during detailed Engineering.

7.5.10.4 The bracings in boiler structure shall be provided such that under no circumstances normal/convenient access to all points in the boiler is blocked or obstructed.



- 7.5.10.5 In design of boiler/ ESP support structures, dynamic piping loads need not be considered acting simultaneously with wind or seismic loads. Increase in permissible stresses shall be allowed in load combinations where dynamic piping loads are considered and shall be as permitted under seismic load conditions.
- 7.5.10.6 Design criteria for foundations and some other facilities/ areas are covered separately in this specification.
- 7.5.10.7 Plinth level of all buildings shall be kept at least 500 mm above the finished grade/ formation level.

Finished floor level of boiler area paving shall be kept about 200 mm lower than the finished floor level of main plant buildings.

- 7.5.10.8 Steel structures shall be detailed and connection and joints provided as per the provisions of IS:800, IS:816, IS:9595, IS:1367, and IS:9178 and as per following requirements:
- i) Connection of vertical bracings with connection members and diagonals of truss members shall be designed for full tensile capacity of the bracings unless actual loads are indicated on the drawings.
 - ii) Size of fillet weld for flange to web connection for built up section shall be as follows:
 - a) For box section weld size shall be designed for 60% of full shear capacity or actual shear whichever is more. Where fillet weld is not possible, full penetration butt weld shall be provided.
 - b) For built up I section, weld size shall be designed for 80% of full shear capacity or actual shear, (if indicated, in drawings) whichever is more. However, weld size shall not be less than 0.5 times the web thickness. Weld shall be double fillet.
 - c) All welds shall be continuous unless otherwise specifically approved. The minimum size of the fillet weld shall be 6mm.
 - iii) Shear connections shall be designed for 60% of section strength for rolled sections and 80% of section strength for built up section or rolled section with cover plates. However, if load is more than above, the connection shall be designed for actual load.
 - iv) Moment connections between beam and column shall be designed for 100% of moment capacity of the beam section. This can be achieved either by direct butt welding of the top flange of beam with column flange or by providing top moment plate with suitable notch for additional weld length.
-



- v) All butt welds shall be full penetration butt welds.
- vi) The connection between top flange and web of crane girder shall be full penetration butt weld. Bottom flange, connection with web can be fillet weld or butt weld as directed by purchaser.
- vii) Connection of base plate and associated stiffeners with the columns shall be designed considering the total load transferred through welds. However, minimum weld size (double fillet) shall not be less than 0.6 times the thickness of stiffeners.
- viii) All splicing works shall be full strength. Field splicing shall be done with web and flange cover plates for full strength. In exceptional cases, the field splicing shall be designed for 50% of load carried by the cover plates and remaining 50% load through full penetration butt weld. Shop splicing for all sections other than rolled shall be carried out by full penetration butt welds with no cover plates. Splicing for all rolled sections shall be carried out using web and flange cover plate.

7.5.10.9 Bidder shall consider additional loads, from the purchaser's ash handling facilities expected in the boiler area, in the design of structures to be provided by him. These ash handling facilities include among others, economizer ash slurry tanks, bottom ash cooling water overflow tanks, bottom ash hoppers (wet or dry), bottom ash slurry trenches or pedestals. The loading data of these handling facilities shall be furnished to the bidder by the Purchaser during detailed Engineering. Similarly the loads for ash handling system equipment (to be located next to ESP casings) in ESP area like wetting head/ collector tank towers, dry buffer hoppers shall also be considered by the bidder.

Further the levels of top of foundations in boiler area and ESP area shall be decided by bidder taking into consideration the bottom levels and slopes of the bottom ash slurry trenches (if applicable) and fly ash slurry trenches.

7.5.11 Architecture

7.5.11.1 Architectural concepts

- i) Layout of the plant area shall have definite hierarchy of road network depending upon its usage, aesthetic, visual sensibilities for creating road vistas, focal points, building back drops, building frames. General layout shall be evolved taking over the basis of landform and local climate and due consideration shall be given to orientation and wind direction. The resulting built mass shall present a definite image with distinct vocabulary in the form of landmarks, nodes and skyline.
- ii) Main plant building shall be architecturally treated in such a way that it retains a monumental scale, yet presents a pleasing composition of mass and void with

suitable and functionally designed projections and recesses. The overall impact of the building shall be one of aesthetically unified architectural composition having a comprehensible scale, blending tonal values with the surroundings and taking full consideration of the climatic conditions, the building orientation and the existing structures nearby.

- iii) All other buildings and structures shall be architecturally treated in such a way so as to be in complete harmony with the main plant, surrounding structures and environment. Local architectural characters and materials may be judiciously imbibed. The building shall be designed initiating an architectural control common to all buildings. The architectural control shall be clearly spelt out in terms of scale, man and form.
- iv) Overall colour scheme of the plant and other buildings shall be designed judiciously and in a comprehensive manner taking into account the mass and void of buildings, its facade, equipments, exposed structural elements, piping, trestles, bus ducts and other service elements.
- v) Overall emphasis shall be on developing eco-friendly architecture, merging with the nature with its own sustainable energy management systems.

The scheme shall be conceptually finalised in totality including that of equipments so that the proper coordination with other agencies can be taken up at appropriate time.

7.5.11.2 Architectural design

- i) Natural light shall be used to the maximum extent especially in the form of north light/ sky light. For adequate light and ventilation, National Building Code recommendations shall be followed.
- ii) Entrance canopies, chajjas (projections, recesses) over openable windows and door openings on exterior facades shall be provided.
- iii) All the buildings shall be architecturally designed to meet the National Building Code (SP: 7) norms and local building bye laws, wherever applicable.
- iv) Architectural design and detailing aspects of all the buildings shall be rendered through professional services of an architect.
- v) Statutory requirements may be required to be met with, wherever essential. The architect consultant shall be of national/ international repute having experience in similar kind of works. The consultant shall evolve the design philosophy based on Purchaser's guidelines and shall present it in the form of presentation drawings, prospective views, 3-D models and detail drawings.
- vi) An architectural design intent memorandum shall be submitted to the purchaser which shall include proposals for the following scheme components: shape, form,

color, and basic materials for interior and exterior architecture along with an appropriate landscaping scheme. All schemes shall be supported by an architectural statement explaining the factors considered in the design. A minimum of two schemes shall be provided, from which the purchaser shall select.

- vii) The architectural components shall be designed for the conditions at the plant site for the design life of 30 years unless specifically noted otherwise.

7.5.11.3 Exterior architecture

General design criteria for the exterior architectural systems shall be as follows. Quality plans and detailed specifications for all items to be incorporated in the works, shall be got approved by purchaser.

- i) Walls and cladding

The function of all exterior walls is to provide enclosures for buildings. The exterior enclosure protects the enclosed system and personnel from adverse weather conditions and allows for a controlled interior environment. The cladding of the main plant buildings shall consist of brickwork, walls upto a height of 10 metres from ground level. Metallic cladding with colour pre-coated galvanized metallic cladding sheets shall be provided above 10 m level up to roof level. Brick work shall be provided with plastering on both faces and internal and external painting.

- ii) Brickwork

The exterior brickwork walls shall consist of load bearing and non-load bearing type construction. For walls heights exceeding 3.0 m required reinforcement shall be provided to meet the applicable building codes and standards. Bricks of minimum 75 kg/cm² crushing strength shall be provided. Brick work shall be carried out in cement sand mortars 1:4 conforming to IS: 1077 or higher cement content. Cement sand mortar shall conform to IS: 2250.

- iii) Plastering

All exterior and interior brick work walls shall be provided with plaster on both faces. 12 mm and 19 mm thick plaster shall be provided on the even and rough faces respectively. Minimum cement sand mix of 1:5 shall be used for plaster. Plastering shall conform to IS: 1661. Ceiling plaster shall be 6 mm thick with cement sand mix of 1:3.

- iv) Metal wall cladding

Double skin insulated cladding made of 0.5 mm thick silicon polyester colour pre-coated high tensile steel sheets shall be provided for wall cladding above 10m height up to roof level for main plant building. The outer and inner skin shall be of profile sheet of depth 28 mm. Cold rolled steel of 550 MPa yield stress conforming to ASTM A 446 grade E with hot-dip metallic coating of Al-Zn alloy shall be used

as substrate. Metallic coating thickness shall be minimum 150 gms/m² total. The surface shall be colour-coated by oven-baked paint system applied over substrate.

v) Insulation

The insulation shall be of resin bonded mineral wool of density 48 kg/m³ and thickness 50 mm minimum.

Insulation materials shall be added to walls where necessary to reduce cooling loads. Also, insulation shall be used for sound absorption on walls which enclose equipment that has been determined as generating excessive noise. This sound insulation shall be provided in interior concrete block, sound block, or insulated metal wall panel liners as appropriate. The liner panels shall be as described above, except they shall include perforations and insulation enclosed in plastic bags. The overall noise reduction coefficient shall be 0.80 or better.

vi) Windows and ventilators

- a) Window and ventilator frames shall be made of extruded aluminum, steel, or other tried and proven material which is resistant to the corrosive environment. Frames shall have a minimum depth of 38 mm and a minimum thickness of 3 mm. Ventilation sections shall be compatible with the frames providing a weather-tight seal.
- b) All steel, windows and ventilators shall conform to IS: 1361.
- c) All aluminum doors, windows shall be made of extruded aluminum sections of heavy gauge, minimum 3 mm thickness.
- d) Glazing of windows shall be done with 4 mm thick float glass of best quality for windows located in ground floor and at accessible floors.
- e) Glazing of windows and ventilators located at higher elevations where frequent replacement is not feasible, shall be done with 6 mm thick wired glass conforming to IS: 5437.
- f) All windows shall be glazed and fully flashed and sealed for weather-tightness. The entire building enclosure shall be completely weather-tight and air tight. All window hardware shall be substantially made, smoothly finished, accurately fitted and smooth in operation.
- g) Windows shall close tightly without binding. Operators shall operate freely and smoothly, adjusted to close tolerances for positive closing of windows with a minimum of play in operator linkages.
- h) All ground floor windows shall be lockable and shall be provided with security grills.



vii) Louvers

Ventilation openings shall be provided with drainable formed gutter type storm-proof blade louvers complete with bird screens. Operating damper blades shall be provided behind the fixed louvers to allow closing of the openings. On long expanses of louvers, a continuous blade concealed support system shall be provided. Louvers shall be fabricated from extruded aluminum, steel, or other tried and proven material which is resistant to the corrosive environment and shall be provided with a poly-vinylidene fluoride finish.

viii) Personnel doors

- a) Personnel doors shall be the hollow metal type, flush, 45 mm thick, insulated, with formed hollow metal frames. The doors shall be constructed from 1.3 mm steel sheets with an internally reinforced, insulated core. Frames shall be constructed of 1.6 mm steel, with all joints mitered, welded, and ground smooth. Both doors and frames shall be factory galvanized, primed and field painted. In areas of the plant where excessive negative pressure hinders normal door operation, special balanced door hardware shall be provided.
- b) All steel doors and frames shall conform to IS: 1038 and IS: 4351.
- c) All aluminum doors shall be heavy gauge minimum 3 mm thickness of best quality and workmanship of 'INDAL' make or equivalent.
- d) Glazing of fully glazed doors and partitions shall be done with 5.5 mm thick float glass of best quality.
- e) Doors shall have a glazed vision panel when required by door function. Glazing shall consist of tempered safety glass or wired glass.
- f) Doors located on the ground floor of buildings shall swing out. Doors at other levels shall swing in or as required to meet egress requirements. Heavy-duty hardware shall be used. All outside doors shall be provided with door closers. Locks shall be provided on interior and exterior doors as required by the purchaser.
- g) Fire doors shall conform to hollow metal door requirements and shall be provided with fillers adequate to meet the required fire rating. The door, frame, and hardware shall bear a certification label for the class of opening and rating. Doors for fire exits shall be secured with panic bars. Fire doors shall conform to IS: 3614 (part I and II).

ix) Equipment access doors

Large access exterior doors shall be vertical lift type rolling shutters, with weather seals and windlocks. Components shall be formed from galvanized steel, factory primed, and field painted. Doors at high traffic areas shall be motor-operated. Doors

shall be manually operated where access is infrequent. Rolling shutters shall conform to IS: 6248.

x) Roofs

a) Metallic roofing

Turbo-generator bay of main plant building shall be provided with metallic roofing. This shall comprise of factory pre-fabricated sandwich panels comprising of an outer skin of permanently colour coated profile sheet of depth 28 mm, 0.5 mm thick high tensile steel 550 MPa yield strength conforming to ASTM A-446 Grade 'E' with hot dipped metallic coating of aluminium zinc alloy of coating thickness minimum 150 gsm/m² as per AS 1397. The colour coating shall comprise of a top coat of approved shade of Silicon Polyester/ XRW of 20 microns thickness over a primer coat on the exposed side and a neutral back coat over a primer coat over galvanised steel on the back side.

The inner sheet shall comprise of a plain permanently colour coated steel sheet of 0.5 mm thick (coating and colour specifications as of outer sheet) and having a high tensile CFC free close cell polyurethane foam insulation of density 40-45 kg/m³ average thickness 30 mm sandwiched in between. The K value of polyurethane foam shall be 0.023 W/mk. The sandwich panels shall be supplied in a single piece to the site.

The sheeting shall be supplied and installed with required matching accessories, fasteners and fixtures to give a complete leak-proof, water-proof system. The roof system shall have a minimum slope of 7⁰. All flashing, cappings of ridges, covers, louvers, and openings shall be formed out of same sheeting.

b) RCC roof

RCC roof shall be provided over control rooms and electrical switchgear rooms. RCC roof slab shall be of adequate thickness and laid to proper slope for easy drainage of rain water. Rain water pipes shall be fitted at designated locations. Suitable parapets and handrails shall be provided. For proper access, stairs shall be provided.

The RCC roof slab shall be provided with membrane water proofing treatment with two component coating or equivalent.

xi) Raised floors

Where indicated on the technical drawings, the contractor shall furnish and erect removable modular panels conforming to the following requirements:-



a) Material

Composite panels made of high density (675 kg/m^3) waterproof chipboard and aluminum sheets for protection of the interior face. The panel edges shall be slightly chamfered (5°) and protected by an aluminum profile or other conductive material.

Topping shall be made of high pressure laminate 1.3 mm thick.

b) Size of the panels

Nominal size shall be 600 x 600 mm.

Tolerance : 0.2 mm width and length
0.3 mm diagonal
0.2 mm thickness

Minimum thickness of the panels 40 mm.

c) Loading (except if noted otherwise in the execution drawings)

30 kN/m^2 : The maximum allowed deformation shall be 2 mm under 5 kN point load.

Minimum height of the free space between sub-floor and raised floor surface for control rooms shall be 1.0 metre.

d) Substructure

The substructure shall consist of adjustable pedestals and stringers. The pedestals are to be fixed by bolts to the concrete base slab floor. The stringers are bolted to the pedestal so that large cut-outs are possible.

The whole system shall be constructed in such a way as to allow conductivity of electrostatic charges and shall be connected to the earthing system.

Penetrations for cables and pipes shall be arranged.

For allowing an elastic connection to abutting walls, a peripheral joint of 3 mm width shall be arranged and sealed with an appropriate neoprene sealant.

7.5.11.4 Interior architecture

Interior architectural systems shall conform to the following general design criteria. Fire rated architectural systems shall be provided when required by building or fire codes. All normally occupied areas shall be finished areas.



i) Partitions

Interior walls shall be constructed of masonry, stud framing with gypsum board, metal wall panel, and factory finished assembled demountable type partitions.

Interior walls shall be constructed of concrete block/brick masonry, structurally designed and reinforced where other interior walls shall not provide durability. Plaster finish shall be applied to brick masonry walls followed by paint in approved colour.

ii) Windows

The fixed interior windows shall be framed with formed steel frames, aluminum, or other tried and proven material similar to those of personnel doors, with metal glazing stops. Frames in stud walls shall be the wraparound style. Frames for windows between the control room and the turbine area shall consist of fully glazed anodized aluminum storefront system.

Interior glazing shall consist of clear, polished plate, float, or tempered safety glass. Borrowed light fixed glass panels shall be used at corridor and interior work spaces.

iii) Personnel doors

a) Wood doors used in finished office areas shall be 45 mm thick full flush, solid core, veneer faced. All wood doors shall be morticed and reinforced at the factory.

b) Interior doors shall have a glazed vision panel as required. Glazing for the vision panel shall be tempered safety glass or wired glass.

c) Standard-duty hardware shall be used. Doors shall be provided with approved fittings, such as hinges, mortice locks of approved make, oxidized lower bolts and handles, door stops, and hydraulic door closers.

d) Where fire doors are required, the door, frame, and hardware shall bear a certification label for the class of opening and rating.

iv) Ceilings

a. False ceiling shall be provided for all air-conditioned areas and other areas where required from functional requirement.

b) Ceilings in unfinished areas shall leave the overhead structural frame exposed. The exposed structure shall be painted in unfinished areas. Sound control shall be provided.

c) Ceilings in finished areas shall generally consist of a suspended, exposed grid, lay-in acoustical type. The ceiling shall not sag when exposed to high local

humidity. False ceiling wherever envisaged shall be of aluminum alloy. Scope of work for false ceiling comprises of the supply and installation of TRAC 84C or equivalent approved by the purchaser, ceiling system comprising of 84 mm wide and 12.5 mm deep panels, roll-formed out of 0.5 mm thick aluminium alloy AA 3005 – 131 mm wide strip. The panel shall be coil coated stove enamelled with 20 micron DFT and of approved standard shades and colours. The panel shall be fixed on to roll-formed panel carriers of size 32 mm wide and 39 mm deep out of 0.60 mm thick black coated GI strip with cutouts to hold panels in a module of 100 mm at maximum 1.6 metre centre to centre. Carriers shall be suspended from roof/ truss by 4 mm diameter galvanized steel wire rod hangers with special height adjustment springs out of galvanized spring steel at maximum 1.3 metre centre to centre. Hangers shall be fixed to roof by “J” hooks and nylon inserts or to truss members by regular industrial grade GI wire. The panel length shall be maximum five (5) metre.

v) Grade floor

Reinforced concrete grade floor shall be provided at ground level in the power plant area comprising of the area from transformer yard, to boiler area upto chimney. The grade floor shall be in grade M20 concrete of minimum thickness of 200 mm, laid over PCC and compacted crushed stone base of 230 mm thickness. Grade slab shall be provided with reinforcement both ways, top and bottom with minimum 8 mm diameter tor steel at 200 mm c/s (minimum).

vi) Floor coverings

- a) Floor coverings on the main plant building turbine operating floor shall be granite tiles minimum 20mm thick laid over concrete. All other high traffic areas shall have either heavy-duty steel crete tiles or approved equivalent.
- b) For high moisture areas of locker rooms, showers, and toilets, an unglazed non-slip surface shall be used.
- c) Office areas and control room shall have heavy-duty antistatic PVC tiles and in- situ terrazzo.
- d) Steel troweled surface hardened concrete shall be used in all other unfinished areas in buildings throughout the plant site.

vii) Tiling materials

Tiling materials shall cover the following:-

- Tiles
- Ceramic tiles
- Terrazzo materials
- Acid proof tiles

Requirements to be met are as follows:-

a) Tiles

Tiles shall be sharp, straight, parallel, non-crumbling edges, free from soluble salt and other detrimental constituents; free from cracks and blisters; rear and side surfaces capable of bonding effectively for placing, laying and jointing.

All tiles shall be of first class quality. These shall be of uniform size and even surface, free from warps, laminations, serrated edges, chipped corners and other imperfections or flaws affecting their quality, appearance and strength.

b) Ceramic floor and wall tiles

Glazed and/or unglazed ceramic tiles shall comply with the following requirements and properties:

The tiles shall bear the identification mark of the manufacturer on the lower face in either positive or negative embossment. These shall be of approved make.

These shall be made from fine-grained vitrified sandstone ceramics of the highest quality. The dimensions of the slabs shall be regular and constant, the upper surface plane, smooth and flawless without a trace of fissures or blotches. The sides shall be perfectly straight and the corners perfectly rectified. The shade and hue of the colouring shall be uniform.

The tiles shall give a clear and sound under a hammer stroke. These shall be non-porous, abrasion-resistant (2.5 mm after 3000 hours) flexion and shock resistant (250 g/m²).

Acid (hydrochloric, nitric and sulphuric acid) attacks shall be less than 2.5% of their weight and their water absorbing capacity shall not be in excess of 1.5% of their dry weight.

Colour of the tiles shall be selected by the purchaser.

c) Terrazzo materials

Terrazzo floors or tiles shall be 20 mm thk and shall be of marble chips, granulite or gravel aggregates and be of size, colours and kind as selected by the purchaser.

Non-slip aggregates consisting of aluminium oxide or other approved rust-proof abrasive material not affected by cleaning compounds shall be utilized in all terrazzo work.

Portland cement shall be white or grey as required by the colour scheme selected for the terrazzo materials.

The cement shall conform to the requirement specified under clause “Concrete Works” hereabove.

d) Acid-proof tiling material

Acid-proof tiles shall be of ceramic unglazed vitreous tiles 20 mm thick as per IS: 4457, mortar conforming to IS: 4832 (part I). The tiles shall be scored or dovetailed at the back for improving the bonding properties and to give a good key.

The tiles shall be jointed with synthetic resin cement such as indicated below:

Polyester resin

Phenolic resin

Furanic resin.

Execution of tile work

All materials and structural components shall be processed in accordance with manufacturer’s instructions.

Prior to the start of his operations under this division, the contractor shall verify that all conditions are suitable for the timely and effective performance of his work. Where unsuitable conditions are found, they shall be reported in writing to the Purchaser and under the purchaser’s direction immediately corrected.

Work shall be carefully laid out to ensure symmetry about centerlines of the area involved and to obviate the use of less than half pieces of tiles, slabs, etc.

The work shall be executed with the highest degree of precision and according to the drawings and specifications.

- Preparation of surface

Before wall surfaces are covered with tiles, flags or mosaic to be set in normal mortar bedding, a sprayed coating of cement mortar shall be applied to the base unless otherwise specified.

Where no adequately even surface is available for work involving thin beddings, special provisions shall be made to compensate for this e.g. rendering coat, screed.



The concrete surface to which tiles, flags, terrazzo, screed, etc are to be placed, shall be cleaned by wet sandblasting and washed with water under pressure, so as to produce the specified surface condition.

viii) Wall coverings

- a) Wall coverings shall be used to enhance the appearance, cleanliness, and wall protection, where appropriate, particularly in lobby and office areas. All wall coverings shall provide a non-absorbing surface.
- b) A glazed surface over concrete block shall be used in locker and shower areas to maintain a sanitary and easily maintained wall. Vinyl wall coverings or ceramic/granite tiles shall be applied to give a finished appearance in entrance lobbies and office areas.
- c) Where specific wall coverings are not desired for the above applications, all finished area walls shall be painted.

ix) Sanitary facilities

- a) Toilet and shower facilities shall be provided for personnel in finished areas of all major buildings and in other areas as determined by project requirements.
- b) Sanitary facilities fixture types shall be selected by the purchaser to provide a balance of local and western fixtures. Towel and waste receptacles shall be recessed to the extent possible.
- c) Septic tank with soak away shall be provided for all toilets.
- d) Janitor closets and cleaning material storage areas shall be provided in finished areas of all major buildings.

x) Plinth protection

All buildings shall be provided with 1000 mm wide and 100 mm thick plain cement concrete paving around the outside. Plinth protection shall be laid over prepared subgrade and base formed with broken brick bats or rubble laid to a thickness of 150 mm.

xi) Furniture

All rooms shall be furnished for their intended use. The contractor shall provide the purchaser with a choice of furniture range.



7.5.12 Site

7.5.12.1 Grading and drainage

- i) The site grading and drainage system shall be designed to comply with all applicable state regulations. Topographic modifications to the site area are required to provide positive overall drainage.
- ii) Surface drainage onsite shall consist of overland and open channel flow. Drainage through a catch basin and underground pipe system shall be provided in some areas to avoid having trenches within that area.
- iii) Roads crossing over trenches shall be constructed with reinforced concrete box culverts to pass the design flow. Loading conditions as per IRC class A. Wheel and crawler loads shall be applied as necessary during design.
- iv) Site drainage facilities shall be designed for the flow resulting from a 1 in 50 year frequency rainfall event.
- v) All buildings and paved areas shall be provided with garland drains leading to the nearest main drainage.
- vi) The main plant complex area shall be graded with moderate slopes (1 percent minimum preferred) for effective drainage.

7.5.12.2 Roads

- i) Access within the plant site shall be provided by a system of roadways.
- ii) Roads shall be three types: Type I, Type II and Type III.
- iii) Type I roads shall consist of one 10.0 m wide asphalt paved carriageways with 1.5 m wide hard shoulders. The main plant access road and a portion of the main plant complex circumferential road shall be Type I.
- iv) Type II roads shall be 4.5 m wide with 1.5 m wide hard shoulders on either side. Type III roads shall be provided along the plant boundary for access for security and maintenance.
- v) All roads shall be surfaced with gravel during the construction period. Occasional applications of a dust palliative material shall be used to minimize the dust problem during the dry seasons.
- vi) All Type I and Type II roads shall have a minimum turning radius of 15.2 m. Bollards shall be provided along side all type roadways near equipment which requires protection. Spare duct banks shall be provided under all type roads spaced at 100 m intervals.



- vii) Signs shall be provided for vehicle management and shall meet Indian standards. All signs shall be dual worded in both English and the local Indian language.

7.5.13 Pile Foundations

7.5.13.1 The pile foundation shall be of cast-in-situ bored piles as per IS: 2911 or approved international standard (relevant part). Three stage flushing of pile bore shall be ensured by air lift technique or any internationally accepted method duly approved by purchaser. The construction methodology to be adopted shall be suitable to ensure proper termination of pile in the strata and to ensure pile bore free from spoils.

- i) Only RCC piles shall be provided.
- ii) Minimum diameter of piles generally shall be 450 mm. The allowable load carrying capacity of the pile in vertical compression shall be limited to its structural capacity. The uplift and lateral load capacities shall be restricted to 20% and 5% respectively of the allowable load capacity in vertical compression. However, the pile capacities to be adopted shall be the least of the estimated design values and that obtained from the pile load tests. Maximum permissible lateral deflection at pile head shall be 5.0 mm.
- iii) Only straight piles shall be used.
- iv) The piling work shall be carried out in accordance with the provisions of IS: 2911 (relevant part) or approved International Standard and approved construction methodology.
- v) The actual length of pile shall in no case be less than the design length. However, a minimum socketing length of 3 times the diameter of the pile for on shore shall be ensured in rock with USC not less than 50 kg/cm².
- vi) Regular QA checks for density of circulation mud, contaminated mud and samples from pile bore bottom, slump of concrete, unconfined compressive strength test on rock, pile concrete integrity etc. shall be done by the bidder.

7.5.13.2 Pile load tests

Bidder shall install the piles for initial load test. Number of initial load tests to be performed for each diameter and rated capacity of pile shall be as under:

- | | | |
|---------------------------|---|---|
| i) Vertical (compression) | - | 3 |
| ii) Lateral (horizontal) | - | 2 |
| iii) Uplift (tension) | - | 3 |

The initial pile test shall be conducted with test load upto three times the estimated pile capacity. In case of compression test, the method of loading shall be cyclic as per IS: 2911 (relevant part).



Safe load interpretation from pile load test shall be as per IS: 2911 (part-IV).

Routine pile load tests shall be performed for each diameter and allowable capacity of pile shall be as under:

Vertical : 0.5% of the total number of piles
provided subject to a minimum of one.

Lateral : 0.5% of the total number of piles
provided subject to a minimum of one.

The routine test on piles shall be conducted upto test load of one and half times the allowable pile capacity by direct loading method. Piles for routine load test shall be approved by the purchaser.

In case, routine pile load test shows that the pile has not achieved the desired capacity or pile(s) have been rejected due to any other reason, then contractor shall install additional pile(s) as required and accordingly, pile cap design should be reviewed and modified if required.

Wherever pile foundations are adopted, a minimum of three pile group shall be provided below every column/ foundation.

7.5.13.3 Other requirements

- i) Cement type : As approved by the purchaser based on soil water chemical environment.
- ii) Concrete grade : Minimum grade of concrete shall be M25 unless specified otherwise elsewhere concrete shall be dense and durable.
- iii) Reinforcement : As approved by purchaser based on soil type soil water chemical environment.
- iv) Cover to reinforcement : As per IS: 456, subject to minimum of 50 mm.



7.6 FINISHING SCHEDULE

7.6.1 General

This section covers the requirements for interior and exterior finishes.

7.6.2 Interior and Exterior Finishes

Interior and exterior finishing schedules are given in Table 1 and Table 2 respectively.

Table 1. Interior Finishing Schedule

Sl. No.	Description of Area	Flooring	Wall finish over cement plaster/ plaster of paris	Ceiling finish over cement plaster
1.	Operating/ maintenance areas of workshop, pump houses, compressor house, DG set, air washer building, AC equipment room, air handling room, mill and bunker building, transfer points.	Cement concrete with metallic hardener topping 40m thick.	Oil bound distemper.	White wash (except metal deck area)
2.	General storage areas	-do-	-do-	White wash
3.	Cable vault/ cable spreader	-do-	-do-	White wash
4.	Boiler area paving	-do-		
a)	Equipment/vehicle movement area	Non-metallic granular topping		
b)	Balance area	Cement concrete with metallic hardener topping 40mm thick		
5.	Main plant building			
a)	Ground floor	Cement concrete with metallic hardener topping	Oil bound distemper over plaster of paris	White wash
i)	railway track area and unloading bay			
ii)	Balance area including passage	Heavy duty cement concrete tiles	-do-	-do-
b)	Mezzanine floor (excluding grating area)	-do-	-do-	-do-



c)	Deaerator floor	Cement concrete with metallic hardener topping	-do-	-do-
d)	Operating floor	20mm (minimum) thick polished granite slab (1st quality)	Oil bound distemper over plaster of paris (except cladding area)	White wash (except metal deck area)
6.				
a)	MCC room	10 mm thick vitrified ceramic tiles (unpolished)	Oil bound distemper over plaster of paris	White wash
b)	Switchgear room	Cement concrete with Metallic hardener topping 40mm thick	-do-	-do-
7.				
a)	Control Room Area including control room computer room, control equipment room	10mm thick mirror polished vitrified ceramic tiles	Acrylic emulsion paint glazed partition with colour anodized aluminium framework	0.5mm thick pre coated (colour)/ aluminium lineal false ceiling in approved pattern.
b)	Conference room, senior executive room	10mm thick mirror polished vitrified ceramic tiles	i) Acrylic emulsion paint over plaster of Paris ii) Glazed partition with colour anodized aluminium framework	Combination of aluminium lineal false ceiling and gypsum plaster board.
c)	Record room	20mm thick polished Kota stone	Oil bound distemper over plaster of paris	Mineral fibre board
d)	Locker room	-do-	-do-	-do-
8.	Toilet area	i) 20mm thick polished Granite stone ii) 20mm thick polished granite in one piece for wash basin platform	20mm (min.) thick granite tiles upto 2.1 m and oil bound distemper over plaster of paris for balance height	White wash
9.	Pantry area and canteen	i) 20mm thick polished Granite tiles ii) 20mm thick polished Granite stone for platform	-do-	White wash



10.	Office room, staff room	10mm thick polished vitrified ceramic tiles	Acrylic emulsion paint over plaster of paris	Mineral fibre board with MS coated framework
11.	SWAS room	10mm thick mirror polished vitrified ceramic tiles	- do-	-do-
12.	Laboratory area	10mm thick dust pressed ceramic tiles	-do-	White wash
13.	RCC staircase	20mm thick polished Kota stone for riser and tread in combination with marble	Synthetic enamel paint upto 1.2m height	Oil bound distemper over plaster of paris on the underside of the staircase
14.	Entrance, lobbies and lift areas	20mm thick polished granite stone	i) Resin bounded granular textured finish ii) 20mm thick polished granite on lift facia	0.5mm thick oil coated, lineal aluminium false ceiling
15.	Passage and general circulation area	20mm thick polished Kota stone with marble stone border	Oil bound distemper over plaster of paris	Mineral fibre board false ceiling and white wash for non false ceiling area
16.	Battery room			
	i) For dead acid batteries	20mm thick acid resistant tiles over bitumen primer	20mm thick acid resistant tiles over bitumen primer over 1.2m height and chemical resistant epoxy paint for balance height	Chemical resistant epoxy paint
	ii) For Ni-Cd batteries	7mm thick anti-skid tiles Group-5	Oil bound distemper over plaster of paris	White wash
17.	Oil canal, oil room, oil purification tank and other areas where oil spillage is likely to occur	Oil resistant paint(epoxy based amine cured) 150 micron primer over CC flooring	Oil resistant paint up to 2.1 m height Oil bound distemper over plaster of paris for balance height	White wash except oil canal area



18.	Regeneration and other than areas requiring acid/alkali resistant treatment	Cement concrete with metallic hardener topping	Oil bound distemper over plaster of paris	White wash
19.	Covered parking area	Interlocking cement concrete blocks	Water proof cement paint	White wash
20.	Pathways including equipment installation area on top of roof	22mm thick concrete chequered tiles		

Note:

1. All wall and roof areas above false ceiling shall be plastered and white washed.
2. The colour and pattern of finish shall be as per approved details.
3. All material shall be of reputed and established brand approved by the purchaser.
4. Wherever alternative materials are specified, the final selection rests with purchaser.
5. The finishing schedule shall also be applicable to similar functional areas for all other buildings and facilities.
6. All the finishing materials shall be applied/ provided as per manufacturer specification and guidelines under the supervision and guidelines of manufacturer.
7. Requirement given above is suggestive and minimum. Bidder can suggest alternative scheme conforming to design and functional requirement subject to approval of the purchaser.

Table 2. Exterior Finishing Schedule

Sl. No.	Description of area	Walls and protections	Soffit of projections
1.	Main plant building	i) Initial height of 3m (nominal) permanent finish using brick cladding in cement mortar, plastered covered with single sheet of metal cladding. ii) Approved colour/colour combination of colour coated metal cladding for balance height.	Resin based textured paint Approved colour/ colour combination of colour coated metal cladding
2.	Buildings with concrete frame work	Resin bonded granular textured finish and resin based textured paint to match in harmony with the main plant, over plaster of Paris. Resin bonded granular textured finish.	Resin based textured paint
3.	Steel structures, trestles etc.	Specification as specified	
<p>Note:</p> <ol style="list-style-type: none"> The colour and pattern of finish shall be as finalized by purchaser. All materials shall be reputed and established brand approved by purchaser. All the finishing work shall be carried out as per manufacturer specification and approved colour. All the hand rails where ever required shall be of 320mm GI pipe except for main plant building, administrative building and service building wherein stain less steel railing of 50mm diameter shall be provided. During detailed engineering stage, purchaser may suggest some modifications, which shall be incorporated without any cost implications to purchaser. 			



STANDARD TECHNICAL SPECIFICATION FOR MAIN PLANT PACKAGE
SECTION- 8
(QUALITY ASSURANCE PLAN)

8.1 QUALITY ASSURANCE PROGRAMME

All materials, components and equipments covered under the scope of supply shall be procured, manufactured, erected and tested at all stages as per the comprehensive Quality Assurance (QA) programme. The QA document indicating the specific inspection and testing requirements to be followed shall be subject to the approval of the purchaser. The contractor shall submit his quality assurance programme for review by purchaser and shall generally cover the following:

- i) Organizational structure for management and implementation of the proposed quality assurance programme.
- ii) Quality system manual.
- iii) Documentation control system.
- iv) Qualification and experience data of contractor's key personnel.
- v) The procedure for procurement of materials, parts, components and equipment.
- vi) Procedure for inspection at source, inspection of incoming raw-materials/ parts/ components & verification of materials purchased.
- vii) Procedure for selection of sub-vendors and sub- contractors.
- viii) System for shop manufacturing including process controls, fabrication and assembly controls, and procedure for product identification & traceability.
- ix) System for inspection and testing during manufacture, processing, fabrication, welding, assembly and other activities.
- x) The reference documents, plant standards, acceptance norms, test and inspection procedure etc.
- xi) Control of calibration and testing of measuring and testing equipments.
- xii) System for quality audits, documentation to indicate conformance or non-conformance of the product to the specification and testing and inspection requirements; review and control of non- conforming items and system for corrective actions.



- xiii) System for indication and appraisal of inspection status.
- xiv) System for authorizing release of manufactured product to the purchaser.
- xv) System for packaging, handling, transportation, storage and delivery.
- xvi) System for generation and maintenance of inspection and test records.



8.2 STEAM GENERATOR AND AUXILIARIES

Testing and inspection requirements of major equipment over and above the respective code/standard requirements are given hereunder:

8.2.1 Pressure Parts

Only those materials shall be used in the manufacture of pressure parts which can be identified against mill sheet or manufacturer test certificates. Material shall meet all the mandatory requirements (and supplementary checks, if asked for) of specified specification, Indian Boiler Regulations (IBR), and relevant code/standard. All non destructive testing as detailed against relevant equipment shall meet the requirement of ASTM section 3 Vol. 3.03 or equivalent BIS standard.

8.2.1.1 Drum

- i) Each plate shall be subjected to a 100 % normal and shear ultrasonic at the mill to meet the minimum requirements of BS: 5996 grade LC3/ ASTM or equivalent standards. Elevated temperature tensile tests shall also be carried out on plate material for each heat.
- ii) After cutting to size and removal of cut outs, the plates shall be subjected to magnetic particle examination (MPE) along the edges of the plate and on areas adjacent to the cutouts.
- iii) All forged connections shall be examined by 100% ultrasonic testing (UT) before machining.
- iv) Fully machined connecting pieces of internal diameter 100mm and above, except for forgings, shall be subjected to MPE.
- v) Mechanical tests shall be carried out on specimens prepared from the production control test plates of the longitudinal welds.
- vi) Mechanical tests shall be conducted on the specimens from manhole cutouts of dished ends.
- vii) All butt welds shall be subjected to 100% radiographic test (RT) before stress relieving.
- viii) On completion of welding, the entire drum shall be subjected to stress relieving in the furnace.
- ix) All butt welds shall be subjected to 100% ultrasonic test and magnetic particle examination after stress relieving.
- x) All full penetration welds shall be subjected to ultrasonic examination after stress relief.



- xi) After stress relieving, all welds shall be examined by magnetic particle examination (MPE) methods depending on size and accessibility.
- xii) Complete drum shall be subjected to hydraulic pressure test and all compensating pads shall be pneumatically tested.

8.2.1.2 Headers

- i) Raw material for headers shall be subjected to UT prior to fabrication.
- ii) All butt welds shall be subjected to MPE and radiographic examination before stress relieving.
- iii) All full penetration nozzle and attachment welds shall be subjected to UT prior to stress relieving.
- iv) All nozzles, branches, stubs and load bearing attachment shall be examined by MPE techniques after the toes of the weld have been ground smooth and stress relieved.
- v) Non-load bearing welds shall be examined by MPE techniques after the toes of the welds have been ground smooth and stress relieved.
- vi) Completed closed end headers shall be subjected to hydraulic pressure tests and all compensating pads shall be pneumatically tested.

8.2.1.3 Tubes and tube elements

- i) Raw material for tubes for water wall, superheater, reheater, economiser, riser, supply and connecting tubes including nozzle/stubs, connections for drum, headers, pipe work etc., shall be subjected to 100% UT prior to fabrication as per IBR or ASME E 213 or equivalent with the longitudinal calibration notch of depth 5% of wall thickness (0.3mm minimum and 1.5mm maximum).
- ii) All bent tubes, stubs shall be checked for ovality and thinning by ultrasonic method on first off lot and random checks on subsequent pieces.
- iii) All tubes, stubs, panels, coils shall be checked for clearance by steel ball test and for cleanliness by sponge passage.
- iv) Finished butt welds shall be subjected to RT and UT. Wherever the code/standard/process specifies random sampling, the same shall be minimum 20%. All fillet welds shall be subjected to MPE or dye penetration test (DPT).
- v) Tubes and fabricated panels, coils shall be subjected to hydraulic pressure test excluding water wall panels and loose tubes but including burner panels, reheaters, superheaters and economizers.



8.2.1.4 Integral piping, valves and fittings

- i) All pipe lengths shall be subjected to 100 % ultrasonic examination as per ASME E213 or equivalent, with longitudinal calibration notch of depth 5% of wall thickness (0.3mm minimum and 1.5mm maximum) or hydraulic tests and UT or RT on longitudinal welds at the tube mill.
- ii) All mother pipes shall be subjected to 100% UT prior to fabrication as per ASME E 213 or equivalent with longitudinal calibration notch of depth 5% of wall thickness (0.3mm minimum and 1.5mm maximum).
- iii) All forged fittings shall be checked by UT and formed fittings shall be checked by MPE.
- iv) All pressure parts shall be 100 % UT tested. All welded, cast alloy steel and carbon steel fittings for use above 71 bar design conditions shall be 100 % RT tested. However, wherever the code/standard/process specifies random sampling, the same shall be minimum 20%.
- v) All bent pipes shall be checked for ovality and thinning by UT on first off lot and on random samples for subsequent pieces. Outer surface of bends shall be subjected to MPE or DPT.
- vi) The edge preparation for shop and site welds in stainless steel and alloy steel shall be subjected to dye penetration check. Non-destructive examination of welds shall be carried out after post weld heat treatment, if any.
- vii) All butt welds shall be subjected to UT or RT and MPE. For weld on alloy steel piping, UT or RT shall be done after stress relieving. Wherever the code/standard/ process specifies random sampling, the same shall be minimum 20 %.
- viii) All butt welds in alloy steel piping of P91, X20 and X 22 shall be checked for RT or UT and MPE after stress relieving (SR). UT shall be of digital recordable type.
- ix) All weld joints in alloy steel piping of P 91, X20 and X22 shall be checked for hardness. For preheating and post weld heat treatment (PWHT) induction heating shall be deployed. However, PWHT can be done in furnace also. 3% hardness check shall be carried out on welds of other alloy steel piping.
- x) All load-bearing attachment welds shall be subjected to MPE after stress relieving.
- xi) For HP piping, non-destructive examination of welds shall be carried out in accordance with the relevant design/manufacturing codes. However, apart from above, the following requirements shall be met. Further statutory requirement, wherever applicable shall also be complied with the following:



- a) Temperature $> 400^{\circ}\text{C}$ and/ or pressure exceeding 71 bar
 - 100% RT or UT on butt welds and full penetration branch welds.
 - 100% MPE.
- b) Temperature $> 175^{\circ}\text{C}$ upto 400°C and/or pressure exceeding 17 bar and upto 71 bar
 - 100% RT or UT on butt welds and full penetration branch welds for pipe diameter more than 100NB.
 - 10% RT or UT on butt welds and full penetration branch welds for pipe diameter upto 100NB.
 - 100% MPE.
- c) All other pipes not covered above shall be subjected to 100% MPE or DPT in case of under ground pipes and 10% MPE or DPT in case of piping above the ground. Further, 10% of butt welds of underground piping shall be subjected to RT.

8.2.1.5 Valves

- i) Pressure retaining parts of valves shall be subjected to NDT as per Table 8-1.
- ii) Hardened and stellitted valve disc and seat shall be subjected to DPT and hardness check.
- iii) Color matching of valve disc/plug and seat shall be carried out to ensure minimum 80% contact and no through passage.
- iv) Hydraulic pressure test and seat leak test shall be carried out as per ANSI 16.34 or IBR.
- v) Air seat leak test shall be carried out as per applicable standards or codes.
- vi) Functional tests shall be carried out on each valve to check the following as per the approved valve data sheet
 - a) Smooth operation.
 - b) Valve travel, closing and opening time.
 - c) Current drawn by actuators.
- vii) Springs for safety valves shall be tested with suitable NDT and for spring stiffness rate.
- viii) Safety relief valves shall be tested for performance.



Table 8-1, NDT requirements for pressure retaining components of valves

Valve size NB in mm	ANSI Class upto 300	ANSI Class above 300 upto 600	ANSI Class above 600 below 900	ANSI Class 900 and above but below 4500
Less than 50	Visual	Visual	Visual	MPE (for special class valves)
50 & above but below 100	Visual	Visual	MPE (for special class valves)	MPE and RT on 10% of valves on 100% area
100 & above but less than 300	Visual	MPE	MPE and RT on 10% of valves on change of section and weld ends	MPE and RT on 100% area
300 and above	MPE	MPE	MPE and RT on change of sections and weld ends	MPE and RT on 100% area

Note:

- a) For body and bonnet forgings, UT with MPE may be adopted in place of RT.
- b) For austenitic steel, MPE may be replaced by DPT.

8.2.1.6 Non pressure bearing attachments

Load bearing welds shall be subjected to UT and MPE after stress relieving. Non load bearing welds shall be subjected to MPE after stress relief. The toes of the welds adjoining the drum shall be ground smooth prior to stress relieving before carrying out this examination.

8.2.1.7 Hydraulic test

- i) The drum and all components which are to be subjected to fluid pressure shall be tested to minimum of 150% of the design pressure. The duration of the pressure tests shall be sufficient, as approved by the purchaser, to show any leakage paths and to permit a thorough examination of the component whilst under pressure.
- ii) The temperature of the fluid used for the pressure test shall be such as to avoid any possibility of brittle fracture at a low temperature and the same shall be modified and submitted to the purchaser for approval, before commencing the test.
- iii) The fluid used shall be of a sufficient purity and where relevant, suitable inhibitors shall be used to avoid excessive corrosion and /or damage to temporary parts either during the test or prior to drying and cleaning.



8.2.1.8 Pneumatic test of compensating pads

All compensating pads shall be provided with two-threaded weep holes to test welds at 0.5 kg/cm² (g) with soap solution and no leakage shall be ensured.

8.2.2 Boiler water circulation pumps

- i) Raw material for casing, shaft and impeller shall be checked for high temperature physical properties, apart from mandatory and supplementary check of material specification.
- ii) All forging and castings shall be subjected to 100% UT or RT and MPE or DPT check.
- iii) Static and dynamic balancing of the rotary parts shall be carried out.
- iv) Hydraulic pressure test shall be conducted on pump casing at minimum 1.5 times the design pressure.
- v) Each pump shall be subjected to performance test at the manufacturer's works under as near actual site conditions as possible.
- vi) Following test shall be carried out on assembled units: -
 - A) Type test:
 - a) NPSH test
 - b) Temperature rises test.
 - c) Under voltage test.
 - d) Quality assurance proof test.
 - e) Tests to establish unit functioning of pump at operating temperature and pressure.
 - f) Hot standstill and start up tests.

Note :- Type test if already done on the same model will not be repeated. Documents will be submitted for review and approval of the purchaser.

- B) Routine test:
 - a) Hydrostatic test of complete unit.
 - b) Overspeed test.
 - c) Tests to determine unit characteristics.
 - d) Pump performance.
 - e) Unit run at rated voltage.
 - f) Starting current at rated voltage.
 - g) Cold start up test.



- h) Endurance test of motor windings, joints and terminal seals
 - i) Noise level.
 - j) Inspection of dismantled unit.
 - k) High voltage test.
- vii) For heat exchanger for these pumps, butt welds on pressure parts shall be tested with RT or UT and all other welds shall be tested with MPE or DPT.
- viii) Hydraulic test shall be carried out both on tube side as well as shell side at minimum 1.5 times the design pressure.

8.2.3 Air Preheaters, Steam Coil Air Pre-Heater and Fuel Oil Heaters

8.2.3.1 Air Preheaters

- i) Forged shafts for air preheater like stub shaft, main rotor forging, housing hub shall be subjected to 100% UT at mill and magnetic particle examination after machining.
- ii) For non-modular design, trial assembly shall be carried out at shop prior to despatch to site.
- iii) Critical welds of rotor post shall be subjected to radiographic examination.

8.2.3.2 Steam coil air pre-heater and fuel oil heaters

Hydraulic pressure test shall be carried out on the heating coils. All pipes, valves, steam traps and mountings shall be subjected to hydraulic test as called for under IBR, BS or other approved codes.

8.2.4 Soot Blowers

- i) Butt weld between nozzle and lance tube shall be subjected to 100 % radiography tests.
- ii) Soot blower shall be subjected to operational checks as below:
 - a) Smooth operation
 - b) Long tube travel, closing and opening time.
 - c) Current drawn.

8.2.5 ID, FD and PA fans

- i) Rotor components shall be subjected to ultrasonic test at mill and magnetic particle examination/dye penetration examination after rough machining.



- ii) Butt welds in rotor components shall be subjected to 100% UT and all welds shall be subjected to MPE or DPT after stress relieving.
- iii) All rotating components of fans shall be dynamically balanced to quality grade 2.5 of ISO 1940.
- iv) Test for natural frequency of all fan components, including fan blades shall be carried out for the fans.
- v) Full range performance test shall be carried out on one fan of each type and size as per BS 848, Part-1.
- vi) Hydraulic coupling of ID fan shall be checked for string test i.e., operational check of one fan assembly using hydraulic coupling to check temperature rise, smooth operation, vibration and noise level. Dry run test shall preferably be carried out during string test.

8.2.6 Coal Mills, Pulverised Coal Piping and Burners

- i) Raw material for shaft, coupling, gears and pinions, top and bottom races and other rotating components shall be subjected to UT. MPE or DPT shall be carried out to check surface soundness.
- ii) Wear-resistant parts shall be subjected to UT or RT to check soundness after suitable heat treatment. Check for chemical composition and hardness shall be carried out. For ceramic materials check for various properties including hardness, density, wear rate and composition shall be carried out.
- iii) Butt welds in the body casing and separator of the mill shall be tested by RT and MPE. All other welds shall be tested by MPE or DPT for acceptance.
- iv) All gearboxes shall be run tested for adequate duration to check rise in oil temperature, noise level and vibration. Check for leak tightness of gear case also shall be performed.
- v) Fabricated pipe welds shall be examined by MPE.
- vi) Ceramic/basalt lined piping and bends etc. shall be checked for proper layout.
- vii) Weldments on burner components shall be checked with suitable NDT. The burner assemblies shall be tested for operation at shop.
- viii) All rotating components of fans shall be dynamically balanced.

8.2.7 Coal Feeders

- i) All welds in the casing and pulley fabrication shall be checked with MPE.



- ii) Type tests including degree of protection and routine tests shall be done as per relevant Indian Standards or equivalent International Standards.
- iii) All major items like plates for casings, head pulley, tail pulley, pulley shaft and major castings shall be procured with respective material test certificates.
- iv) Explosion proof test at 50 psi as per NFPA code shall be done as type test. Leak tightness test shall be done on individual feeder casing. Endurance test for load cell shall be carried out.
- v) Test for weighing accuracy, calibration and repeatability shall be carried out at various speeds by coal flow on one feeder.
- vi) Calibration check shall be carried out on all feeder cabinet and assemblies prior to dispatch.

8.2.8 Boiler structure, ducts, hoppers, dampers etc.

- i) Only those materials which have been identified against mill sheet or test certificates shall be used for construction. Structural steel and built up plate girders for main boiler shall be fully killed fine grained and normalised. All plates of tension and compression flanges and connection material and plates above 40mm thickness shall be 100% ultrasonically tested.
- ii) Visual inspection of all welds shall be performed in accordance with AWS D.1.1. Also the butt and fillet welds for built up plate girders shall be inspected 100% by magnetic particle examination.
- iii) RT or UT shall be performed on all butt welds of thickness 32mm and above. For thickness below 32mm and upto 25mm, 100% MPE shall be carried out and for thickness below 25mm 10% MPE or DPT shall be performed. Edge preparations for field welding shall be examined by MPE for plate thickness 32mm and above. Field welds ends in ceiling girder shall be subjected to Ultrasonic examination for 100mm depth from the edges.
- iv) Ceiling girders, columns, ducts hoppers and tunnels shall be trial assembled and match marked prior to dispatch/erection. At least two consecutive girders alongwith cross member shall be assembled at a time.
- v) Drum sling rods
 - a) Sling rods forging shall be subjected to ultrasonic examination.
 - b) Welds shall be examined by UT and MPE after stress relief.
 - c) Trial fitment of the rods with the drum shell shall be carried out to ensure proper contact.



- d) Screw thread of the rods shall be suitably protected to avoid damage during handling and transport.
- vi) Dampers
 - a) All the dampers shall be subjected to operational test/checks.
 - b) Gas tight dampers shall be subjected to shop leakage test to demonstrate the guaranteed tightness (minimum one damper of each type and size offered). In case such type test is already done, the reports of the same shall be submitted for review.
 - c) All dampers shall be checked for sealing dimensions to establish guaranteed tightness.

8.2.9 Electro- Static Precipitators (ESPs)

8.2.9.1 Discharge and collecting electrodes

- i) Work tests for discharge electrodes shall include the following (for the wire type electrodes):
 - a) Chemical and tensile tests.
 - b) Metallographic examination-longitudinal and transverse (250X)
 - c) Surface finish and surface purity from chloride ions.
 - d) Spring back and surface finish after coiling (applicable to helical discharge electrodes)
- ii) Work tests for collecting electrodes and rigid discharges electrode shall include the following:
 - a) Chemical and mechanical properties.
 - b) Check for profile and straightness.
 - c) Check for surface finish and dimensional accuracy.
 - d) Cupping test for deep drawn sheets.

8.9.2.2 ESP structure

- i) Visual inspection of all welds shall be performed in accordance with AWS D1.1.
- ii) Also the butt and fillet welds for built up plates and columns shall be inspected by 100% MPI.



- iii) Radiographic examination shall be performed on butt welds as per AWS D1.1. 100% radiography on tension flange (bottom flange) welds and spot radiography on all joints in compression flange (top flange) of all beams and columns shall be carried out. The minimum length of welds for spot radiography and acceptance criterion shall be as per AWS D 1.1.
- iv) Edge preparation for field welding shall be examined by MPI.



8.3 STEAM TURBINE GENERATOR AND AUXILIARIES

Testing and inspection requirement of major equipment over and above the requirements of respective codes/standards are given hereunder:

8.3.1 Steam Turbine

8.3.1.1 High pressure (HP) and intermediate pressure (IP) enclosures

The following shall be applicable to high pressure cast steel enclosures (for example high pressure and intermediate pressure inner and outer cylinders, steam chests and liners, steam inlet pipes, nozzle boxes):

- i) Test pieces fully representative of the material and condition of the casting shall be provided to the purchaser to enable the determination of the properties of material to be used. Casting suppliers should have established practices to ensure requirements of creep and rupture for long exposure of the component/equipment to high temperatures and pressures. In case of new or non established vendors, creep data shall be made available by the contractor.
- ii) Tests shall be carried out on the casting material to establish its mechanical properties, chemical composition, and microstructure.
- iii) Each casting shall be subjected to magnetic particle examination on the entire inner and outer surfaces after heat treatment.
- iv) Each casting shall be subjected to visual examination and dimensional check before taking up the machining work on it. Dimensional check shall be carried out after machining also.
- v) Each casting shall be subjected to a 100% examination for internal flaws by UT or RT method after heat treatment and suitable preparation.
- vi) Cast enclosure shall be subjected to a hydraulic pressure test based on established practice of manufacturer.
- vii) Excavated area of all the defects shall be subjected to MPE to ensure excavation up to sound area. All the areas repaired/ upgraded by welding shall be examined by UT, RT (to confirm findings of UT wherever required) and MPE. Sketches/ reports of location of repair and reports of NDT carried out on repaired areas shall be submitted alongwith certificates. Hardness survey shall be carried out on the repaired areas.
- viii) Where stub pipes and transition pieces are welded to the main body of an enclosure the following shall be carried out:
 - a) RT and MPE or DPT of weld preparations.
 - b) MPE of finished welds after stress relieving.



- c) RT or UT of finished welds.
 - d) 100% RT or UT and MPE of site weld preparations on the stub pipes and transition pieces before dispatch to site.
 - e) Hardness survey on the weld joint, heat affected zone (HAZ) and parent material.
- ix) Wall thickness measurement for critical and highly stressed zones of the casting shall be carried out by ultrasonic method.
 - x) Colour matching of castings by putting two halves together and feeler gauge tightness check from both sides, i.e. inside and outside to ensure required contact area and joint tightness shall be carried out.

8.3.1.2 Low pressure (LP) enclosure (fabricated)

- i) Tests shall be carried out on the plate material to establish its mechanical properties and chemical composition.
- ii) Plates used for fabrication shall be subject to 100% UT.
- iii) Where welds are made by chipping and grinding back to the first side weld before completing the weld from second side, a magnetic particle or dye penetrant examination of the chipped area shall be carried out.
- iv) Fabricated enclosure shall be subjected to stress relieving as per manufacturer's standard practice.
- v) Dimensional check shall be carried out on the fabricated enclosure.
- vi) The following minimum requirements shall be met for NDT on the welds:
 - a) Butt welds & full penetration welds : 10% RT or UT and 10% MPE or DPT
 - b) Fillet welds : 10% MPE or DPT
 - c) Nozzle welds : 10% MPE or DPT
 - d) Lifting lug and other load bearing fillet welds : 100% MPE or DPT
 - e) Site weld edge preparations : 10% MPE or DPT



- vii) Fabricated enclosure shall be subject to hydraulic pressure tests. If it is not the manufacturer's practice, the justification for not carrying out hydraulic test shall be furnished for purchaser's approval.
- viii) Feeler gauge tightness check from inside and outside to ensure required joint tightness shall be carried out.

8.3.1.3 Turbine rotors

8.3.1.3.1 Forgings

Rotor forgings (mono block and/ or discs), impulse wheel and nozzle box and coupling forgings:

- i) Fully representative tangential, radial and axial test pieces shall be provided at each end of the body, at each shaft end and from the trepanned core (when a core is trepanned) to determine mechanical properties including impact, Brinell hardness etc. and tests for notch toughness (both transition temperature and room temperature impact values).
- ii) Forging supplier should have established practices to ensure requirements of creep and rupture for long exposure of the component to high temperatures and pressures.
- iii) Heat treatment shall be carried out in such a way so as to ensure minimum residual stress in the rotor. Residual stress measurement will be carried out.
- iv) Tests shall be carried out on the forging material to establish its mechanical properties, chemical composition and micro structure.
- v) Thermal stability tests shall be carried out on HP and IP rotor forgings to ensure the thermal stability of the rotors in service and at overspeed.
- vi) Each forging shall be subjected to a 100% ultrasonic examination. Normal probes and angular probes with different probe angles shall be used for thorough examination to ensure complete soundness of the forging
- vii) Each rotor shall be subjected to a 100% MPE after final machining on journal areas and before gashing on other areas.
- viii) When a rotor forging is bored, a visual check and magnetic particle examination of the bore shall be carried out.
- ix) Following tests shall be carried out on the rotor welds:
 - a) Ultrasonic examination with normal and angular probes of the weld to ensure complete coverage and freedom from harmful defects.
 - b) Run out of rotor before and after welding.



- c) MPE on finish welds.
- d) Hardness survey on the welds.
- e) Stress relieve annealing.
- f) Test reports of filler material used.
- g) Dimensional record of weld preparation.
- x) Dimensional examination of the rotor blade grooves and other important dimensions shall be carried out to ensure the conformance to drawing dimensions and log sheets/records shall be prepared for all important dimensions.

8.3.1.3.2 Complete rotors

- i) Axial & radial run-outs and surface finish checks shall be carried out before and after blading and after overspeed tests. Run out examination shall be carried out at blade shrouds also.
- ii) Check shall be carried out for clearance between rotor groove and blade at the root.
- iii) Rotors shall be dynamically balanced at rated speed.
- iv) An overspeed test shall be carried out during which the rotor shall withstand an overspeed of 120% for five continuous minutes or 125% for two continuous minutes. If bidder's practice is different from that stated above, then the same shall be furnished for purchaser's approval. During overspeed test, vibration measurement and analysis shall also be carried out.
- v) After blading and again after overspeed testing, rotor stages with blades over 225 mm of active length are to be subject to standing vibration tests to determine natural frequencies in various vibration modes to ensure that the ranges are outside operating frequencies.
- vi) In case impulse stage and or blade discs are fitted on the rotor, fit up between such disc and rotor shall be checked up before and after overspeed test.
- vii) Lock blade lift after the overspeed test shall be checked and record for same shall be maintained.

8.3.1.4 Stator and rotor blades and shroud bands

- i) Fully representative test pieces shall be provided to enable mechanical properties of the material to be determined. In case of blades machined from bar stock, mechanical tests shall be carried out on the hardest and softest specimens of each heat treatment batch. Hardness test will be carried out on 100% basis.



- ii) Tests shall be carried out on the materials to establish its mechanical properties, chemical composition and micro structure.
- iii) Each bar stock for machining blades and forging shall be subjected to 100% ultrasonic examination.
- iv) When erosion shielded, the erosion shield and blade joint shall be radiographed.
- v) Dye penetrant test shall be made on the erosion shield and blade joint in manufacture prior to fitting to the wheel and after overspeed tests.
- vi) Magnetic particle examination or dye penetrant test (when MPE is not applicable) shall be carried out on finish machined blade profile, roots and shrouds.
- vii) All moving blades of over 225mm active length are to be moment weighed and assembled on shaft in a prescribed sequence to ensure optimum balancing of rotor.
- viii) Natural frequencies of the LP turbine blades shall be determined before mounting on rotors to ensure that the same are outside operating frequency range.
- ix) Shroud bands after punching and after rivetting shall be subjected to 100% DPT to ensure freedom from harmful surface defects.
- x) In case of cast blades, following testing shall be done:
 - a) Chemical analysis and mechanical testing per heat/heat treatment batch.
 - b) MPE on rough machined and finish machined blade.
 - c) RT on blades.
 - d) Before starting mass productions, following technological tests shall be carried out on the first lot of 10 to 15 blades:
 - 100% RT and 100% MPE on blades
 - 100% hardness testing.
 - Mechanical testing and metallurgical testing.
 - Weld repair shall not be permitted.

8.3.1.5 Diaphragms

- i) Welded and fabricated diaphragms
 - a) Concentricity checks shall be carried out on final machined diaphragms to ensure that there are no negative overlaps between guide and moving blades.



- b) 10% UT and 100% MPE shall be carried out on finished, stress relieved and machined welds. For inaccessible areas, DPT shall be carried out in place of MPE.
- ii) Cast, forged and machined diaphragms
 - a) Tests shall be conducted to determine mechanical properties together with chemical analysis, metallographic/ metallurgical examination, and required heat treatment.
 - b) Concentricity, flatness, blade drop and area checks shall be carried out on finally machined diaphragms to ensure that there are no negative overlaps between guide and moving blades and port wall.
 - c) 100% ultrasonic examination shall be carried out on diaphragm materials. Blade junction areas with the side walls shall be checked by MPE or DPT.
- iii) Colour matching of all the diaphragms by putting two halves together and feeler gauge tightness check shall be carried out.

8.3.1.6 Exhaust hood

All castings shall be subjected to chemical and mechanical tests as per relevant material standards. In case of fabricated construction of exhaust hood, butt welds shall be subjected to 10% RT and 100% DPT. Exhaust hood shall be pressure tested. No repair of welding shall be carried out on cast iron castings. Blue matching shall be carried out on exhaust hood parting planes.

8.3.1.7 Stop, control and bypass valves, actuators/ servo-motors and steam strainers

- i) Test pieces shall be provided to enable the determination of mechanical properties of valve bodies, bonnets, valve disc and seat, and valve spindle. Casting suppliers should have established practices to ensure requirements of creep and rupture for long exposure of the component/ equipment to high temperatures and pressures.
- ii) Tests shall be carried out on the materials to establish their mechanical properties, and chemical compositions.
- iii) Dye penetrant tests shall be carried out on stellite and nitrided areas of components and on stellite components in the finish ground or honed condition.
- iv) Hardness check shall be carried out to ensure required hardness.
- v) Valve body and bonnet castings or forgings shall be subjected to 100% RT or 100% UT. Body and bonnet shall also be subjected to 100% MPE on entire surface.



- vi) All pressure containing welds in body and bonnet shall be subjected to 100% RT or UT and 100% MPE.
- vii) Wall thickness of the body and bonnet after finish machining shall be measured by ultrasonic method and valve seat bore shall be checked for size and concentricity.
- viii) Dimensions of valve spindle shall be measured and valve lift shall be checked.
- ix) Bar stock of 50 mm and above size for valve stem shall be subjected to UT, and finish machined stem shall be subjected to MPE or DPT.
- x) Each valve body and bonnet shall be hydraulically tested at minimum 1.5 times the maximum working pressure after applying temperature corrections.
- xi) All the actuating cylinders and servomotors shall be performance tested.
- xii) Performance testing shall be carried out on valve operators and actuators to check functional requirements like trip closing and opening time, valve lift and hysteresis.
- xiii) Colour matching of the valve disc and seat to ensure the required contact area is to be carried out.

8.3.1.8 Cast and forged steel components (such as LP casing- in case of cast design, inlet, extraction and exhaust connections, shaft seal covers and rings, governor shaft, breach nut, threaded ring, angle ring, U-ring, servomotor parts such as body, piston, cover, yokes; turning gear casing and other items which are not specifically covered elsewhere)

- i) Results of tests conducted to determine mechanical properties, chemical analysis, metallurgical/ metallographic examination, and heat treatment procedures recommended and actually followed shall be recorded on certificates.
- ii) Each pressure containing enclosure shall be subjected to a hydraulic pressure test at 1.5 times the design pressure and after applying temperature corrections.
- iii) All castings and forgings shall be subject to suitable non-destructive examination by RT or UT and MPE or DPT methods to ensure freedom from harmful defects.

8.3.1.9 Bolts and nuts for pressure retaining enclosures and rotor couplings

- i) Bar stock for bolts shall be subject to 100% UT.
- ii) Finish machined bolts shall be subject to preferably 100% MPE to detect surface defects. However, DPT can also be done in place of MPE.
- iii) Coupling bolts and nuts shall be suitably identified after weight control checks.



8.3.1.10 Governing and protection system equipment (such as electro-hydraulic controller, hydraulic amplifier, hydraulic controller, electro hydraulic convertors, hydraulic convertors, hydraulic speed governor, trip devices etc.)

- i) All pressure retaining parts shall be subjected to hydraulic testing.
- ii) All the major castings and forgings shall be subjected to suitable NDT methods depending upon their application and criticality to ensure the freedom from harmful defects.
- iii) All the main assemblies and sub-assemblies shall be subjected to functional test.
- iv) All butt welds shall be subjected to minimum 10% RT or UT and all fillet and corner welds shall be subjected to MPE or DPT.
- v) All control equipment shall be subjected to rig testing, if it is not possible to test it on the steam turbine light run. The purpose of rig testing shall be as far as practical to prove that the functioning of the control equipment is in accordance with the approved design.
- vi) Nitrided and stellite components shall be subject to DPT and hardness check.

8.3.1.11 Inspection of completed turbine

- i) HP and IP turbines

The steam turbine shall be assembled in the manufacturer's works to such an extent that a thorough inspection can be carried out. The purpose of this inspection shall be to ensure that the fit between mating components is correct and that all clearances are in accordance with the design requirement. The following minimum checks/ measurements shall be carried out on the assembled turbine:

- a) Check and measurement of clearance between shaft seal casing and shaft seal ring.
- b) Check and measurement of clearance in anti- rotational device in shaft seal casing joint.
- c) Check and measurement of axial and radial alignments of inner and outer casings.
- d) Check and measurement for radial and axial blade clearances in blading section.
- e) Check and measurement for axial and radial clearances in shaft seal.
- f) Check and measurement for tightness and elongation of horizontal joint inner casing bolts.



- g) Check and measurement of minimum axial clearances and minimum radial clearances in completely assembled steam turbine.
 - h) Check for alignment of overspeed governor.
 - i) Check for axial distances for shroud bands for casings.
 - j) No load running test on the steam turbine including functional tests for steam turbine control and emergency control equipments.
 - k) Pre- dispatch inspections including clearance check for transportation device.
- ii) LP Turbines

For the LP turbine, the following minimum checks/ measurements shall be carried out on the assembled turbine at the manufacturer's works:

- a) Check and measurement of axial and radial alignments of inner and outer casings.
 - b) Check and measurement for radial and axial blade clearance in blading section.
 - c) Check and measurement of minimum axial clearances and minimum radial clearances in completely assembled steam turbine.
 - d) Check and measurement for alignment of stationary blade carriers.
 - e) No load running test on the steam turbine including functional tests for steam turbine control and emergency control equipments.
 - f) Pre- dispatch inspections including clearance check for transportation device.
- iii) No load running tests on complete steam turbine shall be carried out as per manufacturer's standard practice.

8.3.2 Integral Auxiliaries of Steam Turbine

8.3.2.1 Bearing pedestals, housings and bearings

- i) Leakage test shall be conducted on pedestals. For fabricated pedestals and housing, 10% weld shall be checked after stress relieving by magnetic particle test and minimum 10% of the butt welds shall be checked by RT or UT.
- ii) Bearing shell
 - a) The shell shall be subjected to suitable non destructive examination like RT or UT and/or MPE as applicable.



- b) Colour matching of the shell by putting two halves together and feeler gauge tightness checks from inside and outside to ensure required contact area and joint tightness shall be carried out.
- c) The shell shall be subjected to hydraulic pressure test.
- d) Chemical analysis of white metal shall be carried out. The effectiveness of the white metal adhesion shall be checked by UT or other approved method, and the exposed edges of the white metal shall be subject to DPT.
- e) Hydraulic test shall be carried out for bearing oil inlet piping and jacking oil piping.
- f) Alignment check shall be made for bearing in bearing pedestal.

8.3.2.2 Cross around pipes

- i) Weld edge preparation of shop and site welds shall be checked by 100% MPE.
- ii) All butt welds shall be subjected to 100% RT.
- iii) 100% MPE shall be carried out on all welds.
- iv) Check for dimensions and visual inspection shall be carried out on finished pipes.

8.3.2.3 Lubricating oil, jacking oil and control oil systems

- i) Pumps
 - a) Main oil pump shaft shall be subjected to ultrasonic examination. Butt welds shall be subjected to RT or UT.
 - b) Pump impeller shall be subjected to suitable NDT method like MPE or DPT for surface defect examination. Impeller of main oil pumps shall also be subjected to an overspeed test at 120% of rated speed for 5 minutes.
 - c) Pump casing shall be subjected to hydraulic pressure test at 2 times the working pressure or 1.5 times the pump shut off head whichever is higher.
 - d) Rotor assemblies shall be dynamically balanced.
 - e) All pumps shall be performance tested at the manufacturer's works. Test shall include check for vibration and noise levels also.
- ii) Coolers and lubricating oil tanks
 - a) All raw materials used shall have co-related mill test certificate meeting mandatory and supplementary checks of material specification.



- b) Material for tube plates shall be ultrasonically tested. Drilled tube plates shall be checked for ovality of holes, ligaments, surface finish etc.
 - c) Dished ends shall be subjected to 100% MPE and RT or UT on welded joints. Knuckle portion shall be checked by MPE for surface defects and thinning shall be checked by UT.
 - d) Butt welds and full penetration welds shall be checked by suitable RT or UT. Fillet welds shall be checked by MPE or DPT.
 - e) Tubes shall be tested as per the relevant codes or standards.
 - f) Before tubes expansion in the tube sheets, the mockup test for expansions shall be carried out, in case not done earlier. Torque setting of expander shall be based on mock up tests. Joints shall be checked for tube thinning.
 - g) Completed assemblies shall be pressure tested. The twin oil coolers shall be tested on both tube side and shell side. After hydrotest, the coolers shall be suitably dried.
 - h) Atmospheric tanks shall be tested for leakage by water fill test for atleast 12 hrs.
- iii) Oil purifiers
- a) All pressure parts shall be subjected to hydraulic pressure test.
 - b) Components/ parts of the equipment shall be subjected to suitable NDT depending upon the criticality of the application to ensure freedom from surface and sub surface defects.
 - c) All rotating parts like bowl assembly etc. shall be subjected to static and dynamic balancing test.
 - d) The complete purifier shall be tested at manufacturer's works for capacity, mechanical running, sequential operation and interlocks, moisture content, vapour tightness, vibration, noise level, quality improvements etc. Sample shall be drawn from inlet and outlet of purifier after works test and shall be tested for moisture content, chemical tests and particle size of impurities. . In case, type test has already been carried out by the contractor for the offered model of the centrifuge, the test shall not be repeated and certificates of test carried out earlier shall be furnished for review of the purchaser. The validity of the type test carried out earlier shall be limited to five (5) years.



8.3.3 Steam Condenser

8.3.3.1 Condenser

- i) Tests shall be carried out on the materials of plates, tubes and nozzles etc. to establish their mechanical properties, and chemical compositions.
- ii) Plates shall be subject to 100% ultrasonic testing.
- iii) Tubes shall be subject to dimensional check, 100% eddy current test and 100% hydraulic test. In place of hydraulic test, air under water or Helium leak detection test can also be carried out.
- iv) Forgings of the nozzles shall be subject to 100% UT and 100% MPE.
- v) All welds shall be visually examined. Radiographic examination of 10% of butt welds shall be carried out. However, for vacuum containing welds, RT on atleast 10% of each butt weld shall be carried out. Surface defect examination by MPE or equivalent test method shall be carried out for minimum 10% weldments. Nozzle welds shall be subject to 100% MPE or DPT. These shall apply to site welds also.
- vi) All edge preparations shall be examined for surface defects. Edge preparation for welds to be carried out at site shall be checked by magnetic particle examination method before dispatch.
- vii) In case of fabricated flanges, welds shall be checked by 100% RT or UT and 100% MPE to ensure freedom from internal and surface defects.
- viii) To ensure dimensional control of condenser, parts/ sub assemblies shall be trial assembled at shop. Trial insertion of a few tubes through main tube plates and support plates shall be carried out to ensure alignment of tube plates and proper fitting and matching of parts and sub-assemblies.

8.3.3.2 Spring assembly

- i) Static load testing of the springs shall be carried out and spring characteristics shall be drawn and verified.
- ii) Surface defect test shall be carried out on all the springs after coiling and heat treatment.

8.3.3.3 Condenser air evacuation system

- i) Vacuum pumps
 - a) Vacuum pump shafts shall be subject to ultrasonic test. After finish machining, shaft shall be subject to 100% MPE or DPT.



- b) Pump casings and impellers shall be subject to MPE or DPT. Finished pump rotor shall be subject to dynamic balancing.
 - c) Pump casings shall be subjected to hydraulic test at 1.5 times the shut off pressure or twice the maximum operating pressure, whichever is higher.
 - d) Each pump shall be tested at supplier's works at full speed and load conditions to demonstrate successful operation and performance in accordance with the design requirements. Visual cavitation test shall also be carried out to demonstrate that pump shall be operating under all operating condition including blank off condition without any cavitation.
- ii) The complete package shall be subjected to hydraulic pressure and leakage test and shop tested to check interlocks and functional requirements. The one complete unit shall also be subjected to demonstrate successful operation and performance testing, with saturated air conditions at condenser design vacuum point as well as vacuum pump design point with total minimum three points. The test shall be conducted with the respective motors to be supplied. The test shall include check for vibration and noise level also.

8.3.4 Feed water heaters, drain coolers, gland steam condenser and deaerator

8.3.4.1 Heaters, drain coolers and gland steam condensers

- i) Tests shall be carried out on the materials of forgings, plates and tubes etc. to establish their mechanical properties, and chemical compositions.
- ii) Nozzle forgings shall be subject to suitable heat treatment and 100% ultrasonic testing.
- iii) Tubes
 - a) Tubes shall be subject to dimensional check.
 - b) 100% eddy current test shall be carried out for tube thickness < 3.6 mm and 100% UT for tube thickness ≥ 3.6 mm.
 - c) Tubes shall be subject to 100% hydraulic test.
 - d) Flattening and flaring tests shall also be carried out for the tubes as per applicable codes.
 - e) Before tubes expansion in the tube sheets, the mockup test for expansions shall be carried out. Torque setting of expander shall be based on mock up tests. Joints shall be checked for tube thinning.
- iv) Tube sheets
 - a) Tube sheets shall be subject to visual examination and dimensional check.



- b) Impact test shall be carried out for the plate materials.
 - c) 100% UT and 100% DP test shall be carried out after overlay and machining. In case overlay is not applicable, only 100% UT shall be carried out.
 - d) For clad plates, bonding shall be checked by UT. Drilled tube plates shall be checked for ovality of holes, ligaments, surface finish etc.
 - e) Tube to tube sheet weld joints shall be subject to 100% DP test. These joints shall also be subject to air test.
- v) Shell, dished ends and hemi heads
- a) Impact test shall be carried out for the plate materials.
 - b) 100% UT shall be carried out on the finished and formed dished ends and hemi heads.
 - c) Dished ends shall be subject to dimensional check after dishing.
 - d) Knuckle portion shall be checked by 100% MPE or DPT for surface defects and check for thinning shall be carried out by UT.
- vi) Welding
- a) Root run of butt welds shall be examined by 100% DPT or MPE.
 - b) Butt welded and full penetration joints and nozzle welds shall be checked by 100% RT or UT and 100% MPE or DPT.
 - c) Fillet welds shall be checked by 100% MPE or DPT.
 - d) All weldments shall be given suitable heat treatment.
- vii) Visual check and dimensional measurement shall be carried out on the completed equipment.
- viii) Completed assembly shall be pressure tested with working-fluid using hydraulic and pneumatic method. The heat exchangers shall be tested on both tube side and shell side. After hydro test, the heat exchangers shall be suitably dried and nitrogen capped.

8.3.4.2 Deaerator

- i) Tests shall be carried out on the materials of forgings, plates and tubes etc. to establish their mechanical properties, and chemical compositions.



- ii) Forgings shall be subject to suitable heat treatment and 100% ultrasonic testing.
- iii) Shell and dished ends
 - a) Impact test shall be carried out for the plate materials.
 - b) 100% UT shall be carried out on the finished/ formed plates.
 - c) Dished ends shall be subject to dimensional check after dishing.
 - d) Knuckle portion shall be checked by 100% MPE or DP test for surface defects and check for thinning shall be carried out by UT.
- iv) Welding
 - a) Root run of the butt welds shall be examined by 100% DPT or MPE.
 - b) Butt welded and full penetration joints and nozzle welds shall be checked by 100% RT or UT and 100% MPE or DPT.
 - c) Fillet welds shall be checked by 100% MPE or DPT.
- v) Visual check and dimensional measurement shall be carried out on the completed equipment.
- vi) Completed assembly shall be pressure tested with working-fluid using hydraulic method.

8.3.4.3 Valves on heaters and deaerator

- i) Tests shall be carried out on the materials of forgings, plates and tubes etc. to establish their mechanical properties, and chemical compositions.
- ii) 100% RT or UT shall be carried out on bodies, bonnets, nozzles and stem of valves of HP heaters.
- iii) 100% DPT or MPE shall be carried out on machined surfaces of valve body, bonnet, stem, disc and springs.
- iv) Valve body shall be subject to hydraulic testing.
- v) Valve seat shall be subject to hydro leak test as per ANSI 16.34.
- vi) Visual check and dimensional measurement shall be carried out on the completed valve assembly.



8.3.5 Boiler Feed Pumps

8.3.5.1 Main pump

- i) Tests shall be carried out on the materials on various components to establish their mechanical properties and chemical composition. Further, heat treatment shall be given as required.
- ii) 100% UT shall be carried out on barrel casing, casing cover, suction & discharge branches, shaft, ring sections, and wearing rings.
- iii) 100% RT shall be carried out on suction branch, impellers and diffusers.
- iv) 100% MPE shall be carried out on barrel casing, casing cover, suction & discharge branches, gland housing, shaft, diffusers, balancing drum and spring disc.
- v) 100% DPT shall be carried out on welds and overlay preparation on barrel casing, and machined components after final machining.
- vi) Hydraulic test shall be carried out on barrel casing, discharge cover, and suction and discharge branches.
- vii) Individual impellers and completed rotor assembly shall be subject to dynamic balancing test. Rotor assembly shall be subject to run out test also.
- viii) Hardness test shall be carried out on wearing rings.
- ix) Visual check and dimensional measurement shall be carried out for all the components and completely assembled pump.
- x) Final tests
 - a) Performance testing shall be carried out as per Hydraulic Institute Standards (HIS) on each pump to determine its characteristic curve at design speed and to ensure compliance with design requirements. Tests shall be carried out with loop water at specified design temperature. Soften quality water shall be used for the performance testing.
 - b) Vibration on all pumps shall be measured in transverse, horizontal and vertical direction at all measuring points.
 - c) Noise Level on each pump shall be measured at a distance of 1.5 m above floor level in elevation and 1 m horizontally from the nearest surface of the equipment as per HIS. The measurement shall be taken at six points around the equipment for each flow condition.



d) Type tests

- NPSH (R) test shall be carried out on one pump using cold water at pump flows of 25%, 50%, 80%, 100% and 125% of design flow at design speed. This shall be preferably done at 1% and 3% head break by suction throttling procedure. In case, NPSH (R) test has already been carried out by the contractor for the offered frame of BFP, the test shall not be repeated and certificates of test carried out earlier shall be furnished for review of the purchaser. The validity of the type test carried out earlier shall be limited to five (5) years.
- Pressure pulsation and axial thrust measurement shall be carried out on one boiler feed pump at all measuring points. Pressure pulsation shall be measured at suction as well as at discharge in the operating range.
- Thermal shock test shall be carried out on one pump with measurements taken on all critical areas such as barrel, discharge branch, casing cover, casing cover stud.
- Dry running withstand capability shall be demonstrated and established on one pump. The pump shall be capable of accepting complete loss of water and must be capable of being shut down in a controlled manner and brought down to rest after being tripped from design condition with simultaneous closure of suction valve.
- Visual cavitation test on one first stage production impeller shall be carried out to demonstrate absence of cavitation at design speed in cold water. The test shall establish the cavitation characteristic to confirm that the cavity length under dynamically scaled site conditions corresponding to design point shall not exceed an acceptable size. This test shall be carried out at 25%, 50%, 80%, 100% and 125% of design flow.

e) Strip down test

Complete strip down of one feed pump which undergoes NPSH test, dry run test, thermal shock test etc. shall be done after completion of all the tests on it. The strip down shall check for the condition of thrust bearing and journal bearing, and problems such as internal rubbing damage, excessive wear on the components. For other feed pumps, strip down examination shall be restricted to inspection of bearings only. However, if excessive vibration, high noise, high bearing temperature etc. is observed during performance test of any feed pump, complete strip down shall be done for such pumps also.



Note: Tested pump parameters shall be within following tolerances.

At design head	: + 10% of design capacity
At design capacity	: + 5% of design head (for < 152.4 m) + 3% of design head (for ≥ 152.4 m)

The results of the performance test must show no minus tolerance with regard to flow and head. No minus tolerance on efficiency or positive tolerance on power input at motor terminals shall be allowed.

8.3.5.2 Booster pump

- i) Tests shall be carried out on the materials on various components to establish their mechanical properties and chemical composition. Further, heat treatment shall be given as required.
- ii) 100% UT shall be carried out on shaft and wearing rings.
- iii) 100% MPE shall be carried out on casing, impeller and seal cooling jacket.
- iv) 100% DPT test shall be carried out on machined components after final machining.
- v) Hydraulic test shall be carried out on pump casing at 1.5 times the shut off pressure or 2 times the working pressure whichever is higher.
- vi) Impeller and completed rotor assembly shall be subject to dynamic balancing test. Rotor assembly shall be subject to run out test also.
- vii) Visual check and dimensional measurement shall be carried out for all the components and completely assembled pump.
- viii) Final tests
 - a) Performance testing shall be carried out as per Hydraulic Institute Standards (HIS) on each pump to determine its characteristic curve at design speed and to ensure compliance with design requirements. Tests shall be carried out with loop water at specified design temperature. Soften quality water shall be used for the performance testing.
 - b) Vibration on all pumps shall be measured in transverse, horizontal and vertical direction at all measuring points.
 - c) Noise Level on each pump shall be measured at a distance of 1.5 m above floor level in elevation and 1 m horizontally from the nearest surface of the equipment as per HIS. The measurement shall be taken at six points around the equipment for each flow condition.

d) Type tests

- NPSH (R) test shall be carried out on one pump using cold water at pump flows of 25%, 50%, 80%, 100% and 125% of design flow at design speed. This shall be preferably done at 1% and 3% head break by suction throttling procedure. In case, NPSH (R) test has already been carried out by the contractor for the offered frame of booster pump, the test shall not be repeated and certificates of test carried out earlier shall be furnished for review of the purchaser. The validity of the type test carried out earlier shall be limited to five (5) years.
- Dry run withstand capability shall be demonstrated and established on one pump.

e) After performance testing, thrust bearing and journal bearing shall be subject to visual check.

Note: Tested pump parameters shall be within following tolerances.

At design head : + 10% of design capacity

At design capacity : + 5% of design head (for < 152.4 m)
+ 3% of design head (for ≥ 152.4 m)

The results of the performance test must show no minus tolerance with regard to flow and head. No minus tolerance on efficiency or positive tolerance on power input at motor terminals shall be allowed.

8.3.5.3 Gear box and hydraulic coupling

- i) Tests shall be carried out on the materials on various components to establish their mechanical properties and chemical composition. Further, heat treatment shall be given to the internal components as required.
- ii) Internal components such as gears, pinions, wheels and shafts shall be examined by 100% UT and 100% DPT or 100% MPE.
- iii) Leak test shall be carried out for the casing.
- iv) Dynamic balancing test shall be carried out for the assembled rotating component.
- v) Full load speed and back to back locked rotor torque test shall be carried out on one gear box.
- vi) Visual check and dimensional measurement shall be carried out for the completely assembled equipment.



8.3.5.4 Strainers

- i) Tests shall be carried out on the materials on various components to establish their mechanical properties and chemical composition.
- ii) In case of fabricated construction, the welds shall be examined for surface defects by 100% DPT.
- iii) The strainer body shall be subject to hydraulic test.
- iv) Pressure drop test shall be carried out for each type and size of the strainer assembly.

8.3.5.5 BFP drive turbine and associated equipment

The QA requirements for BFP drive turbine and associated auxiliaries shall be same as those applicable for main steam turbine and its auxiliaries described at clause 8.3.1 of this Section.

8.3.6 Condensate Extraction Pumps (CEPs)

8.3.6.1 Pump

- i) Tests shall be carried out on the materials on various components to establish their mechanical properties and chemical composition. Further, heat treatment shall be carried out for materials of shaft and rotor.
- ii) 100% UT shall be carried out on pump shaft.
- iii) 10% RT shall be carried out for butt welds on fabricated components of thickness more than 10 mm.
- iv) 100% MPE shall be carried out on pump shaft.
- v) 100% DPT shall be carried out on welds on casing, suction bell, shaft, impeller and fabricated components.
- vi) Hydraulic test shall be carried out on casing and pressure containing fabricated parts at 1.5 times the pump shut off pressure or 2 times the working pressure whichever is higher.
- vii) Individual impellers and completed rotor assembly shall be subject to dynamic balancing test. Rotor assembly shall be subject to run out test also.
- viii) Visual check and dimensional measurement shall be carried out for all the components and completely assembled pump.



ix) Final tests

- a) Performance testing shall be carried out as per Hydraulic Institute Standards (HIS) on each pump to determine its characteristic curve at design speed and to ensure compliance with design requirements. Tests shall be carried out using cold soften quality water.
- b) Vibration on all pumps shall be measured in transverse, horizontal and vertical direction at all measuring points.
- c) Noise Level on each pump shall be measured at a distance of 1.5 m above floor level in elevation and 1 m horizontally from the nearest surface of the equipment as per HIS. The measurement shall be taken at six points around the equipment for each flow condition.
- d) NPSH test

NPSH (R) test shall be carried out on one pump using cold water at pump flows of 25%, 50%, 80%, 100% and 125% of design flow at design speed. This shall be preferably done at 1 % and 3% head break. In case, NPSH (R) test has already been carried out by the contractor for the offered frame of CEP, the test shall not be repeated and certificates of test carried out earlier shall be furnished for review of the purchaser. The validity of the type test carried out earlier shall be limited to five (5) years.

- e) Strip down test

Complete strip down of one pump which undergoes NPSH test shall be done after completion of all the tests on it. The strip down shall check for the condition of bearings and problems such as internal rubbing, excessive wear. For other pumps, strip down shall be restricted to inspection of bearings only. However, if excessive vibration, high noise etc. is observed during performance test of any pump, complete strip down shall be done for such pumps also.

Note: Tested pump parameters shall be within following tolerances.

At design head : + 10% of design capacity

At design capacity : + 5% of design head (for < 152.4 m)
+ 3% of design head (for ≥ 152.4 m)

The results of the performance test must show no minus tolerance with regard to flow and head. No minus tolerance on efficiency or positive tolerance on power input at motor terminals shall be allowed.

8.3.6.2 Strainers

The QA requirements for strainers at suction of the CEPs shall be same as those applicable for BFP strainers described at clause 8.3.5.4 of this Section



8.3.7 Condensate Polishing Unit (CPU)

8.3.7.1 CPU service vessels

- i) Tests shall be carried out on the materials of the vessels, internals and rubber used for lining to establish their mechanical properties, and chemical compositions. Heat treatment as required shall be done as per ASME code.
- ii) Plates shall be subject to 100% ultrasonic testing.
- iii) Impact test shall be carried out for the plate materials.
- iv) 100% UT shall be carried out on the finished and formed dished ends and hemi heads.
- v) Welding
 - a) Root run of butt welds shall be examined by 100% DPT or MPE.
 - b) Butt welds full penetration joints and nozzle welds shall be checked by 100% RT and 100% MPE or DPT.
 - c) Fillet welds shall be checked by 100% MPE or DPT.
- vi) Rubber lining shall be subjected to following tests as per IS-4682 part-I or acceptable equivalent:
 - a) Adhesion test
 - b) Measurement of thickness
 - c) Shore hardness test
 - d) Visual examination and spark test at 5 kV/mm of thickness
 - e) Bleeding resistance test with keeping the sample in 33% HCl, 48% NaOH and DM water for 72 hours.
- vii) Visual check and dimensional measurement shall be carried out on the completed equipment.
- viii) Internals of the vessel shall be subject to dimensional check and applicable tests as per relevant codes.
- ix) The fabricated vessel shall be hydraulically tested at 1.5 times the working pressure before the rubber lining and at the working pressure after the rubber lining.



8.3.7.2 Acid/ alkali handling tanks

- i) Tests shall be carried out on the materials of the tanks to establish their mechanical properties, and chemical compositions
- ii) Plates shall be subject to 100% ultrasonic testing.
- iii) Welding
 - a) Root run of butt welds shall be examined by 100% DPT or MPE.
 - b) Butt welds, full penetration joints and nozzle welds shall be checked by 100% RT and 100% MPE or DPT.
 - c) Fillet welds shall be checked by 100% MPE or DPT.
- iv) Rubber lining shall be subject to relevant tests as described for CPU vessels.
- v) Visual check and dimensional measurement shall be carried out on the completed equipment.
- vi) The fabricated tank shall be subject to water fill test to check for the leakage.

8.3.7.3 Dosing pumps/ metering pumps

- i) Tests shall be carried out on the materials of the pumps to establish their properties, and chemical compositions
- ii) Pump casings shall be subject to hydraulic test at 1.5 times the shut off pressure or 2 times the working pressure whichever is higher.
- iii) Pumps shall be performance tested as per HIS, USA.

8.3.7.4 Horizontal centrifugal pumps

The QA requirements for horizontal centrifugal pumps shall be as per clause 8.4.12.2 of this Section.

8.3.7.5 Rotary blowers

- i) Tests shall be carried out on the materials of the rotary blowers to establish their properties, and chemical compositions.
- ii) 100% DPT or MPE shall be carried out for the rotor and machined surfaces of casing and impellers.
- iii) The shaft and impellers shall be dynamically balanced.



- iv) Assembly fit up check, and dimensional check shall be carried out for the completed blower assembly.
- v) The blower casing shall be subject to hydraulic test at 1.5 times the shut off pressure or 2 times the working pressure whichever is higher.
- vi) The blowers shall be performance tested as per relevant code/ standard.

8.3.7.6 Valves

The QA requirements for high pressure valves such as for service vessels shall be as per clause 8.4.2 of this Section. The QA requirements for other valves shall be as per clause 8.4.6.2 of this Section.



8.3.8 Condenser On-Line Tube Cleaning System

8.3.8.1 Ball recirculation pump

- i) All rotating parts shall be dynamically balanced.
- ii) Pump casing shall be subjected to hydraulic test at 1.5 times the shut off head or twice the maximum working pressure whichever is higher.
- iii) Complete pump assembly shall be subjected to shop performance test at supplier's works.

8.3.8.2 Ball sorter/ fabricated body (housing)

- i) In the case of fabricated design, all butt welds shall be subject to 10% RT or UT. All welds shall also be subjected to 10% MPE to ensure freedom from surface and sub-surface defects.
- ii) Body shall be subject to hydraulic pressure test at 1.5 times the design pressure.
- iii) Performance test shall be carried out on ball sorter assembly.

8.3.8.3 Strainer

- i) Tests shall be carried out on the materials on various components to establish their mechanical properties and chemical composition
- ii) Strainer mesh shall be checked for chemical composition and mesh size.
- iii) Strainer body shall be subject to hydraulic pressure test at 1.5 times the design pressure.
- iv) Strainer assembly shall be checked for its functional performance.

8.3.8.4 Piping and fittings

- i) Butt welds on piping shall be subject to 10% RT and 10% DPT. Butt welds on segmental flanges shall be checked by 100% RT and 100% DPT.
- ii) Fillet welds with load transfer shall be subject to 100% MPE or DPT and fillet welds without load transfer shall be subjected to 10% MPE or DPT.
- iii) Wrought and forged fittings shall be tested as per relevant codes or standards.

8.3.8.5 Coating/ lining

- i) Coating shall be checked for DFT and adhesion. Further, Contractor shall furnish his practice for testing of coating to ensure the uniformity and freedom from pinholes.



- ii) Rubber lined items shall be hydraulically tested before rubber lining. All rubber lining shall be subjected to following tests as per IS-4682 part-I or acceptable equivalent:
 - a) Adhesion test
 - b) Check for resistance to bleeding
 - c) Measurement of thickness
 - d) Shore hardness test
 - e) Visual examination and spark test at 5 kV/mm of thickness.

8.3.8.6 Valves

The QA requirements for the valves shall be as per clause 8.4.6.2 of this Section.

8.3.9 Debris Filter

- i) Body, strainer mesh and other components shall be checked for chemical composition.
- ii) Strainer element shall be checked for mesh size.
- iii) Body shall be subject to hydraulic pressure test at 1.5 times the design pressure.
- iv) Filter assembly shall be checked for its functional requirements.
- v) Valves shall be tested as per relevant standards.



8.4 HIGH PRESSURE PIPING, VALVES, THERMAL INSULATION AND MISCELLANEOUS SYSTEMS/ EQUIPMENTS

8.4.1 High Pressure Piping and Fittings

- i) All raw materials used shall have co-related mill test certificate meeting mandatory and supplementary checks of material specification.
- ii) The pipes and fittings shall be subject to visual examination, identification, correlation and stamping.
- iii) For alloy steel pipes (SA 335, P11, P22, & P91), 25% pipes per lot shall be subject to the following tests:
 - a) Product analysis
 - b) Transverse tension test on pipes from one end for pipe size 200 mm and above.
 - c) Flattening test on pipe from one end.
- iv) All pipe lengths shall be subjected to 100% UT or hydraulic tests and UT or RT on longitudinal welds.
- v) All mother pipes used for fittings shall be subject to a hydraulic test or an ultrasonic test. Raw material of all forged fittings shall be ultrasonically tested. Forged fittings shall be ultrasonically tested.
- vi) All alloy and carbon steel pipes shall be subject to 100% UT for pipe thickness \geq 3.6 mm and 100% eddy current test for thickness $<$ 3.6 mm.
- vii) Thickness of all pipe bends (cold/ hot formed) shall be checked by ultrasonic or other acceptable methods on sample basis for high pressure applications. Further, outer surface of bends shall be subject to 100% MPE or DPT.
- viii) Welded and cast fittings, if any, shall be subjected to suitable NDT as per applicable standards. However, as a minimum, 100% RT shall be carried out on all alloy steel fittings and on carbon steel fittings for use above 71 bar design conditions.
- ix) The edge preparation for stainless steel/ alloy steel shall be subject to a 100% DPT. For other piping, the edge preparation for the welds shall be checked by 100% MPE or DPT.
- x) Non-destructive examination of welds shall be carried out in accordance with the relevant design and/or manufacturing codes. However, as a minimum, the following requirements shall be met (except for oil piping):
 - a) For temperature $>$ 400 $^{\circ}$ C and/or pressure exceeding 71 bar, the butt welds and full penetration branch welds shall be subject to 100% RT or UT and 100% MPE.



- b) For temperature $> 175^{\circ}\text{C}$ up to 400°C and/or pressure exceeding 17 bar and up to 71 bar, the butt welds & full penetration branch welds shall be subject to NDTs as below:
- pipe diameter > 100 NB 100% RT or UT and 100% MPE
 - pipe diameter ≤ 100 NB 10% RT or UT and 100 % MPE

In addition to above, statutory requirement, wherever applicable, shall also be complied with.

- xi) Finished welding for alloy steel piping, BFP discharge piping, MS piping, HRH piping, CRH piping and associated pipings shall be subject to the following NDTs:
- a) Butt welds 100% RT and 100% MT or DPT
 - b) Welds for nozzle, branch connections of size $> 100\text{NB}$ 100% RT and 100% MT or DPT
 - c) Welds for all other attachments 100% MT or DPT
 - d) Removal of weld defects 100% MT or DPT
- xii) Finished welding for Carbon Steel Class- I piping having design temperature > 218 deg C or design pressure for steam > 17.6 kg/ cm^2 (g) or design pressure for feed water > 24.6 kg/ cm^2 (g) shall be subject to the following NDTs:
- a) Butt welds:
 - pipe size > 100 NB 100% RT and 100% MPE or DPT
 - pipe size ≤ 100 NB 10% RT and 10% MPE or DPT
 - b) Welds for nozzle, branch connections of size $> 100\text{NB}$ and thickness > 19 mm 100% RT and 100% MPE or DPT
 - c) Welds for all other attachments 10% MPE or DPT
 - d) Removal of weld defects/weld repair 100% MPE or DPT
- xiii) Finished welding for carbon steel class- I piping having design temperature ≤ 218 deg C or design pressure for steam ≤ 17.6 kg/ cm^2 (g) or design pressure for feed water ≤ 24.6 kg/ cm^2 (g) shall be subject to the following NDTs:
- a) Butt welds:
 - pipe size > 100 NB 100% RT and 10% MPE or DPT
 - pipe size ≤ 100 NB 10% MPE or DPT
 - b) Welds for nozzle, branch connections/ attachments 10% MPE or DPT



- c) Removal of weld defects 100% MPE or DPT
- xiv) Non-destructive examination of welds shall be carried out after post weld heat treatment, if any.
- xv) Pre- heating, stress relieving and post weld heat treatment as applicable shall be carried out as per requirements of ASME B 31.1. For welds in P91, X20 & X22 materials, only induction type of heating shall be deployed for heat treatment.
- xvi) Hardness survey of welds shall be carried out on alloy steel/ stainless steel piping. (100% hardness survey of welds on P91, X20 & X22 material grade pipings).
- xvii) All other pipes not covered above (except oil piping) shall be subjected 100% MPE or DPT in case of under ground piping and 10% MPE or DPT in case of over ground piping. Further, 10% of butt welds of underground piping shall be subjected to RT.
- xviii) Oil piping shall be subjected to following NDTs.
- a) Butt welds of Oil piping shall be subjected to 10% RT and 10% DP Test. For Jacking oil lines 100% RT and 100% DPT shall be carried out on butt welds.
 - b) Fillet welds with load transfer shall be subjected to 100% MPE or DPT and fillet welds without load transfer shall be subjected to 10% MPE or DPT.
- xix) Rubber lined pipes shall be hydraulically tested before rubber lining. All rubber lining shall be subject to following tests as per IS-4682 part-I or acceptable equivalent:
- a) Adhesion test
 - b) Check for resistance to bleeding (if applicable)
 - c) Measurement of thickness
 - d) Shore hardness test
 - e) Visual examination and spark test at 5 kV/mm of thickness.



8.4.2 Power Cycle Valves

8.4.2.1 Valves other than extraction line valves and butterfly valves

- i) Bar stock/forging above 40mm diameter for valve trim shall be subjected to UT.
- ii) Hardened/ stellitted valve disc and seat are to be subjected to LPI and hardness check.
- iii) Colour matching of valve disc, plug and seat shall be carried out to ensure contact.
- iv) Hydraulic pressure test and seat leak test shall be carried out as per ANSI 16.34.
- v) Air seat leak test shall be carried out as per applicable standards/ codes.
- vi) Pressure retaining parts of valves shall be subject to NDTs as below:
 - a) Valve size < 50 NB
 - Visual examination for rating below ANSI Class 900
 - MPE for rating above ANSI Class above 900
 - b) Valve size \geq 50 NB and < 100 NB
 - Visual examination for rating upto ANSI Class 600
 - MPE for rating above ANSI Class above 600 and below 900
 - 100% MPE and 100% RT on 10% of valves for rating above ANSI Class above 900 and below 4500
 - c) Valve size \geq 100 NB and < 300 NB
 - Visual examination for rating upto ANSI Class 300
 - MPE for rating above ANSI Class above 300 and below 600
 - 100% MPE and 100% RT on 10% of valves on change of section and weld ends for rating above ANSI Class above 600 and below 900
 - 100% MPE and 100% RT on valves for rating above ANSI Class 900 and below 4500
 - d) Valve size \geq 300 NB
 - MPE for rating upto ANSI Class 600
 - 100% MPE and 100% RT on all valves in the areas of change of section and weld ends for rating above ANSI Class 600 and below Class 900



- 100% MPE and 100% RT on valves for rating above ANSI Class 900 and below Class 4500

In the above NDTs, MPE may be replaced by DPT for austenitic steels.

- vii) Weld edge preparations shall be subject to MPE or DPT.
- viii) Functional testing shall be carried out on fully assembled valve to check the following:
 - a) Smooth operation
 - b) Valve travel, closing and opening time.
 - c) Current drawn by actuators.
- ix) Springs for safety valves shall be tested with suitable NDT and for spring rate.
- x) Safety and safety relief valves shall be tested for performance.

8.4.2.2 Extraction line valves

- i) Surface crack examination and hardness check shall be carried out on all hard faced surfaces and stellite surfaces, if any.
- ii) As a minimum requirement of castings for all valves on cold reheat and extraction lines shall be subjected to 100% MPE on all areas and RT on butt weld ends and change of section. For forgings minimum requirement shall be 100% UT and 100% MPE.
- iii) Bar stock for valves stem shall be subjected to UT. Finish machined valve stem shall be subjected to MPE or DPT.
- iv) Wall thickness measurement by ultrasonic for critical and highly stressed zones of the casting and forging shall be carried out.
- iv) Colour matching of the valve disc and seat to ensure required contact area shall be carried out.
- v) Hydraulic pressure tests shall be carried out on each valve to check body and bonnet strength. Seat leakage and back seat leakage test (wherever applicable) shall be carried out. Air seat leakage test shall also be carried out. Minimum test requirements of pressure shall be as per ANSI B 16.34.
- vi) Functional testing shall be carried out on each valve to check for freedom of movement, adherence to clearance, opening/ closing etc. Type tests for discharge co-efficient and pressure drop co-efficient, shall be carried out. In case the type tests have been carried out in the past and documents generated, the same shall be furnished to the purchaser for approval.



8.4.2.3 Butterfly Valves

- i) Tests shall be carried out on the materials of body, disc etc. for determination of chemical and mechanical properties.
- ii) In case of fabricated valves, the plates used for body, disc and flanges shall be subject to 100% UT.
- iii) Valve body, disc and shaft shall be checked for surface and sub-surface defects by 100% MPE.
- iv) For sea water application valves, austenitic stainless steel welds shall be subject to 100% IGC (inter-granular corrosion) test.
- v) All wetted SS 316 components shall be subject to Molybdenum check.
- vi) Stubs and driving shafts shall be tested for internal defects by ultrasonic method.
- vii) Dye penetration test shall be carried out on shafts, seat rings etc.
- viii) For fabricated components of the valves, all the longitudinal/ circumferential weld seams shall be subject to 100% RT. Further, all welds on magnetic material shall be subject to 100% MPE, and welds on non magnetic material shall be subject to 100% DPT.
- ix) Test samples for rubber seal shall be subjected to tensile and hardness test for vulcanising and after ageing. Hydraulic stability test and ozone crack resistance tests also be carried out.
- x) Valve shall be subjected to hydraulic pressure test for body and air seat leakage tests as per AWWA-C504/ BS- 5155.
- xi) Proof of design tests for valves and actuator shall be carried out as per AWWA-C504/ BS- 5155. In case the test has already been carried out on previous supplies, the contractor may submit the test certification of same for approval of purchaser.
- xii) After complete assembly each valve with actuator shall be subject to the performance test by opening and closing the valve from fully closed to fully open position and the reverse, under no flow for at least 25 cycles to check the following:
 - a) Smooth uninterrupted movement of valve.
 - b) Closing and opening time.
 - c) Current drawn by actuator.
 - d) Operation of tripping switch and position indicator.

- xiii) After assembly, one valve of each size with respective actuator shall be shop operated over the full range of movement in both the directions, with the body subjected to the full hydrostatic pressure conditions, to demonstrate that the unit is in working order without any leakage through the joints and torque switches/clutches, limit switches are operating satisfactorily. During the test, hand wheel operation, opening and closing time and current drawn shall also be checked. The test shall be conducted for three consecutive cycles with valve shaft both in vertical and horizontal planes.

8.4.3 Metallic expansion bellows

- i) Hydraulic pressure test shall be carried out on each pipe and expansion bellow.
- ii) Longitudinal butt weld on bellow shall be subject to MPE or DPT before forming and after forming.
- iii) All welds shall be subject to 100% MPE or DPT. Butt welds shall be subject to 100% RT.
- iv) All the bellows subjected to vacuum service shall be vacuum tested.
- v) The bellows shall be subjected to movement test to establish suitability to perform satisfactorily in site conditions. During this test, spring rate shall also be measured.
- vi) Life cycle test, meridional yield rupture test and squirm test to be carried out on a prototype/ expansion bellow. as per Sec. D clause 3.2 of standards of Expansion Joint Manufacturer Association (EJMA).

8.4.4 Hangers and Supports

- i) All raw materials used shall have co-related mill test certificate meeting mandatory checks of material specification.
- ii) Completed springs shall be tested for sagging test and load versus deflection test. For diameter more than 25mm, MPE shall also be carried out.
- iii) Butt welds of thickness 32mm and above shall be tested for UT, and for butt welds of thickness less than 32mm MPE shall be done. Fillet welds shall be tested for MPE.
- iv) Dampers with viscous fluids shall be checked for viscosity of liquid used, damping resistance of the damper, stiffness of the damper etc.
- v) Turn-buckle, pipe clamps and hangers of thickness greater than 25mm shall be checked by MPE or DPT on bent portions.
- vi) One hanger of each type and size shall be checked for variation in deflection and travel versus load test.



8.4.5 Thermal insulation, refractory, lagging and cladding

- i) Thermal insulation
 - a) Pre-formed fibrous pipe insulation and LRB mattresses/ sections of rock wool/ mineral wool from approved manufacturing sources conforming to and tested as per relevant standards shall be used.
 - b) For resin bonded mineral wool insulation, testing shall be carried out as per IS: 8183.
 - c) For resin bonded rock wool insulation, testing shall be carried out as per IS: 9842.
 - d) For sprayed mineral wool, testing shall be carried out as per IS: 9724.
 - e) For ceramic fibre blankets and block insulation, testing shall be carried out as per IS: 15402.
 - f) Type tests except thermal conductivity shall be regularly carried out once in three months.
 - g) Type test for thermal conductivity shall be carried out by the manufacturer minimum once in six months. Thermal conductivity (K value) shall be measured in line with IS: 3346.
 - h) Wire mesh of diameter 0.71mm (minimum) shall only be used.
- ii) Castable refractory

Fire bricks or castable refractory from approved manufacturing sources conforming to and tested as per relevant standards shall be used. Castable refractory shall have proper identification, supplier name, customer name, batch no., date, material name and net weight in kg with proper instructions for handling.
- iii) Lagging and cladding

All insulation shall be protected by means of an outer covering of aluminium sheeting conforming to ASTM B-209-1060 temper H14 from reputed manufacturer.

8.4.6 Low Pressure Piping, Valves and Fittings etc.

8.4.6.1 Pipes, fittings and mitre bends

- i) Tests shall be carried out on the materials on various components to establish their mechanical properties and chemical composition. Further, heat treatment shall be carried out for materials as required.



- ii) Dye penetration test of welds of pipes and fittings (including welds of rolled and welded pipes) shall be carried out.
- iii) All pipes and fittings shall be tested as per applicable codes/ standards at manufacturer's works.

8.4.6.2 Valves

- i) Tests shall be carried out on the materials on various components to establish their mechanical properties and chemical composition. Further, heat treatment shall be carried out for materials as required.
- ii) Shaft/ spindle of size ≥ 50 mm diameter shall be subjected to ultrasonic test.
- iii) Machined surfaces of casing, disc and shaft shall be subjected to 100% MPI or DPT as applicable.
- iv) All valves shall be hydraulically tested for body, seat and back seat (wherever provided) at 1.5 times the maximum pressure to which respective valves can be subjected during plant operation. Check valves shall also be tested for leak tightness test at 25% of the specified seat test pressure. For rubber lined valves, hydraulic test shall be carried out before rubber lining.
- v) For butterfly valves, hydraulic test, seat and disc string test and proof of design test (if not carried out earlier) shall be carried out in accordance with latest edition of AWWA-C-504 standard.
- vi) Visual and dimensional check shall be carried out for all valves as per relevant code/ approved drawing.
- vii) Functional/ operational checks for and check for smooth opening and closing of the valves shall be carried out.
- viii) Gate, globe and swing check valves
 - a) Machined surfaces of castings and butt welds shall be subjected to MPE or DPT.
 - b) Blue matching, wear travel for gates, valves, pneumatic seat leakage, reduced pressure test for check valves shall be done as per relevant standard.
- ix) Diaphragm valves
 - a) Seat leakage test for actuator operated valves, shall be done with by closing the valves with actuator.



- b) Tests on rubber parts per batch of rubber mix such as hardness, adhesion, spark test, bleed test and flex test on diaphragm, type test for diaphragm for 50,000 cycles.
- x) Cast butterfly valves
 - a) Machined surfaces of casing, disc and shaft shall be subjected to MPE or DPT.
 - b) Actuator operated valves shall be checked for seat leakage by closing the valves with actuator. Seat leakage test shall be carried out in both directions.
- xi) Fabricated butterfly valves
 - a) UT shall be carried out on plate material for body and disc.
 - b) Machined surfaces of casing, disc and shaft shall be subjected to MPE or DPT.
 - c) Butt welds of thickness above 30mm on body and disc shall be subject to 100% RT alongwith and post weld heat treatment for stress relieving.
 - d) Actuator operated valves shall be checked for seat leakage by closing the valves with actuator. Seat leakage test shall be carried out in both directions.
- xii) Dual plate check valves
 - a) Dry cycle test (spring cycle test) for one lakh cycles shall be carried out as a type test.
 - b) Machined surfaces of casing, disc and shaft shall be subjected to MPE or DPT.

8.4.6.3 Rubber lining of pipes and valves

- i) For rubber lining, the following tests shall be carried out as per IS-4682 part-I or acceptable equivalent standard:
 - a) Adhesion test
 - b) Measurement of thickness
 - c) Shore hardness test
 - d) Visual examination and spark test at 5 kV/mm of thickness



- e) Bleeding resistance test (as applicable) with keeping the sample in 33% HCl, 48% NaOH and DM water for 72 hours.
- f) Bleeding test and ozone resistance test shall be done on rubber material.
- ii) Dimensional check shall be carried out as per relevant code/ approved drawing.

8.4.6.4 Coating and wrapping of pipes

Spark test, adhesion test and material test for primer and enameled and coal tar tapes, as applicable, shall be carried out as per AWWA-C-203-91.

8.4.6.5 Rubber expansion joints

- i) Rubber compound test slab after vulcanising shall be tested for tensile strength, elongation and shore hardness. Tests on rubber compound shall also include hydro stability test as per ASTM D-3137 and ozone resistance test as per ASTM D- 380.
- ii) Fabric strength of synthetic fibre for reinforcement shall be checked, and test for rubber to fabric adhesion as per IS: 3400 or ASTM D- 413, rubber to metal adhesion as per IS 3100 or ASTM D-429 shall be carried out.
- iii) All expansion joints in assembled condition shall be subjected to vacuum test at 730 mm Hg under conditions to ensure its suitability to withstand deflection in each axial transverse and longitudinal direction. Duration of test shall be of minimum 10 minutes.
- iv) All bare bellows shall be subjected to hydraulic pressure test in normal condition at twice the design pressure for a duration of 30 minutes. Additionally, all bare bellows shall be subjected to deflection tests under pressure, pressure being raised from zero to the design value in regular steps and deflection measured at each step.
- v) All expansion joints in assembled condition alongwith control rod assembly shall be subjected to deflection test under design pressure.
- vi) Either during the hydraulic test or during the vacuum test, change in circumference at the top position of the arch shall not exceed 1.5% of measured circumference at normal position.
- vii) Twenty four (24) hours after the above tests, the permanent set (variation in dimensions with respect to its original dimension) shall be measured and recorded. The permanent set shall not be more than 0.5%.
- viii) Life cycle test and burst test shall be carried out on bellows of each type, design and size.



8.4.7 Equipment Cooling Water (ECW) System

8.4.7.1 Primary side and secondary side pumps

- i) Tests shall be carried out on the materials on various components to establish their mechanical properties and chemical composition. Further, heat treatment shall be carried out for materials of shaft and rotor.
- ii) 100% UT shall be carried out on pump shaft.
- iii) 10% RT shall be carried out for butt welds on fabricated components of thickness more than 10 mm.
- iv) 100% MPE shall be carried out on pump shaft.
- v) 100% DPT shall be carried out on welds on casing, suction bell, shaft, impeller and fabricated components.
- vi) Hydraulic test shall be carried out on casing and pressure containing fabricated parts at 1.5 times the pump shut off pressure or 2 times the working pressure whichever is higher.
- vii) Individual impellers and completed rotor assembly shall be subject to dynamic balancing test. Rotor assembly shall be subject to run out test also.
- viii) Visual check and dimensional measurement shall be carried out for all the components and completely assembled pump.
- ix) Final tests
 - a) Performance testing shall be carried out as per Hydraulic Institute Standards (HIS) on each pump to determine its characteristic curve at design speed and to ensure compliance with design requirements.
 - b) Vibration on all pumps shall be measured in transverse, horizontal and vertical direction at all measuring points.
 - c) Noise level on each pump shall be measured at a distance of 1.5 m above floor level in elevation and 1 m horizontally from the nearest surface of the equipment as per HIS.
 - d) NPSH(R) test shall be carried out on one pump at pump flows of 25%, 50%, 80%, 100% and 125% of design flow at design speed. In case, NPSH (R) test has already been carried out by the contractor for the offered frame of a pump, the test shall not be repeated and certificates of test carried out earlier shall be furnished for review of the purchaser.



- e) Complete strip down of one pump shall be done after completion of all the tests on it. The strip down shall check for the condition of bearings and problems such as internal rubbing, excessive wear.

8.4.7.2 Plate heat exchangers

- i) The material used for cover plates, heat exchange plates and tie rods shall be subject to chemical and mechanical tests on one per heat basis.
- ii) Each plate after pressing shall be subject to light box test, vacuum test or air chamber test as per manufacturer's practice.
- iii) UT shall be done for plates with thickness 25 mm or above.
- iv) DPT shall be conducted for 10% of the lot of heat exchanger plates. However, in case of any defects, entire lot shall be tested and only defect free plates shall be accepted.
- v) 100% DPT shall be conducted on all welds.
- vi) Each heat exchanger shall be subjected to hydraulic test.
- vii) Assembly fit up and dimensional checks shall be carried out for each heat exchanger.

8.4.7.3 Auto clean filters

- i) Tests shall be carried out on the materials on various components to establish their mechanical properties and chemical composition.
- ii) In case of fabricated construction, the welds shall be examined for surface defects by 100% DPT.
- iii) The body shall be subject to hydraulic test at 1.5 times the design pressure.
- iv) Pressure drop, flow and particle size tests shall be carried out for the filter assembly.

8.4.7.4 Pipes, Valves and fittings

The QA requirements for piping, valves and fittings shall be as per clause 8.4.6 of this Section.

8.5.8 EOT Cranes and Hoists

8.4.8.1 Hooks

- i) All tests including proof load test as per relevant IS shall be carried out.



- ii) MPE or DPT shall be done after proof load test.

8.4.8.2 Steels castings

Steel castings shall be subjected to DPT on machined surface.

8.4.8.3 Girders, end carriage, crab, gear-box and rope drum

- i) The plates of thickness 25mm and above for girders, end carriage, crab, gear-box and rope drum shall be ultrasonically tested.
- ii) NDT requirements on weldments shall be as follows:
 - a) Butt welds in tension : 100% RT and 100% DPT
 - b) Butt welds in compression : 10% RT and 100% DPT
 - c) Butt weld in rope drum : 100% RT and 100% DPT
 - d) Fillet welds : 10% DPT (random)

8.4.8.4 Forgings

- i) All forgings (wheel, gears, pinions, axles, hooks and hook trunion) greater than or equal to 50mm diameter or thickness shall be subjected to ultrasonic testing.
- ii) DPT or MPE shall be done after hard facing and machining.

8.4.8.5 Wire rope

Wire rope shall be tested as per relevant standard.

8.4.8.6 Reduction gear

Reduction gears shall be tested for reduction ratio, backlash and contact pattern. Gear box shall be subjected to no- load run test to check for oil leakage, temp. rise, noise and vibration.

8.4.8.7 Final testing

The cranes shall be completely assembled at shop for final testing. All tests for dimension, deflection, load, overload, hoisting motion, cross travel etc. as per IS-3177 shall be carried out at shop.



8.4.8.8 Electric hoists

All electric hoists shall be tested as per IS-3938 and chain pulley blocks shall be tested as per IS-3832.

8.4.9 Elevators

- i) Reduction gears shall be checked for reduction ratio and backlash. Run outs of wheel shafts and work shafts, tooth contact and running test shall also be carried out.
- ii) Breaking load test shall be carried out alongwith all other tests as per relevant standard for steel wire rope.
- iii) Buffer springs shall be subjected to load test as per relevant specifications.
- iv) All components prior to assembly shall be checked for dimensions.
- v) All rotating components shall be tested for dynamic balancing.
- vi) Car sling and car body in assembled condition shall be checked for position of all major components i.e. car sling, inside depth, width, height, positions of push box, indicator box lights, fans etc.
- vii) Vibration level shall be determined on work geared machine.
- viii) Mechanical balance test and determination of vibration level on lift and accessories shall be carried out.
- ix) In case the lift is provided with pressurised unit, the fan shall be dynamically balanced and complete unit shall be performance tested.

8.4.10 Air Conditioning System

8.4.10.1 Refrigerant compressor (reciprocating/ screw/ centrifugal)

- i) Hydraulic/ pneumatic test of castings for cylinder block, crank case and casings etc. shall be carried out. No leakage shall be permitted
- ii) DPT on connecting rod, piston, crankshaft, screw, impeller with shaft, vanes, crank case, cylinder and casing after machining shall be carried out.
- iii) All rotating parts of reciprocating/ screw and centrifugal compressor shall be statically and dynamically balanced to ISO 1940 Gr. 6.3.
- iv) Leak tightness and vacuum check for chilling units and compressors in assembled condition shall be carried out. No leakage shall be permitted.



- v) Performance test of assembled compressor shall be done to check for following:
 - a) Capacity test for oil pump for reciprocating compressor.
 - b) No load air run (free run) test of all types of compressors and chilling units to check FAD (free air delivery), noise, vibration and temperature rise of bearing and body.
 - c) Hydraulic/ leakage test for reciprocating compressor.
 - d) Functional run test and capacity control (for part load performance) check shall be carried out

8.4.10.2 Condenser and evaporator

- i) DPT shall be carried out on finish welds.
- ii) 10% RT of butt weld joints on shell shall be carried out.
- iii) Dimensional check including tube hole diameter, ligament pitch etc. shall be carried out.
- iv) Mock-up test for tube to tube sheet expansion shall be carried out. In case such a test is already conducted for similar tube/ tube sheet thickness and materials, record for the same shall be furnished for purchaser's review and approval.
- v) Hydraulic/ pneumatic test of shell side and tube side of condenser and evaporator as applicable shall be carried out. No leakage shall be permitted.

8.4.10.3 Vapour absorption machine (VAM)

- i) All materials used for fabrication shall be of tested quality. Mill test certificates for chemical and mechanical properties shall be furnished by the manufacturer. In absence of correlated mill test certificates, check test shall be carried out.
- ii) Tubes for heat exchangers/ vessels and interconnecting pipes shall be tested as per the requirement of relevant code/standard.
- iii) All welding shall be performed as per approved Welding Procedure Specification and IBR qualified procedure and welders.
- iv) Mock-up test for tube to tube sheet expansion shall be carried out. In case such a test is already conducted for similar tube/tube sheet thickness and materials, record for the same shall be furnished for purchaser's review.
- v) RT on butt weld joints of heat exchangers/ vessels shall be carried out as per the requirement of design code/approved drawing.



- vi) DPT on Root run after backgouging and on finished welds shall be carried out.
- vii) Vessels/ heat exchangers like high temperature and low temperature generator/ condenser/ high temperature and low temperature heat exchanger/ evaporator/ absorber shall be subjected to hydraulic pressure test and leakage test under vacuum with nitrogen gas and helium gas, both tube side and shell side as applicable for individual component prior to assembly. Helium leak test shall also be conducted on complete assembly under suitable cover to detect any leakage into the system.
- viii) The complete assembled unit shall be performance tested in shop for capacity (TR) and steam consumption at the rated conditions and part load conditions. Manufacturer shall furnish a detailed procedure along with calculation for conducting such test for approval and in case of any limitation same shall be clearly brought out in the bids. All the controls shall be tested for proper functioning during the above test.

8.4.10.4 Air handling unit (AHU)

- i) 20% DPT of welding on fan hub, blades, casing and impeller as applicable shall be carried out.
- ii) UT of fan shafts (diameter greater than or equal to 50mm) shall be carried out.
- iii) DPT of fan shafts after machining shall be carried out.
- iv) DPT of welding on shaft (in case of fabricated shaft) shall be carried out.
- v) Blower fan shall be statically and dynamically balanced to ISO 1940 Gr. 6.3.
- vi) One fan of each type and size shall be performance tested as per AMCA / IS for air flow, static pressure, speed, efficiency, power consumption, noise and vibration.
- vii) One per type of assembled AHU (AHU casing and fan assembly) shall be subject to free run test. Noise, vibration and temperature rise of bearing shall be measured during run test.
- viii) All cooling coil shall be pneumatically tested and no leakage shall be permitted.

8.4.10.5 Centrifugal pump

The QA requirements for centrifugal pumps shall be as per clause 8.4.12.2 of this Section.



8.4.10.6 Cooling towers

- i) UT of fan shaft and drive shaft (diameter greater than or equal to 50mm) shall be carried out.
- ii) DPT of fan hub and shafts shall be carried out after machining.
- iii) Colors of fills shall be as per approved data sheet.
- iv) Fan assembly shall be statically balanced.
- v) Cooling towers being supplied to site in assembled condition shall be subjected to run test at shop to measure FAD, noise and vibration. For cooling towers being supplied in knocked-down condition, these tests shall be done at site.

8.4.10.7 Fans

- i) 20% DPT of welding on fan hub, blades, casing and impeller as applicable shall be carried out.
- ii) DPT of fan shafts shall be carried out after machining.
- iii) UT of fan shafts (diameter greater than or equal to 50mm) shall be carried out.
- iv) Rotating components of all fans shall be statically and dynamically balanced to ISO-1940 Gr. 6.3.
- v) All centrifugal fans shall be subjected to run test for 4 hour or till temperature stabilization is reached. Vibration, noise level, temperature rise and current drawn shall be measured during the run test.
- vi) One fan of each type and size will be performance tested as per corresponding IS code for airflow, static pressure, total pressure, speed, efficiency, power consumption, noise, vibration and temperature rise.

8.4.10.8 Low pressure air distribution system

- i) Functional test for fire damper along with solenoid shall be done.
- ii) Prototype tests for fire resistance rating as per UL-555 of each type and size of damper shall be carried out. In case prototype tests have already been done, the contractor shall submit the test report for verification and approval.



8.4.10.9 Insulation

- i) Insulation material shall be tested for all mandatory tests only as per relevant code or standard.
- ii) Thermal conductivity tests (for thermal insulation only) shall be done once in six months for insulation material manufactured during six months period for the same density, outer diameter and thickness of material as applicable as per IS:3346 or equivalent standard.

8.4.10.10 Air filters

Pre and fine filters shall be tested for initial and final pressure drop versus flow and average synthetic dust weight arrestance as per the requirement of BS 6540 or ASHARE-52-76 or EN779.

8.4.10.11 Packaged, split and window air conditioners

- i) Compressor of packaged air conditioner (PAC) shall be tested as per relevant code/standard.
- ii) PAC shall be subjected to production routine test in accordance with IS: 8148 for the following.
 - a) General running test.
 - b) Pressure or leakage test of refrigerant.
 - c) Insulation resistance test.
 - d) High voltage test.
 - e) Performance test on one PAC of each type/size at ambient condition to check for following.
 - DBT and WBT of supply and return air.
 - Air flow
 - Current, voltage measurement and power consumption
 - Noise and vibration measurement
- iii) Manufacturer's standard test certificate or guarantee certificate shall be submitted for split and window air conditioners.

8.4.10.12 Pipes, valves and fittings

The QA requirements for piping, valves and fittings shall be as per clause 8.4.6 of this Section.



8.4.11 Ventilation System

The QA requirements for ventilation system equipments shall be same as those applicable similar equipments of air conditioning system equipments described at clause 8.4.10 of this Section.

8.4.12 Miscellaneous Items/ Equipments

8.4.12.1 Chemical dosing system

- i) Pumps of chemical doing system shall be performance tested as per relevant codes.
- ii) In case of diaphragm type of pumps, the life cycle test shall be done on pumps.
- iii) Dosing skid shall be subjected to leakage test and functional test.

8.4.12.2 Centrifugal pumps

- i) Tests shall be carried out on the materials of the pumps to establish their properties, and chemical compositions.
- ii) 100% DPT or MPE shall be carried out for the rotor and machined surfaces of casing and impellers.
- iii) UT on pump shaft (diameter greater than or equal to 50mm), MPI or DPT on pump shaft and impeller after machining shall be carried out.
- iv) All rotating components of the pumps shall be statically and dynamically balanced to ISO-1940 Gr. 6.3.
- v) Assembly fit up check, and dimensional check shall be carried out for the completed pump assembly.
- vi) Pump casings shall be subject to hydraulic test at 1.5 times the shut off pressure or 2 times the working pressure whichever is higher for a minimum duration of 30 minutes.
- vii) All pumps shall be tested at manufacturer's works for head, capacity, power and efficiency as per requirements of HIS, USA or equivalent standard.. Pump shall be given running test over the entire operating range covering from the shut-off head to the maximum flow. Acceptance shall be as per approved datasheet and HIS only.
- viii) Pumps shall be subjected to strip down examination visually to check for mechanical damages after testing at shop in case abnormal noise level and/or excessive vibration are observed during the shop test.



8.4.12.3 Blowers and exhausters

- i) Tests shall be carried out on the materials of the rotary blowers to establish their properties, and chemical compositions.
- ii) 100% DPT or MPE shall be carried out for the rotor and machined surfaces of casing and impellers.
- iii) Rotors shall be dynamically balanced.
- iv) Assembly fit up check, and dimensional check shall be carried out for the completed blower assembly.
- v) The blower casing shall be subject to hydraulic test at 1.5 times the shut off pressure or 2 times the working pressure whichever is higher.
- vi) Performance test including noise and vibration tests shall be carried out as per relevant standards and codes.

8.4.12.4 Filters and strainers

- i) Tests shall be carried out on the materials on various components to establish their mechanical properties and chemical composition.
- ii) In case of fabricated construction, the welds shall be examined for surface defects by 100% DPT.
- iii) The body shall be subject to hydraulic test at 1.5 times the design pressure.
- iv) Pressure drop, flow and particle size tests shall be carried out for the filter assembly.

8.4.12.5 Tanks and vessels

- i) Tests shall be carried out on the materials on various components to establish their mechanical properties and chemical composition.
- ii) UT shall be carried out on plate material used for fabrication of tanks and vessels.
- iii) Hydraulic test for pressurised vessels and water fill test for atmospheric tanks shall be carried out as per relevant standards/ codes.
- iv) Butt welds and full penetration welds shall be checked by suitable RT or UT. Fillet welds shall be checked by MPE or DPT.

8.4.12.6 Lube oil system/ hydraulic power pack

Lube oil system/ hydraulic power pack shall be tested for performance.



8.5 FIELD ERECTION CHECKS AND TESTS

The QA requirements for raw materials, in-process tests and NDTs indicated for shop manufacture shall be applicable for site fabrication/erection of the respective item.

8.5.1 Hydraulic Test of Pressure Parts

On completion of erection of pressure parts of each steam generator, the unit with its fittings and mountings in position shall be subjected to hydraulic test pressure in accordance with requirement of Indian Boiler Regulations. Water used for hydraulic test shall be made alkaline by addition of suitable chemical. After the test, all parts shall be drained and suitably preserved.

8.5.2 Turbine Assembly

Bidder shall clearly indicate the extent of assembly to be carried out at site for steam turbine and BFP drive turbine(s). Accordingly, bidder shall submit elaborate erection and assembly inspection programme of turbines for purchaser's approval.

8.5.3 Condenser Assembly

- i) If the condenser sections calls for site assembly, care shall be taken in assembly of sections and correctness of alignment and fit up shall be checked. Site welding shall be carried out as per the procedure approved by the purchaser.
- ii) All weld seams shall be subjected to magnetic particle examination. At least 10% of butt welds shall be subjected to radiographic examination.
- iii) All welds between condenser neck and LP turbine shall be subjected to 100% radiographic and magnetic particle examination.
- iv) Condenser tubes shall be visually examined for dents, mechanical damages or any other defects prior to insertion. Both tube ends shall be thoroughly cleaned to a length of 100mm to remove oil, grease etc. and shall be checked for freedom from burrs prior to insertion.
- v) Tube expansion shall be carried out by electronic automatic torque control expanding unit, which shall be calibrated before use. Tube wall thinning and length of expansion shall be controlled and recorded.
- vi) Hydrostatic testing of condenser steam space shall be carried out after connecting all the pipes with the condenser along with condenser vacuum systems by filling the steam space with water upto the tip of the last stages of blades of LP cylinder.
- vii) Condenser water boxes shall be tested hydraulically at a minimum test pressure of 1.5 times the design pressure.



8.5.4 General

- i) All rotating equipments shall be checked for their direction of rotation and free movement after placing on the respective foundations.
- ii) Piping system shall be tested hydraulically or pneumatically as per application requirement.
- iii) All valves shall be checked for their direction of flow.
- iv) Insulation shall be carried out only after satisfactory inspection of leak test.
- v) After complete installation of air conditioning and ventilation systems, all ducting system shall be tested for air leakage test or smoke tightness test.



8.6 ELECTRICAL SYSTEMS

i) Quality Plan

The indicative list of various tests/ checks for various equipments/ items is given below. The bidder shall draw his own quality plans in line with these requirements, his standard practices and requirements of standards/ codes and implement such programme after approval by the purchaser.

ii) Process checks

Under the 'Process checks', tests which are required to be conducted at works during various stages of manufacturing have been listed.

iii) Type tests

Type tests have been divided into following two categories:

(a) Category-I

The contractor shall carry out type tests listed under Category -I for the respective equipment. The charges for each of these type tests shall be indicated separately and the same shall be considered for the evaluation of the bids. The owner reserves the right to waive conducting of any or all of the specified type tests on submission of type test report conducted on similar equipment during last five (5) years, in which case the type test charges shall not be payable for the type tests which are waived. The type test charges shall be paid only for the test(s) actually conducted successfully under this contract.

(b) Category-II

The contractor shall only submit the reports of the type tests listed under Category -II for the respective equipment which should have been carried out within last five (5) years from the date of bid opening. These reports should be for the tests conducted on the equipment similar to those proposed to be supplied under this contract and the test(s) should have been either conducted at an independent laboratory or should have been witnessed by a client. In case the contractor is not able to submit report of the type test(s) conducted within last five years from the date of bid opening, or in case the type test report(s) are not found to be meeting the specification requirements, the contractor shall conduct all such tests under this contract free of cost and submit the reports for approval.

iv) Site Tests

Some site tests have also been identified below which shall be carried out by the contractor. The site tests as per the manufacturer's practice, other than those specified herein, shall also be conducted by the bidder :-



8.6.1 Generator and auxiliary systems													
8.6.1.1 Process check for static parts of generator/ exciter													
Items/ Components/ Process	Tests/ Checks												
	Visual, dimension	Chemical property (raw material)	Heat treatment	Mechanical property (raw material)	Impact (raw material)	Hydraulic test	Pneumatic test	RT or UT (10% for butt weld)	MP or DPT (All welds)	Relative permeability	Ferrite content	DIN 43760, IS:2848,7358	DIN 48124
Sheet and Fabrication :													
- END shield	Y	Y	Y	Y	Y	Y	Y	Y	Y				
- Stator casing	Y	Y	Y	Y	Y	Y	Y	Y	Y				
- Bushing boxes	Y	Y	Y	Y	Y	Y	Y	Y	Y				
- Terminal plates	Y	Y	Y	Y	Y	Y	Y		Y				
- Manhole and covers	Y	Y	Y	Y	Y	Y	Y		Y				
- Trunnions	Y	Y	Y	Y	Y			Y	Y				
- Core bar	Y	Y		Y									
- Press ring	Y	Y		Y					Y				
- Core bolt (insulated)	Y	Y		Y				Y	Y				
- Gaskets	Y			Y									
- Bearing seals and hydrogen seals	Y	Y		Y				Y1					
- Terminal bushing													Y
- RTD/ Thermocouple												Y	
Additional check for nonmagnetic components										Y			
Non magnetic components welding											Y		
Y=Test applicable, Y1=UT on babbitt for bearing													



8.6.1.2 Process check for core of generator/ exciter		(Table 1/2)						
Items/ Components/ Process	Tests/ Checks							
	Specific loss before and after ageing	Magnetisation	Anotrophy of losses	Stacking factor	Burr level	Check for varnish, insulation (chemical, electrical, viscosity, cure time, solid content, dielectric properties)	Dimension and surface (uniformity of varnish coat	Spot weld check
Core lamination	Y	Y	Y	Y		Y	Y	
After punching insulated core laminations				Y	Y	Y	Y	
Ventilation stamping								Y
Core assembly							Y1	
Y = Test applicable, Y1 = Visual checks								

8.6.1.2 Process check for core of generator/ exciter		(Table 2/2)				
Items/ Components/ Process	Tests/ Checks					
	Process check including heating and pressure application	Insulation test of core tension bolt and core bar	Functional check of ventilation ducts	Hot spot by infra red camera, ELCID	Location of temperature detectors	Iron loss at rated flux density
Core assembly (additional checks for generator)	Y	Y	Y	Y	Y	Y
Y = Test applicable, Y1 = Visual check						



8.6.1.3 Process check for stator conductor and winding of generator/ exciter (Table 1/3)												
	Tests/ Checks											
	Mechanical Properties (sample)	Chemical Properties (sample)	Resistivity/ Resistance	Metallography properties	Eddy current and pressure test	Insulation adhesion	Flexibility of bending	Dielectric test	Dimension/ visual	Electric test	Physical properties	Brazing procedure
Winding copper and connecting busbars	Y	Y	Y	Y	Y1							
Insulated conductor						Y	Y	Y	Y			
Insulation material	Y	Y							Y	Y	Y	
Manufacturing winding bar and phase bar								Y	Y	Y		Y
Winding laying								Y	Y	Y		
Water supply hoses	Y	Y						Y	Y			
Winding support ring		Y							Y		Y	
Connection between bars												Y
Wound stator												
Y = Test applicable, Y1 = Visual checks												



8.6.1.3 Process check for stator conductor and winding of generator/ exciter (Table 2/3)					
Items/ Components / Process	Tests/ Checks				
	X-Ray	Process check	Flow test	Helium leak test and pressure test	Check on RTD and location
Winding copper and connecting busbars					
Insulated conductor					
Insulation material					
Manufacturing winding bar and phase bar	Y1	Y	Y1	Y	
Winding laying		Y			Y
Water supply hoses				Y	
Winding support ring					
Connection between bars					
Wound stator				Y1	
Y = Test applicable, Y1 = Visual checks					

8.6.1.3 Process check for stator conductor and winding of generator/ exciter (Table 3/3)										
Items/ Components/ Process	Tests/ Checks									
	Tan delta and delta (tan delta upto 1.2 Un)	Corona protection resistance	Reactance of stator winding	Magnetic permeability of metallic parts	Magnetic test and Vibration fatigue	Dielectric test at elevated, room temperature	Inter strand Insulation test	Thermal shock and boroscopic examination of brazed water box	Slot wedge tightness and radial movement	Type test on two bars for heating cycle test, Thermal stability test, Voltage endurance test
Winding copper and connecting bus bars										
Insulated conductor						Y				
Insulation material										
Manufacturing winding bar and phase bar	Y	Y					Y	Y1	Y	
Winding laying	Y									Y
Water supply hoses				Y	Y					Y
Winding support ring										
Connection between bars							Y			
Wound stator	Y		Y					Y		
Y = Test applicable, Y1= Applicable for hollow conductor										



8.6.1.4 Process check for rotor and assembly of generator / exciter		(Table 1/4)											
Items/ Components/ Process	Tests/ Checks												
	Sample tensile stress	Sample 0.2 limit	Sample elongation	Hardness on sample	Impact and stress rupture properties check on sample	Sample chemical properties	NDTT, FATT	Process check including heat treatment (as applicable)	Ultrasonic test/ RT (at suppliers works and after preliminary machining)	Sulphur prints check flux carrying capacity/ magnetic properties	Flux carrying capacity/ magnetic properties	Boroscopic examination	
Rotor forging and slip ring shaft	Y	Y	Y	Y	Y	Y	Y	Y	Y	Y	Y	Y	
Rotor end retaining ring and cover, locking ring and slip ring forgings, diode wheel	Y	Y	Y		Y	Y		Y	Y				
Rotor winding copper rotor wedges, damper wedges, CC-bolts and D-leads	Y		Y			Y		Y	Y				
Rotor slot boxes/ insulating material						Y							
Coil manufacture													
Rotor winding								Y					
Winding connection studs and assembly													
Complete rotor								Y					
Test on completed rotor at various speed upto rated speed													
Test on completed rotor before and after overspeed													
Fan hubs/ blades						Y		Y	Y				
Generator assembly													
Rectifier wheel	Y		Y					Y	Y				
Permanent magnet					Y						Y		
Exciter assembly													
Y = Test applicable													



8.6.1.4 Process check for rotor and assembly of generator / exciter		(Table 2/4)										
Items/ Components/ Process	Tests/ Checks											
	MPI or DP, NDT	Visual, dimension, cleanliness	Adhesion, thickness of coat on silver plating	Electrical conductivity and oxygen content	Mechanical test on sample	Electrical test	Resistance measurement	Purge test on vents	Helium leak test for H ₂ cooled machine	Inter-turn test	Dielectric test	Gas tightness
Rotor forging and slip ring shaft	Y	Y										
Rotor end retaining ring and cover, locking ring and slip ring forgings, diode wheel	Y		Y									
Rotor winding copper rotor wedges, damper wedges, CC-bolts and D-leads	Y		Y	Y	Y	Y						
Rotor slot boxes/ insulating material					Y	Y						
Coil manufacture		Y										
Rotor winding	Y	Y				Y	Y	Y	Y	Y	Y	
Winding connection studs and assembly	Y				Y						Y	Y
Complete rotor							Y				Y	
Test on completed rotor at various speed upto rated speed							Y			Y	Y1	
Test on completed rotor before and after over-speed		Y								Y	Y	
Fan hubs/ blades	Y	Y										
Generator assembly		Y										
Rectifier wheel		Y										
Permanent magnet		Y			Y							
Exciter assembly		Y										

Y=Test applicable, Y1= at rated speed only



8.6.1.4 Process check for rotor and assembly of generator / exciter (Table 3/4)

Items/ Components/ Process	Tests/ Checks											
	Insulation Resistance	PI at 5 kV	Radial run out/ alignment	Impedance measurement/ Repetitive Surge Oscillograph	Dynamic balancing ISO 5393, 5406, 2372, 1940 including Air run test	Over speed test (120%) for 2 minute	Functional test	Axial run out, seal ring holder	Metallography examination	Torque on joint bolts	Fitting and locking of balancing weights	Brazer and brazing procedure
Rotor forging and slip ring shaft								Y				
Rotor end retaining ring and cover, locking ring and slip ring forgings, diode wheel												
Rotor winding copper rotor wedges, damper wedges, CC-bolts and D-leads									Y			
Rotor slot boxes/ insulating material												
Coil manufacture												Y
Rotor winding												Y
Winding connection studs and assembly	Y											
Complete rotor	Y	Y	Y	Y	Y	Y			Y			
Test on completed rotor at various speed upto rated speed				Y								
Test on completed rotor before and after over-speed	Y		Y	Y								
Fan hubs/ blades											Y	
Generator assembly	Y	Y	Y				Y	Y	Y	Y	Y	Y
Rectifier wheel			Y					Y	Y	Y		
Permanent magnet												
Exciter assembly			Y				Y		Y	Y		
Y=Test applicable												



8.6.1.4 Process check for rotor and assembly of generator/ exciter (Table 4/4)
(additional checks for exciter)

Item/ Components/ Process	Tests/ Checks								
	As per IEC-146	As per IEC-76	Pole parallelism and polarity	Mechanical chemical and Magnetic properties	Functional check	Insulation resistance	IEEE/ANSI-C37.18	As per specification	Dimensional and visual
Fuse diode and filter Circuit	Y								Y
PMG and exciter stator			Y	Y		Y			
Banding wire				Y					
Exciter field Breaker, field discharge resistor					Y				
Bearing, exciter armature field, axis coil RTD						Y			
Voltage Regulator								Y	
Y = Test applicable									



8.6.1.5 Final acceptance tests for generator/ exciter		(Table 1/3)									
Item/ Components/ Process	Tests/ Checks										
	Gas tightness for H ₂ cooled machine	Resistance measurement	Rotor impedance at various speeds	Heat run test	Function check	Voltage regulation	OCC	SCC	Record auxiliary parameters	Steady state reactance	Efficiency by separation of losses
Works tests on running generator	Y	Y	Y	Y			Y	Y	Y	Y	Y
Without Excitation, OC and SC with rated voltage and current for generator				Y							
On total winding/ phases at interval 0.2Un for generator											
Condition after dismantling											
Works tests on brushless exciter		Y		Y			Y				
PMG works tests		Y		Y		Y					
Full load for PMG and converter assembly				Y							
Converter assembly				Y							
Y = Test applicable											



8.6.1.5 Final acceptance tests for generator / exciter		(Table 2/3)									
Item/ Components/ Process	Tests/ Checks										
	Insulation resistance at 5 kV	Polarization index at 5 kV	Phase sequence voltage balance	Shaft voltage and current	HV test (except electronic circuit)	RTD, BTD Check	Capacitance measurement	Tan delta, delta tan-delta	Rotor journal	Bearing oil catcher	
Works tests on running generator	Y	Y	Y	Y	Y	Y	Y	Y			
Without Excitation, OC and SC with rated voltage and current for generator											
On total winding/ phases at interval 0.2Un for generator							Y	Y			
Condition after dismantling									Y	Y	
Works tests on brushless exciter	Y				Y						
PMG works tests	Y		Y		Y						
Full load for PMG and converter assembly											
Converter assembly	Y				Y						
Y = Test applicable											

8.6.1.5 Final acceptance tests for generator/ exciter		(Table 3/3)								
Item/ Components/ Process	Tests/ Checks									
	Seal rings, liners	Winding overhang	Vibration measurement	Reduced voltage running and No load	Load characteristics	Characteristics of search coil, quadrature axis	Ripple content	Visual and dimension	Partial discharge, DLA	Routine tests as per IS/ IEC
Works tests on running generator			Y					Y	Y	Y
Without Excitation, OC and SC with rated voltage and current for generator										
On total winding/ phases at interval 0.2Un for generator										
Condition after dismantling	Y	Y								
Works tests on brushless exciter			Y	Y	Y	Y		Y		
PMG works tests				Y	Y					
Full load for PMG and converter assembly										
Converter assembly										
Y =Test applicable										

Note	
1)	All generators shall be assembled at works and shall be tested to verify/ ensure design and workmanship in accordance with IEC-34, VDE-0530, IEEE-115, IEEE 43. The manufacturer shall submit detailed test procedure which clearly specify test set up, instruments to be used, acceptance norms (wherever applicable), recording of different parameter, interval of recording, precautions, etc.



8.6.1.6 Type tests

8.6.1.6.1 Type tests (Category-I)

i) Generator

One number assembled generator shall be tested at works as per IEC-34. The tests shall be carried out keeping all conditions/ parameters as close as possible to site conditions with all the built-in instrumentation (like RTD etc.) suitably wired and the readings recorded. During various tests, bearing and shaft overhang vibrations shall also be measured with and without excitation. Recording of various parameters of bearing, seal oil system, gas system, stator water cooling system and environmental conditions (like temperature etc.) shall also be done. The following tests shall be conducted:

- a) Instantaneous short circuit test to determine transient and sub-transient reactance parameters and to ensure stability of winding during sudden short circuit condition
- b) Negative sequence and zero sequence impedance
- c) Voltage waveform factor and Total Harmonic Factor
- d) Short circuit heat run test at rated pressure and cooling parameters with one cooler out of circuit at two third of rated stator current. In case of unsymmetrical cooler configuration, test with all possible variants of one cooler out of circuit shall be carried out.
- e) Vibration measurement on all planes on stator overhang winding at suitable locations on each end and at other critical locations to be decided by purchaser for the following conditions:
 - Open circuit operation
 - Short circuit operation
 - Sudden short circuit conditions
 - Stand still condition - with Hammer test

ii) Brushless excitation system

- a) Exciter - Temperature rise test at peak rating of excitation system. Ceiling duty condition shall also be demonstrated
- b) Permanent magnet generator - Temperature rise test at peak rating of excitation system and ceiling duty condition shall also be demonstrated
- c) Converter assembly (of the exciter field) - Temperature rise test at peak rating of excitation system. Ceiling duty condition shall also be demonstrated



8.6.1.6.2 Type test (Category-II)

Brushless excitation system

- a) Converter assembly of the exciter field
 - Input and output surge withstand capability test
 - Soak test for Electronic module
- b) Degree of protection test for Excitation system panels

8.6.1.7 Site tests

The tests to be conducted on each generator at site shall include but not be limited to those listed below. Any other test considered necessary by the contractor shall also be carried out :

- a) Electrical
 - i) Measurement of the insulation resistance of the stator and rotor windings to the frame and between phases, after drying out the machine and measurement of the polarisation index
 - ii) Measurement of the DC resistance of all windings and embedded temperature detectors
 - iii) Measurement of the insulation resistance of bearings
 - iv) Capacitance measurement and dissipation factor between the winding and body
 - v) Open circuit and short circuit tests
 - vi) Measurement of temperature rise at the rated load
 - vii) Performance capability of the machine
 - viii) Line charging capacity
 - ix) Short circuit tests on the generator HV end and the generator transformer HV end to check the stability and operation of the generator and the overall (i.e. generator and generator transformer) differential protections and negative phase sequence protection.
- b) Mechanical
 - i) Hydrogen leakage test
 - ii) Vibration test
 - iii) Over-speed test
 - iv) Hydraulic tests on coolers
 - v) Bearing and shaft current test
- c) Load throw-off tests.



8.6.2 Generator Isolated Phase Busducts and Neutral Grounding equipment										
8.6.2.1 Generator Isolated Phase Busduct (Table 1/2)										
Items/ Components/ Sub-systems	Tests/ Checks									
	Visual and Dimensional Checks	Electrical/ Mechanical/ Chemical Properties	WPS and PQR	NDT, DP or MPI, RT	Painting shade and adhesion test	Galvanizing test as per IS: 2629/ 2633/ 6745	Electrical clearance and Creepage	Functional/ Operational check	Make, Type, Rating, Model, TC, General physical inspection	Routine test as per relevant standard
Enclosure/ cubicle	Y	Y		Y	Y					
Busbar flexible connector and dis-connector link	Y	Y								
Galvanized steel structure and plate	Y					Y				
Seal of bushing and post insulator IS:5621, 2544	Y	Y					Y		Y	Y
Welding of enclosure and conductor	Y		Y	Y						
Gasket, silicagel breather, CT, VT, surge capacitor and arrester, NGT, NGR, elastomer spring head								Y	Y	Y
Busbar pressurisation system	Y							Y		
Complete busduct IS:8084	Y				Y					Y
Y =Test applicable										

8.6.2 Generator Isolated Phase Bus ducts and Neutral Grounding equipment					
8.6.2.1 Generator Isolated Phase Bus duct (Table 2/2)					
Items/ Components/ Sub-systems	Tests/ Checks				
	Trial assembly at works : Heat run test and Milli volt drop measurement across bolted flexible joints	Trial assembly at works : Short circuit withstand test	Trial assembly at works: Impulse withstand test	Trial assembly at works: one minute high voltage power frequency withstand test	Trial assembly at works: Air leakage rate and water tightness test
Enclosure/ cubicle					
Busbar flexible connector and disconnector link					
Galvanized steel structure and plate					
Seal of bushing and post insulator IS:5621, 2544					
Welding of enclosure and conductor					
Gasket, silicagel breather, CT, VT, surge capacitor and arrester, NGT, NGR, elastomer spring head					
Busbar pressurisation system					
Complete busduct IS:8084	Y	Y	Y	Y	Y
Y =Test applicable					
Note					
Trial assembly set-up shall include 3-phase straight run, 90 ⁰ bend, set of flexible connection of each type, metallic bellow on enclosure, CTs mounted in position (as applicable), bolted link and necessary inspection covers.					



8.6.2 Generator Isolated Phase Bus ducts and Neutral Grounding equipment											
8.6.2.2 Neutral Grounding Resistor											
Items/ Components/ Sub-systems	Tests/ Checks										
	Visual and Dimensional check	Mechanical properties	Electrical strength	Chemical Composition	Make, Type, Rating, Model, TC, General physical inspection.	Insulation resistance measurement before and after HV Test	HV Test	Degree of protection test	Routine test as per relevant standard	Galvanizing test	Routine test
Resistor	Y	Y	Y	Y		Y					
Cubicle	Y		Y					Y			
Galvanized steel structures (IS:2633/ 2629/ 6745/ 2062)	Y									Y	
Bushing/ Post and support Insulator (IS:2544/ 5621)	Y	Y	Y		Y				Y		
Complete NGR (IEEE-32)	Y					Y	Y	Y	Y		Y
Y =Test applicable											

8.6.2.3 Type Tests

8.6.2.3.1 Type test (Category-I)

The following type tests shall be conducted on one bus-ducts of each rating:

- Heat run test (the set up shall include 3 phase straight run, 90⁰ bend, set of flexible connection of each type, metallic bellow on enclosure, CT's mounted in position, (as applicable), bolted link, and necessary inspection covers. Milli-volt drop across bolted flexible joint shall be measured)
- Short circuit withstand test (set up same as for heat run)
- Impulse withstand test (set up shall include typical X-section with flexible connections, 90⁰ bend, CT's in position, seal off bushing, inspection cover and bellows)



- d) One minute high voltage power frequency withstand test (set up as for short circuit test)
- e) Air leakage rate and water tightness test (set up shall include inspection cover, flanged joint and bellow)

8.6.2.3.2 Type test (Category-II)

- a) Panels, cubicles and marshalling boxes shall be type tested for the degree of protection provided by the enclosure as given below :
 - For 5X-it shall not be possible to insert a thin sheet of paper under gaskets and through enclosure joints.
 - For 4X-It shall not be possible to insert a one mm diameter steel wire into enclosure from any direction without force.
 - For 2X-It shall not be possible to insert a twelve (12) mm dia steel wire into the enclosure from any direction without any force.
 - Test for second digit shall be in line with IS:13947 part-1
- b) For the equipment and materials such a current transformers, voltage transformers, lightning arresters, grounding transformers, loading resistors, bushings and surge capacitors for which type test are not specified in this section, successful type tests certificate shall be submitted to the purchaser.

8.6.2.4 Site tests

- i) 10% radiography and 100% DP test on all site welded joints of busbar and enclosure
- ii) Milli-volt drop test
- iii) Ratio and polarity tests on current and voltage transformers
- iv) Insulation measurement of equipment and all wiring
- v) Functional test on pressurization (Tightness test as per ANSI 37.20)
- vi) One minute high potential power frequency withstand test at 75% of rated test voltage



8.6.3 Power Transformers														
8.6.3.1 Generator Transformers/ Unit auxiliary transformers/ Station transformers)														
(Table 1/2)														
Items/ Components/ Sub-systems	Tests/ Checks													
	Visual and dimensional checks	Mechanical properties	Electrical strength	Thermal properties	Chemical composition	Compatibility with oil	Core Loss, Hot spot	NDT, DPT or MPI, UT	Ageing test.	Voltage Ratio, Vector Group and Polarity, Magnetic Balance test	Make, Type, Rating, Model, TC, General physical inspection.	10kV Isolation test on core	WPS and PQR	Routine tests as per relevant standard
Tank	Y	Y						Y					Y	
HV and LV cable box/ Flange throat	Y	Y												
Conservator/ Radiator/ Cooler/ Pipes	Y	Y						Y						
Copper conductor (IS:191)	Y	Y	Y		Y									
Insulating material	Y	Y	Y	Y	Y	Y								
CRGO lamination and built Core	Y	Y	Y		Y	Y	Y							
Bushing/ Insulator (IS:2544/ 5621)	Y	Y												Y
Gasket	Y				Y	Y			Y					
Air Cell	Y													
Transformer oil (IS:335)														Y
On load/ off-circuit tap changer (IEC:214)	Y													Y
Core coil assembly and Pre-tanking	Y									Y		Y		
Marshalling Box	Y	Y						Y						Y
WTI, OTI, MOG, Buchholz Relay, PRD, Thermister, Breather, Terminal connector, Bushing CT, Fan and Pumps with Drives, Impact Recorder, Globe and Gate Valve, PD Detector, FRA and DGA Equipment											Y			Y
Welding (ASME Sect-IX)	Y							Y				Y		

Y = Test applicable

8.6.3.1 Generator Transformers/ Unit auxiliary transformers/ Station transformers (Table 2/2)								
Items/ Components/ Sub-systems	Tests/ Checks							
	Oil Leakage Test	Jacking test followed by DP Test on load bearing member	DGA of oil for main tank and OLTC Chamber	Measurement of capacitance and tan delta	Partial discharge measurement (long duration) as per IEC-76 clause No. 12.4	Routine Tests	Nitrogen dew point measurement before final packing for transportation to site	Paint shade thickness and adhesion and finish
Complete Transformer (IS:2026/ IEC:76)	Y	Y	Y	Y	Y	Y	Y2	Y
Y = Test applicable Y2 = Applicable only for Nitrogen filled transformer								
Notes								
Each transformer shall be completely assembled with all fittings and accessories meant for the particular transformer before offering for inspection and testing.								

8.6.3.2 Type Tests (Category-I)

i) Generator transformer

The following type tests shall be conducted on one generator transformer :

- a) Temperature rise test
- b) Tank vacuum test
- c) Tank pressure test
- d) Short circuit test: The test procedure shall be as per IEC 76-5. All type tests other than tank tests shall be conducted only after short circuit test to ensure delivery of healthy and proven transformer. The time duration for each shot during short circuit test shall be as per IEC 76-5. The

allowed variation in inductance shall be as per IEC 76-5. All dielectric routine tests shall be conducted before and after short circuit test at full value including following also:

- Dissolved gas analysis
 - Frequency response analysis
- e) Recurrence surge oscillograph measurement.
- f) Test reports for DOP test (IP 55) on cooler control cabinet (CCC)/ OCTC/ common marshalling box (CMB) shall be submitted.

ii) Station transformer and unit auxiliary transformer

The following type tests shall be conducted on one station and one unit auxiliary transformer :

- a) Temperature rise test: Temperature rise test shall be performed at a tap corresponding to maximum losses. The test shall be carried out at minimum 110% of rated current. Oil samples as per IEC-567 shall be taken before and immediately after temperature rise test. DGA shall be conducted on this oil sample and the values shall be recorded in the report. For evaluation of gas analysis in temperature rise test the procedure shall be as per IS 9434 (based on IEC 567) and results will be interpreted as per IS 10593 (based on IEC 599).
- b) Tank vacuum test
- c) Tank pressure test
- d) Lightning impulse test on HV and LV winding for station transformer and unit auxiliary transformer as per clause 14 of IEC 60076-3.
- e) Short circuit test: - The test procedure shall be as per IEC 60076-5. All type tests other than tank tests shall be conducted only after short circuit test to ensure delivery of healthy and proven transformer. All dielectric routine tests shall be conducted before and after short circuit test at full value. All dielectric routine tests shall be conducted before and after short circuit test at full value including following also:
- Dissolved gas analysis
 - Frequency response analysis
- f) Recurrence surge oscillograph measurement.
- g) The test reports for DOP test – IP55 test on CCC/ CMB/ OLTC/ OCTC cabinet shall be submitted.



iii) Special tests for Generator Transformer, Station Transformer and Unit Auxiliary Transformer

The following special tests shall be conducted on each rating of transformer

- a) Power taken by cooling equipment
- b) No load harmonic measurement
- c) Noise level measurement as per NEMA TR-1
- d) Zero sequence impedance measurement

8.6.3.3 Details of Vacuum test on transformer tank

Each transformer tank shall be subjected to the specified vacuum. The tank designed for full vacuum shall be tested at an internal pressure of 3.33 kN/ m² absolute (25 torr) for one hour. The permanent deflection of the plate after the vacuum has been released shall not exceed the values specified below:

Horizontal length of Flat Plate (mm)	Permanent deflection (mm)
Upto and including 750	5.0
751 to 1250	6.5
1251 to 1750	8.0
1751 to 2000	9.5
2001 to 2250	11.0
2251 to 2500	12.0
2501 to 3000	16.0
above 3000	19.0

8.6.3.4 Details of Pressure test on transformer tank

Transformer tank of each size shall be subjected to a pressure corresponding to twice the normal head of oil or to the normal pressure plus 35 kN/ m², whichever is lower, measured at the base of the tank and maintained for one hour. The permanent deflection of the plates after the excess pressure has been released shall not exceed the figure specified above for vacuum test.

8.6.3.5 Site tests

The following minimum tests/ checks shall be conducted at site. Any other tests/ checks as per the manufacturer's recommendation shall also be carried out

- a) Colour of silicagel in silicagel breather



- b) Oil level in the breather housing, conservator tanks, cooling system, condenser-bushing etc.
- c) Bushing for conformity of connection to the lines etc. and tan delta test for bushing
- d) Operation of protection devices and alarms:
 - Buchholz relay
 - Excessive winding temperature
 - Excessive oil temperature
 - Low oil flow
 - Low oil level indication
- e) Resistance of all windings on all steps of the tap changer. Insulation resistance of the following:
 - Control wiring
 - Cooling system motor and control
 - Main windings
 - Tap changer motor and control
 - Tank and turret mounted CTs
 - Core and clamp:
 - Core to earth
 - Core clamp to earth
 - Core to core clamp
- f) The following checks shall also be carried out:
 - Direction and overload setting of cooling accessories
 - Buchholz, oil level indicator, pressure gauges, temp indicators etc. for fitting and operation.
 - Earthing of main tank, marshaling box, tap changer driving gear, pump and fan motor etc.
 - Neutral earthing
 - Calibration of WTI and OTI
 - Earthing of bushing test tap
 - Connection of WTI CT
 - Tightness of CT secondary connection and shorting of unused CTs
 - All valves for their correct opening and close sequence
- g) Phase out and vector group test
- h) Ratio test on all taps
- i) Magnetizing current test (HV winding and LV winding)
- j) Capacitance and Tan delta measurement of winding
- k) Noise level



- l) Oil dielectric strength test- The various test on oil shall be conducted prior to filling in main tank at site and prior to energization at site. Oil samples are to be drawn from top and bottom of main tank, cooling system and OLTC.
- m) DGA of oil before commissioning
- n) Core isolation test
- o) Magnetic balance test
- p) Short circuit impedance measurement
- q) Test on tank/ turret mounted CTs
 - IR value between secondary winding & earth and between windings
 - Secondary resistance
 - Polarity
 - Ratio test
 - Magnetization current
- r) Test on cooler fan and pump
 - IR Value
 - Starting current
 - Running current
- s) WTI and OTI setting for alarm/trip, fan start/stop and pump start/stop
- t) Final IR value between windings and earth
- u) Continuously observation of the transformer operation at no load for 24 hours with respect to voltage, no load current, temperature rise and noise.
- v) Gradually put the transformer on load, check and measure increase in temperature in relation to the load and check the operation with respect to temperature rise and noise level etc.



8.6.4 HT BUSDUCT										
8.6.4.1 11kV & 3.3kV Segregated Phase Bus ducts										
Items/ Components/ Sub-systems	Tests/ Checks									
	Visual and Dimensional Checks	Electrical, Mechanical, Chemical properties	WPS and PQR	NDT, DP or MPI, RT	Paint shade and Adhesion test	Galvanizing Test as per IS: 2629/ 2633/ 6745	Electrical clearance and creepage	Functional/ Operational check	Make, Type, Rating, Model, TC, General physical inspection	Routine tests on complete busduct
Enclosure/ cubicle	Y	Y		Y	Y					
Busbar flexible connector and disconnector link	Y	Y								
Steel structure and plate IS:2062		Y				Y				
Bushing, post and support insulator (IS:9431 and 2544)	Y						Y			Y
Welding of enclosure and conductor	Y		Y							
Gasket, silicagel breather								Y	Y	Y
Complete busduct IS:8084	Y				Y					Y
Y =Test applicable										

8.6.4.2 Type test (Category-II)

- (a) All bus-ducts supplied shall be of type tested quality.
- (b) Type test reports for the following shall be submitted:
 - One minute power frequency voltage withstand test
 - Temperature rise test. Milli volt drop shall also be measured across bolted flexible joint
 - Impulse voltage withstand test
 - Short time current test
 - Water tightness test (as per IS:8084)
 - Air leakage test



8.6.4.3 Site tests

The following minimum tests/ checks shall be conducted at site. Any other tests/ checks as per the manufacturer's recommendation shall also be carried out

- Power frequency voltage withstand test
- Air leakage test
- Water tightness test on outdoor portion of bus-duct
- Insulation resistant measurement of equipment and all wiring
- Milli-volt drop



8.6.5 Auxiliary Service Transformers													
8.6.5.1 Oil-filled Outdoor Transformers													
Items/ Components/ Sub-systems	Tests/ Checks												
	Visual and Dimensional checks	Mechanical properties	Electrical strength	Thermal properties	Chemical Composition	Compatibility with oil	Core Loss (on first Job) Hot Spot	NDT, DP or MPI, UT	Ageing Test	Voltage Ratio, Vector Group and Polarity, Magnetic balance test	Make, Type, Rating, Model, TC, General physical Inspection.	WPS and PQR	Vacuum and Pressure Test
Tank, HV and LV Cable Box/ Flange throat	Y	Y						Y				Y	
Conservator/ Radiator/ Cooler/ Pipes	Y	Y						Y					
Copper Conductor (IS:191)	Y	Y	Y		Y								
Insulating Material	Y	Y	Y	Y	Y	Y							
CRGO Lamination and Built Core	Y	Y	Y		Y	Y	Y						
Bushing / Insulator (IS:2544/ 5621)	Y	Y								Y			Y
Gasket	Y				Y	Y		Y					
Transformer oil (IS:335)													Y
Off-circuit tap changer	Y									Y			
Core coil assembly and pre-tanking	Y								Y				
Marshalling box	Y	Y						Y					
WTI, OTI, MOG, PRD, Breather, Terminal Connector, Bucholz Relay, Globe and Gate Valve,	Y									Y			
Welding (ASME Sect-IX)	Y										Y		
Complete Transformer (IS:2026)	Y												Y

Y =Test applicable



8.6.5.2 Dry Type Indoor Transformers												
Items/ Components/ Sub-systems	Tests/ Checks											
	Visual and dimensional check	Mechanical properties	Electrical strength	Thermal properties	Chemical properties	Core loss (on first job), Hot Spot	NDT, DP or MPI	Voltage ratio, vector group and polarity	Make, Type, Rating, Model, TC, General physical inspection	WPS and PQR	Measurement of capacitance and tan delta between winding	Routine tests
Enclosure door, HV and LV Cable box/ Flange throat	Y	Y							Y			
Copper conductor	Y	Y	Y		Y							
Insulating material	Y			Y	Y							
CRGO lamination and built core	Y					Y						
Bushing/ Insulator (IS:2544/ 5621)	Y								Y			Y
Gasket	Y								Y			Y
Off-circuit tap changer	Y								Y			
Core coil assembly	Y							Y				
Marshalling box	Y											
WTI, Thermister, Terminal connector	Y								Y			
Welding										Y		
Complete transformer (IS:11171)	Y										Y	Y
Y =Test applicable												

8.6.5.3 Type tests

8.6.5.3.1 Type tests (Category-I)

The transformer shall be subjected to the following type tests for rating above 2 MVA.

- i) Short Circuit test – This test shall be carried out after conducting the routine tests. Rest of the type tests shall be conducted after successful short circuit testing.
- ii) Noise level measurement
- iii) Measurement of zero phase sequence impedance
- iv) Measurement of the harmonics of no load current
- v) Temperature rise
- vi) Lightning impulse voltage test on all the three limbs as per Cl. 13 of IS:2026 Part-III,1981

8.6.5.3.2 Additional Type tests (Category-I)

- i) Vacuum Test on Transformer Tank - One Transformer tank of each rating shall be subjected to the specified vacuum. The tank designed for full vacuum shall be tested at an internal pressure of 0.35 kg/ cm² (absolute, 250 mm of Hg) for one hour. The permanent deflection of flat plates after the vacuum has been released shall not exceed the values specified below :

Horizontal Length of Flat Plate (mm)	Permanent deflection (mm)
Upto and including 750	5.0
751 to 1250	6.5
1251 to 1750	8.0
1751 to 2000	9.5
2001 to 2250	11.0
2251 to 2500	12.0
2501 to 3000	16.0
Above 3000	19.0

- ii) Pressure Test on Transformer Tank - One transformer tank of each rating shall be subjected to a pressure corresponding to twice the normal pressure of normal pressure plus 0.35 kg/ cm² whichever is lower measured at the base of the tank and maintained for an hour. The permanent deflection of flat plates after the excess pressure has released shall not exceed the figure for vacuum test.
- iii) Oil Leakage Test - All tanks and oil filled compartments shall be tested for oil tightness by oil of a viscosity not greater than that of insulating oil to IS:335, at the specified ambient temperature and subjected to a pressure equal to the normal pressure plus 35 KN/ m² (51 lb/ inch²) measured at the base of the tank. This pressure shall be maintained for a period of not less than 12 hours, during which time no leakage shall occur.
- iv) Tests on associated equipments - Porcelain bushings, bushing current transformers, winding temperature indicating devices, dial thermometers, buchholz relays, ON/OFF load tap changer, auxiliary motors and motor starting contactors, coolers, control device, Insulating oil and other associated equipment shall be tested in accordance with relevant IS. The following checks shall also be made before dispatch:
- Check for proper packing and preservation of accessories like radiators, bushings, explosion vent, dehydrating breather, Buchholz relay, conservator etc.
 - Check for proper provision of bracing to arrest the movement of core and winding assembly inside the tank.
 - Test for Gas tightness and derivation of leakage rate to ensure adequate reserve gas capacity during transit and storage.

8.6.5.3.3 Type tests (Category-II)

All indoor transformers below and equal to 2 MVA rating to be supplied shall be of type tested quality. The test reports of the following type tests shall be submitted.

- i) Short Circuit test – This test shall be carried out after conducting the routine tests. Rest of the type tests shall be conducted after successful short circuit testing.
- ii) Noise level measurement
- iii) Measurement of zero phase sequence impedance
- iv) Measurement of the harmonics of no load current
- v) Temperature rise
- vi) Lightning impulse voltage test on all the three limbs as per Clause 13 of IS:2026 Part-III,1981

8.6.5.4 Site tests

- i) The following minimum tests/ checks shall be conducted at site. Any other tests/ checks as per the manufacturer's recommendation shall also be carried out
 - a) Dry out test
 - b) Resistance measurement of windings
 - c) Ratio test
 - d) Vector group test
 - e) Tap changer test
 - f) Buchholz relay test
 - g) Low oil level alarm.
 - h) Temperature indicators
 - i) Marshalling kiosk
 - j) Protective relays
 - k) Magnetizing current
- ii) The following additional checks shall be made to see the following:
 - a) All oil valves are in correct position closed or opened as required
 - b) All air pockets are cleared
 - c) Thermometer pockets are filled with oil
 - d) Oil is at correct level in the bushing, conservator, divertor switch, tank etc.
 - e) Earthing connections are made
 - f) Colour of silica gel is blue
 - g) Bushing arcing horn is set correctly
 - h) CT polarity is correct (when bushing mounted CTs are provided)



8.6.6 Motors		Tests/ Checks																
Item/ Components/ Sub-system	Visual	Dimensional	Make, Type, Rating, TC, General physical inspection	Mechanical, Chemical properties	NDT, DP or MPI, UT	Metallography	Electrical characteristics	Welding/ Brazing (WPS/ PQR)	Heat treatment	Magnetic characteristics	Hydraulic, Leak, Pressure test	Thermal characteristics	Run out	Dynamic balancing	All tests as per IS:325/ IS:4722/ IS:9283	Vibration	Over speed	Tan delta, shaft voltage and polarisation index test
Plates for stator frame, end shield, spider etc.	Y	Y	Y	Y					Y									
Shaft	Y	Y	Y	Y	Y	Y			Y									
Magnetic material	Y	Y	Y	Y	Y		Y			Y		Y						
Rotor copper/ Aluminium	Y	Y	Y	Y		Y	Y		Y									
Stator copper	Y	Y	Y	Y			Y		Y			Y						
SC ring	Y	Y	Y	Y	Y	Y	Y	Y	Y									
Insulating material	Y		Y	Y			Y					Y						
Tubes for cooler	Y	Y	Y	Y	Y				Y		Y							
Sleeve bearing	Y	Y	Y	Y	Y				Y		Y							
Stator, Rotor coils	Y	Y	Y				Y	Y										
Castings, stator frame, terminal box and bearing housing etc.	Y	Y	Y	Y	Y			Y										
Fabrication and machining of stator, rotor, terminal box	Y	Y			Y				Y									
Wound stator	Y	Y					Y	Y										



Rotor complete	Y	Y					Y						Y	Y				
Stator, Rotor, Terminal Box assembly	Y	Y					Y											
Accessories, RTD, BTD,CT, Brushes, Diodes, space heater, antifriction bearing, cable glands, lugs, gaskets etc.	Y	Y	Y															
Complete motor (IS: 325/ IS:4722/ IS:9283)	Y	Y	Y											Y	Y	Y	Y	Y ₁
Y =Test applicable, Y1 = for 11kV and 3.3kV motors only																		
Notes																		
1)	This is an indicative list of tests/ checks. The manufacture is to furnish the detailed Quality Plan indicating the practices and procedure followed along with relevant supporting documents during QP finalization. However QP approval is not envisaged for 415V motors upto 50 KW.																	

8.6.6.1 Type tests

8.6.6.1.1 Type tests (Category-I)

11kV, 3.3kV motors

The following type tests shall be conducted on each type and rating of 11kV, 3.3kV motor:

- No load saturation and loss curves upto approximately 115% of rated voltage
- Measurement of noise at no load
- Momentary overload test (subject to test bed constraint)
- Full load test
- Temperature rise test at rated conditions (During heat run test, bearing temperature, winding temperature, core temperature, coolant flow and its temperature shall also be measured. In case the temperature rise test is carried at load other than rated load, specific approval for the test method and procedure is required to be obtained. Wherever ETD's are provided, the temperature shall be measured by ETD's also for the record purpose).



- Impulse Voltage test (on the sample coil after placing it in stator core at $(4U+5kV)$ and with at least five impulse of 1.2/50 micro-second wave, for MV motors only, where U is the line to line voltage in kV).

8.6.6.1.2 Type tests (Category-II)

- i) 11kV and 3.3kV motors

The following type test reports shall be submitted for each type and rating of motor.

- Degree of protection test for the enclosure followed by IR, HV and no load run test
- Terminal box-fault level withstand test for each type of terminal box
- Type test on Elastimold termination kit as per relevant standard

- ii) 415V motors

415V motors shall be of type tested quality. The type test reports for type tests as per relevant standards shall be submitted for each type and rating of 415V motors.

8.6.6.2 Site Tests

The following minimum tests/ checks shall be conducted at site. Any other tests/ checks as per the manufacturer's recommendation shall also be carried out

- i) Measurement of vibration.
- ii) Measurement of insulation resistance and polarization index.
- iii) Measurement of full load current.
- iv) Test running of the motors, checking the temperature rise and identifying the hot spot etc.



8.6.7 11kV, 3.3kV Switchgear (Table 1/2)														
Items/ Components/ Sub-systems	Tests/ Checks													
	Make, Type, Model, Rating and TC	Electrical Properties	Mechanical properties	Chemical properties	Dimensions and Finish	Functional and operational features	Item to conform to relevant Standards	Pretreatment as per IS 6005	Paint shade, thickness, adhesion and finish	Functional Checks	HV and IR Test	Degree of Protection - Routine test	CB Operation timing check	All Routine Tests as per relevant standards
Aluminum busbar material (IS: 5082)	Y	Y	Y	Y	Y		Y							
Copper busbar material (IS :613)	Y	Y	Y	Y	Y		Y							
Bus bar support insulation (IS:9431)	Y	Y	Y		Y		Y			Y				
HT Circuit Breaker (IEC:56)	Y				Y	Y	Y			Y			Y	Y
HT Contactors (IS:9046)	Y				Y	Y	Y			Y				Y
Protection and auxiliary relays (IS:3231/ 8686)	Y				Y	Y	Y			Y				Y
HT CT's and PT's (IS:2705/ 3156)	Y				Y		Y							Y
HT Fuses (IS:9385)	Y				Y	Y	Y							
Surge arrester (IEC:99-4)	Y				Y		Y							Y
LT Contactors (IS:13947)	Y				Y	Y	Y			Y				
Control and selector switches (IS:6875)	Y				Y	Y	Y			Y				
Indicating meters (IS:1248)	Y				Y	Y	Y			Y				Y
Indicating lamps (IS:13947)	Y				Y	Y	Y			Y				
Push buttons (IS: 4794)	Y				Y	Y	Y			Y				
Control transformer (IS:12021)	Y				Y	Y	Y							Y
LT fuses (IS:13703)	Y				Y	Y	Y							
Energy meters (IS:722)	Y				Y	Y	Y							Y
Transducers (IEC:60688)	Y				Y	Y	Y							Y
Y =Test applicable														



8.6.7 11kV, 3.3kV Switchgear (Table 2/2)														
Items/ Components,/ Sub-system	Tests/ Checks													
	Make, Type, Model, Rating and TC	Electrical properties	Mechanical properties	Chemical properties	Dimensions and Finish	Functional and Operational features	Item to conform to relevant standards	Pretreatment as per IS: 6005	Paint shade, thickness, adhesion and finish	Functional checks	HV and IR Test	Degree of Protection - Routine test	CB Operation timing check	All Routine Tests as per relevant standard
Diodes	Y	Y				Y	Y			Y				
Terminal Blocks	Y	Y				Y	Y							
Synthetic Rubber Gasket (IS:11149/ 3400)	Y	Y			Y		Y							
Breaker Handling Trolley	Y				Y	Y			Y	Y				
HT Switchgear Panel (IS:3427)	Y				Y	Y	Y	Y	Y	Y	Y	Y	Y	Y
Y =Test applicable														

8.6.7.1 Type test (Category-II)

All 11kV and 3.3kV Switchgears supplied shall be of type tested quality.

- a) Type test reports for the following shall be submitted:
 - i) Circuit breaker/ circuit breaker panels, of each voltage class and current rating:
 - Short circuit duty test on circuit breaker, mounted inside the panel offered alongwith CTs, bushing and separators
 - Short time withstand test on circuit breaker, mounted inside panel offered together with CTs, bushings and separators
 - Power frequency withstand test on breaker mounted in side panel
 - Lightning impulse withstand test on breaker mounted in side panel



- Temperature rise test on breaker and panel together. For this test, the test set up shall include three panels with breakers, the test breaker and panel being placed in the Center.

The adjacent panels shall also be loaded to their rated current capacity. Alternatively the test panel may be suitably insulated at the sides, which will be adjoining to other panels in actual site configuration

- Test to verify pressure relief devices operation of the panel. This shall be done on one panel of each voltage class
 - measurement of resistance of main circuit
 - Mechanical endurance test on breaker
 - Mechanical operation test
- ii) Contactor and contactor panels of each type and rating:
- Verification of rated making and breaking capacities of the contactor
 - Short time withstand test of panel
 - Power frequency test on the contactor mounted in side panel
 - Lightning impulse voltage withstand test of the contactor mounted inside panel
 - Measurement of resistance of main circuit
 - Test to confirm coordination between fuse and contactor
- iii) Surge arrester/ lightning arrester (as applicable) of each type:
- Standard lightning impulse voltage spark-over test
 - Front of wave sparkover test (For surge arrester used alongwith motor feeder, this test shall be carried out with a voltage wave having a rate of rise of not less than 142kV/ micro-second for arrester used in 11kV system and 44kV/ micro-second for arrester used in 3.3kV system).
 - Power frequency sparkover and temporary overvoltage test
 - Residual voltage test
 - Operating duty test
 - Current impulse withstand test (long duration and high current impulse)



- Pressure relief test

iv) Short circuit withstand test of earthing device (truck/ switch)

b) Shop testing of components and bought out items

For various bought out items like CT, VT, relays, meters, surge arrestors etc for which identification can be physically verified and test certificate from manufacturer can be co-related, following shall be indicated in the QP.

- Review of manufacturer's Test Certificate (TC) as per relevant standard and compliance to requirements of this specification
- Physical check and functional/ operational check to ensure that item is fit for assembly on the switch board cubicle.

For all other items where identification has not been envisaged by manufacturers, a certificate of conformance to be obtained from manufacturer, and component identification shall be tagged as per approved drawing/ schematic. Either of the following or both shall be adopted .

- Random sample to be tested either in-house or at an independent laboratory for all tests envisaged in relevant standard.
- Physical check and functional/ operation check to ensure the item is fit for assembly on the switch board cubicle.

8.6.7.2 Site tests

The following minimum tests/ checks shall be conducted at site. Any other tests/ checks as per the manufacturer's recommendation shall also be carried out

a) General

- i) Check name plate details according to specification
- ii) Check for physical damage
- iii) Check tightness of all bolts, clamps and connecting terminals
- iv) Check earth connections
- v) Check cleanliness of insulators and bushings
- vi) Check heaters are provided
- vii) HV test on complete switchboard with CT and breaker/ contactor in position
- viii) Check all moving parts are properly lubricated
- ix) Check for alignment of busbars with the insulators to ensure alignment and fitness of insulators
- x) Check for interchangeability of breakers/ contactors
- xi) Check continuity and IR value of space heater
- xii) Check earth continuity for the complete switchgear board



- b) Circuit Breaker/ Contactors
 - i) Check alignment of trucks for free movement
 - ii) Check correct operation of shutters
 - iii) Check slow closing operation (if provided)
 - iv) Check control wiring for correctness of connections, continuity and IR values
 - v) Manual operation of breakers completely assembled
 - vi) Power closing/ opening operation, manually and electrically at extreme condition of control supply voltage
 - vii) Closing and tripping time
 - viii) Trip free and anti-pumping operation
 - ix) IR values, resistance and minimum pick up voltage of coils
 - x) Simultaneous closing of all the three phases
 - xi) Check electrical and mechanical interlocks provided
 - xii) Checks on spring charging motor, correct operation of limit switches and time of charging
 - xiii) Check SF₆ pressure/ vacuum (as applicable)
 - xiv) All functional checks

- c) Current Transformers
 - i) Insulation resistance between windings and winding terminals to body
 - ii) Polarity tests
 - iii) Ratio identification checking of all ratios on all cores by primary injection of current
 - iv) Magnetisation characteristics and secondary winding resistance
 - v) Spare CT cores to be shorted to earth

- d) Voltage Transformers
 - i) Insulation resistance test
 - ii) Ratio test on all cores
 - iii) Polarity test
 - iv) Line connections as per connection diagram

- e) Cubicle Wiring
 - i) Check all switch developments
 - ii) It should be made sure that the wiring is as per relevant drawings. All interconnections between panels shall similarly be checked
 - iii) All the wires shall be meggered to earth
 - iv) Functional checking of all control circuit e.g. closing, tripping interlock, supervision and alarm circuit including proper functioning of component/ equipment
 - v) Check terminations and connections
 - vi) Wire ducting
 - vii) Gap sealing and cable bunching



- f) Relays
 - i) Check internal wiring
 - ii) Insulation resistance between all terminals and body
 - iii) Insulation resistance between AC to DC terminals
 - iv) Check operating characteristics by secondary injection
 - v) Check minimum pick up voltage of DC coils
 - vi) Check operation of electrical/ mechanical targets
 - vii) Check CT connections with particular reference to their polarities for differential type relays
 - viii) Relay settings

- g) Meters
 - i) Insulation resistance of all insulated portions
 - ii) Check CT and VT connections with particular reference to their polarities for power type meter



8.6.8 415V Switchgear and Busduct														
8.6.8.1 415V Switchgear											(Table 1/2)			
(MCC, PCC, ACDB, DCDB, Local push button station, Local motor starters)														
Items/ Components/ Sub-system	Tests/ Checks													
	Make, Model, Type, Rating and TC	Dimensions and Finish	Electrical properties	Mechanical properties	Chemical properties	Functional and Operational features	Item to conform to relevant standards	Pretreatment as per IS 6005	Paint shade, adhesion, thickness and finish	Functional checks	Milli-volt drop Test	IR – HV – IR Test	Degree of protection Routine test	All Routine tests as per relevant standards
Sheet steel (IS:513)	Y	Y		Y	Y		Y							
Aluminum bus bar material (IS:5082)	Y	Y	Y	Y	Y		Y							
Copper bus bar material (IS:613)	Y	Y	Y	Y	Y		Y							
Support insulator (IS:943, IS:10912, IEC: 660)	Y	Y	Y	Y			Y							
Air circuit breaker (IS:13947)	Y	Y				Y	Y			Y	Y			Y
Energy meters (IS:722)	Y	Y				Y	Y			Y				Y
Power and auxiliary contactor (IS:13947)	Y	Y				Y	Y			Y				
Protection and auxiliary relays (IS:3231)	Y	Y				Y	Y			Y				Y
Control and selector switches (IS:6875)	Y	Y				Y	Y			Y				
CT and VT (IS 2705/ 3156)	Y	Y					Y							Y
MCCB (IS:13947)	Y	Y					Y			Y				
Indicating meters (IS:1248)	Y	Y				Y	Y			Y				Y
Indicating lamps (IS:13947)	Y	Y				Y	Y			Y				
Air break switches (IS:13947)	Y	Y				Y	Y			Y				
Control terminal blocks	Y	Y				Y	Y							
Y =Test applicable														



8.6.8.1 415V Switchgear														
(Table 2/2)														
(MCC, PCC, ACDB, DCDB, Local push button station, Local motor starters)														
Items/ Components/ Sub-system	Tests/ Checks													
	Make, Model, Type, Rating and TC	Dimensions and Finish	Electrical properties	Mechanical properties	Chemical properties	Functional and Operational Features	Item to conform to relevant standards	Pretreatment as per IS: 6005	Paint Shade, Adhesion, Thickness and Finish	Functional checks	Milli-volt drop Test	IR – HV – IR Test	Degree of Protection - Routine test	All Routine tests as per relevant standards and specification
Fuse (IS:13703)	Y	Y				Y	Y			Y				
Control transformer (IS:12021)	Y	Y				Y	Y			Y				Y
Push Buttons (IS:4794)	Y	Y				Y	Y			Y				
Transducer (IEC:60688)	Y	Y				Y	Y			Y				Y
MCB (IS:8828)	Y	Y				Y	Y			Y				
Breaker handling trolley	Y	Y				Y			Y	Y				Y
Synthetic rubber gasket (IS:11149)	Y	Y		Y	Y		Y							
415V Switchgear (IS:8623)	Y	Y				Y	Y	Y	Y	Y	Y	Y	Y	Y
Y =Test applicable														



8.6.8.2 415V Busduct														
Items/ Components	Tests/ Checks													
	Dimension and surface finish	Make, Type, Rating and Test certificate (TC)	Electrical properties	Mechanical properties	Chemical properties	Item to conform to relevant IS	WPS approval, Welder qualification	Weld quality check (DP test and X-ray)	Paint shade, Thickness, Adhesion and finish	Tightness by torque measurement	Electrical clearances	Galvanizing test as per IS 2629/ 2633	IR – HV – IR test	Phase sequence check
Aluminum sheets/ plates/ strips / flexibles/ tubes (IS:5082/ 737)	Y	Y		Y	Y	Y	Y	Y						
CRCA flats/ ISMC (IS:2062)	Y	Y		Y	Y	Y								
Neoprene/ synthetic rubber gaskets (IS:11149/ 3400)	Y	Y		Y	Y									
Rubber bellows (IS:3400)	Y	Y		Y	Y									
Support insulator (BS:2782, IEC:660, IS:10912)	Y	Y	Y	Y										
Galvanized structure and GI earthing flat (IS:2629/ 2633/ 4749)	Y	Y				Y					Y			
Space heater and Thermostat		Y	Y											
LT busduct (IS:8623 Part 2)	Y	Y				Y	Y	Y	Y	Y		Y	Y	Y
Y = Test applicable														



8.6.8.3 Type test (Category-II)

All 415V Switchgears and bus duct supplied shall be of type tested quality.

- a) Type test reports for the following tests shall be submitted on each type and rating of 415V switchgear and AC, DC distribution boards:
 - i) Short time withstand test with circuit breaker mounted inside the switchgear panel
 - ii) Temperature rise test
 - iii) Type II - Short circuit co-ordination test for any three ratings of MCC module
 - iv) Test sequence-1 and combined test sequence shall be carried out on each rating of circuit breaker mounted inside the panel
 - v) Degree of protection test
- b) Type test reports for the following tests shall be submitted on each type and rating of 415V bus duct:
 - i) Heat run test on an assembly of representative sections and fittings
 - ii) Short circuit test for a duration and current on an assembly of representative section
 - iii) One minute high potential power frequency voltage withstand test
 - iv) Air and water tightness test on a typical section

8.6.8.4 Site tests

The following minimum tests/ checks shall be conducted at site. Any other tests/ checks as per the manufacturer's recommendation shall also be carried out

- a) General
 - i) Check name plate details according to specification
 - ii) Check for physical damage
 - iii) Check tightness of all bolts, clamps and connecting terminals
 - iv) Check earth connections
 - v) Check cleanliness of insulators and bushings
 - vi) Check heaters are provided
 - vii) HV test on complete switchboard with CT and breaker/ contactor in position
 - viii) Check all moving parts are properly lubricated



- ix) Check for alignment of busbars with the insulators to ensure alignment and fitness of insulators
 - x) Check for interchange ability of breakers/ contactors
 - xi) Check continuity and IR value of space heater
 - xii) Check earth continuity for the complete switchgear board
- b) Circuit Breaker/ Contactors
- i) Check alignment of trucks for free movement
 - ii) Check correct operation of shutters
 - iii) Check slow closing operation (if provided)
 - iv) Check control wiring for correctness of connections, continuity and IR values
 - v) Manual operation of breakers completely assembled
 - vi) Power closing/ opening operation, manually and electrically at extreme condition of control supply voltage
 - vii) Closing and tripping time
 - viii) Trip free and anti-pumping operation
 - ix) IR values, resistance and minimum pick up voltage of coils
 - x) Simultaneous closing of all the three phases
 - xi) Check electrical and mechanical interlocks provided
 - xii) Checks on spring charging motor, correct operation of limit switches and time of charging
 - xiii) Check SF₆ pressure/ vacuum (as applicable)
 - xiv) All functional checks
- c) Current Transformers
- i) Insulation resistance between windings and winding terminals to body
 - ii) Polarity tests
 - iii) Ratio identification checking of all ratios on all cores by primary injection of current
 - iv) Magnetisation characteristics and secondary winding resistance
 - v) Spare CT cores, if any to be shorted and earthed
- d) Voltage Transformers
- i) Insulation resistance test
 - ii) Ratio test on all cores
 - iii) Polarity test
 - iv) Line connections as per connection diagram
- e) Cubicle Wiring
- i) Check all switch developments
 - ii) It should be made sure that the wiring is as per relevant drawings. All interconnections between panels shall similarly be checked
 - iii) Insulation resistance of all wires with respect to earth



- iv) Functional checking of all control circuit e.g. closing, tripping interlock, supervision and alarm circuit including proper functioning of component/ equipment
- v) Check terminations and connections
- vi) Wire ducting
- vii) Gap sealing and cable bunching

- f) Relays
 - i) Check internal wiring
 - ii) Insulation resistance between all terminals and body
 - iii) Insulation resistance between AC and DC terminals
 - iv) Check operating characteristics by secondary injection
 - v) Check minimum pick up voltage of DC coils
 - vi) Check operation of electrical/ mechanical targets
 - vii) Check CT connections with particular reference to their polarities for differential type relays
 - viii) Relay settings

- g) Meters
 - i) Insulation resistance of all insulated portions
 - ii) Check CT and VT connections with particular reference to their polarities for power type meter

- h) Bus duct
 - i) Visual inspection
 - ii) Power frequency voltage withstand test
 - iii) Insulation resistant measurement of equipment and all wiring
 - iv) Milli-volt drop



8.6.9 Power and Control Cables :														
8.6.9.1 11kV, 3.3kV Power Cables											(Table 1/2)			
Item/ Components/ Sub-system	Tests/ Checks													
	Make, Type, Rating and TC	Dimension/ surface finish	Mechanical properties	Chemical composition	Spark test	Curing properties	Electrical properties	Hot set test, Eccentricity and Ovality	Lay length and sequence	Armour coverage, cross over, looseness, gap between two wire	Sequential marking/ surface finish/ cable length	Tensile strength and elongation before and after ageing on outer sheath and insulation	Thermal stability on outer sheath	Metallic screening (if applicable)
Aluminium (IS-8130)	Y	Y	Y	Y			Y							
Semi conducting compound	Y		Y			Y	Y							
XLPE compound (IS-7098- Part-II)	Y		Y			Y	Y					Y		
FRLS PVC compound (IS-5831, ASTM-D2843, ASTM-2863, IEC-754 Part-1)	Y		Y									Y	Y	
Triple extrusion and curing/ Manufacturing of core		Y			Y			Y	Y					
Copper tape	Y	Y	Y				Y							
Polyster tape	Y	Y												
Armour wire/strip	Y	Y	Y											
Copper tapping	Y	Y						Y						
Inner sheath	Y	Y												
Armouring										Y				Y
Outer sheathing		Y									Y	Y	Y	
Power cable (Finished) (IS : 7098 Part-II) IEC:332, IS-5831, ASTM-D2843, ASTM-2863,IEC-754 Part-1)	Y								Y	Y	Y	Y	Y	
Wooden drum(IS:10418)/ Steel drum		Y												

Y =Test applicable



8.6.9.1 11kV, 3.3kV Power cables		(Table 2/2)			
Item/ Components/ Sub-system	Tests/ Checks				
	Anti termite coating on wooden drums	Constructional requirements feature as per specification	Routine and acceptance test as per relevant standard and specification	FRLS tests	
Aluminium (IS-8130)					
Semi conducting compound					
XLPE compound (IS-7098- Part-II)					
FRLS PVC compound (IS-5831, ASTM-D2843, ASTM-2863, IEC-754 Part-1)				Y	
Triple extrusion and curing/ Manufacturing of core					
Copper tape					
Polyster tape					
Armour wire/strip					
Copper tapping					
Inner sheath					
Armouring					
Outer sheathing		Y		Y	
Power cable (Finished) (IS : 7098 Part-II) IEC: 332, IS-5831, ASTM-D2843, ASTM-2863, IEC-754 Part-1)		Y	Y	Y	
Wooden drum(IS-10418) /Steel Drum	Y				
Y =Test applicable					
Notes					
1)	Additional acceptance tests like FRLS, thermal stability, tensile strength and elongation after ageing shall be done on one sample/ lot				
2)	Length measurement/ surface finish/ eccentricity/ ovality shall be checked on one length/ size/ lot				
3)	Routine test shall be carried out on each drum length as per specifications.				



8.6.9.2 1.1 kV PVC and XLPE cables		(Table 1/2)										
Item/ Components/ Sub-system	Tests/ Checks											
	Make, Rating, Type and TC	Dimension/surface finish	Mechanical properties	Chemical composition	Electrical properties	Spark test	Hot set test (XLPE)	Lay length/ sequence	Armour coverage, cross over, looseness, Gap between two armour wire/ strip	Sequential marking/ surface finish/ cable length	Tensile strength, elongation before and after ageing of insulation and outer sheath	Thermal stability of insulation and outer sheath *
Aluminum (IS-8130)	Y	Y	Y	Y	Y							
PVC compound (IS-5831)	Y		Y		Y						Y	
XLPE compound (IS-7098 Pt-I)	Y		Y		Y		Y				Y	
FRLS PVC compound (IS-5831) ASTM-D-2843/ ASTM-D-2863 IEC-754 Part-I	Y		Y								Y	
Armour wire/strip (IS-3975)	Y	Y	Y									
Insulated core		Y				Y	Y					Y
Laid up core		Y						Y				
PVC Inner sheath		Y										
Armouring		Y							Y			
Outer sheath		Y								Y	Y	Y
Finish cable (IS-1554 and 7098 – Part-1) ASTM-D-2843/ ASTM- D-2863 IEC-754 Part-I Swedish Chimney SS 4241475 for (F3 category) Flammability test IEC-332 Part –3 Cat-B	Y	Y								Y	Y	Y
Wooden drum (IS-10418) / Steel drum		Y										
Y =Test applicable												



8.6.9.2 1.1 kV PVC and XLPE CABLES		(Table 2/2)			
Item/ Components/ Sub-system	Tests/ Checks				
	Anti termite treatment on wooden drums	Constructional/ requirement as per specification	Routine and acceptance test as per relevant standard and specification	FRLS Tests	
Aluminum (IS-8130)					
PVC Compound (IS-5831)					
XLPE Compound (IS-7098 Pt-I)					
FRLS PVC Compound (IS-5831) ASTM-D-2843/ ASTM-D-2863 IEC-754 Part-I				Y	
Armour wire/strip (IS-3975)					
Insulated Core					
Laid up core					
PVC Inner sheath					
Armouring					
Outer sheath				Y	
Finish cable (IS-1554 & 7098 – Part-1) ASTM-D-2843/ ASTM- D-2863 IEC-754 Part-I Swedish Chimney SS 4241475 for (F3 category) Flammability test IEC-332 Part –3 Cat-B		Y	Y	Y	
Wooden drum (IS-10418) / Steel drum	Y				
Y =Test applicable					
Notes					
1)	(*) Not applicable for XLPE insulation				
2)	Additional acceptance tests like FRLS, thermal stability, tensile strength and elongation after ageing shall be done on one sample / lot.				
3)	Length measurement / surface finish shall be checked on one length/ size/ lot				
4)	Routine test shall be carried out on each drum length as per specifications.				



8.6.9.3 1.1 kV PVC Control cables		(Table 1/2)									
Item/ Components/ Sub-system	Tests/ Checks										
	Make, Type, Rating, Test certificate (TC)	Dimension/ surface finish	Mechanical properties	Chemical composition	Electrical properties	Spark test	Lay length/ sequence	Armour coverage, cross over, looseness, gap between two armour wire	Sequential marking/ surface finish/ cable length	Tensile strength, elongation before and after ageing of insulation and outer sheath	Thermal stability of insulation and outer sheath
Copper conductor (IS-8130)	Y	Y	Y	Y	Y						
PVC compound (IS-5831)	Y		Y		Y				Y		
FRLS PVC compound IS-5831 ASTM-D-2843/ ASTM-D-2863 IEC-754 Part-1	Y		Y						Y		
Armour wire/strip (IS-3975)	Y	Y	Y								
Insulated core		Y				Y	Y				
Laid up core		Y					Y				
PVC Inner sheath		Y									
Armouring		Y					Y				
Outer sheath		Y						Y	Y	Y	
Finished cable (IS-1554) ASTM- D-2843/ ASTM-D-2863 IEC-754 Part-1 Swedish Chimney: SEN SS 424-1475(F3 category) Flammability test IEC-332 Part-3 Cat-B	Y	Y						Y	Y	Y	Y
Wooden drum(IS:10418)/ Steel drum		Y									
Y =Test applicable											



8.6.9.3 1.1 kV PVC Control cables		(Table 2/2)			
Item/ Components/ Sub-system	Tests/ Checks				
	Anti termite treatment on wooden drums	Constructional feature as per specification	Routine and Acceptance test as per relevant standard and specification	FRLS test	
Copper conductor (IS-8130)					
PVC compound (IS-5831)					
FRLS PVC compound IS-5831 ASTM-D-2843/ ASTM-D-2863 IEC-754 Part-1				Y	
Armour wire/strip (IS-3975)					
Insulated core					
Laid up core					
PVC Inner sheath					
Armouring					
Outer sheath				Y	
Finished cable (IS-1554) ASTM-D-2843/ ASTM-D-2863 IEC-754 Part-1 Swedish Chimney: SEN SS 424-1475 (F3 category) Flammability test IEC-332 Part-3 Cat-B		Y	Y	Y	
Wooden drum(IS : 10418) / Steel drum	Y				
Y =Test applicable					
Notes					
1)	Additional acceptance tests like FRLS, thermal stability, tensile strength and elongation after ageing shall be done on one sample/ lot				
2)	Length measurement / surface finish shall be checked on one length/ size/ lot				
3)	Routine test shall be carried out on each drum length as per specifications.				

8.6.9.4 Type tests (Category-I)

The type tests on one drum out of every ten (10) drums or less for each type and size of cables shall be conducted.

- a) Annealing test (for copper) as per IS:8130
- b) Tensile test (for Aluminium) as per IS:8130



- c) Wrapping test (for Aluminum) as per IS:8130
- d) Conductor resistance test as per IS:8130
- e) Test for armour wires/ strips as per IS:3975 - The hard drawn aluminium wires armour (in case of single core cables) shall also comply with the tensile test and wrapping test as per IS:8130.
- f) Test for thickness of insulation and sheath - Requirement and methods of test for the thickness of insulation and sheaths shall be as per relevant IS. The calculated diameter over stranded core and “Calculated nominal diameter under outer sheath” shall, however, be determined by the method given in Appendix “A” of IEC-60502.
- g) Tensile strength and elongation test for insulation and sheath - The value of tensile strength and elongation at break-point shall not be less than 125kg/cm² and 150% respectively for the type ‘A’ and type ST1 PVC compounds. For XLPE insulation these tests shall be carried out in accordance with IS:7098 (Part-III). The tensile strength and elongation at a break shall not be less than 125kg/cm² and 200% respectively.
- h) Ageing test for insulation and sheath - The ageing test shall be carried out as per the procedures laid down in relevant IS, however the period of test shall be 168 hours, instead of 120 hours. The test value obtained for the tensile strength and elongation must not differ from the corresponding values obtained before ageing by more than ±25% in case of type ST2 PVC and XLPE compounds and by more than ±20% in case of type A, and type ST1 PVC compound.
- i) Loss of mass test - This test is to be carried out on the PVC insulation and sheaths as per IEC-60540. The maximum permissible loss of mass shall be 2mg/cm².
- j) Shrinkage test - This test shall be carried out on the PVC insulation and sheath. The test procedures and test values shall comply with IS:5831.
- k) Cold bend test - This test is to be carried out upto 6mm² cables size in accordance with IS:5831.
- l) Cold impact test - This test shall be carried out on the PVC insulation and sheath in accordance with IS-5831.
- m) Heat shock test for PVC insulation and sheath - This test shall be carried out as per IEC-60540 and IEC-60502.
- n) Thermal stability test for PVC insulation and sheath - This test shall be carried out in accordance with IEC-60540/60540A and shall pass the minimum requirement of 100minutes.



- o) Test for bleeding and blooming of pigments for PVC - This test shall be carried out as per IS :5831.
- p) Fire resistance test - This test shall be carried out in accordance with relevant clause of IS:5831.
- q) Measurement of insulation resistance - This test shall be carried out as per IS:5831. The volume resistivity of the PVC insulated cables shall not be less than 1×10^{14} ohm-cm at 27°C and 1×10^{11} ohm-cm at 70°C.
- r) High voltage test - This test shall be performed as per IS:1554 (Part-I).

The cable with insulation/ sheath material other than PVC shall be subject to all the tests mentioned in their respective Indian or International Standards to which they are conforming. In that case if any of the above test is not applicable, the same will not be carried out.
- s) Hot set test for insulation - This test shall be carried out as per IEC-60540 and shall pass the requirement given in IEC-60502.
- t) Partial discharge test - This test shall be carried out in accordance with IEC-60540 and IEC-60502. The test requirements are as given in IEC-60502.
- u) Bending test - The method and test requirement shall be as per IEC-60502 and on completion of this test, the sample be subject to partial discharge measurement and comply with the requirements.
- v) Tan delta measurement as a function of voltage and capacitance measurement - This test shall comply with clause 16.1.6 of IEC-60502.
- w) Tan delta measurement as a function of temperature - This test shall comply with clause 16.1.7 of IEC-60502.
- x) Heating cycle test plus partial discharge test - This test shall be carried out as per IEC-540 and IEC-502.
- y) Impulse withstand test - This test shall be carried out as per IS:7098 (Part-II). The impulse withstand voltage shall be 75 kV.
- z) High voltage test - This test shall be performed as per IS:7098 (Part –II). The normal sequence of electrical test shall be as per clause 16.1.1 of IEC-60502.



8.6.9.5 Type test (Category-I) - Additional type tests on flammability

- a) The oxygen index test shall be carried out as per ASTM-D-2863. The minimum oxygen index shall be 29.
- b) Accelerated water absorption test and dielectric retention test - This test shall be carried out in accordance with NEMA-WC-5 irrespective of thickness of insulation (applicable for the thermoplastic material only).
- c) Temperature index test for sheath - As per ASTM-D-2863 at different temperature upto 250⁰C. However, the test shall be carried out by extrapolation method beyond temperature at which the material of sheath may start deformation as per BICC Hand Book Chapter-6 on cables in fire. The number of measurements up to 200⁰C (room temperature, 50⁰C, 100⁰C, 150⁰C and 200⁰C) plotted on a graph and than extrapolated. The minimum temperature index shall be 250⁰C.
- d) Flammability of finished cables - The test shall be carried out as per requirement of Swedish Standards SS-4241475 class-F3, IEEE-383, IEC-60332 and IEC-60331 (for fire survival cables only) and cables should meet the requirement of all the above standards as mentioned in the respective category of cables.
- e) Acid gas generation during fire of sheath - The test shall be carried out as per IEC-60754-1 as well as per BS or other standard applicable for evaluation of halogen gases and the requirement of maximum halogen gases liberated shall be less than as mentioned elsewhere in the respective category of cables.
- f) Smoke generation by sheath under fire - The test shall be carried out as per ASTM-D-2843.
- g) Test for rodent and termite repulsion property of sheath - The details to be given by the manufacturer.

8.6.9.6 Site tests

The following minimum tests/ checks shall be conducted at site. Any other tests/ checks as per the manufacturer's recommendation shall also be carried out

- a) Insulation resistance test
- b) High voltage test



8.6.10 Installation of Cables, Earthing system and Lightning Protection system														
Items/ Components/ Sub-systems	Tests/ Checks													
	Make, Type, Model, Rating and TC	Dimension	Pre-treatment of sheet	Paint shade, paint thickness, adhesion	IP protection	Bought out items/ Bill of material	HV and IR	Galvanize test	Functional test as per specification	Proof load	Deflection test	Constructional feature as per specification	All Routine and acceptance tests	Item conform to relevant standard
Switch box/ Junction box/ Receptacles (IS-513, IS:5, IS:2629, IS:2633, IS:6745)	Y	Y	Y	Y	Y	Y	Y	Y	Y			Y	Y	
Cable glands (BS:6121)	Y	Y												Y
Cable lug (IS:8309)	Y	Y												Y
Lighting wire (IS:694)	Y	Y									Y			Y
Flexible conduits	Y	Y									Y			Y
Conduits (Galvanize and Epoxy) IS:9537, IS:2629, IS:2633 and IS:6745	Y	Y	Y					Y				Y		
RCC hume pipe (IS:458)	Y	Y												Y
Cable termination and Straight through joint (VDE-0278)	Y	Y			Y	Y					Y	Y		
Cable Trays, Flexible supports system and accessories IS:513, IS:2629, IS:2633 and IS:6745	Y	Y	Y			Y		Y		Y	Y	Y	Y	
Trefoil clamp	Y	Y												Y
GI flats for earthing and lightning protection (IS:2062, IS:2629, IS:6745 and IS:2633)	Y	Y	Y					Y						Y
GI wire (IS-280)	Y	Y	Y					Y						Y

Y =Test applicable



8.6.10.1 Type test (Category-II)

- i) All cable trays, supports and accessories etc supplied shall be of type tested quality.
- ii) Cable termination kit and straight through joints shall be tested as per IS:3573 for 3.3kV and 11kV class.
- iii) Fire proof cable penetration system shall be tested for the following tests:
 - Accelerated ageing test
 - Water absorption test
 - Fire rating test
 - Hose stream test
 - Vibration test followed by fire rating test

- iv) Galvanizing tests

The quality of galvanizing shall be inspected visually and shall be smooth, continuous, free from flux stains.

In addition following tests shall be conducted :

- Uniformity of coating – The coating of any article shall withstand for 1 minute dips in standard copper sulphate solution without the formation of an adherent red spot of metallic copper upon the basic metal.
- The quality of cadmium/ zinc plating on items with screw threads shall be inspected visually and shall be free from visible defects such as unplated areas, blisters and modules.
- In addition, the plating thickness shall be determined microscopically/ chemically or electronically.

- v) Welding

The quality of welding shall be visually inspected, particular attention being paid to the following points.

- The welded joints shall be continuous along its length on both sides and of uniform width and thickness. It should be free from blow holes.
- The weld metal shall be properly fused with the parent metal without undercutting.
- The outside surface of the weld shall be clean. All slag shall have been removed. All welding shall be regularly checked for cracking using magnetic particle inspection or their equivalent technique.



- vi) Physical and dimensional checks for all items
- vii) Deflection test for cable trays
- viii) Following tests shall also be carried out on each type of equipments, devices and materials/ items supplied:
 - Physical and Dimensional checks
 - Check/ measurement of thickness for Nickel chrome plating for cable glands and tinning for cable lugs.
 - Check chemical composition of brass parts for cable glands
 - Hardness check on gaskets
 - Test for uniformity of galvanization

8.6.10.2 Site tests

The following minimum tests/ checks shall be conducted at site. Any other tests/ checks as per the manufacturer's recommendation shall also be carried out

- i) Cables
 - a) Check for physical damage.
 - b) Check for insulation resistance before and after termination/ jointing.
 - c) HT cables shall be pressure tested (test voltage as per IS:7098) before commissioning.
 - d) Check of continuity of all cores of the cables.
 - e) Check for correctness of all connections as per relevant wiring diagrams. Any minor modification to the panel wiring like removing/ inserting, shorting, change in terminal connections, etc shall be carried out.
 - f) Check for correct polarity and phasing of cable connections.
 - g) Check for proper earth connections for cable glands, cable boxes, cable armour, screens etc.
 - h) Check for provision of correct cable tags, core ferrules, tightness of connections.



- ii) Cable trays/ supports and accessories
 - a) Check for proper galvanizing/ painting and identification number of the cable trays/ supports and accessories.
 - b) Check for continuity of cable trays over the entire route.
 - c) Check that all sharp corners, burrs, and waste materials have been removed from the trays supports.
 - d) Check for earth continuity and earth connection of cable trays.
- iii) Earthing and Lightning protection system
 - a) Earth continuity checks.
 - b) Earth resistance of the complete system as well as sub-system.



8.6.11 DC Storage Battery											
8.6.11.1 Lead-Acid type battery											
Item/ Components/ Sub-system	Tests/ Checks										
	Dimensions and finish	Conformance to relevant drawing	Chemical composition	Lead coating thickness (minimum 25 microns, IS:6848 and Adhesion check	Conformance to CPWD Specification for teak wood	Paint process checks, paint shade, thickness, adhesion and finish	Constructional requirements as per specification	Insulation Resistance	Marking (Routine and Acceptance test)	Checking of polarity and absence of short circuit (Routine and Acceptance test)	Test for capacities for 10 hours discharge rate along with the test for voltage during discharge (Acceptance test)
Container and Lids (IS:1146)	Y	Y									
Vent plugs	Y	Y									
Sealing compound (IS:3116)		Y	Y								
Positive and Negative plates		Y	Y								
Separators (IS:6071)	Y	Y									
Electrolyte (water/ sulphuric acid) (IS:1069/ 266)		Y	Y								
Inter-cell connectors and fasteners	Y	Y		Y							
Battery stand	Y	Y			Y	Y					
Cell insulators	Y	Y					Y				
Stack assembly	Y	Y									
Lead-Acid battery (IS:1652)	Y						Y	Y	Y	Y	
Y =Test applicable											



8.6.11.2 Ni - Cd type battery		(Table 1/2)									
Items/ Components/ Sub-system assembly	Tests/ Checks										
	Dimensions and finish	Impact strength	Conformance to relevant part drawing and Manufacturer's standards	Resistance to alkali	Chemical composition	Nickle plating thickness	Paint shade, thickness, adhesion and finish	Air pressure test after heat sealing	Marking and mass (Routine and Acceptance test)	Air pressure test (Acceptance test)	
Container and Lids (IS:1146)	Y	Y	Y	Y							
Vent Plugs	Y		Y	Y							
Perforated steel strips	Y		Y	Y		Y					
Active material for positive and negative Plates			Y		Y						
Separators	Y		Y	Y							
Electrolyte			Y		Y						
Inter-cell connectors and fasteners	Y		Y	Y		Y					
Battery stand	Y			Y			Y				
Cell Insulators	Y		Y	Y							
Stack assembly	Y		Y					Y	Y		
Ni-Cd Battery (IS:10918)	Y								Y	Y	
Y =Test applicable											

8.6.11.2 Ni- Cd type battery		(Table 2/2)			
Items/ Components/ Sub-system assembly	Tests/ Checks				
	Retention of charge test (Acceptance test)	AH test (Acceptance test)	Insulation Resistance (Acceptance test)	Polarity and absence of short circuit (Routine and Acceptance test)	
Container and Lids (IS:1146)					
Vent Plugs					
Perforated steel strips					
Active material for positive and negative Plates					
Separators					
Electrolyte					
Inter-cell connectors and fasteners					
Battery stand					
Cell Insulators					
Stack assembly		Y		Y	
Ni-Cd Battery (IS:10918)	Y	Y	Y	Y	
Y =Test applicable					

8.6.11.3 Type test (Category-II)

All batteries supplied shall be of type tested quality.

8.6.11.3.1 Lead -Acid Plante battery

- i) Type test reports for the following shall be submitted for purchaser's approval :
 - a) Container (Rubber and Plastic containers)
 - High voltage test
 - Drop ball test
 - Plastic Yield test



- Acid resistance test
 - Hydraulic thrust endurance test.
- b) Cells and batteries
- Tests for capacities for 10 hr and 30 minutes discharge rates and test for voltage during discharge.
 - Ampere hours and watt-hour efficiency test.
 - Tests for retention of charge.
 - Endurance tests.
- ii) Acceptance Tests - All acceptance tests as listed below shall be carried out on sample cell selected at random by the purchaser before dispatch and at site after completion of installation.
- Verification of markings.
 - Verification of dimensions.
 - Test for capacities for 10 hrs discharge rate along with the test for voltage during discharge.

If a battery fails to meet the guaranteed requirements, the purchaser shall have the option of asking to replace the same.

8.6.11.3.2 Nickel-Cadmium battery

- i) Type test reports for the following shall be submitted for purchaser's approval :
- a) Life cycle test
 - b) Tests for capacities for 5 hr and ½ hr. discharge rates and test for voltage during discharge
 - c) Ampere hours and watt-hour efficiency test
 - d) Tests for retention of charge
 - e) Endurance tests
 - f) Discharge performance at low temperature
- ii) Acceptance Tests - All acceptance tests as listed below shall be carried out on sample cell selected at random by the purchaser before dispatch and at site after completion of installation.
- a) Physical examination
 - b) Dimensions, mass and layout
 - c) Marking
 - d) Polarity and absence of short circuit.
 - e) Air pressure test
 - f) Ampere - hour capacity
 - g) Retention of charge
 - h) Insulation resistance



If a battery fails to meet the guaranteed requirements, the purchaser shall have the option of asking to replace the same.

8.6.11.4 Site tests

The following minimum tests/ checks shall be conducted at site. Any other tests/ checks as per the manufacturer's recommendation shall also be carried out

- Physical examination
- Dimensions, mass and layout
- Marking
- Polarity
- Insulation resistance



8.6.12 Battery Charger													
Item/ Components/ Sub-system	Tests/ Checks												
	Make, Model, Type, Rating and Finish	Chemical and Mechanical tests	Sheet steel pretreatment and painting process checks	Conform to relevant standard	Dimensional check and paint shade, thickness, adhesion and finish checks	Complete physical examination for constructional features of battery charger as per specification	Temperature rise test	Dynamic response test	Ripple content test, load limiter and Annunciator and AVR operation test	Operational and functional checks	HV and IR test	Burn-in test at 50°C for 48 hrs	Degree of protection test .
Rectifier transformer (IS:2026)	Y			Y			Y				Y		
Electronic components including potentiometer (vernier type)	Y			Y									
PCB and electronic cards	Y			Y									
19"standard racks for electronic card	Y					Y							
Control and selector switches (IS:6875)	Y			Y						Y			
Indicating meters (IS:1248)	Y			Y						Y			
Indicating lamps (IS:13947)	Y			Y						Y			
Air break switches/ Fuses (IS:13947/ 13703)	Y			Y						Y			
Control terminal blocks (IS:13947)	Y			Y									
Control transformer (IS:12021)	Y			Y						Y			
Push buttons (IS:4794)	Y			Y						Y			
MCB (IS:8828)	Y			Y						Y			
PVC insulated copper control wires (IS:694)	Y			Y									
Sheet steel (IS:513)	Y	Y	Y	Y									
Synthetic rubber gaskets	Y	Y		Y									
Annunciator	Y									Y		Y	
Battery charger	Y				Y	Y	Y	Y	Y		Y	Y	Y
Y =Test applicable													



8.6.12.1 Type test (Category-II)

All battery chargers supplied shall be of type tested quality.

Type test reports for the following shall be submitted for purchaser's approval :

- i) Complete physical examination
- ii) Temperature rise test at full load.
- iii) Temperature rise test of rectifier assembly at 200% of full load.
- iv) Insulation resistance test.
- v) High voltage (power frequency) test on power and control circuits except low voltage electronic circuits.
- vi) Ripple content test at no load, half load and full load
- vii) Automatic voltage regulator operation test at specified AC supply variations at no load, half load and full load
- viii) Load limiter operation test
- ix) Efficiency and power factor measurement.
- x) Input and output surge withstand capability test. Surge voltage as per ANSI-C37.90a shall be applied for period not less than 2 second at the following points of the charger operating at 50⁰C at full load :

- Across each AC input phase
- Across AC input line to ground.
- Across DC output terminals.
- Across each DC output terminal to ground

The charger shall not exhibit any component damage and there shall be no change in performance as per tests at (vii) and (viii).

- xi) Environmental tests - Steady state performance tests (vii) and (viii) shall be carried out before and after each of the following tests.
 - a) Soak Test - The electronic modules shall be subjected to continuous operation for a minimum period of 72 hours. During last 48 hours, the ambient temperature shall be maintained at 50⁰C. The 48 hour test period shall be divided into four equal 12 hour segments. The input voltage during each 12 hours shall be nominal voltage for 11 hours followed by 110% of nominal voltage for 30 minutes, followed by 90% of nominal voltage for 30 minutes.
 - b) Degree of protection test.

8.6.12.2 Site tests

The following minimum tests/ checks shall be conducted at site. Any other tests/ checks as per the manufacturer's recommendation shall also be carried out

- i) Complete physical examination
- ii) Checking of proper operation of annunciation system
- iii) Temperature rise test at full load



- iv) Insulation resistance test
- v) Automatic voltage regulator operation
- vi) Load limiter operation.
- vii) Dynamic response test - overshoot/ undershoot in output voltage of the charger as a result of sudden change in load from 100% to 20% and 20% to 100% shall be measured with the batteries connected and disconnected. Output voltage of the charger connected with battery shall be within 94% to 106% of the voltage setting in above conditions and shall return to, and remain, within the limits specified as mentioned elsewhere, in less than 2seconds (as applicable).



8.6.13 Protection and relay panel for generator, generator transformer and UATs													
Items/ Components/ Sub-systems	Tests/ Checks												
	Make, Type, Model, Rating and TC	Electrical Properties			Dimensions and Finish	Functional and operational features	Item to conform to relevant Standards	Pretreatment as per IS 6005	Paint shade, thickness, adhesion and finish	Functional checks	HV and IR test	Degree of Protection - Routine test	All Routine tests as per relevant standards
Protective relays (IS:3231/8686)	Y				Y	Y	Y			Y			Y
Auxiliary relays (IS:3231/8686)	Y				Y	Y	Y			Y			Y
Control and selector switches (IS:6875)	Y				Y	Y	Y			Y			
Indicating meters (IS:1248)	Y				Y	Y	Y			Y			Y
Indicating lamps (IS:13947)	Y				Y	Y	Y			Y			
Push buttons (IS: 4794)	Y				Y	Y	Y			Y			
Control transformer (IS:12021)	Y				Y	Y	Y						Y
LT fuses (IS:13703)	Y				Y	Y	Y						
Energy meters (IS:722)	Y				Y	Y	Y						Y
Transducers (IEC:60688)	Y				Y	Y	Y						Y
Diodes	Y	Y				Y	Y			Y			
Terminal Blocks	Y	Y				Y	Y						
Synthetic Rubber Gasket (IS:11149/3400)	Y	Y			Y		Y						
Complete Panel (IS:3427)	Y				Y	Y	Y	Y	Y	Y	Y	Y	Y
Test realy kit	Y									Y			Y
Y =Test applicable													



8.6.13.1 Type test (Category-II)

The Protection and Relay panels shall be of type tested quality.

- i) For various bought out items like CT, VT, relays etc for which identification can be physically verified and test certificate from manufacturer can be co-related, following shall be indicated in the QP.
 - Review of manufacturer's TC as per relevant standard and compliance to requirements of this specification
 - Physical check and functional/ operational check to ensure that item is fit for assembly on the switch board cubicle.
- ii) For all other items where identification has not been envisaged by manufacturers, a certificate of conformance to be obtained from manufacturer, and component identification shall be tagged as per approved drawing/ schematic. Either of the following or both shall be adopted .
 - Random sample to be tested either in-house or at an independent laboratory for all tests envisaged in relevant standard.
 - Physical check and functional/ operation check to ensure the item is fit for assembly on the panel.

8.6.13.2 Site tests

The following minimum tests/ checks shall be conducted at site. Any other tests/ checks as per the manufacturer's recommendation shall also be carried out

- a) Cubicle Wiring
 - i) It should be made sure that the wiring is as per relevant drawings. All interconnections between panels shall similarly be checked
 - ii) Insulation resistance of all the wires with respect to earth
 - iii) Functional checking of all control circuit e.g. closing, tripping interlock, supervision and alarm circuit including proper functioning of component/ equipment
 - iv) Check terminations and connections
 - v) Wire ducting
 - vi) Gap sealing and cable bunching
- b) Relays
 - i) Check internal wiring
 - ii) Insulation resistance between all terminals and body
 - iii) Insulation resistance between AC and DC terminals
 - iv) Check operating characteristics by secondary injection
 - v) Check minimum pick up voltage of DC coils



- vi) Check operation of electrical/ mechanical targets
 - vii) Check CT connections with particular reference to their polarities for differential type relays
 - viii) Relay settings
- c) Meters
- i) Insulation resistance of all insulated portions
 - ii) Check CT and VT connections with particular reference to their polarities for power type meter
- d) General
- i) Wiring check in conformity with schematics.
 - ii) Insulation check.
 - iii) Primary injection test.
 - iv) Secondary injection test.
 - v) On load test.
 - vi) DC sequential test.



8.6.14 Emergency Diesel Generating Set										
8.6.14.1 Diesel Engine										
Items/ Components	Tests/ Checks									
	Material test	DP or MPI	UT (on forging and piston bonding)	Balancing	Hydraulic, water fill test	Assembly, Fit up	Dimension	Functional/ Operation test	Performance test as per BS-5514/ or equivalent IS/ ISO Standard including Governing test for 3 hours at full load and one hour at 10%	Fuel consumption, rated power measurement, rated speed
Crank shaft	Y	Y	Y	Y						
Cylinder blocks/ heads	Y				Y					
Liner radiator	Y				Y					
Rotating, moving parts other than crank shaft	Y	Y								
Piston	Y	Y	Y							
Diesel Engine						Y	Y	Y	Y	Y
Y =Test applicable										



8.6.14.2 Alternator		(Table 1/2)												
Items/ Components	Tests/ Checks													
	Visual	Dimension	Make, Type, Rating, TC, General physical inspection	Mechanical, Chemical properties	NDT, DP or MPI, UT	Metallography	Electrical characteristics	Welding/ Brazing (WPS/ PQR)	Heat treatment	Magnetic characteristics.	Hydraulic, Leak, Pressure test	Thermal characteristics	Run out	Dynamic balancing
Plates for stator frame, end shield, spider etc.	Y	Y	Y	Y					Y					
Shaft	Y	Y	Y	Y	Y	Y			Y					
Magnetic material	Y	Y	Y	Y	Y		Y			Y		Y		
Rotor copper/ aluminium	Y	Y	Y	Y		Y	Y		Y					
Stator copper	Y	Y	Y	Y			Y		Y			Y		
SC ring	Y	Y	Y	Y	Y	Y	Y	Y	Y					
Insulating material	Y		Y	Y			Y					Y		
Tubes for cooler	Y	Y	Y	Y	Y				Y		Y			
Sleeve bearing	Y	Y	Y	Y	Y				Y		Y			
Stator, Rotor, Exciter coils	Y	Y	Y				Y	Y						
Castings, stator frame, terminal box and bearing housing etc.	Y	Y	Y	Y	Y			Y						
Fabrication and machining of stator, rotor, terminal box	Y	Y			Y				Y					
Wound stator	Y	Y					Y	Y						
Wound exciter	Y	Y					Y	Y						
Rotor complete	Y	Y					Y						Y	Y
Exciter, Stator, Rotor, Terminal box	Y	Y					Y							
Accessories, RTD, BTD, CT, AVR. Brushes, Diodes, Space heater, antifriction, bearing, cable glands, lugs, gaskets etc.	Y	Y	Y											
Alternator (IS:4722)	Y	Y	Y											

Y =Test applicable Y1 = for HT Machines only



8.6.14.2 Alternator	(Table 2/2)			
	Tests/ Checks			
Items/ Components	All tests as per IS:4722	Vibration	Overspeed	Tan delta, shaft voltage and polarization index
Plates for stator frame, end shield, spider etc.				
Shaft				
Magnetic Material				
Rotor copper/ aluminium				
Stator copper				
SC Ring				
Insulating material				
Tubes for cooler				
Sleeve bearing				
Stator/ Rotor, Exciter coils				
Castings, stator frame, terminal box and bearing housing etc.				
Fabrication and machining of stator, rotor, terminal box				
Wound stator				
Wound exciter				
Rotor complete				
Exciter, Stator, Rotor, Terminal box				
Accessories, RTD, BTD, CT, AVR. Brushes, Diodes, Space heater, antifriction, bearing, cable glands, lugs, gaskets etc.				
Alternator (IS:4722)	Y	Y	Y	Y1
Y =Test applicable Y1 = for HT Machines only				

8.6.14.3 Final assembly										
Items/ Components	Tests/ Checks									
	Material test	Dimension	WPS, PQR, Welding	NDT, DP or MPI, UT	Check completeness	Hydraulic, Leak, Pressure test	Functional test	All Routine test as per Specification /IS	No load test for one hour of the DG set assembly	Clearances and alignment
Base frame	Y	Y	Y	Y	Y					
Fuel tank	Y	Y	Y	Y	Y	Y				
Battery (IS:1691)								Y		
Battery charger								Y		
Control panel								Y		
Assembled DG set		Y			Y		Y		Y	Y

Y =Test applicable

8.6.14.4 Type test (Category-II)

All DG sets and accessories supplied shall be of type tested quality.

Type test reports for the following shall be submitted for purchaser's approval :

- a) Measurement of resistance and air gap
- b) Phase sequence test
- c) Regulation test
- d) Measurement of open circuit and short circuit characteristics
- e) Efficiency test
- f) Temperature rise test
- g) Momentary overload test
- h) Overspeed test
- i) High Voltage test
- j) Insulation resistance test (both before and after high voltage test)
- k) Noise level as per IS:12065
- l) Vibration as per IS:12075



- m) Determination of deviation of voltage waveform from sinusoidal
- n) Degree of protection test on control panel for IP-52

8.6.14.5 Site Tests

The following minimum tests/ checks shall be conducted at site. Any other tests/ checks as per the manufacturer's recommendation shall also be carried out

- a) Visual Test
- b) Electrical Tests
 - i) Calibration of instruments, relays etc.
 - ii) Primary and secondary injections tests of protective devices.
 - iii) Function, interlock test of control panel
 - iv) Insulation resistance measurement of power and control circuits.
- c) Mechanical Tests
 - i) Trial run of engine
 - ii) Governor testing
 - iii) Overspeed trip test
 - iv) Load pick up and load rejection tests
 - v) Load test and temperature rise measurement of engine and alternator



8.6.15 Electro Static Precipitator (ESP) – Electrical				
8.6.15.1 General				
Items/ Components	Tests/ Checks			Remarks
	Visual	Make, Type, Rating etc.	Final Inspection as per IS/ IEC /BS	
TR Set	Y	Y		Refer table for TR
ESP insulator (IEC 168/ 273, IS 2544)	Y	Y	Y	ESP insulators shall be additionally subjected to high temperature test on sample basis as per mutually agreed upon procedure.
Electrostatic Precipitation Management System	Y	Y		Refer table for annunciation, control, PLC Panel
Microprocessor based rapper controller	Y	Y		Refer table for annunciation, control, PLC Panel
Disconnecting switch (IS 13947)	Y	Y	Y	
Heaters (IS 4159/ BS 6351)	Y	Y	Y	



8.6.15.2 Transformer Rectifier (TR) Set												(Table 1/2)	
Items/ Components	Tests/ Checks												
	Visual	Dimensional and physical	Make, Type, Rating	Mechanical, chemical Properties	Electrical	Electronics	Welding	NDT	Pretreatment of tank	Painting	All tests as per IS2026	All tests as per IEC-146	
Thyristor	Y	Y	Y			Y						Y	
Contactor	Y	Y	Y		Y								
Switch Fuse Unit	Y	Y	Y		Y								
HRC Fuse	Y	Y	Y		Y								
Current Transformer	Y	Y	Y		Y								
Overvoltage Protector	Y	Y	Y		Y								
Measuring Instruments	Y	Y	Y		Y								
Control Transformer	Y	Y	Y		Y								
Bushings	Y	Y	Y		Y								
Dial Thermometer	Y	Y	Y		Y								
Resistor wire wound	Y	Y	Y		Y								
Sudden Pressure Relay	Y	Y	Y		Y								
PVC insulated copper wire (ISI Marked)	Y	Y	Y		Y								
Terminal Block	Y	Y	Y		Y								
Gasket	Y	Y	Y	Y									
Electrolytic copper	Y	Y	Y	Y									
Capacitor, Resistor	Y	Y	Y	Y	Y	Y							
PCB	Y	Y	Y		Y								
Insulated conductor	Y	Y	Y	Y	Y								
Laminations	Y	Y	Y	Y	Y								
Press board, paper	Y	Y	Y	Y	Y								
Insulating oil (Silicon)	Y		Y	Y	Y								



8.6.15.2 Transformer Rectifier (TR) Set		(Table 2/2)											
Items/ Components	Tests/ Checks												
	Visual	Dimensional and physical	Make, Type, Rating	Mechanical, Chemical Properties	Electrical	Electronics	Welding	NDT	Pretreatment of tank	Painting	All tests as per IS2026	All tests as per IEC-146	
Radiator	Y	Y	Y	Y				Y					
Transformer Tank	Y	Y	Y	Y			Y	Y					
Panel Fabrication	Y	Y	Y	Y			Y		Y	Y			
Electronic Cards	Y	Y	Y		Y	Y							
Linear Reactor, Choke	Y	Y	Y	Y	Y								
Transformer Assembly	Y	Y		Y	Y								
Control Panel	Y	Y	Y	Y	Y	Y				Y			
HV, TR Set	Y	Y	Y		Y	Y				Y	Y		
ESP Controller (Separate QP)	Y	Y	Y		Y	Y	Y		Y		Y		



8.6.15.3 Annunciation, Control, PLC Panel													
Items/ Components	Tests/ Checks												
	Visual	GA, BOM, Lay out of components	Dimensions, General physical inspection	Paint shade, thickness, adhesion	Component Rating, Make, Type	Wiring	IR and HV	Review of TC for instruments	Accessibility of devices	Illumination	Functional check for control element ,	Test as per IEC:1131 *	Routine and acceptance tests as per IS 8623
Annunciation, Control, PLC Panel	Y	Y	Y	Y	Y	Y	Y	Y	Y	Y	Y	Y	Y
Notes													
1)	Detailed procedure of Burn-in and Elevated temperature test shall be as per Quality Assurance Programme												
2)	(*) Applicable for PLC												



STANDARD TECHNICAL SPECIFICATION FOR MAIN PLANT PACKAGE

SECTION- 9

(MANDATORY SPARES)

9.0 GENERAL

- i) Quantity of mandatory spares specified in this section are on unit basis i.e. double the quantities are to be supplied for two units except where it is specifically mentioned that the quantities are for both the units.
- ii) One set means the quantity used in one unit unless specifically indicated otherwise.
- iii) Wherever, quantities are specified in percentage, the minimum quantity to be supplied shall be rounded off to the next integer unless mentioned otherwise.



9.1 STEAM GENERATOR AND AUXILIARIES (FOR EACH UNIT)

9.1.1 Pressure Parts

A) Economiser

- i) Straight tube 200m total for each size, type, thickness and material
- ii) Coil end bends 50 nos. of each size, type, thickness, radius and material.

B) Water wall

- i) Straight tube and spiral tube 200m total quantity for each type, thickness, size and material.
- ii) Bends for burner elevation 20 nos. for each size, type, thickness, radius and material
- iii) Screen water wall tube (if applicable) 200m including all types, size and material

C) Low temperature super heater (LTSH)

- i) Straight tube of 8-10 m length 250m total length for each size, thickness, types and material
- ii) Bends 20 nos. of each size, type, thickness, radius and material.

D) Intermediate temperature superheater (ITSH)/ platen superheater

- i) Straight tube 100 m total length of each size, thickness, type and material
- ii) Bends 20 nos. of each size, thickness, radius, type and material
- iii) Male and female couplings spacers 5 sets

E) High temperature superheater (HTSH)/ final superheater

- i) Straight tube 100m total length of each size, thickness, type and material



ii) Bends 20 nos. of each size, thickness, type, radius and material

iii) Male and female couplings spacers 5 sets

F) Reheater

i) Straight tube 200m total length of each size, thickness, type and material

ii) Bends 20 nos. of each size, thickness, type, radius and material

iii) Male and female couplings spacer 5 sets

9.1.2 Headers

A) Water wall headers

i) Handhole plate 2 nos.

ii) Yoke plate with fasteners 2 sets

B) Superheater headers

i) Hand hole plate assembly 2 nos. of each type

ii) Radiographic plug 6 nos. (wherever applicable)

C) Reheater headers

i) Hand hole plate assembly 2 nos. of each type

ii) Radiographic plug 6 nos. (wherever applicable)

9.1.3 Superheater and Reheater Attenuation System

Desuperheater liners 2 sets of each type

9.1.4 Steam Drum

i) Manhole gasket for drum 12 nos.

ii) Local water level gauge glass assembly 1 set

iii) Spares for direct water level gauge 1 set
(Repair kit for above such as port assembly, glass strip lamps spring cones, gaskets etc.)



- iv) Spares for remote level indicator
(Repair kit such as seal ring bull
deflector plate, gasket, diaphragm etc.) 1 set
- v) Spare isolating valve assembly for
above gauge glass 1 set

9.1.5 Boiler Water Circulation Pumps

- i) Complete pump and motor assembly 1 no.
- ii) Motor stator winding 1 no.
- iii) Journal bearing 2 sets *
- iv) Thrust bearing 2 sets *
- v) Casing wear rings 2 sets *
- vi) Impeller wear rings 3 sets *
- vii) Set of gaskets 5 sets * (All gaskets including
heat exchanger)
- viii) Set of 'O' rings 5 sets *
- ix) Gland packings 5 sets *
- x) Motor heat exchanger 1 set *
- xi) Thermocouples 1 set *
- xii) Temperature switches 1 set *
- xiii) Pressure switches 1 set *
- xiv) Flow switches 1 set *

* One set means one complete replacement for one equipment.

9.1.6 Fans

A) ID Fans

- i) **Radial type (as applicable)**
 - a) Fan rotating element (including
impeller and shaft) 1 set*
 - b) Impeller liners 2 sets*
 - c) Casing liners 2 set*
 - d) Motor bearings 2 sets*
 - e) Fan bearings 2 sets*



- f) Seals, 'O' rings oil rings for all the fan bearings 6 sets*
- g) Lube oil system
- Pump assembly 1 no.
 - Pressure regulator 2 nos.
 - Filters 8 nos.
 - Coupling between oil pump and motor 2 nos.
 - Coolers 1 set*
- h) Inlet guide vanes (IGV) 1 set*
- ii) **Axial type (as applicable)**
- a) Fan rotor complete (including impeller and shaft) 1 no.
- b) Fan bearings 1 set*
- c) Motor bearings 1 set*
- d) Fan blades 2 sets*
- e) Spares for blade bearing assembly
- Bearings 4 sets*
 - 'O' rings 4 sets*
 - Bushes 4 sets*
 - Metallic rings 4 sets*
 - Intermediate piece (if applicable) 3 sets*
- f) Lube oil system
- Pump assembly 1 no.
 - Pressure regulator 2 nos.
 - Filters 8 nos.
 - Coupling between oil pump and motor 2 nos.
 - Coolers 1 set*
- g) Couplings between fan and motor 2 nos.



h)	Hydraulic servomotor	2 nos.
B) FD fans		
i)	Fan rotor complete (including impeller and shaft)	1 no.
iii)	Fan bearings	1 set*
iv)	Motor bearings	1 set*
v)	Fan blades	2 sets*
vi)	<u>Spares for blade bearing assembly</u>	
a)	Bearings	2 sets*
b)	'O' rings	2 sets*
c)	Bushes	2 sets*
d)	Metallic rings	2 sets*
e)	Intermediate piece (if applicable)	3 sets*
vii)	<u>Lube oil system</u>	
a)	Pump assembly	1 no.
b)	Pressure regulator	3 nos.
c)	Filters	8 nos.
d)	Coupling between oil pump	2 nos.
e)	and motor	
f)	Coolers	1 set*
viii)	Couplings between fan and motor	2 nos.
ix)	Hydraulic servomotor	2 nos.
C) PA Fan		
i)	Fan rotor complete (including impeller and shaft)	1 no.
ii)	Fan bearings	1 set*
iii)	Motor bearings	1 set*
iv)	Coupling between fan and motor	1 no.



Section- 9 (Mandatory Spares)

- | | | |
|-------|---|---------|
| v) | Fan blades | 2 set* |
| vi) | <u>Spares for blades bearing assembly</u> | |
| a) | Bushes | 2 sets* |
| b) | Bearings | 2 sets* |
| c) | 'O' rings | 2 sets* |
| d) | Metallic rings | 2 sets* |
| e) | Intermediate piece (if applicable) | 2 sets* |
| vii) | <u>Lube oil system</u> | |
| a) | Pump assembly | 1 no. |
| b) | Pressure regulator | 3 nos. |
| c) | Filters | 8 nos. |
| d) | Pump and motor coupling | 3 nos. |
| e) | Coolers | 1 set* |
| viii) | Hydraulic servomotor | 2 nos. |

Note : * one set means one complete replacement for one fan.



9.1.7 Coal Pulverizers

- i) Grinding elements
 - a) Rollers/ tyres 4 sets **
 - b) Bull ring segments/ bowl / rings 4 sets**

Note : **One set of grinding element at (a) and (b) above is defined as under:

1 set = (Grinding elements needed for complete replacement of one mill) x
(8000 x N), rounded off to nearest higher whole number.
GWL

Where:

GWL = Guaranteed wear life of grinding element (a) and (b) as offered by the bidder.

N = Number of mills installed for one steam generator unit.

- ii) Gear box internals (except bearings and seals) 6 sets*
- iii) Complete gearbox 2 sets*
- iv) Bearings 3 sets*
- v) Seals and rings 4 sets*
- vi) Mill motor bearings 4 sets*
- vii) Liners with brackets and fasteners 4 sets*
- viii) Discharge valve assembly 3 sets*
- ix) Multiport outlet and liners 4 sets*
- x) Mill main shaft/yoke 1 no.
- xi) Journal and spring 10 nos.
- xii) Hydraulic loading cylinder 3 nos.
- xiii) Filter cartridges 10 nos.
- xiv) Actuators (complete) 1 no. of each type
- xv) Actuator spare kits 1 set of each type*
- xvi) Mill bottom 2 nos.



xvii) Bowl hub assembly/ ring seat	1 no.
xviii) Lower skirt	1 no.
xix) <u>Lube oil system</u>	
a) Pump assembly	3 nos.
b) Pressure regulator	3 nos. for each type
c) Filters	12 nos.
d) Pump and motor coupling	4 nos.
e) Coolers	2 sets*

* One set means one complete replacement of one mill

9.1.8 Feeders

i) Belt	10 sets*
ii) Belt drive motor	2 nos.
iii) Belt drive reducer	2 nos.
iv) Clean out conveyor motor	2 nos.
v) Clean out conveyor reducer	2 nos.
vi) Counter assembly (complete)	1 no.
vii) Head pulley assembly (complete)	2 nos.
viii) <u>Weight sensing system</u>	
a) Weighting rolls	2 nos.
b) Weighting spare roller assembly	2 nos.
c) Drag link assembly	2 nos.
ix) Tension rolls	2 nos.
x) Worm	2 nos.
xi) Worm wheel	2 nos.
xii) Feeder gate	2 nos.
xiii) Actuators	1 no. of each type

* One set means one complete replacement of one feeder



9.1.9 Coal Burners and Coal Pipe Bends

i)	Coal compartment assembly	1 set
ii)	Inter air compartments	1 set
iii)	Oil compartments/ oil nozzle tips	1 set
iv)	End air compartment	1 set
v)	Coal nozzle castings	1 set
vi)	Adjustable coal nozzle tips	1 set
vii)	Coal pipe bends with liners size,	100% of population for each type, size, thickness and radius
viii)	Victualic couplings	25 nos. of each size
ix)	Victualic coupling gasket	60 nos. of each size

9.1.10 Seal Air Fan

i)	Impeller with shaft	1 no.
ii)	Bearings and seals	2 sets*
iii)	Motor bearings	2 sets*
iv)	Motor	1 no.

* One set means complete replacement of one fan

9.1.11 Air Preheaters (APH)

A) Secondary air preheaters

i)	Support bearing	2 nos.
ii)	Guide bearing	2 nos.
iii)	<u>Lubricating system of support and guide bearing</u>	
a)	Pump assembly	1 no.
b)	Pressure regulator	1 no.
c)	Filters	6 nos.



Section- 9 (Mandatory Spares)

d)	Pump motor coupling	3 nos.
e)	Coolers	1 set
iv)	Radial seals	3 sets*
v)	Axial seals	3 sets*
vi)	Circumferential or bypass seals	2 sets*
vii)	Rotor post seals	3 sets*
viii)	Air motor	2 nos.
ix)	Bearings and seals for air motor	2 sets*
x)	<u>Speed reducer</u>	
a)	Complete speed reducer	1 set*
b)	Speed reducer gears, pinions and shaft	1 set*
c)	Speed reducer bearings	1 set*
d)	Speed reducer seals and gaskets	2 sets*
e)	Speed reducer clutch assembly	1 no.
xi)	Fluid coupling	3 nos.
xii)	Other couplings with inserts and fasteners	2 nos.
xiii)	Solenoid valves	2 nos.
xiv)	Spare kit for rotor stoppage alarm	1 set*
xv)	Spare kit for fire sensing device	1 set*
xvi)	<u>Spares for cleaning device</u>	
a)	Worm and worm wheel for gear reducer	1 set*
b)	Coupling	1 set*
c)	Bearing and seals for speed reducer	1 set*
d)	Bearing for cleaning device	2 sets*
xvii)	Bushings for worm gear reducer	1 set*



- xviii) Actuators 1 no.
- xix) Cold, intermediate and hot end baskets 2 sets for each type and size*

B) Primary air pre heaters (if applicable)

- i) Support bearing 1 no.
- ii) Guide bearing 2 nos.
- iii) Lubricating system of support and guide bearing
- a) Pump assembly 1 no.
- b) Pressure regulator 1 no.
- c) Filters 6 nos.
- d) Pump motor coupling 3 nos.
- e) Coolers 1 set
- iv) Radial seals 3 sets*
- v) Axial seals 3 sets*
- vi) Circumferential or bypass seals 2 sets*
- vii) Rotor post seals 3 sets*
- viii) Air motor 2 nos.
- ix) Bearings and seals for air motor 2 sets*
- x) Speed reducer
- a) Complete speed reducer 1 set*
- b) Speed reducer gears, pinions and shaft 1 set*
- c) Speed reducer bearings 1 set*
- d) Speed reducer seals and gaskets 2 sets*
- e) Speed reducer clutch assembly 1 no.
- xi) Fluid coupling 3 nos.
- xii) Other couplings with inserts and fasteners 2 nos.



xiii)	Solenoid valves	2 nos.
xiv)	Spare kit for rotor stoppage alarm	1 set *
xv)	Spare kit for fire sensing device	1 set *
xvi)	<u>Spares for cleaning device</u>	
a)	Worm and worm wheel for gear reducer	1 set *
b)	Coupling	1 set *
c)	Bearing and seals for speed reducer	1 set *
d)	Bearing for cleaning device	2 sets *
xvii)	Bushings for worm gear reducer	1 set *
xviii)	Actuators	1 no.
xix)	Cold, intermediate and hot end baskets	2 sets for each type and size*

* One set means one complete replacement for one APH.

9.1.12 Fuel Oil System

A) Heavy fuel oil system

i)	Fuel oil guns	1set
ii)	Oil gun nozzle (with back plate, mixing plate and cap nut)	2 sets
iii)	Oil gun flexible hoses (including for guide pipe, air line)	2 sets
iv)	<u>Spares for heavy oil pump</u>	
a)	Complete cartridge assembly	2 sets*
b)	Mechanical seals	3 sets*
c)	Bearings including that of motor	2 sets*
d)	Set of 'O' ring and seals	4 sets*
e)	Set of all types of bushes and sleeves	4 sets*
f)	Set of gaskets	4 sets*



- | | | |
|-----------|--|------------------------------------|
| v) | Heavy oil pump relief valve complete with accessories | 1 no. |
| vi) | <u>Spares for oil pump relief valve</u> | |
| a) | Valve spindle and disc | 1 no. |
| b) | Set of gasket | 2 sets |
| c) | Sealing ring | 2 sets |
| d) | Springs | 1 set |
| vii) | <u>Burner isolation valves</u> | |
| a) | Isolation valves | 12 nos. or 10% whichever is higher |
| b) | Gaskets for above valves | 2 sets |
| c) | Gland packings for above valves | 2 sets |
| viii) | Heavy oil pressure control valve | 1 no. |
| ix) | Heavy oil main trip valve complete | 1 no |
| x) | Atomising steam pressure reducing valve | 1 no. |
| xi) | Heavy oil temperature control valve | 1 no. |
| xii) | Actuators of above valves | 1 no. of each type and rating |
| B) | Light oil system | |
| i) | Light oil gun | 25% of population |
| ii) | Oil gun nozzle (with back plate, mixing plate and cap nut) | 2 sets |
| iii) | Spares for light oil pump | |
| a) | Complete cartridge assembly | 2 sets* |
| b) | Mech. seals | 4 sets* |
| c) | Bearings including that of motor | 2 sets* |
| d) | Set of 'O' rings and seals | 4 sets* |
| e) | Set of all types of bushes and sleeves | 4 sets* |
| f) | Set of gaskets | 4 sets* |
| iv) | Light oil pump relief valve complete with accessories | 1 no. |



- v) Spares for oil pump relief valve
 - a) Valve spindle and disc 1 no.
 - b) Set of gasket 2 sets
 - c) Sealing ring 2 sets
 - d) Springs 1 set
- vi) Burner isolation valves
 - a) Isolation valves 12 nos. or 10%
whichever is higher
 - b) Gaskets for above valves 2 sets
 - c) Gland packings for above valves 2 sets
- vii) Light oil pressure control valve 1 no.
- viii) Light oil main trip valve complete 1 no.
- ix) Atomising steam pressure reducing valve 1 no.

* One set means one complete replacement of one pump

9.1.13 HEA Ignitors

- i) HEA retractor 2 sets *
- ii) HEA spark rod 2 sets *
- iii) HEA spark tip 2 sets *
- iv) HEA exciter 4 nos. of each type and rating
- v) Solenoid valves 4 nos. of each type and rating
- vi) Limit switch 4 nos. of each type and rating
- vii) Solenoid valve coil 8 nos. of each type and rating
- viii) HEA spark gap 8 nos.
- ix) HEA transformer 8 nos.
- x) HEA rectifier 8 nos.
- xi) HEA inductor 8 nos.



- | | |
|-----------------|--------------------------------|
| xii) Resistor | 8 nos. of each type and rating |
| xiii) Capacitor | 4 nos. of each type and rating |

* One set means one complete replacement of one HEA ignitor.

9.1.14 Soot Blowers

- | | |
|---|--------------------|
| i) Complete assembly of water wall deslagger | 4 nos. |
| ii) Motor for water wall deslaggers | |
| a) For rotary motion | 3 nos. |
| b) For traverse motion | 3 nos. |
| iii) Complete valve assembly for water wall deslagger. | 6 nos. |
| iv) Motor for long travel retractable soot blower | |
| a) For rotary motion | 2 nos. |
| b) For traverse motion | 2 nos. |
| v) Complete valve assembly for long retractable soot blower. | 2 nos. |
| vi) Complete motor for air preheater soot blower | 1 no. of each type |
| vii) Reduction gear box and motor for air preheater soot blower oscillation | 1 no of each type |
| viii) Complete valve assembly for air preheater soot blower | 1 no. of each type |
| ix) Bearing and oil seals for | |
| a) Long retractable soot blower | 2 sets* |
| b) Water wall deslagger | 3 sets* |
| x) Complete steam safety valve assembly | 1 no. |
| xi) Steam control valve assembly | 1 no. |
| a) Stem and disc assembly for above | 2 sets* |
| b) Gaskets | 6 sets* |
| c) Gland packings | 4 sets* |
| d) Seat rings | 2 sets* |



xii) Long retractable soot blower assemblies complete	1 no. of each type
xiii) Limit switches	2 nos. of each type and rating
xiv) Complete power pack assembly for long retractable soot blower	2 nos. (1 no. for rotary + 1 no. for transverse)
xv) Spare set of rotary and transverse chain for long retractable soot blowers	1 no. of each type and size
xvi) Spares for rack gear assembly	
a) Set of gears and shaft (spur and worm)	1 set
b) Rack and pinion	1 set
xvii) Thermocouples for temperature probes	1 no. of each type and size

*One set means one complete replacement of one valve/equipment.

9.1.15 Valves

A) Steam drum safety valves

i) Upper adjusting ring	2 nos. of each type
ii) Lower adjusting ring	-do-
iii) Locking pin set	-do-
iv) Safety valve disc	-do-
v) Safety valve stem	1 no.
vi) Valve spindle	2 nos.
vii) Guide	1 no.

B) SH safety valves

i) Disc	2 nos. of each type
ii) Upper adjusting ring	2 nos.
iii) Lower adjusting ring	2 nos.
iv) Valve spindle	1 no.



- | | | |
|-------------------------------------|------------------------------------|---------------------|
| v) | Set of washers | 2 sets of each type |
| vi) | Guide | 1 no. of each type |
| vii) | Set of locking pins | 2 sets of each type |
| C) Hot RH safety valves | | |
| i) | Disc | 1 no. of each type |
| ii) | Upper adjusting ring | 1 no. of each type |
| iii) | Lower adjusting ring | -do- |
| iv) | Valve spindle | -do- |
| v) | Set of washers | 1 set of each type |
| vi) | Set of pins | 1 no. of each type |
| vii) | guide | 1 no. of each type |
| D) Cold RH safety valves | | |
| i) | Disc | 1 no. of each type |
| ii) | Upper adjusting ring | -do- |
| iii) | Lower adjusting ring | -do- |
| iv) | Valve spindle | -do- |
| v) | Locking pin set | 1 set of each type |
| vi) | Guide | -do- |
| vii) | Set of washers | 1 set |
| E) Electromatic relief valve | | |
| i) | Complete electromatic relief valve | 1 no. of each type |
| ii) | Spares for above: | |
| a) | Disc for main valve | 2 nos. of each type |
| b) | Spring for main valve | -do- |
| c) | Seal rings for main valve | -do- |



- d) Seal bushing for main valve -do-
- e) Disc and steam assembly for pilot valve -do-
- f) Bushing for pilot valve -do-
- g) Spring for pilot valve -do-
- h) Seal ring -do-

F) Superheater spray control valve

- i) Complete superheater spray control valve 4 nos. of each size and type
- ii) Spares for the above:
 - a) Gland packings set 4 sets
 - b) Pressure seal gasket 4 sets
 - c) Stem 2 nos.
 - d) Plug valve 2 nos.

G) Reheater spray control valve

- i) Complete reheater spray control valve 4 nos. of each size and type
- ii) Spares for the above:
 - a) Gland packings set 6 sets
 - b) Pressure seal gasket 6 sets
 - c) Stem 2 nos.
 - d) Plug valve 2 nos.

9.1.16 Superheater Spray Block Valve

- i) Gland packing set 2 sets of each type
- ii) Pressure seal gasket 2 nos. of each type
- iii) Stem 2 nos. of each type



- iv) Valve plug 2 nos. of each type

9.1.17 Reheater Spray Block Valve

- i) Gland packing set 2 sets of each type
ii) Pressure seal gasket 2 nos. of each type
iii) Stem 2 nos. of each type
iv) Valve plug 2 nos. of each type

9.1.18 Boiler Main Steam Stop Valve

- i) Set of gland packings 6 sets
ii) Pressure seal gaskets 8 nos.
iii) Stem 2 nos. of each type (1 no. for main valve and 1 no. for integral bypass valve)
iv) Disc -do-
v) Seat rings -do-
vi) Fastners -do-
vii) Actuator -do-

9.1.19 Boiler Feed Check Valve

- i) Body seat rings 1 no.
ii) Flap 1 no.
iii) Pressure seal ring 2 nos.
iv) Gland packings 2 sets
v) Fasteners 1 set



9.1.20 Start Up Vent Valves

i)	Stem	1 no.
ii)	Disc	1 no.
iii)	Body seat rings	2 sets
iv)	Gland packings	3 sets
v)	Pressure seal rings	3 nos.
vi)	Fasteners	1 set

9.1.21 Economiser Recirculation Valve

i)	Valve Stem	1 no.
ii)	Disc	1 no.
iii)	Body seat rings	1 set
iv)	Gland packings	2 sets
v)	Pressure seal rings	2 nos.

9.1.22 Auxiliary Steam Pressure Reducing and Desuperheating (PRDS) System

A) High capacity PRDS system (MS)

i)	Desuperheater liners	1 set
ii)	Pressure reducing cum desuperheating valves	
a)	Stem	1 no.
b)	Disc	1 no.
c)	Body seat rings	2 nos. for each type, size and rating of valves
d)	Gland packings	3 nos. for each type, size and rating of valves
e)	Pressure seal ring	3 nos.
f)	Gasket	3 nos.



- iii) Spray water line control valves
- Valve trim including cage, plug, stem, seat rings, guide bushings, stem packing
- 1 no. for each size, type and rating of valves

B) Low capacity PRDS system (CRH)

- i) Desuperheater liners 1 set
- ii) Pressure reducing cum desuperheating valves
- a) Stem 1 no.
- b) Disc 1 no.
- c) Body seat rings 2 nos. for each type, size and rating of valves
- d) Gland packings 3 nos. for each type, size and rating of valves
- e) Pressure seal ring 3 nos.
- f) Gasket 3 nos.
- iii) Spray water line control valves
- Valve trim including cage, plug, stem, seat rings, guide bushings, stem packing
- 1 no. for each size, type and rating of valves

9.1.23 Fuel Oil System

- i) Valves (gate, globe, check plug and ball valves) (For each type and size)
- a) 1 no. where total quantity of particular type and size of valve is less than or equal to 10
- b) 2 nos. where total quantity of a particular type and size of valve is less than 40 but more than 10
- ii) Steam trap 5 % of total number of each type and size of trap (in case of fractional quantity lower whole quantity shall be taken min qty.)



- iii) Pressure reducing valve 1 no.
- iv) Drain oil pump
 - a) Complete cartridge assembly 1 set
 - b) Mechanical seals 2 sets
 - c) Bearing (pump) 1 set
 - d) Set of all type of bushes and sleeve 2 sets
 - e) Set of 'O' rings and seals 2 sets
 - f) Set of gaskets 2 sets
 - g) Relief valve complete with accessories. 1 set

9.1.24 Variable Frequency Drive (VFD) System (if applicable)

- i) Electrical cards
 - a) Control modules 2 nos. of each type and rating
 - b) I/O module 2 nos. of each type and rating
 - c) Power supply modules 2 nos. of each type and rating
 - d) Thyristor gate module including gate transformer 100% of installed quantity
 - e) Exciter module 1 no.
- ii) Thyristor bridge leg 10%
- iii) Over voltage limiter and surge suppressor network 2 sets
- iv) Semi conductor fuses for thyristor 1 set
- v) Power and control fuse 100% of installed quantity
- vi) Control transformer 1 no. of each type and rating
- vii) Contactor/ breaker 2 nos.



viii)	CT/VT	1 no. of each type and rating
ix)	Indicating lamps	100% of each type and rating
x)	Auxiliary contactors and relays	15% of installed quantity
xi)	Panel mounted meters	1 no. of each type and rating
xii)	Panel mounted printer	1 no.
xiii)	Indicating lamp holder full set	15% of each type/colour
xiv)	Parameter tuning device	1 no.
xv)	<u>LT transformer (VFD)</u>	
	a) Bushings with metal parts and gaskets	
	• Primary	3 nos. each rating
	• Secondary	3 nos. each rating
	b) Winding temperature indicator with alarm and trip contacts	1 no.
	c) Oil temperature indicator with alarm and trip contacts	1 no.
	d) Magnetic oil level gauge	1 no.
	e) Pressure relief device	1 no.
	f) Diaphragm for explosion vent	1 no.
	g) Buchholz relay/ sudden pressure relay (as applicable)	1 no.
	h) Silica gel charge	3 charge
	i) Floats with contacts for buchholz relay	1 set
	j) Set of gaskets	2 sets
	k) Contacts tap changer	1 set
	l) Set of valves	1 set
	m) Pressure gauge (applicable for sealed tank)	1 no. each type



- n) Set windings for one limb in a suitable oil container 1 for each rating

9.1.25 Electrostatic Precipitator (ESP)

- i) Support insulator 6 nos.
- ii) Shaft insulator 6 nos.
- iii) Emitting electrodes
- a) Helical wire type 5% of the installed quantity in one ESP
- b) Wire pipe in rigid frame 10% of the installed quantity in one ESP
- c) Mast type 2% of the installed quantity in one ESP
- iv) Collecting electrode 2% of the installed quantity in one ESP
- v) Inner arm assembly 20 nos. each for collecting and emitting system
- vi) Outer arm assembly 10 nos. each for collecting and emitting system
- vii) Plain bearing 20 nos. of each type and size
- viii) Shock bar/ anvil 60 nos. of each type and size
- ix) Rappers
- a) For electric rappers
- Assembled rapper/ drop rods 20 nos. of each size and type
 - Coil assembly along with sleeve 4 nos.
 - Casing 4 nos.
 - Gaskets and packing 10 nos. of each size and type
- b) For tumbling rappers
- Hammers 20 nos. of each size and type
 - Bearing components 4 nos.



Section- 9 (Mandatory Spares)

- Shafts 4 nos.
 - Gear motors 4 nos.
- x) Transformer rectifier set
- a) Complete set 2 nos.
 - b) High voltage insulator 4 nos.
 - c) Switches and gaskets 1 set
(One set means one complete replacement for all the TR sets of one ESP)
- xi) Control system
- a) Transformer-rectifier set controller 2 nos.
 - b) Rapper controller complete 2 nos.
 - c) Communication controller complete 2 nos.
 - d) Electronic cards
 - For rapper controller and ESP management system 1 set
 - For transformer rectifier controller 2 sets
 - e) Display unit 2 nos. of each type
 - f) Keyboard 2 nos. of each type
 - g) Push buttons for:
 - TR set controller 2 sets
 - Others 1 set
 - h) Indicator lamps 1 set
 - i) Control fuse 1 set
 - j) Power fuse 1 set
 - k) Thyristor fuse 1 set
 - l) Thyristor of transformer rectifier controller 2 sets



- xii) MCC auxiliary control panel
- | | |
|---------------------------|--------|
| a) Breaker | 2 sets |
| b) Power contacts | 2 sets |
| c) Auxiliary relays | 1 set |
| d) Over load relay | 1 set |
| e) Power fuse | 1 set |
| f) Contact fuse | 1 set |
| g) Control terminal block | 1 set |



9.2 STEAM TURBINE AND AUXILIARIES (FOR EACH UNIT)

9.2.1 Steam Turbine

- | | | |
|-------|--|---------------------------|
| i) | Front bearing (complete set of bearing assembly including torous, intermediate pieces sole/ base plate and all other fixing/ assembly materials required to complete one bearing assembly except housing) | 1set |
| ii) | Front pedestal oil guard ring (complete set of oil guard assembly for front and rear with fixing material) | 1 set |
| iii) | High Pressure (HP) shaft seals (complete set of interstage seals of all the stages of moving blades of HP rotor with fixing material) | 1 set |
| iv) | HP shaft gland seals (complete set for replacement of front and rear with fixing material) | 1 set |
| v) | Sealing of HP casing assembly (1 set should comprise of sealing segments, fitted keys, pins, caulking material and interstage sealings of all the stationary rows) | 1 set |
| vi) | Sealing of HP inlet and HP exhaust assembly (sealing rings, lockwashers, connecting nuts/ capnuts between pipe and casing) | 1set |
| vii) | HP turbine first stage stationary and moving blades with assembly material | 1 set |
| viii) | HP outer and inner casing fasteners and fixing materials | 20% of each type and size |
| ix) | HP/IP combined thrust and journal bearing (complete with torous, intermediate pieces sole/base plate and all other fixing / assembly materials required to complete thrust and journal bearings assembly except housing) | 1 set |
| x) | HP/IP pedestal oil guard ring (complete set of oil guard assembly for front and rear with fixing material) | 1 set |
| xi) | HP/IP shaft coupling bolts, nuts, lock washers, pins, screws, coupling guards | 1 set |
| xii) | Sealing of IP casing assembly (1 set should consist of sealing segments, fitted keys, caulking material, pins, cap screws and interstage sealing of all the stationary rows) | 1 set |
| xiii) | IP turbine shaft seals (complete set of interstage seals of all the stages of moving blades of IP rotor with fixing material) | 1 set |



Section- 9 (Mandatory Spares)

xiv) IP shaft gland seals (complete set for replacement of front and rear with fixing material)	1 set
xv) IP turbine first stage stationary and moving blades with assembly materials	1 set
xvi) IP outer and inner casing fasteners and fixing materials	20% of each type and size
xvii) IP/LP journal bearing (complete with torous, intermediate pieces sole/base plate and all other fixing/assembly materials required to complete one bearing assembly except housing)	1 set
xviii) IP/LP pedestal oil guard rings (complete set of oil guard Assembly for front and rear with fixing material)	1 set
xix) IP/LP shaft coupling bolts, lock-washers, nuts, pins, screws, coupling guards	1 set
xx) LP turbine rear bearing (complete set of bearing assembly including torous, intermediate pieces sole/base plate and all other fixing/assembly materials required to complete one bearing assembly without housing)	1 set
xxi) LP turbine atmospheric diaphragm (complete set for replacement of one diaphragm assembly)	1 set
xxii) LP shaft seals (complete set of interstage seals of all the stages of LP rotor with fixing materials)	1 set
xxiii) LP shaft gland seals (complete set for replacement of front and rear with fixing materials)	1 set
xxiv) LP turbine rotor moving blades of last 3 stages for each path with all the fastening material required for the above	1 set
xxv) LP outer and inner casing fasteners fixing materials	20% of each type and size
xxvi) Turbine and generator shaft journal bearings (complete set of bearing assembly including torous, intermediate pieces sole/base plate and all other fixing/assembly materials required to complete each bearing assembly except housing)	1 set
xxvii) LP turbine and generator shaft coupling bolts, nuts, lock washers, pins, screws, coupling guard.	1 set



9.2.2 Emergency Stop Valves

- | | | |
|------|---|-------|
| i) | Set of all internals required to complete one valve assembly excluding valve body | 1 set |
| ii) | Set of all internals required to complete one servomotor assembly excluding body | 1 set |
| iii) | Set of all internals required to complete one test valve servomotor assembly excluding body | 1 set |

9.2.3 HP Control Valves

- | | | |
|------|---|-----------------------------|
| i) | Set of all internals required to complete one valve assembly except valve body | 1 set |
| ii) | Set of all internals required to complete one servomotor assembly except servomotor body | 1 set |
| iii) | Set of all internals required to complete one pilot valve assembly except body) | 1 set of each type and size |
| iv) | Set of mounting arrangement for position transmitter for one HP control valve (complete set comprising of bellows, pins, bushes, couplers, lock washers, position detector) | 1 set |

9.2.4 IP Stop Valves

- | | | |
|------|---|-------|
| i) | Set of all internals required to complete one valve assembly excluding valve body | 1 set |
| ii) | Set of all internals required to complete one servomotor assembly excluding body | 1 set |
| iii) | Set of all internals required to complete one test valve assembly except valve body | 1 set |

9.2.5 IP Control Valves

- | | | |
|------|--|-------|
| i) | Set of all internals required to complete one valve assembly except valve body | 1 set |
| ii) | Set of all internals required to complete one servo motor assembly except body | 1set |
| iii) | Set of all internals required to complete one pilot valve assembly except body | 1set |



	iv) Set of mounting arrangement for position transmitter for one IP control valve (Complete set comprising of bellows, bushes, couplers, pins, lock washers, position detector)	1 set
9.2.6	Drain Valves with Actuators	10% of each type and size
9.2.7	Gland Steam System	
	i) Turbine gland steam supply valves (complete set of internals required to form one valve assembly except outer body)	1set
	ii) Turbine gland steam leak-off valves (complete set of internals required to form one valve assembly except for outer body)	1 set
	iii) Valves for gland steam seal system	1 no. of each type and size
9.2.8	Turning Gear	
	i) Gear internal with shafts, bearing, bushes, lock washers, oil seals, 'O' rings	1 set
	ii) 25% nozzle segments and moving blades and complete set of sealing strips with caulking material (if hydraulically operated)	1 set
9.2.9	Turbine Governing and Protection System	
	i) Hydraulic speed governor (complete set of internals required to form one speed governor assembly except for outer casing)	1set
	ii) Electro hydraulic converter for governing system (complete set of internals required to form one convertor assembly except for outer casing)	1set
	iii) Follow up pistons for governing system (complete replacement in governing system of one turbine)	20% of each type and size
	iv) Hydraulic amplifier for governing system (complete set of internals required to form one hydraulic amplifier assembly except for outer casing)	1 set
	v) Over speed trip testing device (complete set of internals required to form one device assembly except outer body)	1 set
	vi) Main trip valve assembly	1 no.



vii)	Release valve for main trip valve	1 no.
viii)	Bellow for accumulators in governing system (set comprising of complete replacement in one TG unit)	1 set
ix)	Emergency governor	1 no.
x)	Gear for loading device (complete set consisting of gear for loading device and its motor and all other fixing/assembly materials except housing)	1set
xi)	Gear for startup device (complete set consisting of bushes, spring, motor and all other fixing/assembly materials except housing)	1set

9.2.10 Turbine Lubricating Oil System

i)	Shaft driven main oil pump (complete set consisting of impeller, shaft, key, impeller nut, wear rings, journal bearings, thrust bearing, coupling, shaft sleeves, oil seals, 'O' rings as required for one pump)	1 set
ii)	Auxiliary oil pumps (set comprising of pump or pumps alongwith motor required to meet the 100% operational requirements of one TG unit)	1 set
iii)	DC emergency oil pump including motor (set comprising of pump or pumps alongwith motor required to meet the 100% operational requirement of one TG unit)	1 set
iv)	Jacking oil pump including motor (set comprising of pump or pumps alongwith motor required to meet the 100% operational requirements of one TG unit)	1 set
v)	Transfer oil pumps (set comprising of pump or pumps alongwith motor required to meet the 100% operational requirements of one TG unit)	1 set
vi)	Oil tank vapour extractors with motor (for each type and size)	1 set
vii)	Lube oil coolers (for each type and size) Seals, gaskets, 'O' rings etc.	2 sets
viii)	Duplex oil filters/ strainers (for each type and size) (complete set consisting of cartridges, gaskets, 'O' rings except housing)	2 sets



ix)	Oil purifier	
	a) Bearings including motor bearings	1 set
	b) Bag filters	4 sets
	c) Cartridge filters	4 sets
	d) Gaskets	2 sets
	e) Dust seats and 'O' rings for motors	2 sets
9.2.11	Turbine Control Fluid System	
i)	Control fluid pumps including motor (set comprising of pump or pumps alongwith motor required to meet the 100% operational requirement of one TG unit)	1 set
ii)	Control fluid vapour exhauster with motor	1 set
iii)	Control fluid coolers' seals, gaskets, and 'O' rings etc.	2 sets
iv)	Duplex oil filters/ strainers (complete set consisting of cartridges, gaskets, 'O' rings except housing)	2 sets
v)	Control fluid purifier	
	a) Bearings including motor bearings	1 set
	b) Bag filters	4 sets
	c) Cartridge filters	4 sets
	d) Gaskets	2 sets
	e) Dust seals and 'O' rings for motors	2 sets
9.2.12	Turbine Thrust Bearings Trip Device	1 set
	(complete set consisting of springs, bellow assembly, limit switch, pilot valve, gasket, latch spindle, pins, 'O' rings)	
9.2.13	Automatic Turbine Testing Changeover Valve	1 set
	(complete set of internals required to form one change over valve assembly except for outer casing)	



9.2.14 HP Bypass System

- i) Control valves
 - a) Complete set of internals required to form one valve assembly except for outer body 1 set
 - b) Complete set of internals required to form one servomotor assembly except for outer body 1 set
 - c) Complete set of internals required to form one pilot valve assembly except for outer body 1set
- ii) Water injection valves
 - a) Complete set of internals required to form one injection valve assembly except for outer body 1 set
 - b) Complete set of internals required to form one pilot valve assembly except for outer body 1 set
- iii) Bellow for accumulators 1 set

9.2.15 LP Bypass System

- i) Stop valves
 - a) Complete set of internals required to form one valve assembly except for outer body 1 set
 - b) Complete set of internals required to form one servomotor assembly except for outer body 1 set
- ii) Control valves
 - a) Complete set of internals required to form one valve assembly except for outer body 1 set
 - b) Complete set of internals required to form one servomotor assembly except for outer body 1 set
 - c) Complete set of internals required to form one pilot valve 1set
- iii) Water injection valves
 - a) Complete set of internals required to form one injection valve assembly except for outer body 1 set



	b) Complete set of internals required to form one pilot valve assembly except for outer body	1 set
	iv) Bellow for accumulators	1 set
8.2.16	NRVs on CRH Line	
	i) Complete set of internals required to form one valve assembly except for outer casing	1 set
	ii) Servomotor for NRV (complete set of internals required to form one servomotor assembly except outer body)	1 set
	iii) Changeover valve for NRV (complete set of internals required to form one changeover valve assembly except outer body)	1 set
9.2.17	NRVs on Extraction Lines (for each type and size)	
	i) Complete set of internals required to form one valve assembly except for outer casing	1 set
	ii) Actuators for one NRVs	1 set
9.2.18	HP Heaters (for each HP heater)	
	i) Shell side safety relief valve	2 nos.
	ii) Tube side sentinel valve	2 nos
	iii) Instrumental source valve	1 set
	iv) Vent orifice	1 set
	v) Gasket	2 sets
	vi) Tube plugs	10%
	vii) Level gauge glass with packing	2 nos.
9.2.19	LP Heaters (for each LP heater)	
	i) Shell side safety relief valve	1 no.
	ii) Tube side sentinel valve	1 no.
	iii) Instrumental source valve	1 set
	iv) Vent orifice	1 set



v)	Gaskets	2 sets
vi)	Tube plugs	10%
vii)	Level gauge glass with packing	1 no.
9.2.20	Gland Steam Condenser	
i)	Level gauge glass with packing	1 no.
ii)	Tube side sentinel valve	1 no.
9.2.21	Drain Cooler	
i)	Level gauge glass with packing	1 no.
ii)	Instrumental source valve	1 set
iii)	Gasket	2 sets
iv)	Tube plugs	10 nos.
9.2.22	Deaerator	
i)	Spray nozzles	10% of each type and size
ii)	Trays	5% of each type and size
iii)	Level gauge glass with packing	1 no.
iv)	Instrumental source valve	1 set
v)	Vent orifice	1 set
vi)	Gaskets	2 sets
9.2.23	Steam Dumping Device	1 set of each type and size
	(complete set consisting of internals required to form one dumping device assembly except for outer body)	
9.2.24	Condenser	
i)	Low vacuum condenser protection device (set of internals required to complete one protection device assembly except for housing)	1 set



ii)	Condenser vacuum breaker valve	1 no.
iii)	Condenser manhole cover gaskets (set comprising of complete replacement for one condenser)	1 set
iv)	Level gauge glass with packing	1 no.
v)	Instrumental source valve	1 set
vi)	Condenser tubes	10%
vii)	Tube plugs	10%
viii)	Gaskets	2 sets
ix)	Nozzles for ejector of vacuum pump (set comprising of complete replacement for one vacuum pump)	1 set
x)	Condenser air evacuation pump (complete set of spare internals required to form one pump except for pump body)	1 set

9.2.25 Condenser On- Line Tube Cleaning System

i)	Sponge rubber balls for condenser on-load tube cleaning system	50,000 nos.
ii)	Ball circulating pumps (set consisting of shaft, rotor, bearings, seals, gland package shafts sleeves for complete replacement in one pump)	1 set

9.2.26 Boiler Feed Pumps

i)	Turbine drive	
a)	One set of regulating stage blades alongwith all fastening material, if applicable.	1 set
b)	One set of LP blades (only last stage) alongwith all fastening material.	1 set
c)	One set of journal bearings and thrust bearing including liners	1 set
d)	One set of emergency overspeed governor (in case overspeed governor is provided)	1 set
e)	One set of speed probe, extension cable, proximito and monitor (in case electronic overspeed protection is provided)	1 set



f)	One set of emergency stop and control valves (excluding servo-drives and switch boxes)	1 set
g)	Gear internals with shafts bearings, bushes, lock washers, oil seals 'O' rings	1 set
ii) Main pumps		
a)	Thrust bearing tilting pad with thrust collar	1 set*
b)	Sleeve bearings insert and liners	1 set*
c)	Wear ring set (rotating and stationary)	1 set*
d)	Balancing drum and balancing drum head	1 set*
e)	Mechanical seal	1 set*
f)	Gaskets and 'O' rings	2 sets*
g)	Seal sleeves	1 set*
iii) Booster pumps		
a)	Thrust bearing and thrust collar	1 set*
b)	Sleeve bearings insert and liners	1 set*
c)	Wear ring set (rotating and stationary)	1 set*
d)	Mechanical seal	1 set*
e)	Gaskets and 'O' rings	2 set*
f)	Seal sleeves	1 set*
iv) Reduction gear		
a)	Bearings	1 set*
b)	Gaskets and washers etc.	2 sets
v) Fluid coupling		
a)	Radial bearings	1 set*
b)	Tilting pad thrust bearing	1 set*
c)	Gaskets, 'O' rings, lock washers and split pins etc.	2 sets*



- vi) BFP motor
 - a) Bearings 1 set*
 - b) Dust seal and gaskets etc. 2 sets*

9.2.27 Lubricating Oil System for Motor Driven BFP

- i) Lubricating oil pumps (set comprising of pump or pumps alongwith motor required to meet the 100% operational requirements of one motor driven BFP) 1 set*
- ii) DC emergency oil pump (set comprising of pump or pumps alongwith motor required to meet the 100% operational requirement of one motor driven BFP) 1 set*
- iii) Lub oil/ working oil coolers (for each type and size) Seals, gaskets, 'O' rings etc. 2 sets*
- iv) Duplex oil filters/ strainers (for each type and size) (complete set consisting of cartridges, gaskets, 'O' rings except housing) 2 sets*

9.2.28 Lubricating Oil System for Turbine Driven BFPs

- i) Auxiliary oil pumps (set comprising of pump or pumps alongwith motor required to meet the 100% operational requirements of one turbine driven BFP) 1 set*
- ii) DC emergency oil pump including motor (set comprising of pump or pumps alongwith motor required to meet the 100% operational requirement of one turbine driven BFP) 1 set*
- iii) Jacking oil pump including motor (set comprising of pump or pumps alongwith motor required to meet the 100% operational requirements of one turbine driven BFP), if applicable 1 set*
- iv) Transfer oil pumps (set comprising of pump or pumps alongwith motor required to meet the 100% operational requirements of one turbine driven BFP) 1 set*
- v) Oil tank vapour extractors with motor (for each type and size) 1 set*
- vi) Lube oil coolers (for each type and size) Seals, gaskets, 'O' rings etc. 2 sets*
- vii) Duplex oil filters/ strainers (for each type and size) (complete set consisting of cartridges, gaskets, 'O' rings except housing) 2 sets*



- viii) Oil purifier
 - a) Bearings including motor bearings 1 set*
 - b) Bag filters 4 sets*
 - c) Cartridge filters 4 sets*
 - d) Gaskets 2 sets*
 - e) Dust seats and 'O' rings for motors 2 sets*

Note: *One set means complete replacement for one Pump.

9.2.29 Condensate Extraction Pumps (CEPs)

- i) Complete thrust bearings 1 set*
- ii) Radial bearings including bushes 1 set*
- iii) Journal pads of thrust bearing 2 sets*
- iv) Wearing rings comprising of suction and stage impeller, neck rings, casing wear ring. 1 set*
- v) Coupling between motor and pump 1 set*
- vi) Suction strainer 1 no.
- vii) Set of impellers (one set comprises of complete replacement required for one CEP) 1 set*

Note: *One set means complete replacement for one Pump.

9.2.30 Condensate Polishing Unit

- i) Service and regeneration vessels (for each type and size)
 - a) Diffusers, distributors and nozzles 10%
 - b) Perforated laterals and under drain collectors 10%
 - c) Gaskets etc. 2 sets
 - d) Nuts and bolts etc. 1 set
- ii) Resin traps 1 no. of each type and size



iii) Valves	20% of each type and size
iv) Pumps and blowers alongwith drive motors	1 no. of each type and size
v) Resin transfer hoppers	1 no. of each type and size
vi) Ejectors/ dosing pumps	1 no. of each type and size
vii) Storage, preparation and metering tanks etc.	(for each type and size)
a) Tank stirrers (as applicable)	1 set
b) Dissolving baskets (as applicable)	1 set
c) Heating element (as applicable)	1 set
d) Gaskets etc.	2 sets
e) Nuts and bolts etc.	1 set
viii) Resins	20% of the total filled volume for each resin

9.2.31 Debris Filters (if applicable)

i) Filter element seating component	1 set
ii) Actuators alongwith motors	1 set
iii) Debris discharge and other valves	1 set
iv) Gaskets etc.	2 sets
v) Wetted nuts and bolts etc.	1 set
vi) Other nuts and bolts etc.	20%



9.3 PIPING, VALVES, THERMAL INSULATION AND MISCELLANEOUS SYSTEMS/ EQUIPMENTS

9.3.1 Power Cycle Piping System

S. No.	Description	Quantity
i)	Spare gaskets for all the gate valve for sizes 15 mm NB to 500 mm NB	100% of each type, size and class
ii)	Spare sets of gland packings of all the gate valves for all sizes	- do-
iii)	Spare gaskets for all the globe valves for sizes 15 mm NB to 500 mm NB	- do-
iv)	Spare sets of gland packings for all the globe valves for all sizes	- do-
v)	Spare gaskets for all NRVs	- do-
vi)	Spare set of gaskets for safety relief valves, for all sizes	- do-
vii)	Complete gate valves assembly upto the size of 50 NB	100% of each type, size and class
viii)	Complete angle valves only upto the size of 50 NB	- do-
ix)	Complete globe valves up to the size of 50 NB	- do-
x)	Complete NRV's assembly upto the size of 50 NB	- do-
xi)	Complete needle valves upto the size of 50 NB	- do-
xii)	Spring hangers (variable spring and constant spring hangers)	10% of total population of one (1) unit for each type and stiffness with minimum one (1) no.
xiii)	Gasket for each flanged connection on high pressure steam and feed line	2 nos.



xiv)	Steam traps and Y type strainers All internals required to complete one full assembly, except body	10% of total population of one (1) unit for each size, type and rating, or minimum one (1) set
xv)	Other valves	
a)	Each type, size and class for 100 mm and below but above 50 NB	1 no.
b)	Each type, size and class above 100 mm	20% or 2 nos. whichever is higher
9.3.2	Thermal Insulation, Refractory, Lagging and Cladding	5% of the total quantity/ population used for each type, size and class with minimum 2 nos.
9.3.3	Low Pressure Piping System	
	Valves	5% of the total population of each type, size and class or minimum 2 nos. of each type, size and class whichever is higher
9.3.4	Equipment Cooling Water (ECW) System	
i)	DMCCW pumps for TG auxiliaries (as required for one pump)	
a)	Impellers	1set
b)	Wearing rings	1 set
c)	Pumps bearings	1 set
d)	Motor bearings	1 set
e)	Pump shaft	1 set
f)	Shaft sleeves	1 set
g)	Gaskets, dust seals and 'O' ring etc.	2 sets
h)	Nut and bolts etc.	1 set
i)	Mechanical seal	1 set



ii)	DMCCW pumps for SG auxiliaries	(as required for one pump)
a)	Impellers	1set
b)	Wearing rings	1 set
c)	Pumps bearings	1 set
d)	Motor bearings	1 set
e)	Pump shaft	1 set
f)	Shaft sleeves	1 set
g)	Gaskets, dust seals and 'O' ring etc.	2 sets
h)	Nut and bolts etc.	1 set
i)	Mechanical seal	1 set
iii)	Secondary cooling water pumps	(as required for one pump)
a)	Impellers	1set
b)	Wearing rings	1 set
c)	Pumps bearings	1 set
d)	Motor bearings	1 set
e)	Pump shaft	1 set
f)	Shaft sleeves	1 set
g)	Gaskets, dust seals and 'O' ring etc.	2 sets
h)	Nut and bolts etc.	1 set
i)	Mechanical seal	1 set
iv)	Heat exchangers for TG auxiliaries	
a)	Gaskets etc.	2 sets
b)	Nut and bolts etc.	1 set
c)	Plates	10%



- v) Heat exchangers for SG auxiliaries
 - a) Gaskets etc. 2 sets
 - b) Nut and bolts etc. 1 set
 - c) Plates 10%
- vi) Self cleaning filters
 - a) Filter element 1 set
 - b) Actuators alongwith motors 1 sets
 - c) Debris discharge and other valves 1 sets
 - d) Gaskets etc. 2 sets
 - e) Nut and bolts etc. 1 set

9.3.5 HP and LP Chemical Dosing Systems

A) Phosphate dosing system

- i) Dosing pumps and drives 1 No. of each type and size
- ii) Agitators 1 No. of each type and size
- iii) Reduction gear assembly 1 No. of each type and size
- iv) Strainers 1 No. of each type and size
- v) Valves 1 No. of each type and size

B) Hydrazine dosing system

- i) Dosing pumps and drives 1 No. of each type and size
- ii) Agitators 1 No. of each type and size
- iii) Reduction gear assembly 1 No. of each type and size
- iv) Strainers 1 No. of each type and size
- v) Valves 1 No. of each type and size

C) Ammonia dosing system

- i) Dosing pumps and drives 1 No. of each type and size



ii) Agitators	1 No. of each type and size
iii) Reduction gear assembly	1 No. of each type and size
iv) Strainers	1 No. of each type and size
v) Valves	1 No. of each type and size

9.3.6 EOT Crane

i) Carbon brushes for each motor	3 sets
ii) Brush holders for each motor	1 set
iii) Bearing for each motor	1 set
iv) Bearings for each reduction gear unit	1 set
v) Bearings for cross travel and long travel wheels	1 set
vi) Linings for each brake shoe complete with rivets	2 sets
vii) Contactors of each type and rating	2 nos. each
viii) Timers of each type	2 nos. each
ix) Limit switches and switches of each type	1 set each
x) Sockets of each type	1 set each
xi) Double roller collectors	3 sets
xii) Porcelain insulators of each type	2 sets each
xiii) Contacts for master controllers	2 sets
xiv) Brake springs for main and auxiliary hoist brakes	3 sets
xv) Coils for all contactors	1 set each

9.3.7 Electric Hoists

i) Brake linings	2 sets of each type
ii) Rope guide and rope tightener	1 no. of each type
iii) Limit switch	2 nos. of each type and size



9.3.8 Elevators

A) Elevators for main plant building

i)	Friction block	2 nos.
ii)	Guide roller of each type	20% of total population or 3 nos. whichever is higher
iii)	Contactors of each type	2 nos.
iv)	Control transformer	1 no. of each type
v)	Time device	2 nos. of each type
vi)	Rectifiers	2 nos. of each type
vii)	Overcurrent relay	2 nos. of each type
viii)	Auxiliary relay	3 nos. of each type
ix)	Resistor	3 nos. of each type
x)	Fuses of each rating	20% of the total population
xi)	Limit switches of each type	3 nos.
xii)	Push button	3 nos. of each type
xiii)	Contact device (if applicable)	3 nos. of each type
xiv)	Brake motor	2 nos. of each type
xv)	Transmitters	2 nos. of each type
xvi)	Switches of each type	3 nos.
xvii)	Receiver	2 nos. of each type
xviii)	Bearings of each type and size	2 nos.
xix)	Roller of each type	3 nos.
xx)	<u>Spares for worm gear</u>	
a)	'O' rings	3 sets



b)	Sealing ring of each type	3 sets
xxi)	<u>Spares for brake</u>	
a)	Fan	2 nos. of each type
b)	Magnetic coil	3 nos. of each type
c)	Brake disc	2 sets
d)	Brake pad	2 sets
xxii)	Bushing (for door front)	2 sets
xxiii)	Pinion	2 nos. of each type
B)	Elevators for boiler area	
i)	Friction block	2 nos.
ii)	Guide roller of each type	20% of total population or 3 nos. whichever is higher
iii)	Contactors of each type	2 nos.
iv)	Control transformer	1 no. of each type
v)	Time device	2 nos. of each type
vi)	Rectifiers	2 nos. of each type
vii)	Overcurrent relay	2 nos. of each type
viii)	Auxiliary relay	3 nos. of each type
ix)	Resistor	3 nos. of each type
x)	Fuses of each rating	20% of the total population
xi)	Limit switches of each type	3 nos.
xii)	Push button	3 nos. of each type
xiii)	Contact device (if applicable)	3 nos. of each type
xiv)	Brake motor	2 nos. of each type



xv)	Transmitters	2 nos. of each type
xvi)	Switches of each type	3 nos.
xvii)	Receiver	2 nos. of each type
xviii)	Bearings of each type and size	2 nos.
xix)	Roller of each type	3 nos.
xx)	<u>Spares for worm gear</u>	
a)	'O' rings	3 sets
b)	Sealing ring of each type	3 sets
xxi)	<u>Spares for brake</u>	
a)	Fan	2 nos. of each type
b)	Magnetic coil	3 nos. of each type
c)	Brake disc	2 sets
d)	Brake pad	2 sets
xxii)	Bushing (for door front)	2 sets
xxiii)	Pinion	2 nos. of each type
C)	Elevators for service building	
i)	Friction block	2 nos.
ii)	Guide roller of each type	20% of total population or 3 nos. whichever is higher
iii)	Contactors of each type	2 nos.
iv)	Control transformer	1 no. of each type
v)	Time device	2 nos. of each type
vi)	Rectifiers	2 nos. of each type
vii)	Overcurrent relay	2 nos. of each type



Section- 9 (Mandatory Spares)

viii)	Auxiliary relay	3 nos. of each type
ix)	Resistor	3 nos. of each type
x)	Fuses of each rating	20% of the total population
xi)	Limit switches of each type	3 nos.
xii)	Push button	3 nos. of each type
xiii)	Contact device (if applicable)	3 nos. of each type
xiv)	Brake motor	2 nos. of each type
xv)	Transmitters	2 nos. of each type
xvi)	Switches of each type	3 nos.
xvii)	Receiver	2 nos. of each type
xviii)	Bearings of each type and size	2 nos.
xix)	Roller of each type	3 nos.
xx)	<u>Spares for worm gear</u>	
	a) 'O' rings	3 sets
	b) Sealing ring of each type	3 sets
xxi)	<u>Spares for brake</u>	
	a) Fan	2 nos. of each type
	b) Magnetic coil	3 nos. of each type
	c) Brake disc	2 sets
	d) Brake pad	2 sets
xxii)	Bushing (for door front)	2 sets
xxiii)	Pinion	2 nos. of each type

Note: Similar spares shall be included for other elevators supplied, if any.



9.3.9 Air Conditioning System

- i) Reciprocating chilling machine
 - a) Compressors with motors 1 no.
 - b) Piston 1 set
 - c) Valve plate, spring plate, seating washer 4 nos.
 - d) Suction and discharge valve required for compressors 1 set
 - e) Piston ring/guide ring 6 sets
 - f) V-belts for compressor 4 sets
 - g) Oil pressure failure safety switch 2 nos.
 - h) Crank-case heater 2 nos.
 - i) Gaskets 2 sets
 - j) Set of 'O' rings and oil seals each type 2 sets
 - k) Suction filter elements 4 sets
 - l) Bearings 2 sets
 - m) Complete set of suction valves 2 sets
 - n) Complete set of discharge valves 2 sets
- ii) Screw compressor chilling machine
 - a) Oil filter 1 set
 - b) Oil filter 'O' ring 1 set
 - c) Refrigerant filter 1 set
 - d) Ref filter 'O' ring 1 set
 - e) EXV valve 1 no.
 - f) Differential pressure switch 1 no.
 - g) Solenoid valve 2 way 1 no.



Section- 9 (Mandatory Spares)

h)	Solenoid valve coil	1 set
i)	Solenoid valve 'O' ring	1 set
j)	Solenoid valve gasket	1 set
k)	Master solenoid valve	1 no.
l)	Master solenoid valve coil	1 set
m)	Master solenoid gasket	1 set
iii)	Air handling unit (for each model)	
a)	Impeller/ blower with motor	1 no.
b)	V-belts for AHU blower	4 sets
c)	AHU blower bearing	2 sets
d)	Blower motor bearing	2 sets
e)	Filters at suction and discharge of AHU	50% of installed population
iv)	Controls (for each model)	
a)	HP/LP cut out	1 no.
b)	Anti-freeze thermostat	2 nos.
v)	Cooling tower (for each model)	
a)	Nozzles for cooling towers	20 nos.
b)	Float valve assembly	1 no.
c)	Fan bearings	1 set
d)	Motor bearings	1 set
e)	V-belt for cooling tower fan (if applicable)	1 set
vi)	Valves (for each type and size)	
a)	One (1) no. where total quantity of a particular type and size of valve is less than or equal to ten (10).	



- b) Two (2) nos. where total quantity of a particular type and size of valve is less than 40 but more than 10.
- c) 10% of the total quantity (to nearest whole no. of a particular type and size where the total quantity of a particular type and size of valve is more than 40.
- vii) Humidity sensors 1 no.
- viii) Geysersstat 2 nos.
- ix) Antifreeze thermostat 1 no.
- x) Local humidity indicator 1 no.

9.3.10 Ventilation System

- i) Air washer units
- a) Supply air fans
- Air fan 1 no.
 - V-belts 4 sets
 - Bearings 2 set
- b) Air washer pumps
- Pump set alongwith motor 1 no.
 - Pump impeller 1no.
 - Pump bearing 2 set
 - Shaft sleeves 4 nos.
 - Gland packings 4 nos.
- c) Metallic/ fabric panel filters, as applicable 1 set (quantity for one no. of air washer)
- d) Spray nozzles 5% of total population or 10 nos. whichever is higher.
- e) Flooding nozzles if applicable 5 % of total population or 2 nos. whichever is higher.
- f) Air Washer Pump inlet water strainer 1 no.



- | | | |
|------|--|--|
| g) | Brass suction/screen strainer for air water tank | 1 set |
| ii) | Unitary air filtration unit (for each model and capacity) | |
| a) | Supply air fans | |
| | • Air fan | 1 no. |
| | • V-belts | 2 sets |
| | • Bearings | 1 set |
| b) | UAF pumps | |
| | • Pump set alongwith motor | 1 no. |
| | • Pump impeller | 1no. |
| | • Pump bearings | 1 set |
| | • Shaft sleeves | 2 nos. |
| | • Gland packings | 2 sets |
| c) | Nylon filters | 1 set |
| d) | Spray nozzles | 5% of total population
or 10 nos. whichever is
higher. |
| e) | Flooding nozzles if applicable | 5 % of total population
or 2 nos. whichever is
higher. |
| f) | Water strainer | 1 no. |
| g) | Brass suction screen/ strainer for
unitary air filtration unit tank | 1 set |
| iii) | Mechanical ventilation system | |
| a) | Roof exhauster fans
(for each type, rating and capacity) | 5% of total population or
1 no. whichever is
higher. |
| b) | Supply air fans (wall mounted)
(for each type, rating and capacity) | 5% of total population or
1 no. whichever is
higher. |



- | | | |
|----|---|---|
| c) | Exhaust fans (wall mounted)
(for each type, rating and capacity) | 5% of total population or
1 no. whichever is
higher |
|----|---|---|

- | | | |
|---------------|---|--|
| 9.3.11 | Miscellaneous valves
(Specifically not covered above) | 10% of each type and
size with minimum one
(1) no. |
|---------------|---|--|



9.4 ELECTRICAL SYSTEM (FOR EACH UNIT)

<u>Sl. No.</u>	<u>Description</u>	<u>Quantity</u>
9.4.1	Generator and Auxiliaries	
9.4.1.1	Generator	
i)	Gaskets of all type (one set should include all types and sizes of gaskets for one generator and auxiliaries)	1 set
ii)	Insulating packer below slot wedges	50% of slot nos.
iii)	Ripple springs	50%
iv)	Liners (Insulating material below the retaining rings)	1 set
v)	Spacers (Insulating material below the retaining rings)	1 set
vi)	Generator bearings for Turbine End (TE) and Exciter End (EE) (complete with torous, intermediate pieces and all other fixing/ assembly material required to complete one TG unit except housing)	1 set
vii)	Oil guard rings spare for TE and EE bearings	1 set
viii)	Brush holder of each type (one set should include all types and sizes of brush holder for one generator exciter) (details of quantity)	1 set
ix)	Carbon brush	2 sets
x)	Slipring with brush	1 no.
xi)	Stator winding bars and connections (one set comprising of two bars of each variant)	1 set
xii)	Slot wedges	100%
xiii)	Hydrogen seals rings TE, EE each for phase and neutral side	2 sets
xiv)	Set of Teflon Hoses with connectors (for stator water cooling system)	50% of the no. of slots
xv)	Retaining rings (unmachined)	1 pair set
9.4.1.2	Brushless excitation system	
i)	Relays of each type	1 no.
ii)	Electronic control card of each type	1 no.
iii)	Control transformer of each type/rating	1 set
iv)	Diode with fuses	25% of one unit
v)	Thyristors	100% of one unit
9.4.1.3	Gas system	
i)	Diaphragm valve of each type	1 no.
ii)	Gas valves of each type and sizes (other than item no.c)	1 no.
iii)	Valves for H ₂ and CO ₂ manifolds	2 nos.
iv)	Safety valve	2 nos.



v)	H ₂ gas regulator from cylinder to manifold	3 nos.
vi)	CO ₂ gas regulator from cylinder to manifold	3 nos.
vii)	Temperature and Pressure switch of each type	1 no.
viii)	Bearings and seals for fan and gas drier	1 set
ix)	Thermostat for gas drier	1 no.
x)	Dessicant for gas drier	1 complete fill
xi)	Thermometers of each type and range	1 no.
xii)	Filter for gas analyser	2 sets
9.4.1.4 Seal oil system		
i)	Complete motor and Pump assembly for AC seal oil pump of each type	1 no.
ii)	Motor pump set for DC seal oil pump	1 no.
iii)	Pump and motor bearings	1 set
iv)	Screw pump (bearings rotating elements)	1 set
v)	Vacuum motor pump set	1 no.
vi)	Differential pressure regulator	1 no.
vii)	Non-return shut off valves of each type	1 no.
viii)	Float valve of each type	1 no.
ix)	Non-return valve of each type	1 no.
x)	Filter elements	2 nos.
xi)	Vacuum pressure gauge	2 nos.
xii)	Differential pressure	1 no.
xiii)	Bellow for differential pressure regulator	2 set
xiv)	Vacuum valves of each size and type	1 no.
9.4.1.5 Seal oil pressure measuring equipment		
i)	Amplifier circuit board	1 no.
ii)	Calibration circuit board	1 no.
iii)	Sensor module	1 no.
iv)	'O' rings	1 no.
v)	Isolating cocks of different type	1 set
vi)	Pressure transmitter	1 no.
vii)	Limit valve monitor	1 no.
9.4.1.6 Stator water cooling system		
i)	Pump Impeller	1 no.
ii)	Motor	1 no.
iii)	Float for level regulator	1 nos.
iv)	Filter elements	2 sets
v)	S.S. 3 way cock	1 no.
vi)	All type of valves in stator water cooling system of each size and type	1 no.
vii)	Ferro-dynamic indicator	1 set
viii)	Level signalling device	1 set
ix)	Specific resistance measuring	1 set



Section- 9 (Mandatory Spares)

x)	Insulators for stator water header	1 set
xi)	Pressure gauge of each type and size	1 no.
9.4.1.7	Local panels for generator auxiliary	
i)	Indicating instruments of each type and size	1 no.
ii)	Pressure and temperature switches	20% of the total population or minimum 2 nos.
iii)	Indicating lamps	100% of the population
9.4.2	Generator Isolated Phase Busducts (IPBD) and Neutral Grounding System	
i)	Bus support insulator	5% of total population
ii)	Flexible terminal connector complete with Hardware for	
	a) Generator	3 sets
	b) Generator Transformer	3 sets
	c) Unit Transformer	3 sets
	d) VT and SP Cubicle Tap off	3 sets
iii)	Seal off bushings suitable for	
	a) Main run	1 no.
	b) Tap off run	1 no.
	c) Individual Tap off run	1 no.
iv)	Current transformer of each type and rating	3 nos.
v)	Voltage Transformer of each type and rating	3 nos.
vi)	VT primary fuse of each type and rating	10 nos.
vii)	VT secondary MCBs/ fuse of each type and rating	10 nos.
viii)	Lighting arrester of each type and rating	3 nos.
ix)	Expansion Bellow of each type and rating	3 sets
x)	Flexible connectors for neutral grounding equipment	2 sets
9.4.3	Power Transformer	
9.4.3.1	Generator transformer	
i)	HV Bushing with metal parts and gaskets	3 nos.
ii)	LV bushing with metal parts and gaskets	3 nos.
iii)	HV Neutral bushing with metal parts and gaskets	1 no.
iv)	WTI with contacts	1 no.
v)	OTI with contacts	1 no.
vi)	Pressure relief device	1 no.
vii)	MOG	1 no.
viii)	Buchholz relay complete	1 no.
ix)	Set of gaskets	1 set
x)	Set of valves	1 set
xi)	Cooler fan with motor	2 nos.



Section- 9 (Mandatory Spares)

xii)	Oil pump with motor	2 nos.
xiii)	Air cell for conservator	1 no.
xiv)	Set of Tap changer contacts	1 set
xv)	Sudden Pressure relay	1 no.
9.4.3.2 Station transformer		
i)	Set of Gaskets	1 set
ii)	Bushing of each type	1 no.
iii)	CT of each type	1 no.
iv)	Cooler fan	1 no.
v)	Oil pump	1 no.
vi)	Pressure relief device/ valve	1 no.
vii)	Oil flow indicator	1 no.
viii)	Buchholz relay	1 no.
ix)	WTI	1 no.
x)	OTI	1 no.
xi)	valves of each type	1 set
xii)	Remote tap position indicator	1 no.
xiii)	RTD complete with WTI	1 no.
xiv)	Fan with Starter	1 no.
xv)	Thermometer	1 no.
xvi)	Breather	1 no.
xvii)	Oil gauge	1 no.
xviii)	Gas collecting device	1 no.
xix)	Air cell (oil preservation equipment)	1 no.
xx)	Flat, Ring, Box spanner set	1 no.
9.4.3.3 Unit auxiliary transformers		
i)	HV Bushing with metal parts and gaskets	3 nos.
ii)	LV bushing with metal parts and gaskets	3 nos.
iii)	WTI with contacts	1 no.
iv)	OTI with contacts	1 no.
v)	Pressure relief device	1 no.
vi)	MOG	1 no.
vii)	Buchholz relay complete	1 no.
viii)	Set of gaskets	1 set
ix)	Set of valves	1 set
x)	Cooler fan with motor	3 nos.
xi)	Air cell for conservator	1 no.
xii)	Set of Tap changer contacts	1 set
xiii)	Sudden Pressure relay	1 no.



9.4.4	11kV and 3.3kV Segregated Phase Busducts		
9.4.4.1	11kV segregated phase busducts		
i)	Bus insulators of each type and rating		3 nos.
ii)	Set of seal-off bushings of each type and rating		3 sets
iii)	Set of 3 phase, Aluminium flexibles		3 sets
iv)	Set of 3 phase, copper flexibles		2 sets
v)	Drain plug with cap		5 nos.
vi)	Silica Gel Breathers		3 nos.
vii)	Gaskets of each type (20 mtrs. Set)		3 sets
viii)	Belleville washers		50 nos.
ix)	Rubber bellows		4 sets
x)	Densal or equivalent compound		1 kg
xi)	Space heaters complete set		2 sets
9.4.4.2	3.3kV segregated phase busducts		
i)	Bus insulators of each type and rating		3 nos.
ii)	Set of seal-off bushings of each type and rating		3 sets
iii)	Set of 3 phase, Aluminium flexibles		3 sets
iv)	Set of 3 phase, copper flexibles		2 sets
v)	Drain plug with cap		5 nos.
vi)	Silica Gel Breathers		3 nos.
vii)	Gaskets of each type (20 mtrs. Set)		3 sets
viii)	Belleville washers		50 nos.
ix)	Rubber bellows		3 sets
x)	Densal or equivalent compound		1 kg
xi)	Space heaters complete set		2 sets
9.4.5	Auxiliary Service Transformers		
9.4.5.1	Oil filled type transformer		
i)	HV, LV and Neutral bushing of each type and rating		1 set
ii)	Winding temperature indicator for each rating of transformer		1 no.
iii)	Tap changer contacts for each rating of transformer		1 set
iv)	Magnetic oil gauge/ oil level indicator with contacts for each rating of transformer		1 no.
v)	Oil temperature indicator with contacts for each rating of transformer		1 no.
vi)	Buchholz Relay for each rating of transformer		1 no.
vii)	Float with contact for Buchholz Relay for each rating of transformer		1 no.
viii)	Set of gaskets (other than that with bushing) for each rating of transformer		1 no.
ix)	Set of valves for each rating of transformer		1 set
x)	Pressure relief device for each rating of transformer		1 no.
xi)	Neutral grounding resistor of each type and rating		1 no.



9.4.5.2	Dry type transformer		
i)	Limb of complete LT and HT of temperature sensing devices		1 set
ii)	Bushing (in case of separate item on transformers offered) HV, LV and LV neutral		3 nos.
iii)	Tap changer contacts		1 set
9.4.6	Motors		
9.4.6.1	11kV motors		
i)	Termination kits (if elastimold type) of each type		2 nos.
ii)	Termination kits (end connection)		10 nos.
iii)	Temperature indicators		5 nos.
iv)	Vibration indicators		5 nos.
v)	Terminal box Teflon glands		10 nos.
vi)	Phase segregated terminal boxes		2 nos.
vii)	Heaters		5 sets
viii)	Couplings		2 nos.
ix)	Bearings (DE and NDE) for each type and rating of motors		3 sets
x)	Motor of each type and rating		One number of each type and rating for both the units
9.4.6.2	3.3kV motors		
i)	Termination kits (if elastimold type) of each type		2 nos.
ii)	Termination kits (end connection)		10 nos.
iii)	Temperature indicators		5 nos.
iv)	Vibration indicators		5 nos.
v)	Terminal box Teflon glands		10 nos.
vi)	Phase segregated terminal boxes		2 nos.
vii)	Heaters		3 sets
viii)	Couplings		2 nos.
ix)	Bearings (DE and NDE) for each type and rating of motors		3 sets
x)	Motor of each type and rating		One number of each type and rating for both the units



9.4.6.3	415V motors	
i)	Terminal plates for motors upto 30kW for each rating	10 nos.
ii)	Terminal plates for motors above 30kW for each rating	5 nos.
iii)	Heaters	2 sets
iv)	Greasing arrangements for each type of motor	4 sets
v)	Motor of each type and rating	10% of the installed quantity or minimum 1 number whichever is higher
vi)	Bearings (DE and NDE) for each type and rating of motor	5 sets
9.4.6.4	DC motors	
i)	Carbon brushes of each type	10 sets
ii)	Brush assemblies of each type	2 sets
iii)	Terminal blocks of each type	2 sets
iv)	Heaters of each type	2 sets
v)	Pulleys of each type	2 sets
vi)	Motor of each type and rating	10% of the installed quantity or minimum 1 number whichever is higher
vii)	Bearings (DE and NDE) for each type and rating of motor	3 sets
9.4.7	11kV and 3.3kV Switchgears	
9.4.7.1	11kV switchgears	
i)	Breaker pole of each rating	1 set
ii)	Spring charging motor complete of each type	5 nos.
iii)	Shunt trip coil of each type	10 nos.
iv)	Closing coil of each type	10 nos.
v)	Current transformer of each type and ratio of each type	3 nos.
vi)	Potential transformer of each type and ratio of each type	1 no.
vii)	Protective relay of each type	1 no.
viii)	Anti-pumping relay of each type and rating	1 no.
ix)	Auxiliary relays of each type	5 nos.
x)	Lock out relays of each type	5 nos.
xi)	Timers of each type	5 nos.
xii)	Moving contact assembly of each installed rating	5 sets
xiii)	Stationary (fixed) contact	5 sets
xiv)	Bus seal-off bushings of each type	2 nos.
xv)	Busbar support insulators	5% of total population



Section- 9 (Mandatory Spares)

xvi)	Limit switches of each type	5 nos.
xvii)	Closing spring of each type	3 nos.
xviii)	Tripping spring of each type	3 nos.
xix)	Control switches of each type	3 nos.
xx)	Selector switches of each type	3 nos.
xxi)	Isolation switch for the control supply of each type	3 nos.
xxii)	Operating mechanism rod for each rating	3 nos.
xxiii)	Set of gaskets of each rating	3 sets
xxiv)	Ammeter of each type and range	1 no.
xxv)	Voltmeter of each type and range	1 no.
xxvi)	Circuit breaker aux. contact assembly of each type and rating	5 nos.
xxvii)	Indicating lamps	50 nos.
xxviii)	Indicating lamp covers of all colours, lamp resistors and holders	10% of installed quantity
xxix)	Fuse base and holder of each type and rating of each type	5 nos.
xxx)	Fuse of each rating of each type of each type	10 nos.
xxxi)	Maintenance tools and accessories for maintenance	3 sets
xxxii)	Carbon brushes for spring charging motor	20 sets
xxxiii)	Isolating contact (Fixed and moving) of each rating	1 set
xxxiv)	Terminal blocks	10 nos.
xxxv)	Arc chute (for each rating)	3 nos.
xxxvi)	SF ₆ cylinders with SF ₆ gas filled alongwith nozzle for filling the gas if applicable	3 nos.
xxxvii)	Bearings for spring charging motor	5 sets
xxxviii)	Multiple pin plug contact assy. with cables (male and female)	5 nos.
xxxix)	Guide for moving contact complete set	5 sets
xl)	Inter-phase barrier for each type	3 nos.
xli)	Pressure gauge (for SF ₆ breaker)	2 nos.
xlii)	Contactors with HRC fuses of each type and rating	10%
xliii)	Auxiliary contactors of each type and rating	10%
xliv)	Control supply transformers of each type	1 no.
xlv)	Breaker Trolley with each panel	1 no.
9.4.7.2 3.3kV switchgears		
i)	Breaker pole of each rating	1 set
ii)	Spring charging motor complete of each type	4 nos.
iii)	Shunt trip coil of each type	10 nos.
iv)	Closing coil of each type	10 nos.
v)	Current transformer of each type and ratio of each type	3 nos.
vi)	Potential transformer of each type and ratio of each type	1 no.
vii)	Protective relay of each type	1 no.
viii)	Anti-pumping relay of each type and rating	1 no.
ix)	Auxiliary relays of each type	5 nos.
x)	Lock out relays of each type	5 nos.



Section- 9 (Mandatory Spares)

xi)	Timers of each type	5 nos.
xii)	Moving contact assembly of each installed rating	3 sets
xiii)	Stationary (fixed) contact	3 sets
xiv)	Bus seal-off bushings of each type	2 nos.
xv)	Busbar support insulators	5% of total population
xvi)	Limit switches of each type	5 nos.
xvii)	Closing spring of each type	3 nos.
xviii)	Tripping spring of each type	3 nos.
xix)	Control switches of each type	3 nos.
xx)	Selector switches of each type	3 nos.
xxi)	Isolation switch for the control supply of each type	3 nos.
xxii)	Operating mechanism rod for each rating	3 nos.
xxiii)	Set of gaskets of each rating	4 sets
xxiv)	Ammeter of each type and range	1 no.
xxv)	Voltmeter of each type and range	1 no.
xxvi)	Circuit breaker auxiliary contact assembly of each type and rating	5 nos.
xxvii)	Indicating lamps	50 nos.
xxviii)	Indicating lamp covers of all colours, lamp resistors and holders	10% of installed quantity
xxix)	Fuse base and holder of each type and rating of each type	5 nos.
xxx)	Fuse of each rating of each type of each type	10 nos.
xxxi)	Maintenance tools and accessories for maintenance	3 sets
xxxii)	Carbon brushes for spring charging motor	20 sets
xxxiii)	Isolating contact (Fixed and moving) of each rating	1 set
xxxiv)	Terminal blocks	10 nos.
xxxv)	Arc chute (for each rating)	3 nos.
xxxvi)	SF ₆ cylinders with SF ₆ gas filled alongwith nozzle for filling the gas if applicable	3 nos.
xxxvii)	Bearings for spring charging motor	5 sets
xxxviii)	Multiple pin plug contact assy. with cables (male and female)	5 nos.
xxxix)	Guide for moving contact complete set	5 sets
xl)	Inter-phase barrier for each type	3 nos.
xli)	Pressure gauge (for SF ₆ breaker)	2 nos.
xl ii)	Contactors with HRC fuses of each type and rating	10%
xl iii)	Auxiliary contactors of each type and rating	10%
xl iv)	Control supply transformers of each type	1 no.
xl v)	Breaker Trolley with each panel	1 no.
9.4.8	415V Switchgear and Non-Segregated Phase Busduct, DC Boards	
9.4.8.1	415V Switchgear, DC boards	
i)	Breaker pole of each rating	5 set
ii)	Spring charging motor complete of each type	10 nos.



Section- 9 (Mandatory Spares)

iii)	Shunt trip coil of each type	20 nos.
iv)	Closing coil of each type	20 nos.
v)	Current transformer of each type and ratio of each type	5 nos.
vi)	Potential transformer of each type and ratio of each type	2 nos.
vii)	Protective relay of each type	2 nos.
viii)	Anti-pumping relay of each type and rating	5 nos.
ix)	Auxiliary relays of each type	5 nos.
x)	Lock out relays of each type	5 nos.
xi)	Timers of each type	5 nos.
xii)	Moving contact assembly of each installed rating	10 sets
xiii)	Stationary (fixed) contact	10 sets
xiv)	Bus seal-off bushings of each type	5 nos.
xv)	Busbar support insulators	5% of total population
xvi)	Limit switches of each type	5 nos.
xvii)	Closing spring of each type	5 nos.
xviii)	Tripping spring of each type	5 nos.
xix)	Control switches of each type	5 nos.
xx)	Selector switches of each type	5 nos.
xxi)	Isolation switch for the control supply of each type	5 nos.
xxii)	Operating mechanism rod for each rating	5 nos.
xxiii)	Set of gaskets of each rating	5 sets
xxiv)	Ammeter of each type and range	5 nos.
xxv)	Voltmeter of each type and range	5 nos.
xxvi)	Circuit breaker aux. contact assembly of each type and rating	5 nos.
xxvii)	Indicating lamps	50 nos.
xxviii)	Indicating lamp covers of all colours, lamp resistors and holders	10% of installed quantity
xxix)	Fuse base and holder of each type and rating of each type	5 nos.
xxx)	Fuse of each rating of each type of each type	10 nos.
xxxi)	Maintenance tools and accessories for maintenance	3 sets
xxxii)	Carbon brushes for spring charging motor	20 sets
xxxiii)	Isolating contact (Fixed and moving) of each rating	1 set
xxxiv)	Terminal blocks	10 nos.
xxxv)	Arc chute (for each rating)	5 nos.
xxxvi)	Bearings for spring charging motor	5 sets
xxxvii)	Multiple pin plug contact assy. with cables (male and female)	5 nos.
xxxviii)	Guide for moving contact complete set	5 sets
xxxix)	Inter-phase barrier for each type	3 nos.
xl)	Contactors with HRC fuses of each type and rating	10%
xli)	Auxiliary contactors of each type and rating	10%
xlii)	Control supply transformers of each type	2 nos.



9.4.8.2	415V non-segregated phase busduct	
i)	Bus insulators of each type and rating	3 nos.
ii)	Set of seal-off bushings of each type and rating	3 sets
iii)	Set of 3 phase, Aluminium flexibles	3 sets
iv)	Set of 3 phase, copper flexibles	2 sets
v)	Silica Gel Breathers	3 nos.
vi)	Gaskets of each type (20 mtrs. Set)	4 sets
vii)	Belleville washers	50 nos.
viii)	Space heaters complete set	2 sets
9.4.9	Power and Control Cables	
i)	11kV grade power cables for each type and size	10% of installed quantity
ii)	3.3kV grade power cables for each type and size	10% of installed quantity
iii)	1.1kV grade power cables for each type and size	10% of installed quantity
iv)	1.1kV grade control cables for each type and size	10% of installed quantity
9.4.10	Battery	
i)	Battery cell	10 nos.
ii)	Cell container of each type	10 nos.
iii)	Level indicator	5 nos.
iv)	Vent plugs	10 nos.
v)	Intercell connector	10 nos.
vi)	Set of nuts, bolts and washer	10 nos.
9.4.11	Battery Chargers	
9.4.11.1	For float cum boost charger of unit batteries	
i)	Electronic Cards of each type and rating (with all components mounted)	1 set
ii)	fuses of each type and rating	4 nos.
iii)	SCR of each type and rating	5 nos.
iv)	Blocking Diode of each type and rating	5 sets
v)	Potentiometer of each type and rating	3 sets
9.4.12	Control, Metering and Protection Panels	
i)	Trip circuit supervision relay	1 set
ii)	Voltmeter of each ranges	1 set
iii)	Ammeter of each ranges	1 set
iv)	MW meter of each ranges	1 set
v)	MVAR meter of each ranges	1 set



Section- 9 (Mandatory Spares)

vi)	MWH Meter of each make and model	1 no.
vii)	Frequency Meter of each make and model	
viii)	MW Transducer of each make and model	1 no.
ix)	MVAR Transducer of each make and model	1 no.
x)	Summation MW Transducer	1 no.
xi)	Summation MVAR Transducer	1 no.
xii)	Synchroscope	1 no.
xiii)	Generator differential protection relay (87G)	1 no.
xiv)	Generator inter-turn fault relay (95G)	1 no.
xv)	100% Generator stator earth fault relay (64G1)	1 no.
xvi)	Generator loss of excitation protection relay (40G)	1 no.
xvii)	Generator back-up impedance protection relay (21G)	1 no.
xviii)	Negative phase sequence relay (46G)	1 no.
xix)	Generator reverse power relay (32G)	1 no.
xx)	Generator low forward power relay (37G)	1 no.
xxi)	Generator rotor earth fault protection relay (64F)	1 no.
xxii)	Generator over-voltage relay (59G)	1 no.
xxiii)	Generator pole slipping relay (98G)	1 no.
xxiv)	Synchro check relay (25)	1 no.
xxv)	Generator under frequency protection relay (81G)	1 no.
xxvi)	Standby stator earth fault protection relay (64G2)	1 no.
xxvii)	Generator overload protection relay (51G)	1 no.
xxviii)	Generator over fluxing relay (99G)	1 no.
xxix)	Voltage balance relay (60G)	2 nos.
xxx)	Generator transformer overall differential protection relay (87OA)	1 no.
xxxi)	Generator transformer back-up overcurrent protection relay (51T)	1 no.
xxxii)	Generator transformer restricted earth fault protection relay (87NT)	1 no.
xxxiii)	Generator transformer over fluxing relay (99T)	1 no.
xxxiv)	Generator transformer neutral over current protection relay (51NT)	1 no.
xxxv)	Generator transformer differential protection relay (87T)	1 no.
xxxvi)	Overhead line connection differential protection relay (87L)	1 no.
xxxvii)	Accidental back energization protection relay	1 no.
xxxviii)	Pole discrepancy protection relay (162)	1 no.
xxxix)	Breaker (HV) back-up protection relay (50Z)	1 no.
xl)	Unit auxiliary transformer (UAT) differential protection relay (87UAT)	1 no.
xli)	UAT restricted earth fault protection relay (87NUAT)	1 no.
xlii)	UAT back-up over current protection relay (51UAT)	1 no.
xliii)	UAT back-up earth fault protection relay (50UAT))	1 no.
xliv)	Auxiliary VT for each type of rating	2 nos.
xliv)	Auxiliary/ intermediate CT for each type of rating	2 nos.



9.4.13	Emergency Diesel Generating Set		
9.4.13.1	Alternator		
i)	Carbon brushes for Generator, and self starter motor		10 sets
ii)	Current Transformers of each rating		1 set
iii)	Instruments of each range		1 set
iv)	Relays of each type		1 set
v)	Timers		1 set
vi)	Indicating light		1 set
vii)	Fuses of each rating		2 sets
viii)	Space heaters with thermostat and isolating switch		1 set
ix)	Cubicle illuminating lights		1 set
x)	Terminal blocks		1 set
9.4.13.2	Diesel engine		
i)	Fuel injection nozzles		2 sets
ii)	Crank shaft with standard size journals		1 no.
iii)	Main bearings		1 set
iv)	Big-end bearings		1 set
v)	Diesel filter packs		20 nos.
vi)	Mobile oil filter packs		20 nos.
vii)	V-belt for radiator fan		5 nos.
viii)	Fuel injector		2 nos.
ix)	Fuel injection piping		1 set
x)	Ring gear for fly wheel		1 no.
xi)	Starter		1 no.
xii)	Nozzle tester, barring bar, slings, eyebolts and other special equipment necessary for servicing the engine		1 set
9.4.13.3	AMF panel		
i)	Protective relay of each type		1 no.
ii)	Auxiliary relay of each type		1 no.
iii)	Timer of each type		2 nos.



9.5 CONTROL AND INSTRUMENTATION (FOR EACH UNIT)

9.5.1 Distributed Digital Control Monitoring & Information System (DDCMIS)

- i) Keyboards/ mouse
 - a) Keyboard 3 nos. of each type.
 - b) Mouse 3 nos. of each type.
- ii) CRT color monitor 10% or 1 no. of each model and size whichever is more.
- iii) Printers and their parts
 - a) Color Inkjet printers 10% of installed quantity or 1 No. whichever is more
 - b) Color laser printer (A4) -do-
 - c) Color laser printer (A3) -do-
 - d) Dot matrix printer -do-
 - e) Ribbon guide rollers for dot matrix printer 10 nos. of each type
 - f) Print head assemblies for dot matrix printer 10% or 3nos. of each type, whichever is more
 - g) Hard disk drive unit of each 3 no. of each type type as offered in main offer complete with disks and other accessories
 - h) Floppy disk drive unit 3 no.
 - i) CD ROM drive unit 3 no.
 - j) CD writer 3 no.
 - k) Magneto optical disk (MOD) drive unit 2 no.
- iv) MMIPIS devices
 - a) Work stations 2 nos. of each type and model.



Section- 9 (Mandatory Spares)

b)	Server for unit LAN (if applicable)	1 no.
c)	Net work components like witch/repeaters/hubs etc.	2 nos. of each type and model.
d)	Other drives/peripheral devices of each type and model no. in MMIPIS like terminal Servers, DAT tape drive etc. (as applicable), which are not covered in above items but are required to make the system complete.	2 nos. of each type and model
v)	Cables and connectors.	
a)	Prefab interconnecting cables with connectors	2 nos. of each type and length, whichever is more.
b)	System bus cable with connectors	-do-
c)	I/O bus cable with connectors for remote I/O units	do-
vi)	a) Power supply modules & power packs for control system	10% or 2 nos. of each type model and rating, whichever is more
b)	Intelligent UPS for workstation, server, PCs	2 no. of each size and rating
vii)	Electronic modules of each type and model for control system including all type of cards like I/O cards, controller cards, CPU module or card, logic cards etc	10% or 2 nos. of each type and model whichever is more
viii)	Bus coupler/ interface hardware.	10% or 2 nos. of each type and model whichever is more.
ix)	Relays	10% or 2 nos. of each type and model whichever is more.
x)	PCs	2 no. of each type & model.
xi)	Batteries used for battery backup of RAMs.	10 % or 2 nos. of each type and model, whichever is more.



- | | |
|--|--|
| xii) Fuses | 100 % of each type and rating. |
| xiii) Cooling fans for power supply and cabinets | 10% or 2 nos. of each type and model whichever is more |

9.5.2 SG Related Sub-Systems

- | | |
|--|---|
| i) Flame monitoring system | |
| a) Complete flame scanner assembly including scanner head assembly, scanner housing & fibre optic cables | 20% or 2 nos., whichever is more |
| b) Flame scanner lens | 50% |
| c) Electronic cards for scanners | 10% or 2 nos. of each type whichever is more. |
| d) Power supply modules | 10% or 2 nos. of each type whichever is more. |
| ii) Coal feeders | |
| a) Calibration motor | 10% or 2 nos. whichever is more. |
| b) Correction motor | 10% or 2 nos. whichever is more. |
| c) Motion monitor | 10% or 2 nos. whichever is more. |
| d) Speed pick-up | 10% or 2 nos. whichever is more. |
| e) Torque switch | 10% or 2 nos. whichever is more. |
| f) Load cell | 10% or 2 nos. whichever is more. |
| g) Electronic cards & power supply cards | 10% or 2 nos. whichever is more. |
| h) Clutch (if applicable) | 10% or 2 nos. whichever is more. |



Section- 9 (Mandatory Spares)

i)	Local indication lamps	200 %
j)	Panel meters	10% or 2 nos. whichever is more.
k)	Limit switch assembly for coal-on-belt, no coal flow, shear pin failure, etc.	10% or 2 nos., whichever is more.
l)	Coupling (eddy current type etc., if applicable)	10% or 2 nos. whichever is more.
iii)	Electromatic safety valves	
	Pressure switches, controller unit, local PB stations and solenoid valves.	10% or 2 nos. of each type whichever is more.
iv)	Furnace temperature probes	
	Thermocouple	2 Nos.
v)	Acoustic pyrometers	
a)	Signal processor and interface modules	20% or 2 nos. of each type and model whichever is more
b)	Sensors and Transceivers	20% or 2 nos. of each type and model which is more.
c)	All electronic cards including power packs	-do-
vi)	Coal bunker level indicating system	
a)	Sensors	20% or 2 nos. of each type whichever is more.
b)	Electronic cards	10% or 2 nos. of each type and model whichever is more.
c)	Panel indicators/ displays for bunker level	10% or 2 nos. of each type whichever is more.
vii)	Separator level monitoring systems	20% or 2 nos. of each type of component whichever is more
viii)	Conductivity type level monitoring system	
a)	Electrodes	50% of population.



- | | | |
|-----|---|---|
| b) | Electronic cards | 20% or 2 nos. of each type and model whichever is more. |
| c) | Lamps/ LEDs of display units | 100% |
| ix) | Electronic remote drum level monitoring system | |
| a) | Electrodes | 50% of population. |
| b) | Electronic cards | 20% or 2 nos. of each type and model whichever is more. |
| c) | Lamps/ LEDs of display units | 100% |
| x) | Mill and air pre heater fire detection system. | |
| a) | Thermocouple | 10% or 2 nos. whichever is more |
| b) | Process actuator switches | 10% or 1 no. whichever is more |
| c) | Electronic cards including power packs | 20% or 2 nos. of each type and model whichever is more |
| xi) | Turbine supervisory system | |
| a) | Power supply assemblies of all types | 10% or 1 no. of each type whichever is more |
| b) | Temperature sensing elements | 10% or 1 no. of each type whichever is more |
| c) | CJC assemblies of all types | 10% or 1 no. of each type whichever is more |
| d) | Local gauges of all types, range, model no. for temperature, pressure, flow, DP, differential expansion and axial shift | 5% or 1 no. of each type whichever is more |
| e) | Process actuated switch devices of all types, range, model no. for pressure, DP, temperature, flow, level, proximity and any other measurement used | 5% or 1 no. of each type whichever is more |
| f) | Electronic cards/PCBs/interface units of all types used in TSS | 10% or 2 nos. of each type, whichever is more |



Section- 9 (Mandatory Spares)

- | | | |
|------|---|---|
| g) | Instrument valves of all types like isolating, 2/3/5 way valve manifolds high pressure reducing, safety relief, back pressure solenoid valves and any other type of instrument valve used | 5% or 1 no. of each type whichever is more |
| h) | Sensors of all types, range, model for vibration, eccentricity, proximity, differential expansion, axial shift and any other turbo supervisory measurement used. | 10% or 1 no. of each type, whichever is more |
| xii) | Boiler feed pump turbine supervisory system | |
| a) | Power supply assemblies of all types | 10% or 1 no. of each type whichever is more |
| b) | Temperature sensing elements | 10% or 1 no. of each type whichever is more |
| c) | CJC assemblies of all types | 10% or 1 no. of each type whichever is more |
| d) | Local gauges of all types, range, model no. for temperature, pressure, flow, DP, differential expansion and axial shift | 5% or 1 no. of each type, whichever is more |
| e) | Process actuated switch devices of all types, range, model no. for pressure, DP, temperature, flow, level, proximity and any other measurement used. | 5% or 1 no. of each type, whichever is more |
| f) | Electronic cards/PCBs of all types used in TSS | 10% or 2 nos. of each type, whichever is more |
| g) | Instrument valves of all types like isolating, 2/3/5 way valve manifolds, pressure reducing, safety relief, back pressure solenoid valves and any other type of instrument valve used. | 5% or 2 nos. of each type, whichever is more |
| h) | Sensors of all types, range model for vibration, eccentricity proximity, differential expansion, axial shift and any other turbo-supervisory measurement used. | 10% or 2 nos. of each type, whichever is more |



9.5.3 Measuring Instruments

- i) Electronic transmitters
 - a) Transmitters of all types, ranges and model no. (for the measurement of Pressure, differential pressure flow, level, etc.) 10% or 2 no. of each type and model, whichever is more
 - b) Electronic cards / PCB's for each type and model and model of transmitters 10% or 5 nos. of each type, whichever is more
- ii) Temperature elements
 - a) RTDs* of each type & length 10% or 2 nos. whichever is more
 - b) Thermocouples of each type like K-type, R-type, metal etc. and length * 10% or 2 nos. whichever is more
 - c) Cold junction compensation boxes of each model 10% or 2 nos. whichever is more
 - d) Thermostatic units for each model of CJC box. 10% or 2 nos. whichever is more
 - e) Thermowell for application like mill outlet temperature and SH/RH/Economiser true gas temp. in boiler 10% or 2 nos. whichever is more

* (With head assembly, terminal block and nipple)
- iii) Local Indicators like temperature, pressure, differential pressure, flow gauges and flow meters etc., 5% or 1 no. of each make, model and type whichever is more (to be divided to various ranges in proportion to main of all make, model, type population)
- iv) Process actuated switch devices Including all types of pressure, differential pressure, flow, temperature, differential temperature, level switch devices 5% or 1 no. of each type and model whichever is more



- v) Indicators/Recorders
- | | | |
|----|---|--|
| a) | Digital Indicators of each model, type & range (including relevant digital indicators of electrical system) | 10% or 2 nos. min. whichever is more |
| b) | Vertical Indicators of each type & model | 5% or 1 no. of each model whichever is more. |
| c) | Recorders for each type and model | 5% or 1 no. whichever is more |
| d) | Consumables for continuous recorders Charts Ink capsules | 25 rolls per recorder/ 25 nos. per recorder/ 20 nos. per recorder / Ink Pads /Pens |
| e) | Consumables for multi point recorders | |
| | • Charts | 5 nos. per recorder |
| | • Ink pads | 5 nos. per recorder |
| | • Print mechanism/ print head assembly | 10% or 5 nos. of each type whichever is more. |
| f) | Level transmitters (displacer type) | |
| | • Electronic cards / PCB's of level transmitters | 5% or 1 no. whichever is more for each type and model. |
| | • Level transmitters. | 5% or 1 no. of each type, displacer length and model whichever is more. |
| g) | PD type flow transmitters | 5% or 1 set of each type and model whichever is more. |

9.5.4 Power Supply System (24 V DC power supply system)

- | | | |
|------|--|---|
| i) | Silicon controlled thyristors, diodes, power transistors | 100% |
| ii) | Capacitors | 2 set |
| iii) | CTs, CVTs, VTs chokes, AC/DC isolators, contactors, timers, relays | 10% or 2 nos. of each type and rating, whichever is more. |
| iv) | Fuses of each types and rating | 300% |



v)	Fuse free circuit breakers	5% or 2 no. of each type and rating, whichever is more
vi)	Battery/ cells	10% or 2 nos. whichever is more
vii)	Electronic modules of all types.	10% or 2 nos. of each type and model, whichever is more
viii)	Indication lamps	200%
ix)	Lamp holders with series resistor, if any.	10% or 5 nos. of each type, whichever is more.
x)	Cooling fans	10% or 2 nos. of each type, whichever is more.
xi)	Digital/analog panel meters/indicators for UPS	5% or 1 no. of each type whichever is more.
xii)	Relays of all types including overload relays	10% or 2 nos. of each type whichever is more.

9.5.5 Process Connection Piping (for impulse piping/tubing, sampling piping/tubing and air supply piping as applicable)

i)	Valves of all types and models	10% or 2 no. of each type, class, size and model whichever is more.
ii)	2 way, 3way, 5way valve manifolds	10% or 2 no. of each type, class, size and model whichever is more.
iii)	Fittings	10% or 2 packet of each type, class, size and model whichever is more.
iv)	Purge meters	10 % of each model or 2 Nos. whichever is more
v)	Filter regulators	10% of each model or 2 Nos. whichever is more



9.5.6 Instrumentation Cable, Internal Wiring and Electrical Field

- | | |
|--------------------------------------|---|
| i) Pre fabricated cable of each type | 10% of installed quantity |
| ii) Pre fabricated cable connector | 10% or 1 no. of each type and model, whichever is more. |
| iii) Other cables | 10 % of each type, pair and size of actual installed quantity |

9.5.7 Electrical Actuators

- | | |
|---|---|
| i) Actuators | 10% or 2 no. of each type, model and rating, whichever is more. |
| ii) Power unit for modulating actuator | 10% or 2 nos. of each type, whichever is more. |
| iii) DC-DC unit/power pack units | 10% or 2 nos. of each type, whichever is more. |
| iv) Electronic cards | 10% or 5 nos. of each type, whichever is more. |
| v) Brake assembly | 10% or 2 nos. of each type, whichever is more. |
| vi) Brake coils | 10% or 2 nos. of each type, whichever is more. |
| vii) Position feed back transmitters | 10% or 2 nos. of each type, whichever is more. |
| viii) Control unit | 10% or 2 nos. of each type, whichever is more. |
| ix) Torque and limit switch assembly of each unit | 10% or 2 nos. of each type, whichever is more. |

9.5.8 PLC Control System

- | | |
|----------------------------|---|
| i) Power supply unit | 10 % or 2 nos. of each type and model, whichever is more. |
| ii) Input/ output modules. | 10 % or 2 nos. of each type and model, whichever is more. |



Section- 9 (Mandatory Spares)

iii)	Central processor unit	10 % or 2 nos. of each type and model, whichever is more.
iv)	Interface units	10 % or 2 nos. of each type and model, whichever is more.
v)	Interconnecting cables	2 run length of each type and size
vi)	Memory units	10 % or 2 nos. of each type and model, whichever is more.
vii)	Work station including all accessories	2 no. of each type
viii)	Push button & control switches.	10% or 2 nos. of each type and model, whichever is more.
ix)	Connectors for pre-fab cable	5 nos. of each type and model.
x)	Cooling fan in PLC system/cabinet	10% or 2 nos. which ever is more
xi)	Indication lamps of all types	100%
xii)	Annunciation facia	20% or 5 Nos. which ever is more
xiii)	Audible devices	10% or 5 nos. of each type whichever is more.
xiv)	Batteries including battery for RAM battery back-up whichever is more.	10% or 2 nos. of each type
xv)	Keyboard	10% or 2 nos. of each type whichever is more.

9.5.9 Steam and Water Analysis System (SWAS)

i)	High pressure reducing elements	2
ii)	Ion exchange column with resin	1
iii)	pH and conductivity cell	1 of each type
iv)	Chemicals and reagents	10 litres/kg of all types
v)	Primary coolers/secondary coolers	1 of each type



- | | | |
|------|--|----------------|
| vi) | Electronic modules of each type for conductivity. pH, silica, dissolved oxygen, hydrazine | 1 of each type |
| vii) | Temp gauges, solenoid valves, pressure gauges, back pressure regulating valves, 3 way grab valves etc. | 2 of each type |

9.5.10 Flue Gas Analyzers

- | | | |
|------|--|--------------------|
| i) | Analyzers spares like transmitter lens & receiver lens, protection windows for transmitters & receivers, integral pressure & temp. sensors, signal processing unit | 1 no. of each type |
| ii) | Light source and detector unit for opacity, Nox, Sox | 1 no of each type |
| iii) | Cooling and purging air blower unit and set of filters | 1 for each type |

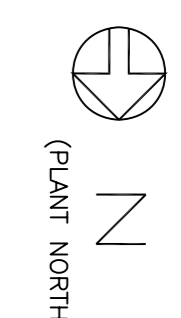
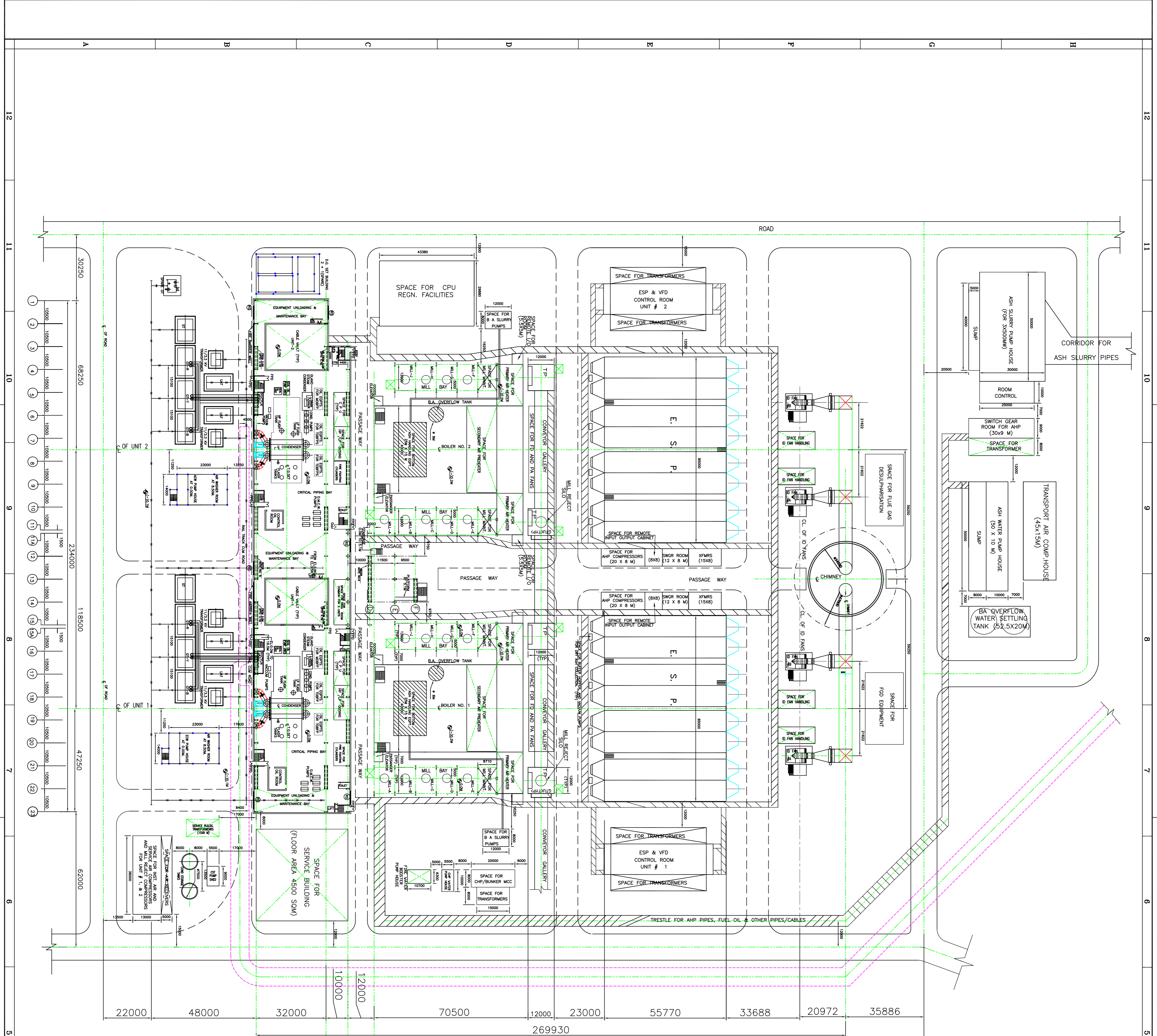

- NOTES**
1. ALL DIMENSIONS ARE IN MM'S AND LEVELS ARE IN METRES.
 2. ALL DIMENSIONS AND ELEVATIONS ARE INDICATIVE ONLY.
 3. NO PIPES, CABLES, STRUCTURES ARE TO BE PLACED BELOW 7.0M (BOP, BOC OR BOS) IN FRONT OF BOILER BETWEEN THE 12.0M CORRIDOR SEPARATING MAIN PLANT AND FIRST ROW OF BOILER COLUMNS. (i.e. CD BAY)
 4. ALL THE DOORS ON C- ROW PROVIDED AT 8.5M & 16.5M. INTERCONNECTING WITH BOILER ARE OF DOUBLE DOOR TYPE TO AVOID INGRESS OF DUST TO MAIN PLANT BUILDING.
 5. LOCATION OF DOORS /REMOVABLE COVERS SHOWN IN THE DRAWINGS ARE INDICATIVE AND SHALL BE FINALISED DURING DETAILED ENGINEERING.

REV/NO	ZONE	DATE	REVISION DESCRIPTION	SN	DATE

PROJECT
CENTRAL ELECTRICITY AUTHORITY
 TYPICAL THERMAL POWER PROJECT
 2 X (500 MW OR ABOVE)
 TITLE
MAIN PLANT LAYOUT PLAN AT EL. 0.0M
 DRG. NO. CEA-TE-STD-A-0001

DESIGN
 DRAWN
 CHECK
 APPR.
 SCALE

PROJECT
 TYPICAL THERMAL POWER PROJECT
 2 X (500 MW OR ABOVE)
 TITLE
 MAIN PLANT LAYOUT PLAN AT EL. 0.0M
 DRG. NO. CEA-TE-STD-A-0001

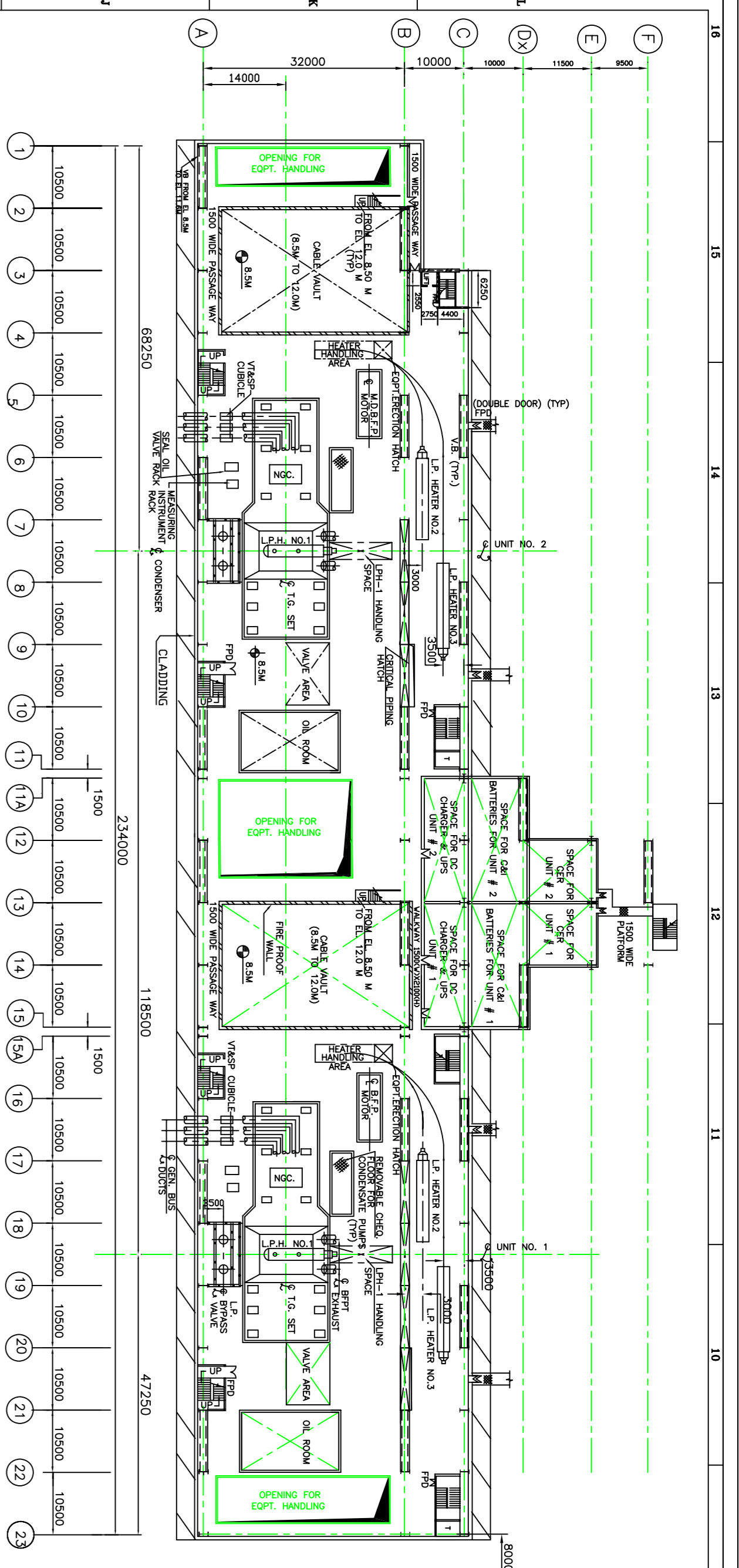

PLAN AT EL. 8.5M

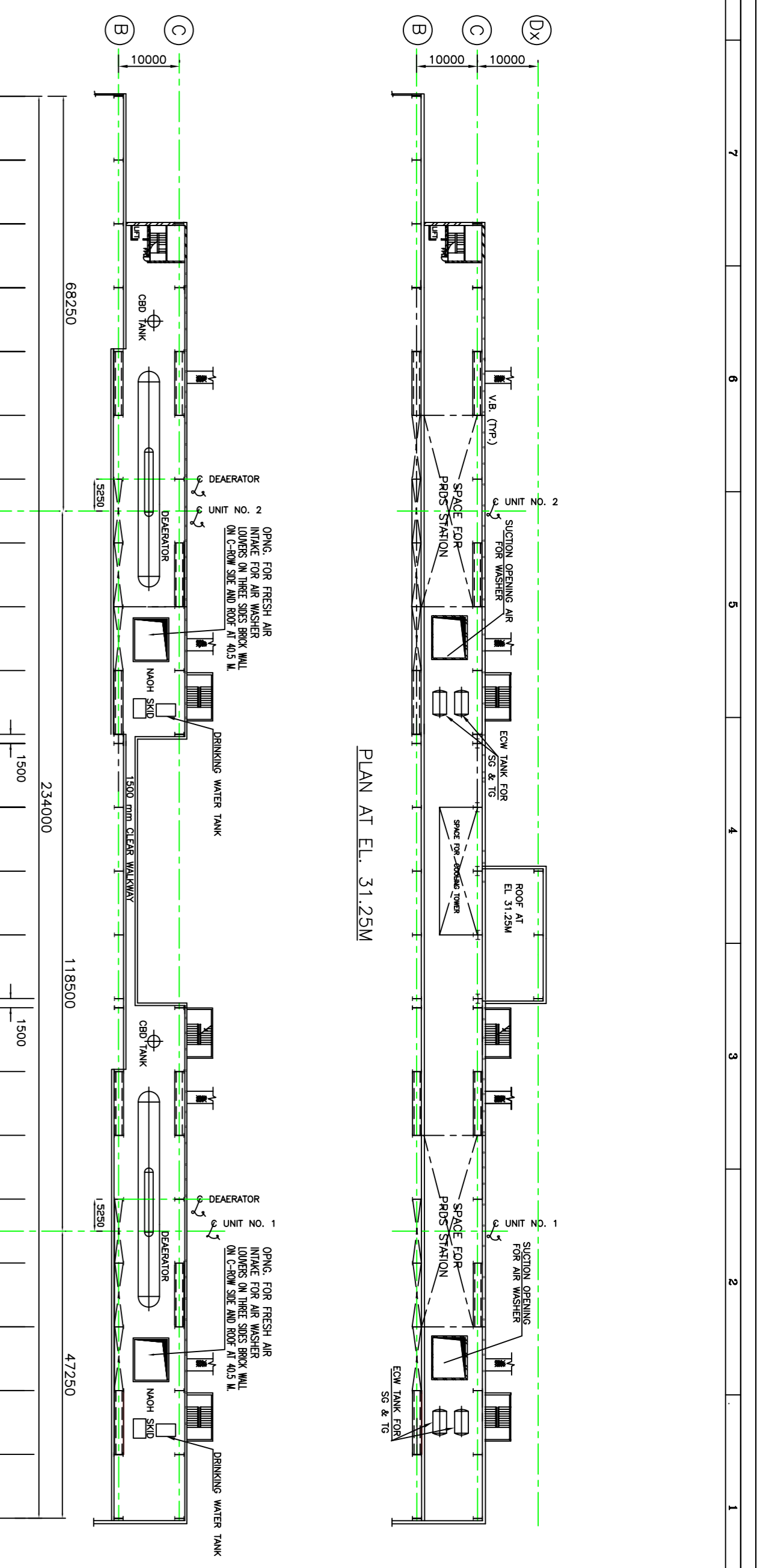

PLAN AT EL. 31.25M

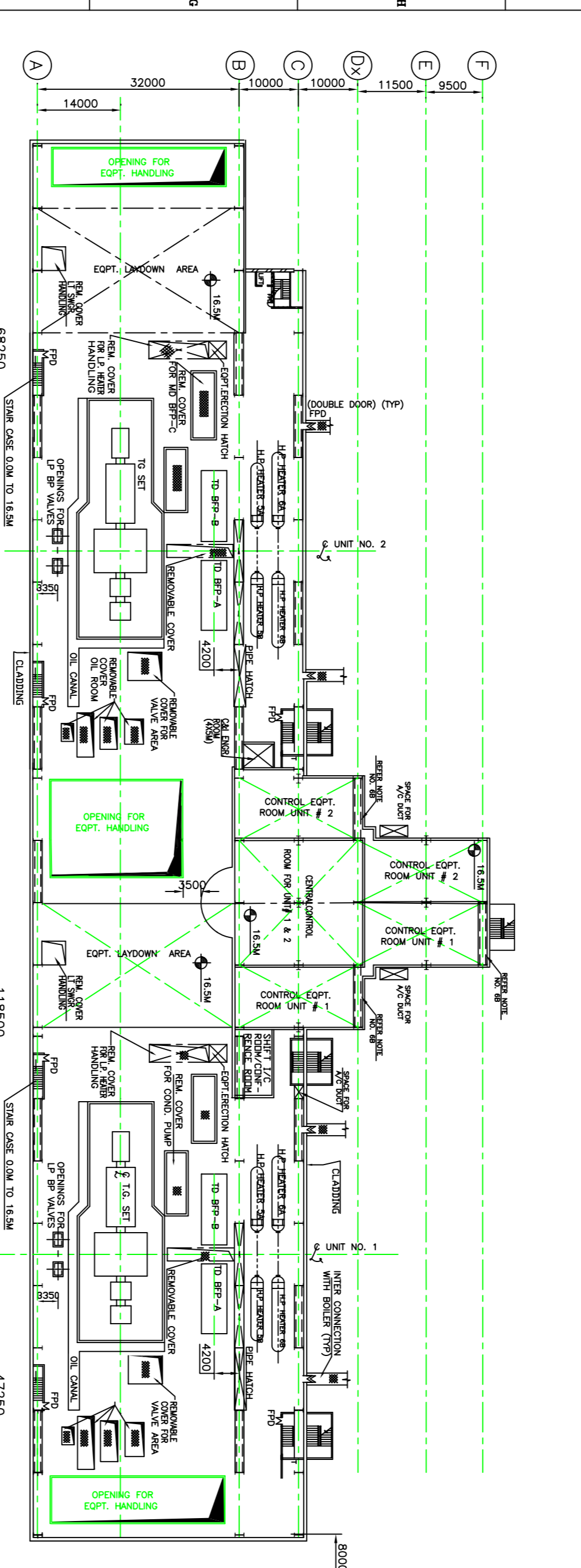

PLAN AT EL. 16.5M

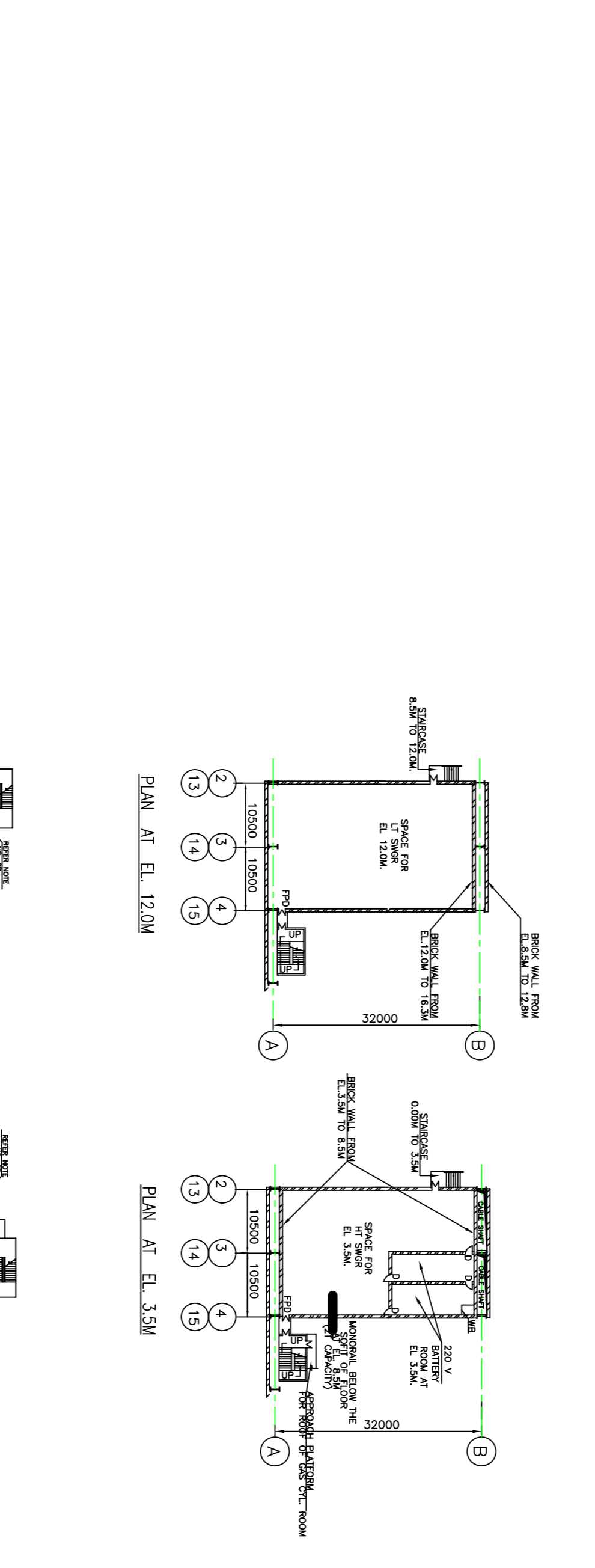
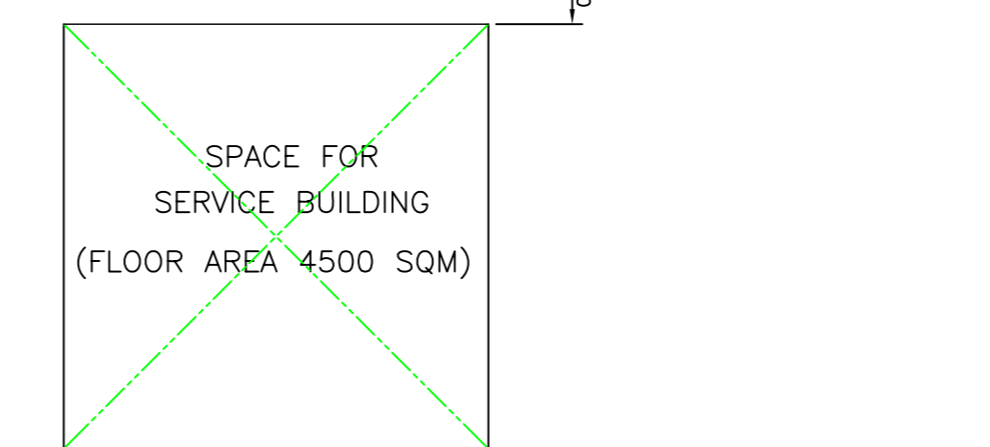

PLAN AT EL. 12.0M

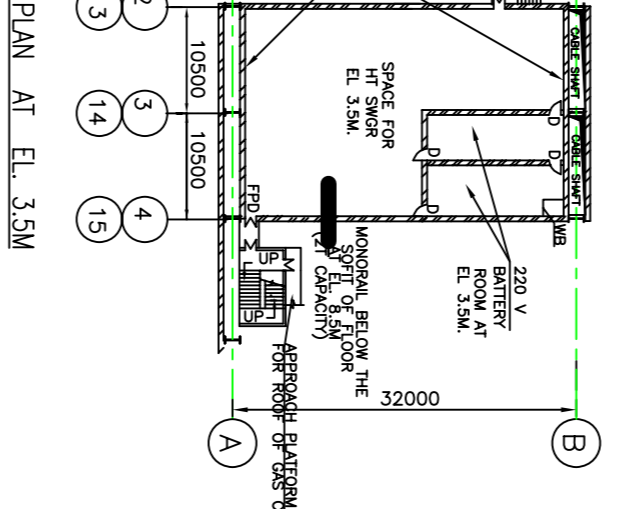

PLAN AT EL. 3.5M

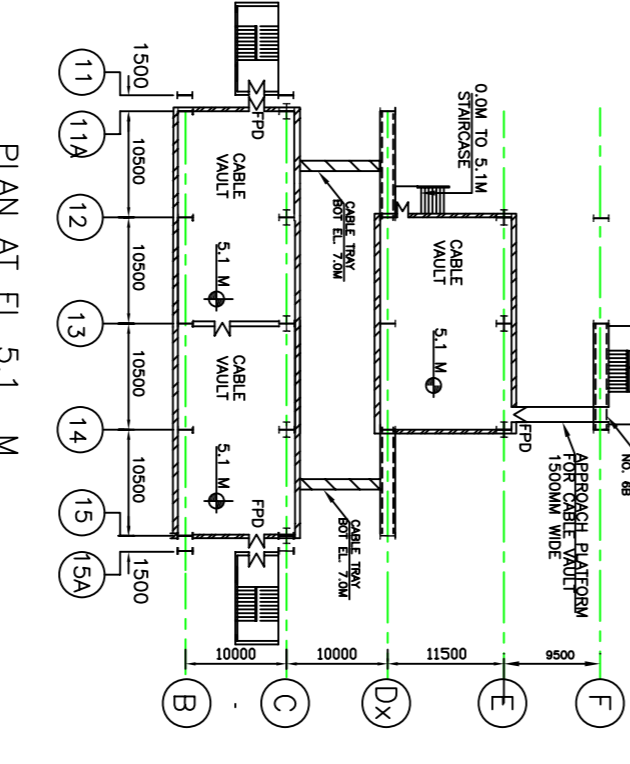

PLAN AT EL. 5.1 M

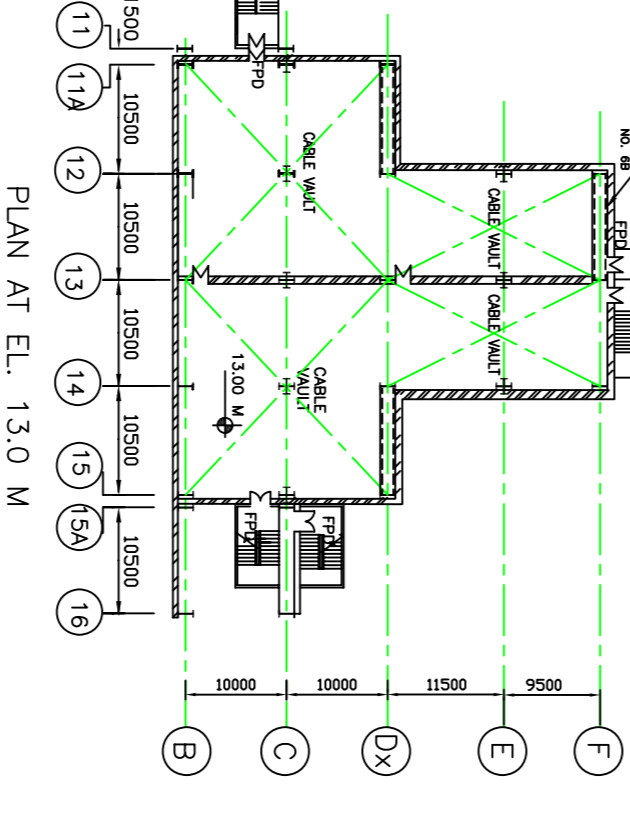

PLAN AT EL. 13.0 M

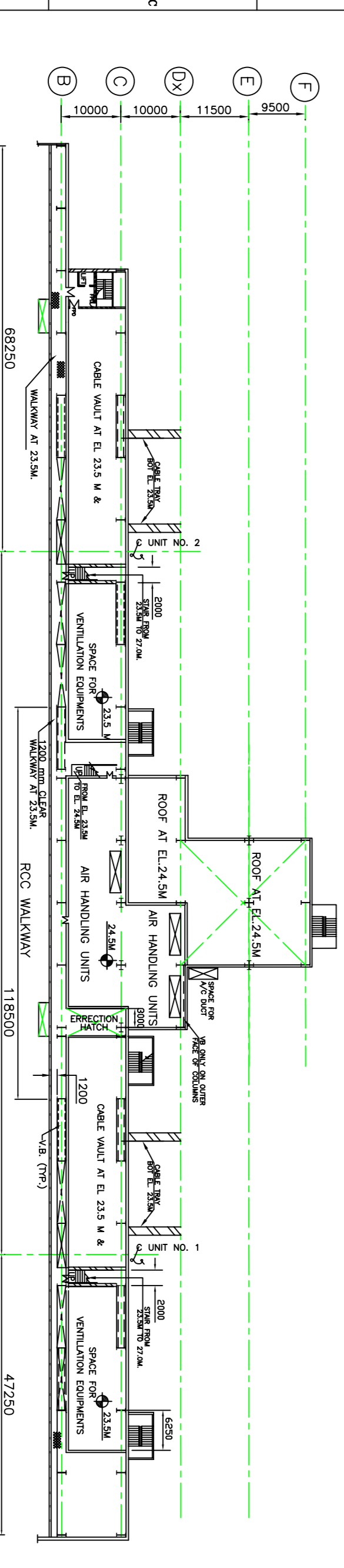

PLAN AT EL. 23.5M/24.5M

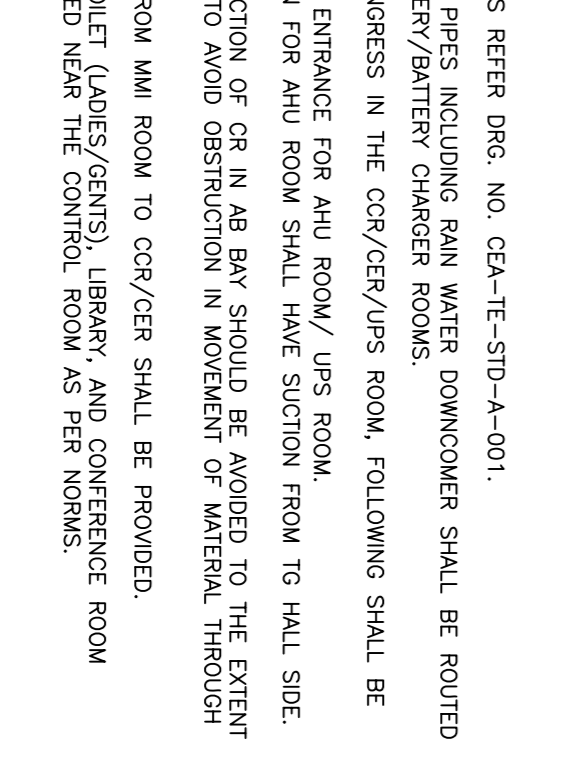

PLAN AT 27.0 M

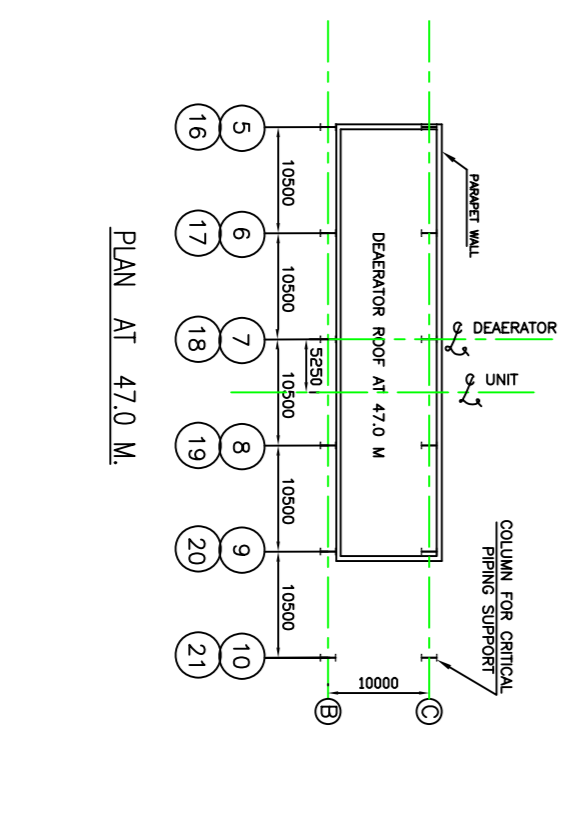

PLAN AT 47.0 M

- NOTES**
- FOR OTHER NOTES REFER DRG. NO. CEA-TE-STD-A-001.
 - NO WATER/STEAM PIPES INCLUDING RAIN WATER DOWNCOMER SHALL BE ROUTED IN COR/CER/BATTERY/BATTERY CHARGER ROOMS.
 - TO AVOID DUST INGRESS IN THE COR/CER/UPS ROOM, FOLLOWING SHALL BE ENSURED:
 - DOUBLE DOOR ENTRANCE FOR AHU ROOM/ UPS ROOM.
 - FRESH AIR FAN FOR AHU ROOM SHALL HAVE SUCTION FROM TO HALL SIDE.
 - EXTENSION/PROJECTION OF CR IN AB BAY SHOULD BE ADDED TO THE EXTENT POSSIBLE SO AS TO AVOID OBSTRUCTION IN MOVEMENT OF MATERIAL THROUGH EOT CRANE.
 - DIRECT ACCESS FROM MMI ROOM TO COR/CER SHALL BE PROVIDED.
 - FACILITIES LIKE TOILET (LADIES/GENTS), LIBRARY, AND CONFERENCE ROOM SHALL BE PROVIDED NEAR THE CONTROL ROOM AS PER IORMS.

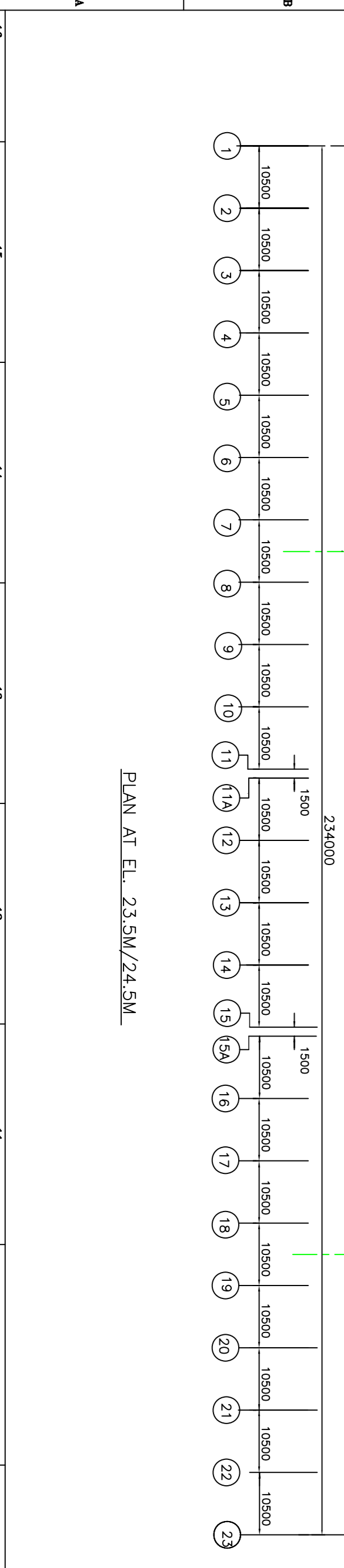

PLAN AT EL. 23.5M/24.5M

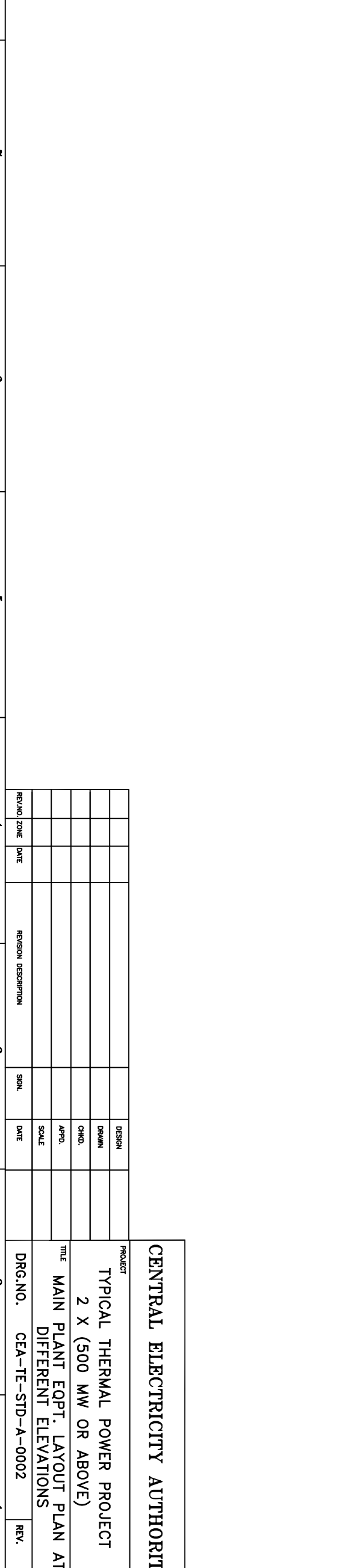

PLAN AT EL. 23.5M/24.5M

NO.	DATE	REVISION	BY	CHECKED

PROJECT: TYPICAL THERMAL POWER PROJECT
 SHEET NO.: 2 X (500 MM OR ABOVE)
 TITLE: MAIN PLANT EOPF LAYOUT PLAN AT DIFFERENT ELEVATIONS
 DRG. NO.: CEA-TE-STD-A-0002

CENTRAL ELECTRICITY AUTHORITY

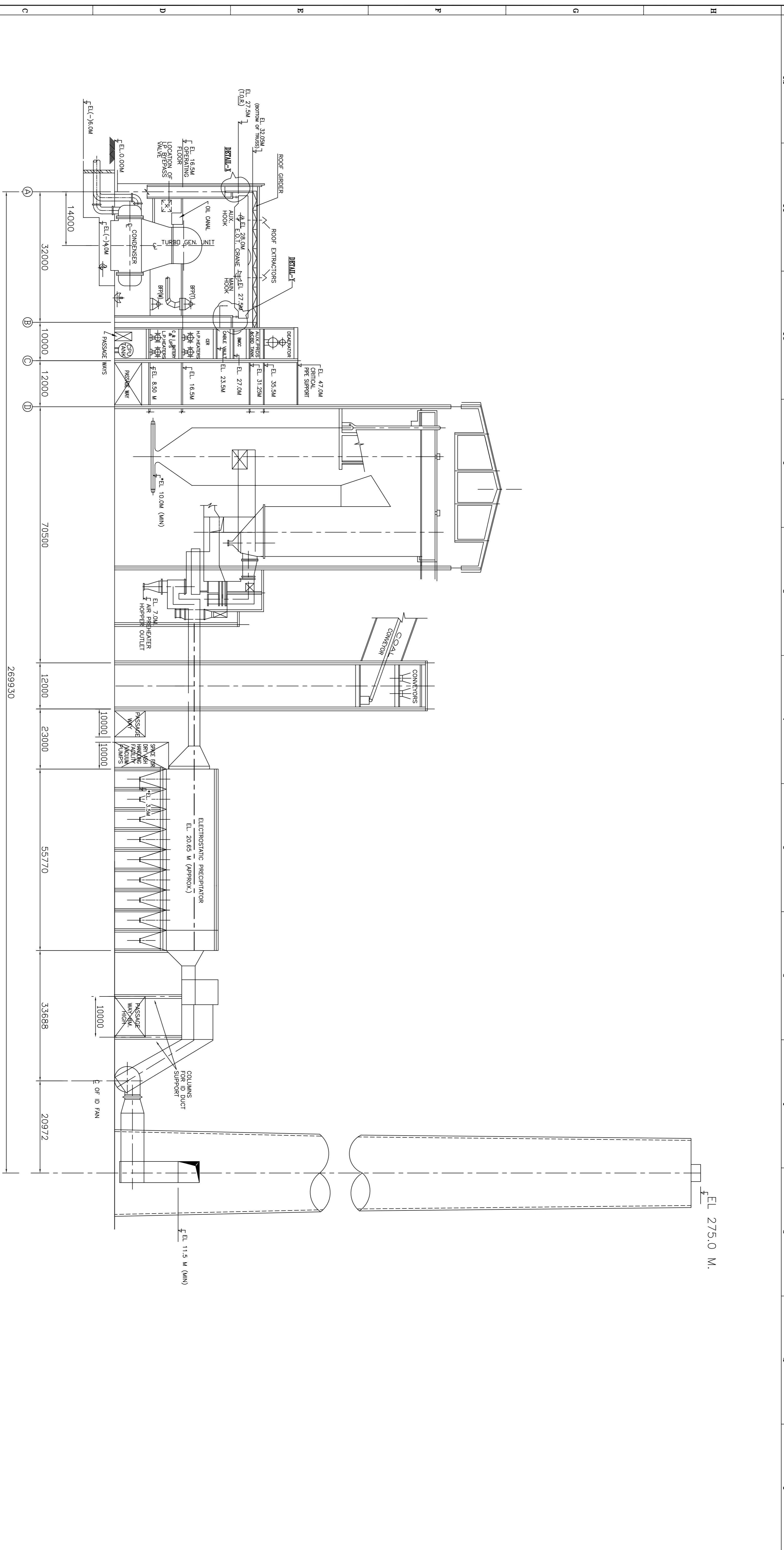

NOTE

1. THE LAYOUT & ARRANGEMENT OF BOILER AND CONDENSOR & THE DIMENSIONS & ELEVATIONS SHOWN HERE ARE INDICATIVE ONLY. HOWEVER THE ELEVATIONS MARKED (*) ARE THE MINIMUM LEVELS & ARE TO BE FOLLOWED BY THE BIDDER.
2. E.O.T. CRANE OPERATOR'S CABIN SHALL BE ON B - ROW SIDE AND D.S.L. FOR THE CRANE SHALL BE ON A- ROW SIDE.
3. FOR OTHER NOTES REFER DRG. NO. CEA-TE-STD-A-001

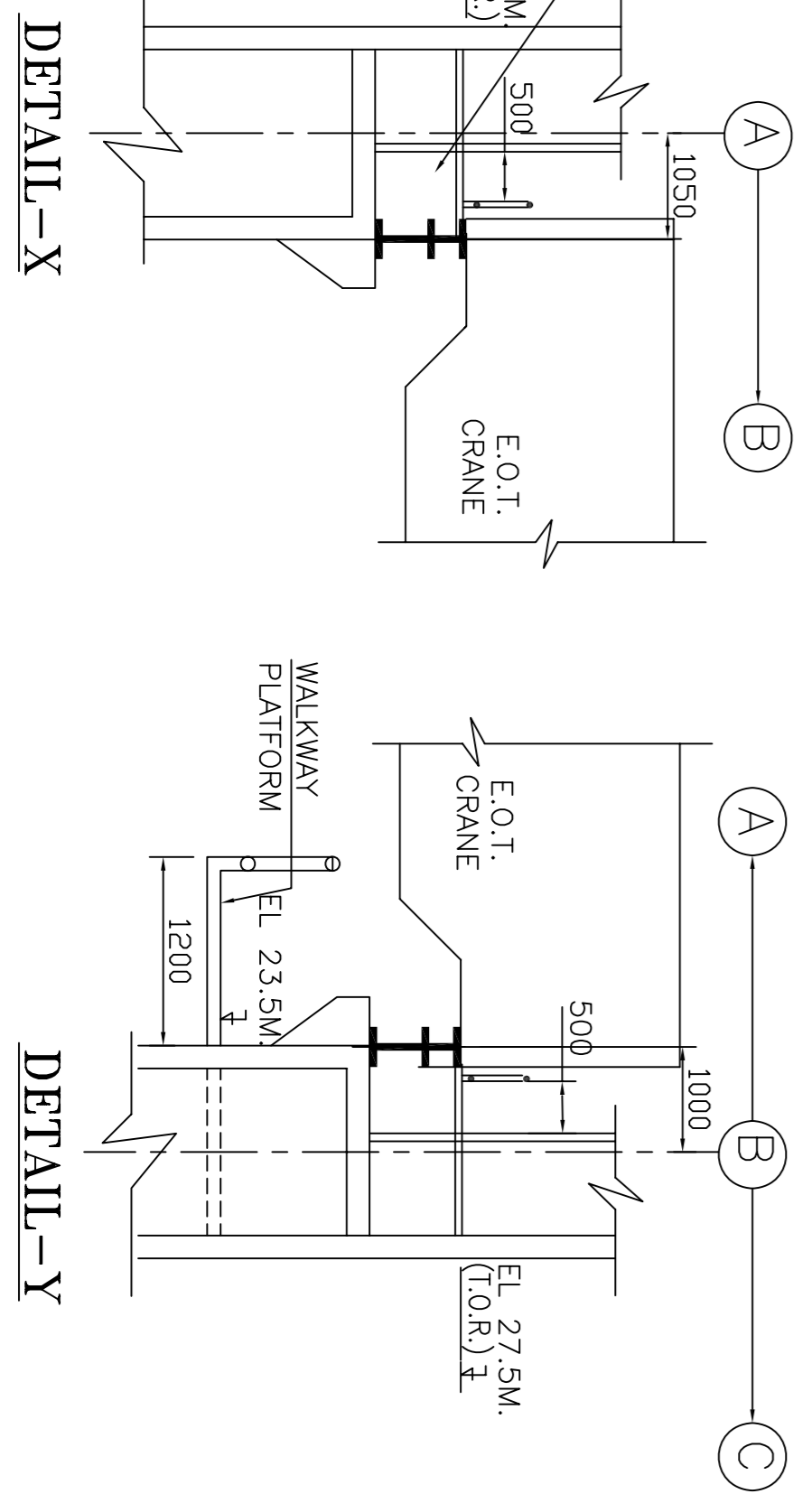

REVISION	DATE	REVISION DESCRIPTION	DESIGN	CHKD.	APPR.	SCALE	DATE

PROJECT		CEA-TE-STD-A-0003
TYPICAL THERMAL POWER PROJECT		
2 X (500 MW OR ABOVE)		
TITLE		MAIN PLANT CROSS SECTION
DRG. NO.	CEA-TE-STD-A-0003	REV.