

Central Electricity Authority
System Planning & Project Appraisal Division
Sewa Bhawan, R.K. Puram, New Delhi – 110066

No. 51/4/SP&PA-2013/202 - 213

Date: 19 February 2013

To

1. The Member Secretary, Southern Regional Power Committee, 29, Race Course Cross Road, Bangalore 560 009. FAX : 080-22259343	2. The Director (Projects), Power Grid Corp. of India Ltd. "Saudamini", Plot No.2, Sector-29, Gurgaon 122 001, Haryana. FAX : 95124-2571932
3. The Director (Transmission), Transmission Corp. of Andhra Pradesh Ltd., Vidyut Soudha, Hyderabad – 500 082. FAX : 040-66665137	4. The Director (Transmission), Karnataka State Power Transmission Corp.Ltd., Cauvery Bhawan, Bangalore 560 009. FAX : 080 -22228367
5. The Member (Transmission), Kerala State Electricity Board, Vidyuthi Bhawanam, Pattom, P.B. No. 1028, Thiruvananthapuram - 695 004. FAX : 0471-2444738	6. Member (Distribution), Tamil Nadu electricity Board (TNEB), 6 th Floor, Eastern Wing, 800 Anna Salai, Chennai - 600002. FAX : 044-28516362
7. The Director (Power), Corporate Office, Block – I, Neyveli Lignite Corp. Ltd., Neyveli, Tamil Nadu – 607 801. FAX : 04142-252650	8. The Superintending Engineer –I, First Floor, Electricity Department, Gingy Salai, Puducherry – 605 001. FAX : 0413-2334277/2331556
9. Director (Projects), National Thermal Power Corp. Ltd. (NTPC), NTPC Bhawan, Core-7, Scope Complex, Lodhi Road, New Delhi-110003. FAX-011-24360912	10. Director (Operations), NPCIL, 12 th Floor, Vikram Sarabhai Bhawan, Anushakti Nagar, Mumbai – 400 094. FAX : 022- 25991258

Sub: 35th meeting of the Standing Committee on Power System Planning of Southern Region
- Minutes of the meeting

Sir,

The 35th meeting of the Standing Committee on Power System Planning of Southern Region was held on 04th January, 2013 (Friday) at POWERGRID office, Gurgaon.

Minutes of the meeting is enclosed. It is also available at CEA's website (www.cea.nic.in).

Yours faithfully,

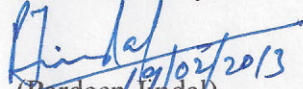
(Pardeep Jindal)

Director (SP&PA)

(Telephone: 011 26198092, Fax No. 011 26102045)

Copy to:

Shri S. K. Soonee, CEO, POSOCO,
B-9, Qutub Institutional Area,
Katwaria Sarai,
New Delhi-110016

GM, SRLDC,
29, Race Course Cross Road,
Bangalore 560 009
FAX – 080-22268725

Central Electricity Authority
System Planning & Project Appraisal Division
Sewa Bhawan, R.K. Puram, New Delhi – 110066

No. 51/4/SP&PA-2013/202 - 213

Date: 19 February 2013

To

1.The Member Secretary, Southern Regional Power Committee, 29, Race Course Cross Road, Bangalore 560 009. FAX : 080-22259343	2.The Director (Projects), Power Grid Corp. of India Ltd. “Saudamini”, Plot No.2, Sector-29, Gurgaon 122 001, Haryana. FAX : 95124-2571932
3.The Director (Transmission), Transmission Corp. of Andhra Pradesh Ltd., Vidyut Soudha, Hyderabad – 500 082. FAX : 040-66665137	4.The Director (Transmission), Karnataka State Power Transmission Corp.Ltd., Cauvery Bhawan, Bangalore 560 009. FAX : 080 -22228367
5.The Member (Transmission), Kerala State Electricity Board, Vidyuthi Bhawanam, Pattom, P.B. No. 1028, Thiruvananthapuram - 695 004. FAX : 0471-2444738	6. Member (Distribution), Tamil Nadu electricity Board (TNEB), 6 th Floor, Eastern Wing, 800 Anna Salai, Chennai - 600002. FAX : 044-28516362
7.The Director (Power), Corporate Office, Block – I, Neyveli Lignite Corp. Ltd., Neyveli , Tamil Nadu – 607 801. FAX : 04142-252650	8.The Superintending Engineer –I, First Floor, Electricity Department, Gingy Salai, Puducherry – 605 001. FAX : 0413-2334277/2331556
9. Director (Projects), National Thermal Power Corp. Ltd. (NTPC), NTPC Bhawan, Core-7, Scope Complex, Lodhi Road, New Delhi-110003. FAX-011-24360912	10. Director (Operations), NPCIL, 12 th Floor, Vikram Sarabhai Bhawan, Anushakti Nagar, Mumbai – 400 094. FAX : 022- 25991258

Sub: 35th meeting of the Standing Committee on Power System Planning of Southern Region
- **Minutes of the meeting**

Sir,

The **35th meeting** of the Standing Committee on Power System Planning of Southern Region was held on **04th January, 2013** (Friday) at POWERGRID office, Gurgaon.

Minutes of the meeting is enclosed. It is also available at CEA's website (www.cea.nic.in).

Yours faithfully,

(Pardeep Jindal)
Director (SP&PA)

(Telephone: 011 26198092, Fax No. 011 26102045)

Copy to:

Shri S. K. Soonee, CEO, POSOCO,
B-9, Qutub Institutional Area,
Katwaria Sarai,
New Delhi-110016

GM, SRLDC,
29, Race Course Cross Road,
Bangalore 560 009
FAX – 080-22268725

**Minutes of the 35th Meeting of the
Standing Committee on Power System Planning in Southern Region (SCPSPSR)
held on 04 January, 2013 (Friday) at POWERGRID office, Gurgaon**

1.0 List of participants is given at Annex-I.

2.0 Member (Power Systems), CEA welcomed the participants and thanked POWERGRID for excellent arrangements for the meeting. He also emphasized the need to purchase power from pit head generations in Eastern Region looking into the load growth in Southern Region. He said that the agenda for today's meeting included some critical issues such as integrated planning for state transmission system, SVC in Southern Region, HVDC connection between Chhattisgarh and Southern Region, etc. He also requested all members of the Standing Committee to furnish their comments/suggestions regarding review of transmission planning criteria. He asked Director(SP&PA), CEA to proceed with the agenda for the meeting.

3.0 Confirmation of the minutes of 34th meeting of the Standing Committee

3.1 Director(SP&PA), CEA stated that minutes of 34th meeting of the Standing Committee on Power System Planning of Southern Region were issued vide CEA's letter No. 51/4/SP&PA-2012/541-552 dated 21st May, 2012. No observations were received on the circulated minutes. Minutes of the 34th meeting, as circulated, were confirmed.

4.0 Transmission System for Evacuation of Wind Power from Andhra Pradesh

4.1 Director(SP&PA), CEA stated that APTRANSCO had informed about proposals to set up the wind projects of about 3150 MW coming up in Uravakonda area (1361 MW), Kondapuram area (1109 MW) and Hindupur area (680 MW) during the period of 2012-17. To identify the transmission system required for wind generation projects, system studies were carried out jointly by CEA, POWERGRID and APTRANSCO during 23-25 April, 2012 in CEA office. Various network configurations were studied to arrive at optimum transmission addition alternatives. Four number of transmission network alternatives were studied to evolve transmission system for evacuation of wind power and transmit it to load centres in Andhra Pradesh. From the study results, as enclosed with the Agenda, the following

alternative was observed as the optimum solution for the integration of wind generation with the Andhra Pradesh grid.

- 1) Uravakonda – Mehboobnagar 400kV quad D/c line
- 2) Kondapur – Kurnool 400kV quad D/c line
- 3) Uravakonda – Kondapur 400kV D/c line
- 4) Uravakonda – Hindupur 400kV D/c line

4.2 Director(GO), APTRANSCO said that as there is more wind potential in that area so lines from Uravakonda to Kondapur and from Uravakonda to Hindupur should be quad so as to optimally utilize the RoW. He also mentioned that looking into the intermittent nature of wind generation there is a need to connect it to ISTS.

4.3 Member(PS), CEA said that presently the proposed connectivity is adequate to transmit and absorb wind power under various wind generation conditions and therefore, connectivity with ISTS is not critical. He emphasized on the need for installation of wind forecasting centers in each cluster by all renewable rich states. He also said that the information from the wind forecasting centres should be communicated to their respective SLDCs and SLDCs should have separate control desk for wind generation. The wind generators should give a day-ahead schedule which may be further revised by them from time to time in real time. Depending upon the wind generation the thermal power plants and storage type hydro plants in states should vary their generation. The impact of intermittent nature of the wind generation should mostly be absorbed within the state system and the impact on ISTS should be minimum.

4.4 After discussion following system was agreed for wind projects of about 3150 MW coming in Uravakonda area (1361 MW), Kondapuram area (1109 MW) and Hindupur area (680 MW) of Andhra Pradesh:

- 1) Uravakonda – Mehboobnagar 400kV quad D/c line
- 2) Kondapur – Kurnool 400kV quad D/c line
- 3) Uravakonda – Kondapur 400kV quad D/c line
- 4) Uravakonda – Hindupur 400kV quad D/c line

4.5 As, these transmission lines may be lightly loaded during the no/low wind months, APTRANSCO also agreed to implement switchable shunt reactors in the scheme to take care of the reactive power. APTRANSCO shall inform CEA and CTU about progress of the agreed transmission scheme, including the planned shunt reactors.

5.0 Connectivity for Nirmal 400kV S/S of APTRANSCO

5.1 Director (SP&PA), CEA stated that APTRANSCO had conducted system studies with various transmission alternatives. Based on their studies they found that connecting the proposed 400kV Nirmal S/S to upcoming 400kV switchyard of Singareni

Collieries (SCCL) Generation Project at Jaipur Mandal, Adiabab would be more feasible solution from APTRANSCO's perspective.

- 5.2 Director(GO), APTRANSCO presented the studies and said that the proposed transmission system for the evacuation of power from Singareni Collieries Generation Project (2x600 MW) includes 400kV D/C(quad) line from generation switchyard to Gajwel and 400kV D/C(twin) line from generation switchyard to Nirmal. With this connectivity of Nirmal S/S, the load of Nirmal area would be fed from SCCL. Further, they are planning to connect upcoming Narsapur S/S with Gajwel. APTRANSCO presented the studies. The study results, which were also later on furnished in CEA, are enclosed at **Annex-II**. He also informed that APTRANSCO has planned a Narsapur 400/220kV S/s with 3x315 MVA transformers and is planned to connect it at 220kV level with Gummdidala, Shapurnagar Extension and Bachupally/Miyapur 220kv S/Ss.
- 5.3 DGM, POWERGRID said that the planned 765kV Hyderabad –Wardha D/C line would be passing through this area. Taking line length into consideration, this line needs to be anchored at some intermediate station.
- 5.4 GM, SRLDC said that the Hyderabad – Kurnool 400kV line always remains overloaded. With HVDC bipole strengthening in Southern Region this link would be relieved. This scheme also includes the New Hyderabad – Kurnool Pooling Station 400kV quad D/C line which is essential for dispersal of power both under import and export scenario as supplement to the planned Hyderabad - Pugalur HVDC Bipole line.
- 5.5 Member(PS), CEA said that in the 30th meeting of the Empowered committee it was decided to review the scheme of HVDC bipole strengthening in Southern Region once again from the point of view of optimization based on latest assessment of the demand generation scenario of SR. He further stated that this link would be beneficial for control of power flow within Southern region and would enable – (i) import of power into SR under deficit scenario, (ii) export in case of surplus, (iii) operate the grid under intermittency of wind generation to meet power requirements of SR constituents and also to decongest the grid.

5.6 After discussions, following was agreed:

- (a) For Nirmal 400kV S/S and Transmission system for Singareni Collieries (SCCL) Generation Project(2x600 MW)**
- (i) Establishment of a 400/220kV Nirmal S/S with 2x315 MVA transformer
 - (ii) Singareni Collieries (SCCL) Generation Project - Nirmal, 400kV D/c line
 - (ii) Singareni Collieries (SCCL) Generation Project - Gajwel, 400kV D/c Quad line

The above system is to be implemented by APTRANSCO.

(b) For Narsapur 400kV S/S and Transmission system for Singareni Collieries (SCCL) Generation Project(2x600 MW)

- (i) Establishment of a 400/220kV Narsapur S/S with 3x315 MVA transformers
- (ii) Gajwel – Narsapur, 400kV D/c line
- (iii) Narsapur to Gummididala, Shapurnagar Extension and Bachupally/Miyapur, 220kV D/C lines

The above system is to be implemented by APTRANSCO.

(c) For Wardha – Hyderabad 765kV D/C line

- (i) The planned Hyderabad –Wardha 765kV D/C line to be anchored at some intermediate station.
- (ii) The location and connectivity at 400kV level of the intermediate station would be decided on the basis of joint studies/visit by CTU, APTRANSCO and CEA.

As the Wardha – Hyderabad line is essential for import of power in Southern Region, CTU to continue with its implementation. Further, **CTU would initiate the studies/visit on priority** to identify location of intermediate S/S and its connectivity with the grid.

(d) For the Hyderabad – Pugalur HVDC System

The Standing Committee felt that in view of the need to transmit power from the northern part of the Southern Region to the southern part of the Southern Region, and to operate the grid under intermittency of wind generation by regulating power flow, the above system as system strengthening scheme is very much essential. The committee requested Member(PS), CEA to again take up the matter with the Empowered Committee. The following system was agreed in the meeting:

- (i) Establishment of a new Hyderabad(HVDC) 400kV GIS S/S with ± 500 kV, 2500 MW capacity HVDC terminal
- (ii) Establishment of a new Pugalur(HVDC) 400kV GIS S/S with ± 500 kV, 2500 MW capacity HVDC terminal
 - * the Hyderabad(HVDC) station to be located near Hyderabad, and the new Pugalur(HVDC) station to be located near Pugalur
- (iii) line from Hyderabad(HVDC) S/S to Pugalur(HVDC) S/S ± 500 kV HVDC bipole line of 2500 MW capacity
- (iv) Hyderabad(HVDC) S/S – Hyderabad (765/400kV PG S/S), 400kV quad 2xD/C lines

- (v) Hyderabad(HVDC) S/S - Kurnool (765/400kV PG S/S), 400kV quad D/C line
- (vi) Pugalur(HVDC) S/S – Udumalpet 400kV, quad D/C line
- (vii) Pugalur(HVDC) – Pugalur 400kV S/S (PGCIL), quad D/C line
- (viii) Pugalur(HVDC) S/S – Tuticorin Pooling Station(PGCIL), 400kV quad D/C line

6.0 Transmission System for evacuation of power from 2x500 MW Neyveli Lignite Corporation Ltd. TS-I (Replacement) (NNTPS) in Neyveli, Tamil Nadu.

6.1 Director(SP&PA), CEA stated that in the joint meeting held on 14-05-2012 at POWERGRID Gurgaon, for evacuation of power from NNTPS (2x500 MW), following system was agreed for connectivity of 2x500 MW Neyveli Lignite Corporation Ltd. TS-I (Replacement) :

Transmission System for Connectivity

- (i) Provision of 7x167 MVA, 400/220 kV transformers at generation switchyard
 - (ii) 1x80 MVAR Bus Reactor at generation switchyard
 - (iii) LILO of existing Neyveli TS-II – Neyveli TS-I Expansion 400 kV S/c at NNTPS generation switchyard
- 6.2 CGM, NLC said that instead of LILO of existing Neyveli TS-II – Neyveli TS-I Expansion 400 kV S/c at NNTPS generation switchyard LILO of TPS-II to Pondy cherry circuit could be considered.
- 6.3 Director(SP&PA), CEA stated that regarding transmission System for LTA ‘NNTPS switchyard – Dharmapuri (new Salem 765/400 kV Substation of POWERGRID) 400 kV D/c line.’ was proposed in joint studies. Also, for system strengthening in Tamil Nadu two options were studied. TNEB vide their letter Dt. 07-06-2012 suggested some modifications.
- 6.4 Director, TANTRANSOCO said that the proposed shifting of feeders MF-I and MF-II from TPS-II to NNTPS 230kV Sw. yd. would lead to spare bays at TPS-II.
- 6.5 The proposed system was put for discussion and **following was agreed** for evacuation of power from 2x500 MW Neyveli Lignite Corporation Ltd. TS-I (Replacement) (NNTPS) in Neyveli, Tamil Nadu:
- 6.6 Transmission System for Connectivity**
- (i) Provision of 7x167 MVA (single phase), 400/220 kV transformers at generation switchyard **(by NLC)**
 - (ii) 1x80 MVAR Bus Reactor at generation switchyard **(by NLC)**
 - (iii) LILO of existing Neyveli TS-II – Pondy cherry 400 kV S/c at NNTPS generation switchyard **(by POWERGRID)**

6.7 **Transmission System for LTA (as an ISTS)**

- (i) NNTPS switchyard – Villupuram (Ginjee) 400kV D/c line
- (ii) Villupuram (Ginjee) 400kV S/S 2x500 MVA

This line shall be an ISTS line.

6.8 **System Strengthening in Tamil Nadu:**

- (i) Establishment of new 230/110kV, 3x160 MVA or 4x100 MVA S/S at Neyveli(TANTRANSCO 230kV S/S) **(by TNEB)**
- (ii) Shifting of the 230kV (3 nos) and 110kV(7 nos) lines owned by TNEB emanating from the existing Neyveli TS-I switchyard to Neyveli 230kV S/S **(by TNEB)**
- (iii) LILO of both circuits of Neyveli TS-I – Neyveli TS-II 230kV D/c line at NNTPS Switchyard **(by NLC)**
- (iv) NNTPS switchyard – Neyveli(TANTRANSCO 230kV S/S), 230kV D/C line with HTLS conductor **(by TNEB)**
- (v) Neyveli TPS-II - Neyveli(TANTRANSCO 230kV S/S), 230kV D/C line **(by TNEB)**

7.0 **Associated transmission system for Kaiga APP St-III(U-5& 6)**

7.1 Director(SP&PA), CEA stated that the issue of power evacuation system from KAPP St -III (2x700 MW) was discussed in the 34th meeting of the Standing wherein, it was observed that due to involvement of the forest area it would be difficult to get a new transmission corridor for building additional transmission lines. As informed by POWERGRID earlier, technically it might be feasible to re-conductor the existing lines i.e. Kaiga – Davangere and Kaiga - Narendra 400kV twin moose D/C line with HTLS conductor. Re-conductoring would take about 24 months per D/C line and shall required to be carried out serially one after the other to avoid complete shutdown of the existing Kaiga APP. Further, even with such arrangement, power from the existing KAPP generations (4x220 MW) shall have to evacuated with reduced reliability of the evacuation system.

7.2 NPCIL informed that the existing switchyard at Kaiga would be upgraded suitably to ensure that main bus/line bays have enough capacity to handle the additional generation of Kaiga- 5& 6. NPCIL enquired about the possibility of re-conductoring one circuit of a D/C line while the other circuit is under operation and also the possibility to compress the time duration of re-conductoring by deploying

more resources. COO(CTU), POWERGRID said that the re-conductoring may take 4 years or more.

7.3 The matter was deliberated and it was agreed that NPCIL would confirm whether they accept operation of existing Kaiga units at reduced reliability of evacuation system (which are also needed for cooling of the core) for the period of re-conductoring which may take about 48 months and after confirmation from NPCIL a joint feasibility studies would be carried out involving CEA, CTU and NPCIL to work out the evacuation system for KAPP St -III (2x700 MW).

8.0 KSEB proposals to avoid congestion in S1-S2 corridor

8.1 Director(SP&PA), CEA stated that KSEB vide their letter dated 15-11-2012 and quoting discussion in the 20th meeting of SRPC has requested to modify the above proposal and instead asked to take up following schemes, connecting Kerala with Karnataka, as a part of regional system strengthening schemes, which shall also relieving the congestion between S1-S2 bid area:

- (i) 400kV D/C Mapusa(Goa) – Kaiga- UPCL - Areacode line and setting up a 400kV, 2x315 MVA S/s at Mylatti (Kasargode) by LILO of one ckt UPCL - Areacode line
- (ii) Construction of 220kV Mylatti(Kerala) – Puttur(Karnataka) D/C line
- (iii) Doubling of 110kV Konaje (Karnataka)- Manjeswaram (Kerala) SC feeder.

8.2 Director(SP&PA), CEA further stated that the above (ii) and (iii) proposals were also discussed in the 34th meeting of the standing committee and KPTCL was asked to examine the proposal and inform CEA so that matter could be taken up for further studies /discussion.

8.3 Director(Transmission), KPTCL said that they do not agree for the construction of 220kV Mylatti – Puttur D/C line and doubling of the 110kV Konaje (Karnataka)- Manjeswaram (Kerala) SC feeder as there is no capacity in their transmission network to supply power beyond Puttur and Konaje.

8.4 Regarding the proposal (i) i.e. ‘400kV D/C Mapusa(Goa) – Kaiga- UPCL - Areacode line’ DGM(CTU), POWERGRID opined that Kaiga being the dense forest area, the route could not be through Kaiga. Further, as Goa and Areacode both are the load centers, this link would not be beneficial to relieve S1-S2 congestion. The possibility of connecting UPCL to Areacode (Kozhikode) could be explored.

8.5 Member(PS), CEA said that the proposed line from Udupi(UPCL) to Areacode is a good proposal to avoid S1-S2 congestion and the Udupi 400kV switchyard is an

- ISTS point. He further said that the Udupi(UPCL) to Areacode line could be built as an ISTS line.
- 8.6 Member(KSEB) also proposed to strengthen the existing Kadakola(Karnataka) – Kaniyampetta(Kerala) 220kV single circuit line into double circuit line. He said that at some locations on this line the sag has become more resulting in reducing the allowable ground clearance. MS(SRPC) said that there are 9 critical locations in Karnataka portion of this line which need to be strengthened by putting additional towers in between. This issue was also discussed in the SRPC meetings, and Karnataka had agreed to strengthen this line. Member(PS), CEA said that Karnataka may strengthen this line at their cost as these line locations are in their portion. The issue was discussed and Director(Transmission), KPTCL agreed for the same.
- 8.7 Regarding the UPCL – Kasargode - Kozhikode link, Member(KSEB) said that northern part of Kerala is facing lot of transmission congestion, as the planned lines i.e. the Mysore-Kozhikode and the Trissur-Kozhikode are getting delayed because of RoW problem.
- 8.8 The matter was deliberated and following scheme was agreed:
Mangalore(Udipi PCL) – Kasargode – Kozhikode 400kV Link
- (i) Mangalore(Udipi PCL) – Kasargode, 400kV quad D/c line
 - (ii) Kasargode – Kozhikode(Areacode), 400kV quad D/C line
 - (iii) Establishment of 2x500 MVA, 400/220kV GIS substation at Kasargode
- (Load flow studies for the above system are given at **Annex-III**.)
- 9.0 Proposal of Electricity Department, Puducherry for erection of 230kV line to Karaikal**
- 9.1 Director(SP&PA), CEA stated that Electricity Department, Puducherry vide their letter dated 25-09-2012 had proposed the erection of 230kV line to Karaikal by LILO of existing 230kV Neyveli- Bahour line to proposed 230kV Auto S/s at Karaikal.
- 9.2 DGM(CTU), POEWERGRID opined that looking into the geographical location of the line, LILOing of the line would not be beneficial. Instead a direct line from Neyveli to Karaikal or from any existing substation of TNEB may also be explored.
- 9.3 NLC suggested that the line may be built from the NLC TS-I switchyard. After deliberations it was decided to implement 230/110kV S/s at Karaikal and a direct 230kV D/c line from NLC TS-I switchyard or any other switchyard/substation in NLC complex to proposed Karaikal S/s as regional system strengthening scheme. CTU to coordinate with Pondicherry, TNEB and NLC agreed to confirm the 230kV

S/s, from where this line may be built. The matter may be taken up in next meeting for finalization.

10.0 Common Transmission System Associated with IPP Projects in Srikakulam Area, Andhra Pradesh

- 10.1 Director(SP&PA), CEA stated that the transmission system for evacuation of power from IPP projects in Srikakulam area was earlier planned to be developed in two phases viz. the 765/400 kV Srikakulam Pooling Station along with Srikakulam – Angul 765 kV D/c line to be initially charged at 400 kV and subsequently upgraded to 765 kV level(covered under Part-A and Part-C of Common Transmission System Associated with IPP Projects in Srikakulam Area). Srikakulam Pooling Station – Vemagiri Pooling Station 765 kV D/c line was approved to facilitate import of power by SR in view of the changed load generation scenario in Southern region. In view of these developments POWERGRID proposed to establish 765 kV level at Srikakulam pooling station right at the beginning and accordingly charge the Srikakulam – Angul 765 kV D/c line also at its rated voltage of 765kV from the beginning itself.
- 10.2 DGM(CTU), POWERGRID said that this would mean taking up Part–A and Part–C of the common transmission system, and suitable deletion of elements meant for initial charging the system at 400kV from the scope of Part – A of the system. POWERGRID also proposed to construct Srikakulam Pooling Station with 400kV portion as AIS and 765kV portion as GIS due to problem in land acquisition.
- 10.3 Members agreed for the above proposal.

11.0 Implementation of Common Transmission System Associated with IPPs in Vemagiri Area, Andhra Pradesh

- 11.1 Director(SP&PA), CEA stated that the common transmission system associated with the IPPs in Vemagiri area, Andhra Pradesh inter-alia comprised of two nos. of 765kV D/c line from Vemagiri to Hyderabad via Khammam planned(to be initially charged at 400kV). Further taking into consideration Srikakulam – Vemagiri 765kV D/c line (planned to facilitate import of power from IPPs in Odisha) it proposed to charge the Vemagiri – Khammam – Hyderabad 765kV D/c line at its rated voltage of 765kV right from the beginning. CEA had conveyed its in-principle approval for charging of Vemagiri – Khammam – Hyderabad 765 kV D/c line at its rated voltage.
- 11.2 Members agreed for the above proposal. Accordingly, following system shall be covered under the scope of above scheme:

- (i) Establishment of 765/400kV GIS Pooling Station at Vemagiri with 3x1500 MVA, 765/400 kV transformers;
- (ii) Establishment of 765/400 kV GIS sub-stations each at Khammam and Hyderabad with 2x1500 MVA, 765/400 kV transformers at each substation;
- (iii) LILO of Gazuwaka-Vijayawada 400kV S/C line at Vemagiri Pooling Station;
- (iv) Hyderabad 765/400kV S/S - Khammam (existing) 400 kV D/C (quad) line;
- (v) Khammam 765/400kV S/S – Khammam (existing) 400kV D/C (quad) line;
- (vi) 2 nos. 765 kV bays each at Vemagiri Pooling Station and Khammam for terminating Vemagiri Pooling Station – Khammam 765kV D/C line being implemented under Tariff Based Competitive Bidding;
- (vii) 2 nos. 765kV bays each at Khammam & Hyderabad for terminating Khammam – Hyderabad 765kV D/C line being implemented under Tariff Based Competitive Bidding.
- (viii) Space provision for 10 nos. 400kV GIS bays at Vemagiri Pooling Station for termination of lines from various IPPs

12.0 220 kV downstream Networks at 400 kV Bidadi, Yelahanka and Cochin Substations.

12.1 Director(SP&PA), CEA stated that POWERGRID is implementing 400/220 kV substations at Bidadi, Yelahanka and Cochin substations under various schemes. The substations are already commissioned from 400kV side, however, 220kV downstream network are yet to be implemented by respective STUs. He further mentioned that POWERGRID is planning augmentation of the transformation capacity at various substations which were approved in earlier standing committee meetings. So POWERGRID had requested STUs to assess the requirement for drawing additional power available at these stations and take up the necessary 220kV network.

12.2 During the discussions it was found that the augmentation of the capacity at various substations was agreed due to overloading of transformers on these substations.

12.3 After deliberations following was agreed:

- (i) STUs i.e. KPTCL and KSEB should expedite the 220kV downstream network at Bidadi, Yelahanka and Cochin substations.
- (ii) No additional bay would be implemented at the substations i.e. Pugalur, Kalivanthapattu, Mysore, Narendra, Trichy, Somnahalli, Warangal,

Hyderabad, Kadappa, Khammam, Gooty, Vijaywada where capacity augmentation was agreed due to overloading on transformers.

13.0 Transmission system for 2x800 MW Krishnapatnam AP TPS

- 13.1 Director(SP&PA), CEA stated that APTRANSCO vide their D.O letter dated 10-09-2102 informed that APGENCO's 1600 MW Krishnapatnam power project will be coming up from June 2013 onwards. APTRANSCO will be completing Krishnapatnam AP- Nellore and Krishnapatnam AP- Chittoor 400kV quad lines by that time. Beyond Chittoor, the Chittoor – Thiruvalam 400kV line is under construction so APTRANSCO requested that Tamil Nadu should complete the down stream 230kV system at Thiruvalam.
- 13.2 Director(TANTRANSCO),TNEB said that they are in process of implementing the 400/220kV S/S at Thiruvalam. The land for the substation has been acquired. He said that TNEB would expedite the work for Thiruvalam S/s and also complete the down stream 230kV system beyond Thiruvalam.

14.0 Unified Real Time Dynamic State Measurement (URTDSM) Project

- 14.1 COO(CTU), POWERGRID stated that the URTDSM project was approved in the Joint Standing Committee Meeting held on 5th March 2012. The scope of the project broadly covers installation of 1739 Phasor Measurement Units (PMU), computer hardware and software at SLDCs/RLDCs/NLDC, installation of OPGW based communication system (10,667 km approx.), development of analytics and consultancy services. In order to encourage indigenization of synchrophasor technology, in the Joint Standing Committee Meeting, it was agreed that 10 to 15% of the PMUs shall be manufactured and supplied from India. POWERGRID opined that 15% of PMU quantity to be manufactured in India may not attract vendors to establish manufacturing facility in India. Therefore, this percentage needs to be enhanced to 30%.
- 14.2 Members agreed to the change.

15.0 Two (2) nos. of 125 MVAR, 400kV Bus Reactors at Vijayawada Substation of POWERGRID.

- 15.1 Director(SP&PA), CEA stated that in the 20th meeting of SRPC held on 28th September, 2012 at Hyderabad 2 nos. of 125 MVAR, 400kV Bus Reactors at Vijayawada substation of POWERGRID has been approved in view of the persistent high voltage profile in the area.

- 15.2 GM, SRLDC added that the Vemagiri, Nagarjuna Sagar and Narendra S/Ss are also facing the high voltage problems. Hence, there is a need to apply one more 125 MVAR bus reactor at each of these substations.
- 15.3 Director, APTRNSCO opined that reactors should be recommended based on the space availability.
- 15.4 After discussions it was decided that 125 MVAR reactors each would be implemented at the Vemagiri, Nagarjuna Sagar and Narendra S/S subject to availability of space at these substations.

16.0 Review of Transmission Planning Criteria

- 16.1 Director(SP&PA), CEA stated that the Enquiry Committee headed by Chairperson, CEA for grid events in July 2012 has recommended that transmission planning criteria needs to be reviewed in the context of market scenario within three months. Members of the Standing Committee on Power System Planning of Southern Region are requested to furnish their comments/ suggestions regarding review of transmission planning criteria to the undersigned along with a soft-copy mailed to *cea.sppa@yahoo.in*.
- 16.2 Member(PS), CEA said that comments from some utilities have been received and a draft would soon be ready. He asked all the members i.e. the STUs and also NTPC and NLC to give their views/observations in regard to review of Transmission Planning Criteria. Members agreed for the same.

17.0 Integrated planning for State transmission system:

- 17.1 Director(SP&PA), CEA stated that the transmission network should be planned in an integrated manner. There have been a few instances in the past where, the STU has planned important transmission system or allowed connectivity to large generation capacities without involving CEA and CTU and this may result in congestion/operational difficulties for the ISTS/national grid. To start with, it is proposed that STU should evolve following of their systems involving CEA and CTU, which would subsequently be firmed up through the Standing Committee forum:-
- (a) 220kV and above system
 - (b) Large scale harnessing of renewable generation
 - (c) System for evacuation of power from a complex having generation capacity of 250 MW and above in case of conventional and 50 MW and above in case of renewable.

17.2 Member(PS), CEA stated that for the integrated planning of the transmission system it is necessary to exchange the data between STUs and CTU. So, it was decided that a forum of transmission planners would be formed involving CEA, CTU and STUs for exchanging and updating the data.

17.3 The STUs agreed to provide the above (as under 17.1) information to CEA and CTU.

18.0 State-wise assessment of the Load Generation Scenario of Southern region.

18.1 Director(SP&PA), CEA stated that for the assessment of load generation scenario, all STUs of Southern Region are requested to provide the seasonal load and generation data in the format given in the agenda for the meeting.

18.2 STUs agreed to provide the load and generation data to CEA and CTU in the format as **given at Annex-IV.**

19.0 Proposal for Dynamic VAR Compensators in Southern Region.

19.1 CE(SP&PA), CEA said that the enquiry committee on grid disturbances recommended that *“In order to avoid frequent outages / opening of lines under over voltages and also providing voltage support under steady state and dynamic conditions, installation of adequate static and dynamic reactive power compensators should be planned”*. So studies have been carried out for dynamic reactive power compensators on All India basis and installation of SVC of +400/-400 MVAR at three locations in Southern Region i.e. Hyderabad, Udumalpet and Trichy substations has been proposed to improve reliability & security of the grid operation.

19.2 POWERGRID presented the studies. GM, SRLDC opined that some more locations may be considered for installation of SVCs on the basis of the proximity of the huge load centers.

19.3 After deliberations, members agreed for the installation of SVC/STACOM of +400/-400 MVAR at three locations in Southern Region i.e. Hyderabad, Udumalpet and Trichy S/S of POWERGRID. It was agreed that studies would also be carried out to explore additional requirement compensation in SR. It was also agreed that pros/cons of SVC v/s STATCOM would be evaluated through relevant studies for technology selection.

20.0 Transmission System Associated with Vallur TPS.

20.1 Director (SP&PA), CEA informed that the transmission system associated with Vallur TPS (earlier Chennai NTPC-TNEB JV TPS - 1000 MW) was discussed &

agreed in two phases. The first phase was discussed & agreed in 22nd, 23rd & 24th Standing Committee meetings. Further a supplementary scheme was also evolved due to increased capacity of Vallur TPS to 3x500 MW and the same was discussed & agreed in the 27th Standing Committee meeting. Accordingly POWERGRID has gone ahead for implementation of the approved transmission system in two phases.

- 20.2 However during the hearing on the Tariff Petition in Hon'ble CERC of the Phase-I transmission system TANTRANSCO had raised some issues due to lack of clarity in the noting of the minutes. Therefore the following may be regularised as below to give clarity to the subject schemes.

Transmission System associated with Vallur TPS (2x500 MW units)

- a) LILO of both circuits of Alamathy – Sriperumbudur 400 kV D/c line at Vallur TPS.

(This has been completed and commissioned in July, 2011.)

Supplementary Transmission System for Vallur TPS (3rd 500 MW unit)

- a) Vallur TPS – Alamathy 400 kV D/c line

(Retaining one 400 kV D/c line of original Vallur TPS transmission system from LILO point to Alamathy by suitably utilizing the LILO of Nellore – Sriperumbudur 400 kV D/c line at Alamathy).

- b) Vallur TPS – Melakottaiyur

(Extending second 400 kV D/c of original Vallur TPS transmission system from LILO point to Melakottaiyur by suitably utilizing part of the LILO of Kolar-Sriperumbudur line at Melakottaiyur. As regards remaining part of the LILO of Kolar-Sriperumbudur line at Melakottaiyur is concerned the same shall be put to use to the extent possible).

- c) Tiruvalam – Chittoor 400 kV Quad line.

With the above arrangement, the Nellore – Sriperumbudur 400 kV D/c and the Kolar-Sriperumbudur 400 kV S/c lines connectivity would be restored.

- 20.3 Further DGM (CTU) informed that POWERGRID is implementing Supplementary Transmission System for Vallur TPS (3rd 500 MW unit) which includes suitably utilizing the LILO of Nellore – Sriperumbudur 400 kV D/c line at Alamathy for Vallur TPS – Melakottaiyur 400kV D/c line. In this regard one LILO line from Alamathy is to be extended to Melakottaiyur & other LILO line to Tiruvalam by TANTRANSCO as part of Transmission System with North Chennai (2x600 MW) generation and restoring the LILO of Nellore – Sriperumbudur 400kV D/c line, the original scheme & proposed system are as given below:

Transmission System associated with Vallur TPS (2x500 MW units)

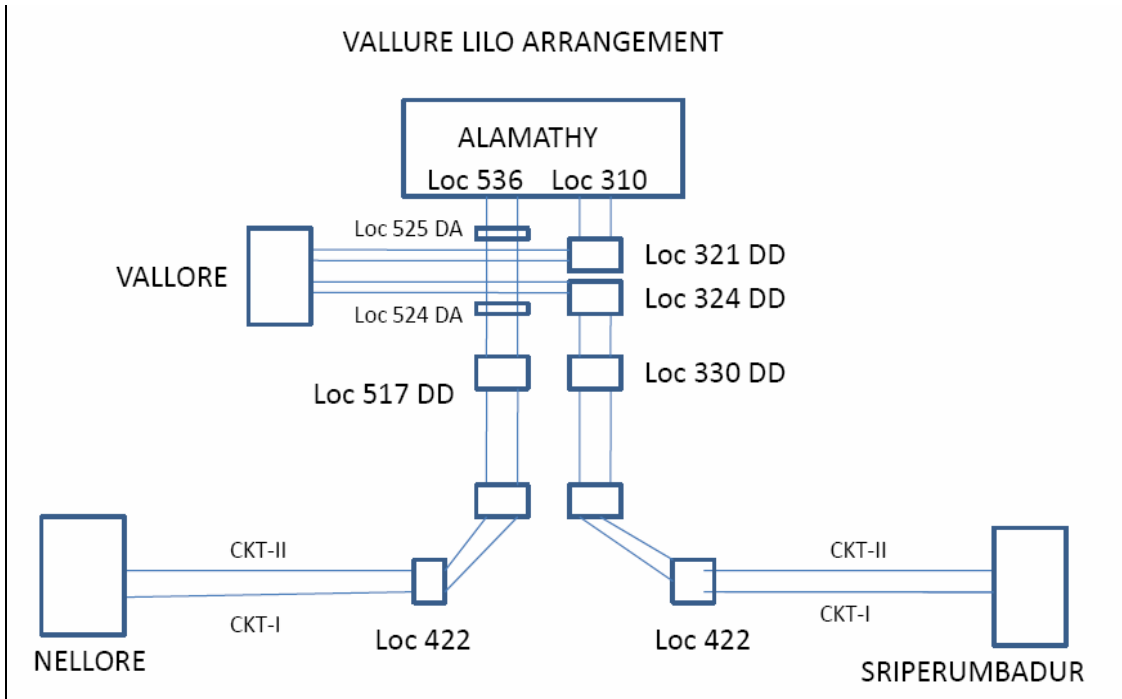

Supplementary Transmission System for Vallur TPS (3rd 500 MW unit) & Transmission System for North Chennai (2x600 MW)

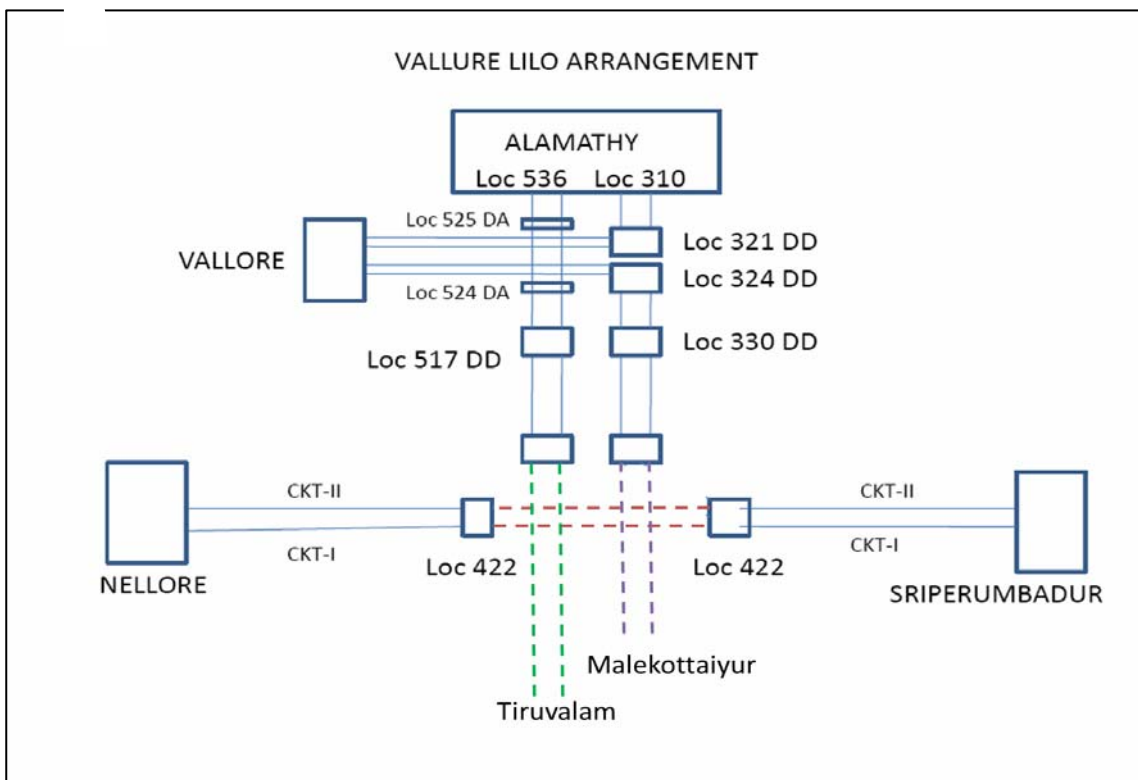

20.4 DGM (CTU) further informed that the Supplementary Transmission System for Vallur TPS is close to commissioning, however TANTRANSCO is yet to acquire the land for Tiruvalam 400/220kV substation and therefore the other LILO line from Alamanthy cannot be extended to Tiruvalam. In view of this POWERGRID proposed that one LILO of Nellore – Sriperumbudur 400 kV D/c line may be restored at this time to extend to the Melakottaiyur and other LILO shall remain which may be extended at later date when TANTRANSCO is ready with the line upto Tiruvalam, the details are as below. With this arrangement the transmission system is utilized with Supplementary Transmission System for Vallur TPS.

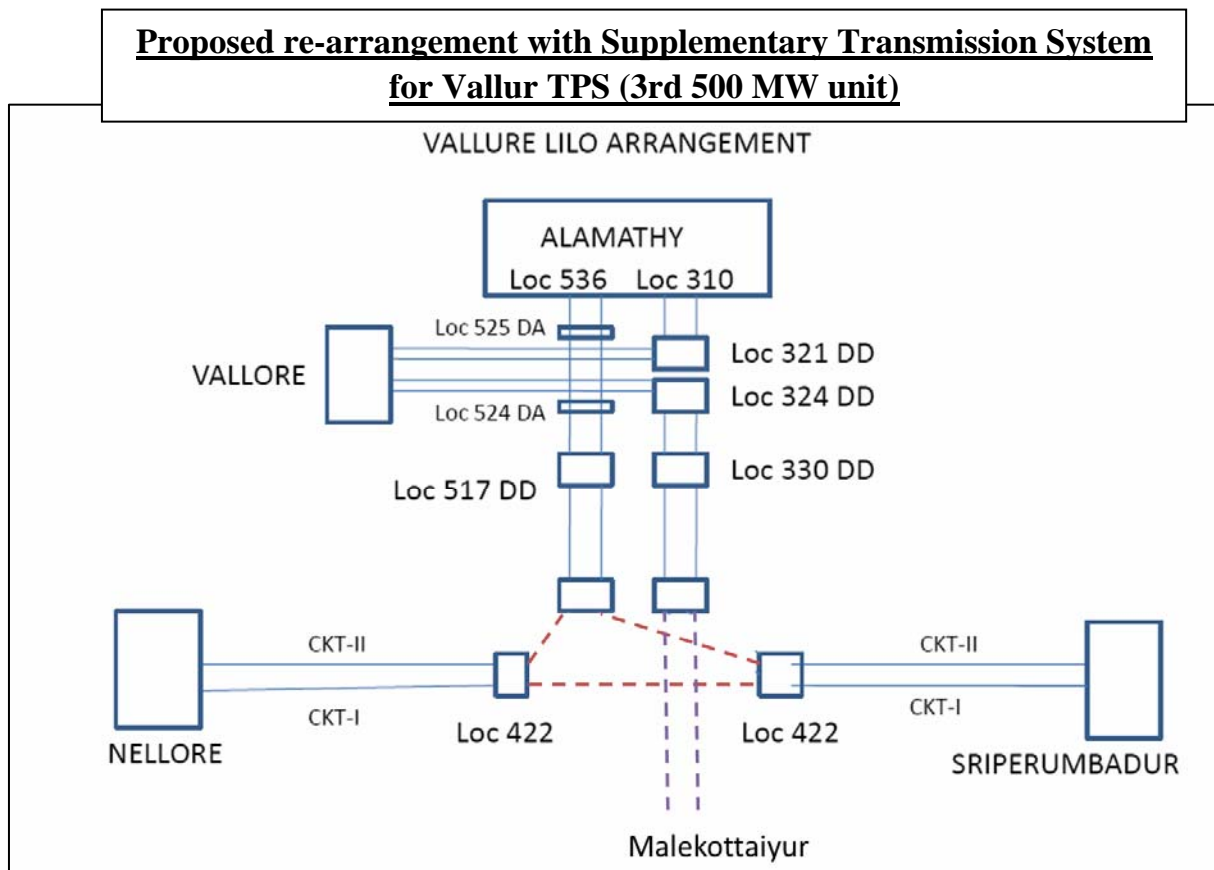

20.5 Members noted the same.

21.0 Transmission system associated with New IPP projects in Chhattisgarh- Shifting of converter terminal associated with ± 600 kV 4000 MW , Raigarh (Kotra) – Dhule HVDC line from Dhule in Western Region to a suitable location in Southern Region.

- 21.1 Director(SP&PA), CEA stated that the transmission system associated with IPPs coming up in Raigarh and Champa generation complex in Chattishgarh was discussed and finalized in the 29th and 30th SCM of WR. The transmission system associated with new IPPs in Chattishgarh inter alia involves \pm 600 kV 4000 MW HVDC bipole from Raigarh pooling station (near Kotra) to Dhule (PG) along with metallic return conductor. In the the 35th meeting of the Standing Committee on Power system Planning of Western Region (held on 3rd Jan, 2013) the WR constituents agreed to shift the converter station from Dhule (PG) in Western Region to some suitable location in Southern Region, hence SR constituent might take this opportunity to have additional power into SR.
- 21.2 Member(PS), CEA said that. as Chhattisgarh IPPs had not indicated any firm beneficiaries for power generated from their plants and therefore, the surplus power can be transferred to Southern Region for meeting its growing demand. This link would also strengthen its inter-connection with rest of all India grid.
- 21.3 Members of the Standing Committee found that it would be better to put the converter station in Tamil Nadu. Director, TANTRANSOCO said that Kanchipuram could be the location for this HVDC terminal Station.
- 21.4 The matter was deliberated and it was decided that the system studies would be carried out jointly by CEA, CTU and TNEB for evolving the transmission system for the proposed HDVC line.

22.0 Modification to the under implementation System Strengthening in Southern region –XII and XII Schemes

- 22.1 Director (SP&PA), CEA stated that two regional strengthening schemes are under implementation by POWERGRID and asked POWERGRID to explain the issue in the implementation of these strengthening schemes

System Strengthening in Southern region – XII

- a) LILO of both circuits of Neelamangla – Hoody 400 kV D/c line at Yelahanka
- b) Establishment of new 400/220 kV GIS substation at Yelahanka

System Strengthening in Southern region – XIII

- a) Gooty – Madhugiri 400 kV D/c line
- b) Madhugiri – Yelahanka Quad 400 kV D/c line

- 22.2 DGM (CTU) explained that under the above two strengthening schemes, 3 nos of 400 kV D/c lines are to be terminated at Yelahanka substation; 2 nos of 400 kV D/c lines for LILO and 1 no 400 kV D/c line for Madhugiri – Yelahanka link. However, Yelahanka substation being in a Metro city of Bengaluru is having a lot of Right-of-Way (ROW) constraints and all three 400kV D/c lines approaching from more or

less same side at Yelahanka. Due to lot of urbanised growth in & around Yelahanka, POWERGRID site has reported that it would be practically impossible to secure as many numbers of ROWs. Towards this it was proposed that only one ROW using the Multi Circuit tower (for about 7-8 km length) supporting one D/c for LILO & one D/c from Madhugiri may be used in view of the severe ROW constraints. Under such an arrangement instead of LILO of both the circuits only one circuit of Neelamangla – Hoody 400 kV D/c line may be made at Yelahanka. The Load flow studies pertaining to modification from LILO of both circuits to one circuit are carried out, wherein it is observed that such arrangement shall lead to only re-distribution of the flows within the ring main without affecting overall security & reliability of the ring.

22.3 DGM (CTU) further stated that as multi circuit towers with all the 4 circuits with twin conductors is already erected therefore in this small Multi Circuit portion, instead of Quad conductor for the Mudhugiri – Yelahanka 400kV D/c Quad line, a high ampacity conductor is proposed to be used as the system is required on the urgent basis to alleviate present constraints.

22.4 After deliberations the following system was agreed

System Strengthening in Southern region – XII

- a) LILO of one circuit on multi-circuit tower in Bengaluru area of Neelamangla – Hoody 400 kV D/c line at Yelahanka (instead of earlier envisaged LILO of both circuits)
- b) Establishment of new 400/220 kV GIS substation at Yelahanka

System Strengthening in Southern region – XIII

- a) Gooty – Madhugiri 400 kV D/c line
- b) Madhugiri – Yelahanka 400 kV Quad D/c line with a small portion to be strung on multi-circuit tower of the SRSR-XII sceme with high ampacity conductor in Bengaluru area

23.0 Implementation of 2nd Raichur – Kurnool 765kV S/c line

23.1 Director (SP&PA), CEA stated that Raichur – Sholapur 765kV S/c line-1 is being implemented through private sector participation for synchronous inter-connection between SR & WR and Raichur – Sholapur 765kV S/c line-2 is being implemented by POWERGRID as part of Transmission System associated with Krishnapatnam UMPP – Part-B. Since Krishnapatnam UMPP, Kudankulam APP, Neyveli TS-II Expn, Tuticorin etc. generation projects in Southern Region are getting delayed, these lines shall be utilised for import of power to SR from other neighbouring surplus regions.

- 23.2 For dispersal of power beyond Raichur substation adequate transmission system is required to meet the load demands. Towards this POWERGRID is already implementing Raichur – Kurnool 765kV S/c line & Kurnool – Nellore Pooling Station 765kV D/c line as part Common Transmission system associated with ISGS projects of Krishnapatnam area in Andhra Pradesh.
- 23.3 Further to facilitate power transfer beyond Kurnool, Kurnool – Thiruvallur 765kV D/c line & establishment of Thiruvallur 765/400kV substation was planned and entrusted to POWERGRID for implementation by Govt. of India under compressed time schedule, which shall be available by November, 2014.
- 23.4 However from the studies carried out it is observed that Raichur – Kurnool 765kV S/c line does not meet the N-1 criteria under outage of this line as the other line is covered under the Krishnapatnam UMPP Transmission System. Therefore, it is proposed that 2nd Raichur – Kurnool 765kV S/c line may be de-linked from Krishnapatnam UMPP transmission system and is proposed to be taken-up as system strengthening scheme for facilitating import of power to SR from other surplus regions.
- 23.5 After deliberations it was agreed that 2nd Raichur – Kurnool 765kV S/c line shall be de-linked from Krishnapatnam UMPP transmission system and shall be taken-up as regional system strengthening scheme.

24.0 Commissioning of 400kV portion of Nellore Pooling Station and LILO of MEPL/SEPL – Nellore 400kV line matching with commissioning of Nellore Pooling Station – Gooty 400kV Quad D/c line

- 24.1 Director (SP&PA), CEA asked POWERGRID to explain the issue in implementation of the Nellore Pooling Station – Gooty 400kV D/c quad line.
- 24.2 DGM (CTU), POWERGRID stated that re-alignment of Transmission System associated with Krishnapatnam UMPP Part-A which included Krishnapatnam – Nellore 400 kV quad D/c line and Krishnapatnam – Gooty 400 kV D/c quad line, was agreed in the 33rd Standing Committee meeting held on 20 October, 2011 at New Delhi wherein following was decided:
- a) Re-alignment of Krishnapatnam UMPP – Gooty 400 kV D/c line as Nellore Pooling Station – Gooty 400 kV D/c quad line and implement the same as regional strengthening scheme.
 - b) Re-alignment of Krishnapatnam UMPP – Nellore 400 kV D/c line as TPCIL - Nellore Pooling Station 400 kV D/c quad line and implement the same as Connectivity System of Thermal Powertech Corporation India Limited.
- 24.3 DGM (CTU), POWERGRID informed that the Nellore Pooling Station – Gooty 400kV quad D/c line is nearing commissioning, however, the Nellore Pooling

Station is being established as part of the 'Common Transmission System associated with ISGS projects in Krishnapatnam area of Andhra Pradesh'. However, in the absence of Nellore Pooling Station, POWERGRID the Gooty - Nellore P.S. 400kV D/c line may not be made available for facilitating power transfer in Southern Grid. Therefore, it was proposed that the 400kV portion of the Nellore Pooling Station and LILO of the MEPL/SEPL – Nellore 400kV line at Nellore P. S. may be commissioned with the Gooty - Nellore Pooling Station 400kV quad D/c line.

24.4 After deliberations the above was agreed by the members.

**List of participants for the 35th meeting of SCPSPSR, held on 04th January, 2013
at POWERGRID office, Gurgaon**

<u>Sl. No.</u>	<u>Name and Organization</u>	<u>Designation</u>
<u>Central Electricity Authority (CEA)</u>		
1.	Ravinder	Member (Power System)
2.	K K Arya	Chief Engineer(I/c)(SP&PA)
3.	Pardeep Jindal	Director (SP&PA)
4.	Anita Galhot	Deputy Director (SP&PA)
5.	Manjari Chaturvedi	Deputy Director (SP&PA)
6.	N R L K Prasad	Deputy Director (SP&PA)
<u>Southern Region Power Committee (SRPC)</u>		
1.	S. R. Bhatt	Member Secretary I/c
<u>Power Grid Corporation of India Ltd (PGCIL)</u>		
1.	Y K Sehgal	COO(CTU)
2.	R K Chauhan	GM(CTU)
3.	Kamal Sarkar	AGM(OS)
4.	Dilip Rozekar	DGM (CTU)
5.	R V Madan Mohan Rao	CDE(CTU)
6.	Anil Kumar Meena	DCDE(CTU)
7.	Amrendra Kishore Singh	Engineer(CTU)
8.	Ankush Patel	ET(CTU)
<u>Power System Operation Corp. Ltd (POSOCO)</u>		
1.	P R Raghuram	ED (SRLDC)
2.	N Nallarasan	DGM (NLDC)
3.	S P Kumar	CM (SRLDC)
4.	G Madhukar	Sr. Engr. (SRLDC)
<u>National Thermal Power Corp. (NTPC)</u>		
1.	Dinkar Devate	GM (Engg-Elect.)
2.	S S Misra	AGM (Engg-Elect)

<u>Sl. No.</u>	<u>Name and Organization</u>	<u>Designation</u>
<u>Neyveli Lignite Corp. (NLC)</u>		
1.	T. Avudaithangam	CGM
<u>Nuclear Power Corp. of India Ltd (NPCIL)</u>		
1.	K P Singh	ACE(Tr.)
<u>Transmission Corp. of Andhra Pradesh Ltd. (APTRANSCO)</u>		
1.	P Srirama Rao	Director/Grid Operation
2.	C V S Subbarao	SE(SP)
3.	V V Ramana Murthy	DE/System Studies
<u>Karnataka Power Transmission Corp. Ltd. (KPTCL)</u>		
1.	S Pratap Kumar	Director(Transmission)
2.	D Chethan	EE (PSS)
3.	A J Hosamani	CEE (PSS)
<u>Kerala State Electricity Board (KSEB)</u>		
1.	M.A.Rawther	Member(Transmission & GO)
2.	G Sreenivasan	Resident Engineer
<u>Tamil Nadu Electricity Board (TNEB)/Tamil Nadu Transco</u>		
1.	S Akshya Kumar	Dir/Tran.Projects(TANTRANSCO)
2.	S Ravichandran	SE/System Studies(TANGEDCO)
2.	R Kumuda	AEE/System Studies(TANGEDCO)
<u>Electricity Department, Puducherry</u>		
1.	K Mathivanan	SE
2.	T Gopalakrishnan	EE

APTRANSCO Studies for Nirmal and SCCL

BY SPEED POST

TRANSMISSION CORPORATION OF ANDHRA PRADESH LIMITED

From: The Chief Engineer (Power Systems),
APTRANSCO,
Vidyut Soudha,
Hyderabad – 500 082

To: The Chief Engineer (SP &PA),
Central Electricity Authority,
Seva Bhavan,
R.K.Puram,
NEW DELHI – 110 066

Lr. No. CE(PS)/SE(SP)/DE(SS)/F.Nirmal/ D.No. 03 /2013 Dt. 7-01-2013

Sir,

Sub: Connectivity of proposed 400kV Nirmal SS in Andhra Pradesh – Reg.

Ref: 1) Lr. No. CE(PS)/SE(SP)/DE(SS)/F.Nirmal/D.No.143/2012 Dt. 30-6-2012
2) 35th Standing committee Meeting held on 04-01-2013 at PGCIL, Gurgaon,
NewDelhi

It was informed by APTRANSCO vide letter cited under ref(1) that Connecting the proposed 400kV Nirmal SS to the upcoming Switchyard of Singareni Collieries(SCCL) Generation project at Jaipur Mandal, Adilabad dt. is found to be more feasible solution from APTRANSCO's perspective.

In continuation of the discussions held during the 35th Standing committee Meeting on the above agenda point, the following are herewith enclosed for necessary action.

- i) Comprehensive 400kV & 200kV scheme details contemplated for the evacuation of Jaipur TPP of Singareni Collieries (2x600MW) as well as for the proposed 400/220kV Nirmal SS.
- ii) Comprehensive Diagram with the 400kV and 220kV interconnectivities for the 400kV Nirmal & 400kV Narsapur SS.
- iii) Study results and remarks.

Encl: As above

Yours faithfully,

Chief Engineer (Power Systems) *7/1/13*

Copy to:

Sri Pradeep Jindal,
Director (SP&PA)
Central Electricity Authority,
Seva Bhavan,
R.K.Puram,
NEW DELHI – 110 066

EVACUATION SCHEME FOR JAIPUR TPP WITH PROPOSED 400 KV NIRMAL SS

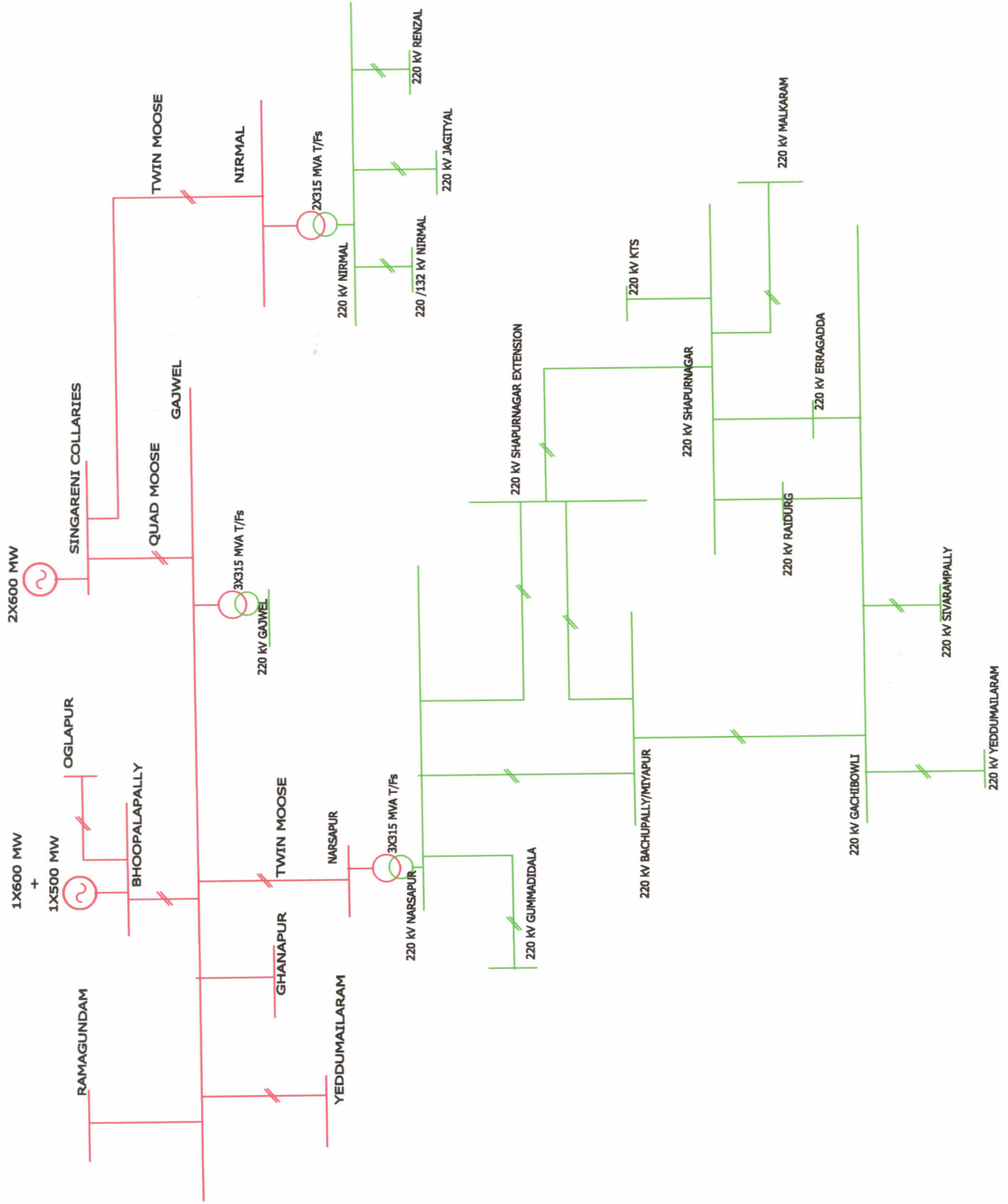

INDEX	400 KV	220 KV	132 KV
	(Red line)	(Green line)	(Blue line)

List of comprehensive works contemplated under Evacuation of Jaipur TPP Generation (Singareni Collieries) (List-A) & for the proposed 400kV Nirmal SS (List-B)

(List-A)

S.No	Description of Substation/Lines	Qty./ Length (kM)
1	Erection of 400/220 kV SS at Narsapur with 3x315 MVA Transformer Capacity.	1No.
2	Erection of 220/132 kV Gummadidala SS with 2x100 MVA Transformer Capacity.	1No.
3	Erection of ShapurNagar Extension SS	1No.
4	Erection of 400kV Quad Moose DC line from 400kV Jaipur TPP to the proposed 400/220kV Gajwel SS	164
5	Erection of 400kV Twin Moose DC line from the proposed 400kV Narsapur SS to 400/220kV Gajwel SS	100
6	Erection of 220 kV Single moose DC line from 400 kV Narsapur SS - 220kV Shapurnagar extension SS .	35
7	Erection of interconnection to 220 kV Shapurnagar extension SS from Shapurnagar existing SS with single moose DC.	0.5
8	Erection of LILO of 2 nd circuit of 220 kV Shapurnagar – Gachibowli DC line at proposed Bachupally/Miyapur SS(XLPE Cable)	3
9	Erection of 220 kV DC line from the proposed 400/220kV Narsapur SS to the the proposed upgraded 220/132kV Gummadidala SS.	25
10	Erection of LILO of 132kV Narsapur – Koudipalli at proposed 220 kV Gummadidala SS.	10
11	Erection of 132 kV DC line from proposed 220 kV Gummadidala SS to the existing 132 kV Gummadidala SS.	10

List - B

1	Erection of 400/220 kV SS at Nirmal with 2x315 MVA Transformer Capacity.	1No.
2	Erection of 220/132 kV SS at Renzal with 2x100 MVA Transformer Capacity	1No.
3	Erection of 400kV Twin Moose DC line from 400kV Jaipur TPP to the proposed 400/220kV Nirmal SS	133
4	Erection of 220 kV DC line from the proposed 400/220kV Nirmal SS to the existing 220kV Jagityal SS.	60
5	Erection of 220 kV DC line from the proposed 400/220kV Nirmal SS to the existing 220kV Nirmal SS.	10
6	Erection of 220 kV DC line from the proposed 400/220kV Nirmal SS to the proposed upgraded 220/132kV Renzal SS.	100

Study Results:

LOAD FLOW STUDY RESULTS FOR ERECTION OF 400/220 kV NIRMAL SS, ADILABAD DISTRICT					
S.No	Name of the Line /Transformer proposed	Load in MW			
		Existing System (Without 400 kV Nirmal)	With 400 kV Nirmal connected to 400 kV Gajwel (Alternative-1)	With 400 kV Nirmal connected to 400 kV SCCL (Alternative-2)	With 400 kV Nirmal connected to 400 kV SCCL & 400 kV Nirmal connected to 400 kV Narsapur (Alternative-3)
1	400 kV RST - Ghanapur	2x246.15	2x269.7	2x278.77	2x272.92
2	400 kV RST - Tallapally	2x219.83	2x233.8	2x239.09	2x235.33
3	400 kV RST - Gajwel	197.67	258.1	281.86	275.07
4	400 kV RST - Dichpally	152.14	110.05	111.39	111.87
5	400 kV RST - Malkaram	228.39	252.2	261.29	253.28
6	400 kV Ghanapur - Tallapally	17.86	6.91	2.87	5.53
7	400 kV Ghanapur - Kurnool	243.5	243.16	243.49	244.17
8	400 kV Ghanapur - Mamidaipally	-29.11	-15.97	-11.06	-16.77
9	400 kV Gajwel - Ghanapur	215.25	172.5	156.24	155.75
10	400 kV Gajwel - Bhoopalapally	2x-251.94	2x-280.6	2x-292.4	2x-289.61
11	400 kV Gajwel - Yeddumailaram	2x316.37	2x296.4	2x289	2x283.61
12	400 kV SCCL - Gajwel	2x540	2x540	2x349	2x273.87
13	400 kV SCCL - 400 kV Nirmal	-	-	2x191	2x266.13
14	400 kV Nirmal - Narsapur	-	-	-	2x99.92
15	400 kV Gajwel - Narsapur	2x271.33	2x263.5	2x260.7	2x188.44
16	400 kV Gajwel - 400 kV Nirmal	-	2x139.17	-	-
17	400 kV Nirmal - 220 kV Nirmal	-	2x77.5	2x104.73	2x91.26
18	400 kV Nirmal - 220 kV Jagityal	-	2x-9.5	2x14.69	2x2.55
19	400 kV Nirmal - 220 kV Renzal	-	2x70.6	2x70.64	2x70.62
20	220 KV RST-220 KV Malayalpally	381.7	342.07	317.73	331.09
21	220 KV RST-220 KV Malayalpally	2x230.75	2x203.8	2x189.52	2x196.77
22	220 kV Malayalapally - 220 kV Durshed	2x78.93	2x91.76	2x97.27	2x94.7

LOAD FLOW STUDY RESULTS FOR ERECTION OF 400/220 kV NIRMAL SS, ADILABAD DISTRICT

S.No	Name of the Line /Transformer proposed	Load in MW			
		Existing System (Without 400 kV Nirmal)	With 400 kV Nirmal connected to 400 kV Gajwel (Alternative-1)	With 400 kV Nirmal connected to 400 kV SCCL (Alternative-2)	With 400 kV Nirmal connected to 400 kV SCCL & 400 kV Nirmal connected to 400 kV Narsapur (Alternative-3)
23	220 kV Malayalapally - 220 kV Bellampally	161.89	161.8	161.83	161.82
24	220 kV Malayalapally - 220 kV Kukkalakuduru	250.02	126.5	84.63	105.28
25	220 kV Kukkalakuduru- 220kV Nirmal	197.53	75.9	34.37	54.84
26	220 kV Malayalapally - 220 kV Jagityal	92.95	112.4	63.08	87.73
27	220 kV Malayalapally - 220 kV Medaram	87.12	57.7	63.37	61.05
28	220 kV Malayalapally - 220 kV Bheemgal	45.27	25.6	29.4	27.82
29	220 kV Malayalapally - 220 kV Pulakurthy	-27.4	-9.8	-2.2	-5.77
30	400/220 kV 1X315 MVA transformers at Ramagundam	282.48	251.16	233.42	242.76
31	400/220 kV 2X250 MVA transformers at Ramagundam	2x280.36	2x249.28	2x231.67	2x240.94
32	400/132 kV 2X200 MVA transformers at Ramagundam	2x194.57	2x172.16	2x163.6	2x167.85
33	400/220 kV 3x315 MVA transformers at Ghanapur	3x184.79	3x186.38	3x186.97	3x185.37
34	400/220 kV 2x315 MVA transformers at Nirmal	-	2x138.64	2x190.06	2x164.42
35	400/220 kV 2x315 MVA transformers at Dichpally	2x197.07	2x151.08	2x146.36	2x148.3
36	400/220 kV 3X315 MVA transformers at Narsapur	3x179.94	3x174.76	3x172.92	3x191.51
37	400/220 kV 3X315 MVA transformers at Gajwel	3x224.79	3x220.43	3x218.92	3x216.01

LOAD FLOW STUDY RESULTS FOR ERECTION OF 400/220 kV NIRMAL SS, ADILABAD DISTRICT

S.No	Name of the Line /Transformer proposed	Load in MW			
		Existing System (Without 400 kV Nirmal)	With 400 kV Nirmal connected to 400 kV Gajwel (Alternative-1)	With 400 kV Nirmal connected to 400 kV SCCL (Alternative-2)	With 400 kV Nirmal connected to 400 kV SCCL & 400 kV Nirmal connected to 400 kV Narsapur (Alternative-3)
38	220/132 kV 2X100 MVA transformers at Renzal	-	2x70.0	2x70.0	2x70.0
39	220/132 kV 3X100 MVA transformers at Nirmal	3x63.35	3x76.68	3x81.12	3x78.91
40	220/132 kV 2X100 MVA transformers at Jagityal	2x46	2x46	2x46	2x46

Voltages

LOAD FLOW STUDY RESULTS FOR ERECTION OF 400/220 kV NIRMAL SS, ADILABAD DISTRICT

Name of the SS	Existing System (Without 400 kV Nirmal)	With 400 kV Nirmal connected to 400 kV Gajwel (Alternative-1)	With 400 kV Nirmal connected to 400 kV SCCL (Alternative-2)	With 400 kV Nirmal connected to 400 kV SCCL & 400 kV Nirmal connected to 400 kV Narsapur (Alternative-3)
400/220 kV Mamidipally	410.17/226.9	409.9/226.7	410.6/227.2	411.2/227.7
400/220 kV Ghanapur	410.1/225.9	409.5/225.6	410.2/226.1	411/226.6
400/220 kV RST	402.7/219.05	401.6/222.2	401.9/222.1	402.6/223.3
400/220 kV Gajwel	410.3/227.5	409.8/227.2	411.1/227.9	412.8/228.7
400/220 kV Narsapur	413.8/230.8	413.4/230.5	414.6/231.1	416.7/232.2
400 kV SCCL	403.1	402.9	404.4	408.5
400/220 kV Nirmal	-	405/220.8	400.1/219.5	411.3/223.9
400/220 kV Dichpally	399.5/216.4	405/223	405.3/223.1	406.4/223.9

LOAD FLOW STUDY RESULTS FOR ERECTION OF 400/220 kV NIRMAL SS, ADILABAD DISTRICT

Name of the SS	Existing System (Without 400 kV Nirmal)	With 400 kV Nirmal connected to 400 kV Gajwel (Alternative-1)	With 400 kV Nirmal connected to 400 kV SCCL (Alternative-2)	With 400 kV Nirmal connected to 400 kV SCCL & 400 kV Nirmal connected to 400 kV Narsapur (Alternative-3)
220/132 kV Dichpally	215.2/133.8	222.6/133.5	222.7/133.6	223.6/134.1
220/132 kV Nirmal	194.2/132.8	220.3/133.5	219/134.5	223.4/133.9
220/132 kV Jagityal	215.16/133	220.6/133.2	219.6/132.5	223.3/133.2
220/132 kV Renzal	-	218.1/134.1	216.6/133.1	221.2/132.8
220/132 kV Durshed	216.9/129.4	219.6/131.2	219.6/131.2	220.7/131.9

EHT Losses:

EHT Losses in MW	Existing System (Without 400 kV Nirmal)	With 400 kV Nirmal connected to 400 kV Gajwel (Alternative-1)	With 400 kV Nirmal connected to 400 kV SCCL (Alternative-2)	With 400 kV Nirmal connected to 400 kV SCCL & 400 kV Nirmal connected to 400 kV Narsapur (Alternative-3)
	530.516	518.553	512.055	512.406

With the proposed 400/220 kV SS at Nirmal the following can be observed.

- In all the three proposed alternatives, the Line loadings, Transformer loadings, Voltages are within the specified limits. 220kV voltages at the existing Nirmal SS are improved and the overloading of the following existing EHT lines and transformers are avoided.
 - i) 220kV RST- 220kV Mallyalapally
 - ii) 220kV Mallyalapally – 220kV Kukkalakuduru (Vemnur)
 - iii) 220kV Kukkalakuduru (Vemnur)– 220kV Nirmal
 - iv) 400/220kV & 220/132kV Transformers at Ramagundam

- In the above three alternatives, EHT losses are reduced more from 530.516 MW to 512.055 MW when the proposed 400/220kV Nirmal SS is connected to the 400kV SCCL (Alternative-2) when compared to the other two alternatives. With this proposal, around 380 MW of Singareni Collieries generation can be directly utilized by 400kV Nirmal SS. As such, the loadings on the 400kV SCCL-Gajwel lines are reduced to that extent. Even in N-1 contingency of Gajwel-SCCL DC line, the power can be evacuated from SCCL generation more comfortably with the remaining lines.
- In view of the above, connecting the proposed 400kV Nirmal SS directly to the 400kV SCCL (Singareni Collieries) is found to be the better feasible solution .

System Studies for Mangalore-Kasargode-Kozikode Link

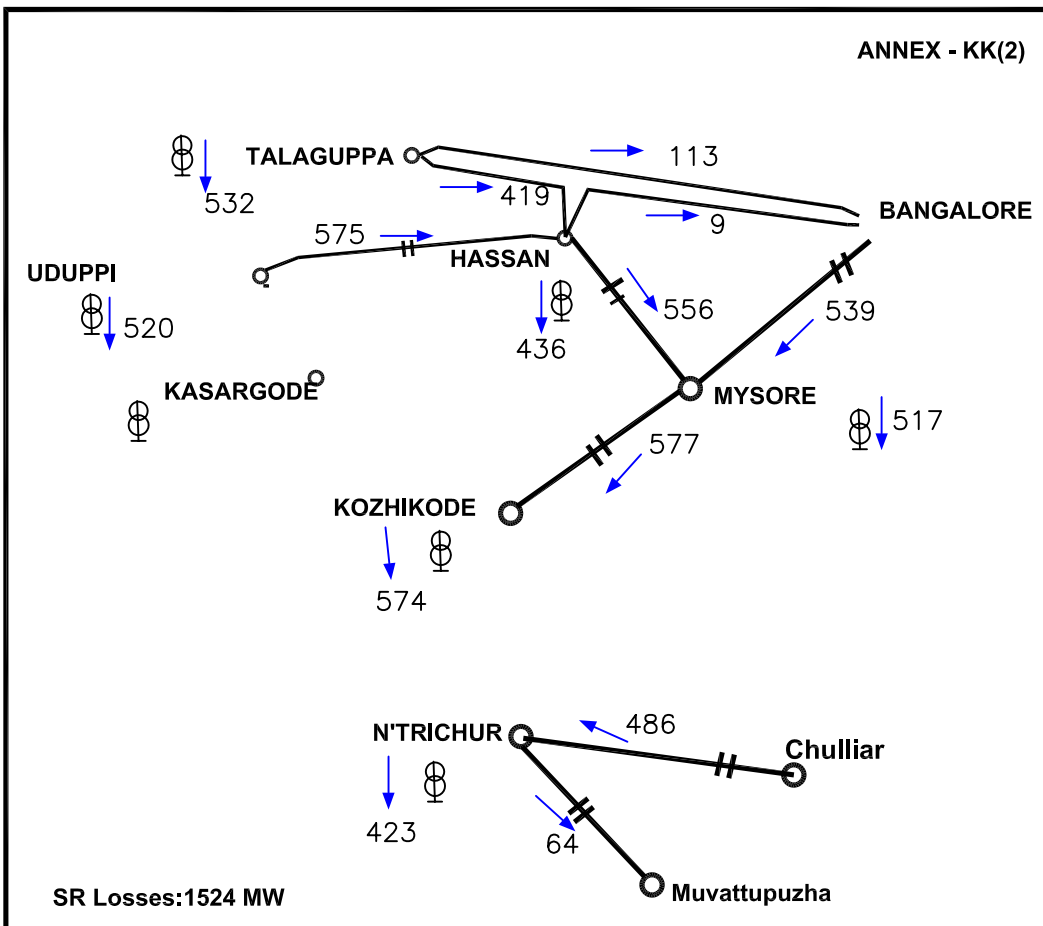
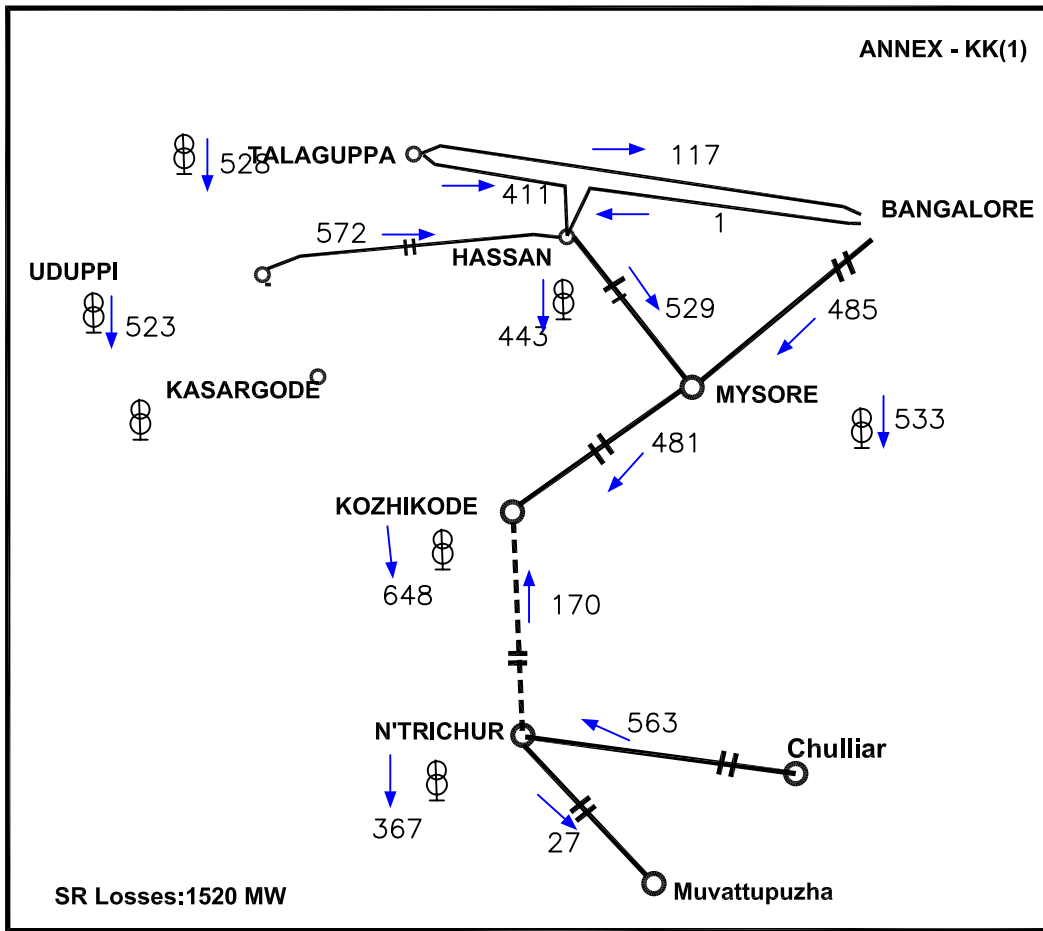

ANNEX - KK(3)

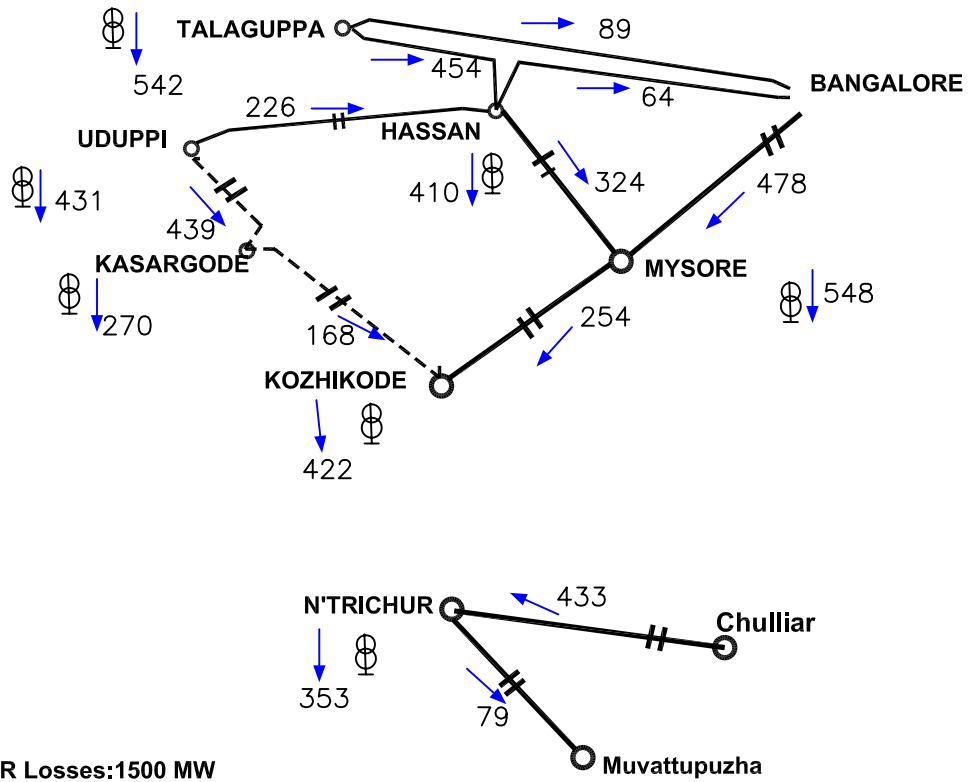

SR Losses:1500 MW

ANNEX - KK(4)

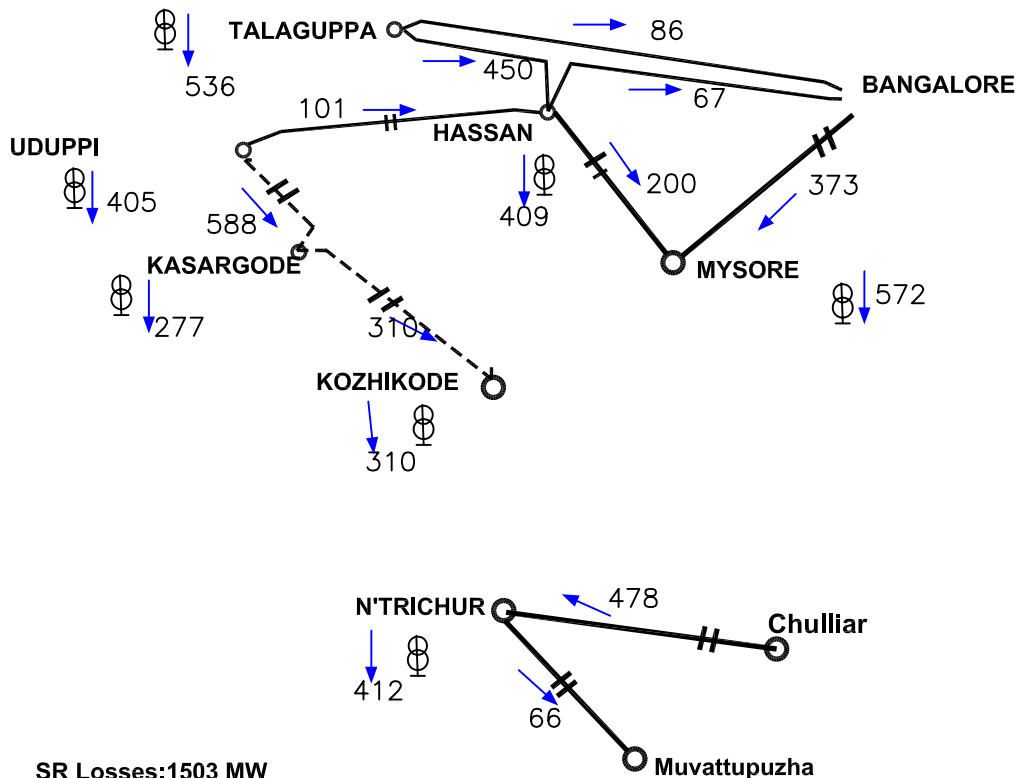

SR Losses:1503 MW

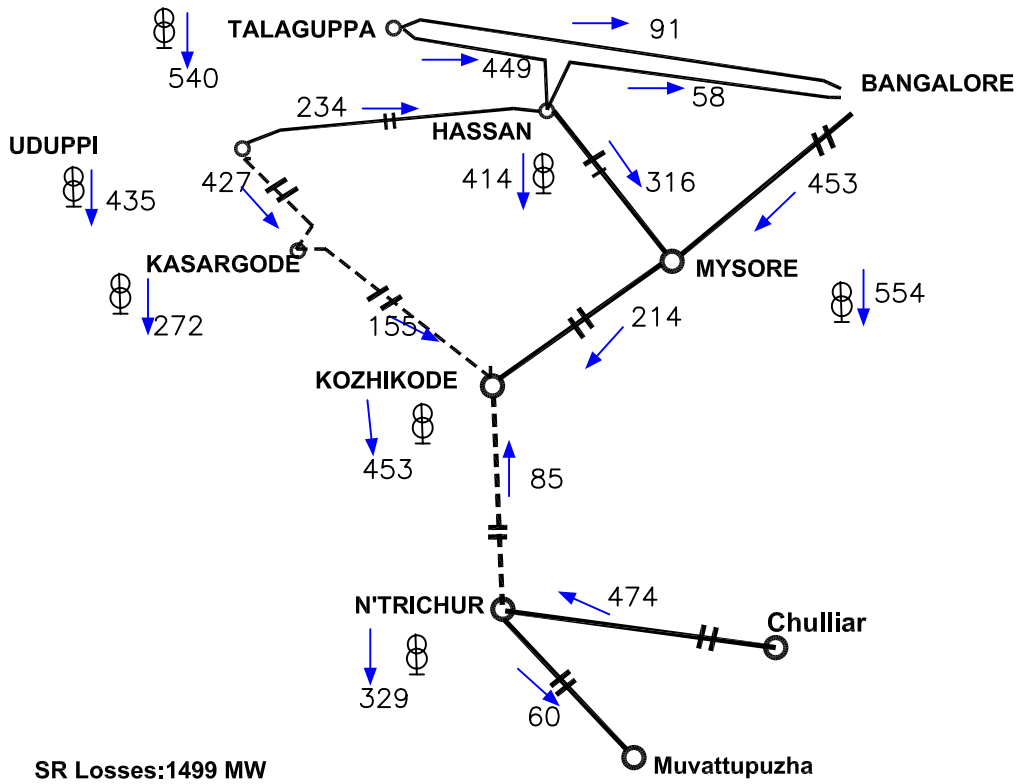

Load and Generation data format for STUs

State:

LOAD

	2015-16	2018-19	
Summer Peak			
Summer Off- Peak			
Winter Peak			
Winter off- Peak			
Monsoon Peak			
Monsoon Off-Peak			
18th EPS Load			

GENERATION

		2015-16		2018-19	
		Installed Cap.	Dispatch	Installed Cap.	Dispatch
Summer Peak	Thermal				
	Hydro				
	Wind				
	Solar				
Summer Off- Peak	Thermal				
	Hydro				
	Wind				
	Solar				
Winter Peak	Thermal				
	Hydro				
	Wind				
	Solar				
Winter off- Peak	Thermal				
	Hydro				
	Wind				
	Solar				
Monsoon Peak	Thermal				
	Hydro				
	Wind				
	Solar				
Monsoon Off-Peak	Thermal				
	Hydro				
	Wind				
	Solar				

Maximum Import/Export requirement of State considering various contingencies:

	2015-16	2018-19	
Summer Peak			
Summer Off- Peak			
Winter Peak			
Winter off- Peak			
Monsoon Peak			
Monsoon Off-Peak			